

User and installation manual for **Auto-Fill BWT**



Installation

The BWT Laava heater is specifically designed for the BWT function. It comes with pre-installed water tanks and is factory plumbed for Auto-fill function..

Please be sure to also look up the installation and safety distances in the user and installation manual for the Laava heater. The BWT steam generator units work passively, meaning they do not have their own power supply; the water in the tanks is heated by means of radiation from the heater elements.

The external water equalizing tank is for maintaining the water surface level inside the BWT tanks.

The equalizing tank and the two BWT tanks are connected to each other and form a set of communicating vessels. The equalizing tank, must be installed at the right height to ensure that the water surface levels of the BWT steam generator tanks are at the optimal level at all times. The equalizing tank can be mounted inside the sauna next to the Laava heater, under the bench or in an adjacent utility closet. If mounting inside the sauna, the tank will become very hot and should be protected to prevent users from accidental touching.

The float inside the tank can be adjusted, which changes the amount of water in the tanks.

Note! Do not install the equalizing tank or adjust the float so that water could overflow from the BWT tanks; the water surface level must be 20 mm (about ¾") below the brim of the BWT tanks. The reference line on the equalizing tank must be at the same height of the heater, and if this is not possible, adjust the float in the equalizing tank accordingly. For more information, please refer to the images on the next page. Adjust water level in equalizing tank to prevent water from escaping out of the two open holes on the back of the equalizing tank.

A 3/8" shut-off valve must be installed ahead of the equalizing tank fill valve as this ensures that the system can be shut down for maintenance and flushing. This stopcock (shut-off valve) must always be open when the sauna is in use.

Drain valve. If there is no floor drain under the drain cock (valve), we recommend installing a heat-resistant (silicone) hose or copper pipe from the drain cock to the floor drain. To make flushing the tanks easier, the drain cock can be moved to the end of the hose or pipe near the floor drain.

User and installation manual Auto-Fill BWT Laava

Installation of the equalizing tank (ET) for the Laava heater

The equalizing tank has a **reference line** that is to be installed at the **same level** with the top of the heater. "S" = 12" minimum.

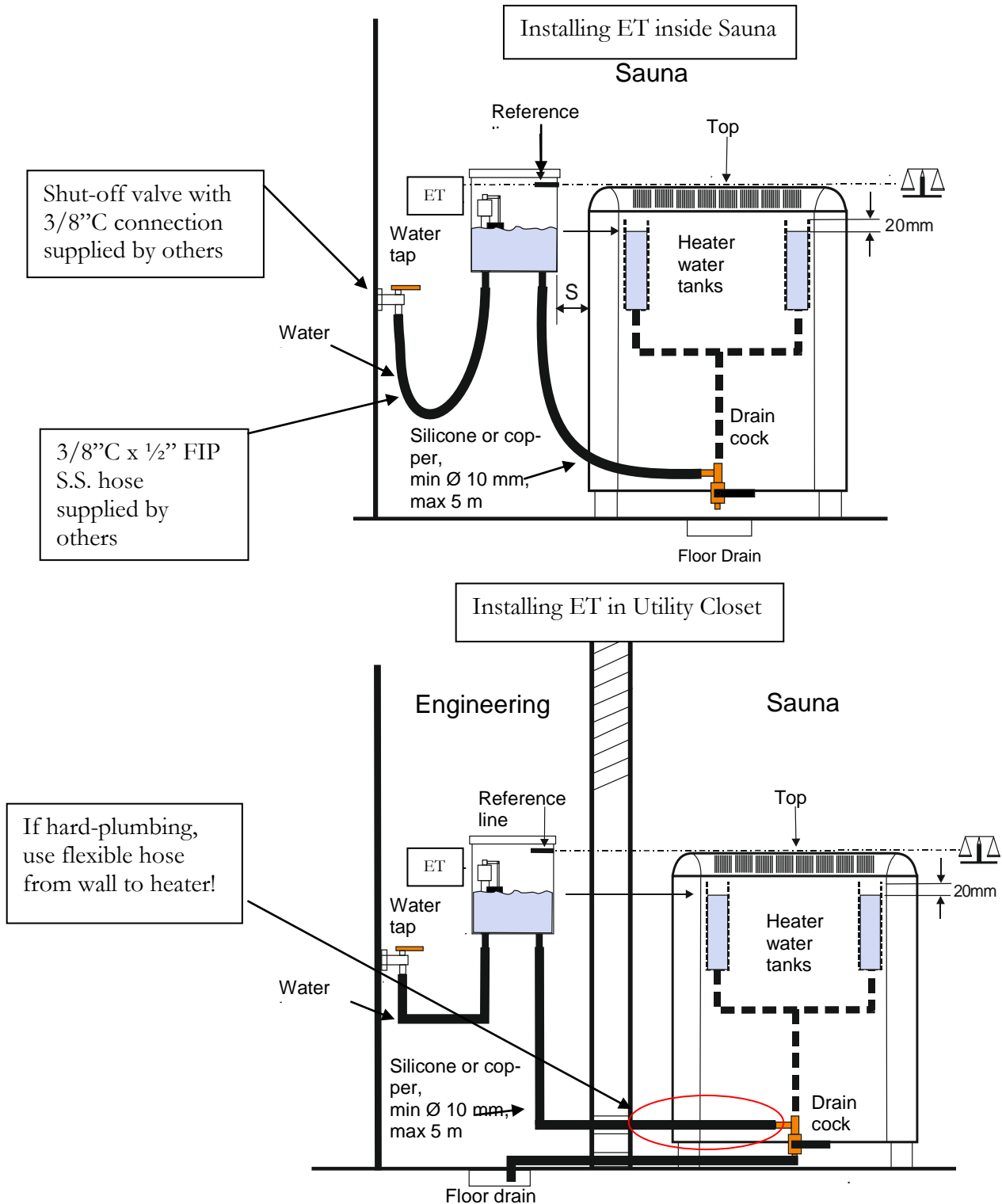

User and installation manual **Auto-Fill BWT Laava**

Maintenance of the BWT water tanks

There is a drain cock below the front of the heater. This drain cock must be connected to a floor drain to avoid releasing hot water onto the sauna room floor when flushing the system. When the heater is in use, the drain cock must be closed. We recommend flushing the system after each day of use. This flushes away pieces of limescale and prevents them from accumulating on the bottom of the tank. Check the drain hoses periodically for limescale blockages to ensure the tanks drain properly.

Decalcification.

Unless the property is fitted with a water softener, hard water will cause lime scale to collect on the sides and bottom of the tanks relatively quickly.

In a commercial sauna, decalcification must be done every one to four weeks. If the sides of the tank are covered in an opaque (0.5 mm / .020" or thicker) layer of lime scale, the tanks must be decalcified.

Decalcification is always done when necessary, and the frequency depends on how often the sauna is used and how hard the water is. The easiest way to check the tanks for lime scale is to lift off the lids once every week to see if there is lime scale build-up on the sides and bottom of the tank.

We recommend using food grade citric acid for decalcification of the tanks. (Available From TyloHelo or your sauna dealer)

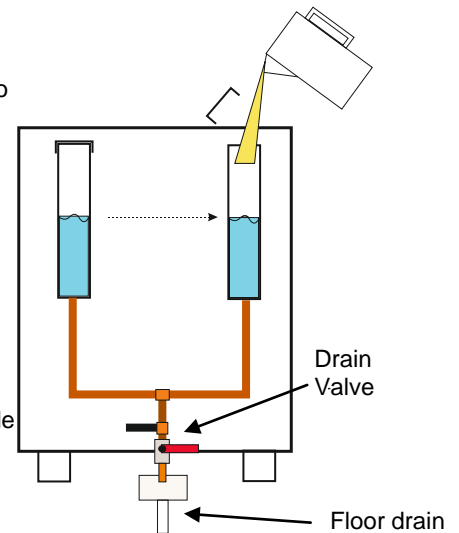

Decalcification using citric acid:

- Mix about 50 grams or 1.7 ounces of citric acid in 0.5 litres (1/2 quart) of warm water per tank and pour the mixture into each BWT tank filled with warm water from a recent sauna session.
- Leave for 60 minutes, then flush and rinse tanks a couple of times after this.
- Pick or vacuum pieces of limescale out of the tanks.

Basic maintenance tasks:

It is good to do these tasks every day when cleaning the sauna room.

NOTE: Water coming out of the drain cock may be scalding hot.

- Leave the stop cock / shut-off valve of incoming water open.
- Open the drain cock / shut-off valve and leave it open for 10–15 minutes. This will allow you to rinse each tank effectively.
- Close the drain cock / valve.
- The system will fill up the tanks on its own and it will be ready for use in a moment.
- The stop cock of incoming water can be closed when the sauna is not being used..

Daily tasks:

Open the stop cock / shut-off valve of incoming water (if it was closed overnight).

Weekly tasks:

Look into the tanks to check them for lime scale deposits. If necessary, plan when to decalcify the tanks or carry out other tasks.

Once a month:

Look into the space reserved for the stones to make sure there are enough stones to cover the heating elements. If you notice any broken stones, pick out the pieces and replace the broken ones with new stones.
As the heater is warming up, check the heating elements to see if they all are red. If not, contact the maintenance department.

This space left blank

Spare parts for Laava BWT

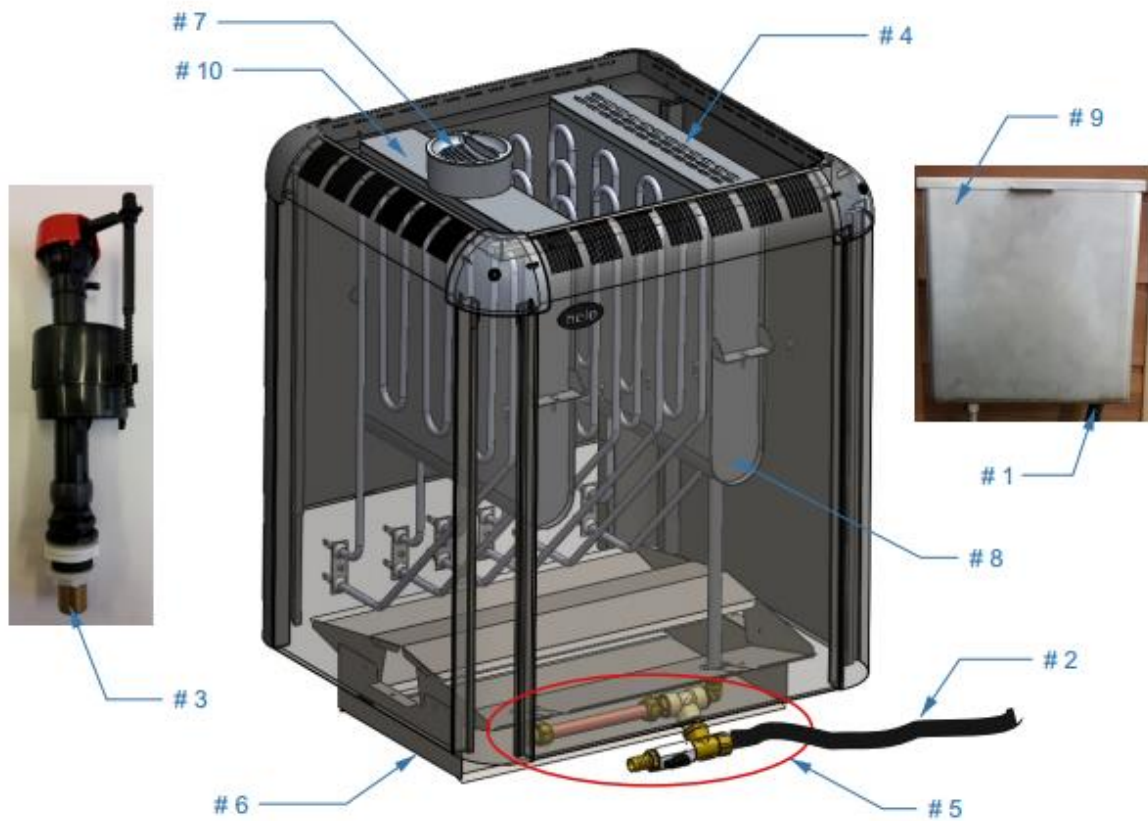

Figure #	Part Number	Part Description
1	2025-01	Nipple, 1/2" hose barb x 1/2" FIP, brass
2	5050-114	Hose, Silicone, Black, 5M (16.4')
3	2123-110	Valve, Float, Water Level Regulator
4	2137-72	Cover, BWT Tank w/ grill holes
5	2123-111	Valve, Water Manifold Assy. Complete kit
6	8003-31	Plate, Laava, Bottom Heat Deflector
7	8221-01	Holder, BWT Fragrance cup, Black
8	8100-469	Tank, BWT, Internal to Heater
9	8100-468	Tank, BWT equalizing reservoir (complete kit)
10	2137-20	Cover, BWT tank w/ Fragrance holder (pn# 7)
N/A	1301-20	Clamp, Hose Worm Drive, SAE 08,15-24mm, S20

Place Serial Number Label Here

For installation, parts or service related questions, please contact TyloHelo Technical support at 1-877-780-4427 or via email at techsupport@tyloheloinc.com

**TyloHelo Inc. 1 Year Limited Warranty for BWT Auto-Fill
Equipment**

TyloHelo Inc. (dba: Saunatec) warrants the BWT Auto-Fill Equipment to be free of manufacturing defects both as to workmanship and material and will replace or repair defective parts for the period of time and in accordance with the conditions set forth below.

Application: This warranty applies when the warranted product (a) is installed in accordance with the installation instructions provided, (b) is properly and reasonably maintained, and (c) has not been subject to damage, misuse or abuse.

Duration of Warranty: TyloHelo Inc. or its authorized representative will provide parts to replace those with manufacturing or workmanship defects for a period of one (1) year from the original date of installation.

Labor Reimbursement: In-field labor is not covered for replacement or repair of TyloHelo Inc. BWT Auto-Fill Equipment.

Return Goods Authorization (RGA): An RGA number, assigned by TyloHelo Inc. Technical Support Representative must accompany all returned parts. Parts which are returned without an RGA may be refused or may not be replaced or repaired.

Claim Procedure: Request for repair or replacement, an RGA number or other warranty information shall be directed to TyloHelo Inc. by calling toll-free 1-877-780-4427 or via e-mail at techsupport@tyloheloinc.com or written mail at TyloHelo Inc., 575 East Cokato Street, Cokato, MN 55321. Defective parts returned for repair or replacement must be shipped prepaid to TyloHelo Inc. at the above address. Shipping costs for return of replacement product(s) to the purchaser will be at the expense of the purchaser unless otherwise arranged by TyloHelo Inc. Technical Support Staff.

Limitations, Exclusions and Remedies: There are no warranties which extend beyond the descriptions of the face hereof. This limited warranty is in lieu of all warranties, expressed or implied and all other obligations or liabilities on the part of TyloHelo Inc. There shall be no implied warranty of merchantability. TyloHelo Inc. neither assumes nor authorizes any person to assume for it any other obligation or liability in connection with the sale of its products.

Damages for breach of this warranty shall not exceed the lesser of the cost of repair or replacement. Repair or replacement shall be the exclusive remedy available to the purchaser.

Under no circumstances shall TyloHelo Inc. be liable by virtue of this warranty or otherwise for any special, indirect, secondary, incidental or consequential damage of any nature to any person or property arising directly or indirectly out of the use or inability to use a warranted product.

Some states do not allow limitations on how long an implied warranty lasts, or the exclusion or limitation of incidental or consequential damages, so the above limitations and exclusions may not apply to you.

Disputes: Any lawsuit alleging breach of this limited warranty shall be commenced within one year from the date of breach.

This warranty gives you specific legal rights, and you may have other rights which vary from state to state.