

YOU WILL NEED:

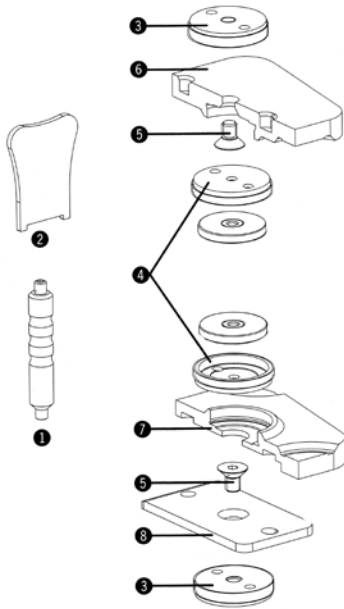

- | | |
|--------------------------------|--|
| 1. Magnet Removal Tool | 8. Adhesive Plate (note beveled edge) |
| 2. Assembly Tool | Also Needed: |
| 3. Mounting Plate | • Petroleum Jelly |
| 4. Magnet Pot | • Loctite 330 [®] adhesive with activator |
| 5. Mounting Screws | • +10mm Spacer Plate* |
| 6. Base Plate – Maxilla | |
| 7. Adjustment Plate – Mandible | |

HOW TO:

1. Set the articulator to average-value settings (standard working conditions).

* 30-35° condylar inclination * 10-15° Bennett angle * Anterior guidance pin at 0

2. Apply a thin layer of petroleum jelly on areas that may come in contact with glue, other than the adhesive plate (8). This will assist in removing the glue without damaging the carbon surface if readjustments are necessary.

3. Remove the blue model plates from the articulator.

4. Remove the magnets with the magnet removal tool. (1)

5. Unscrew the magnet pots, using the assembly tool (2), and remove them.

6. In place of the magnet pots, screw in the mounting plate (3) up to the stop, using the assembly tool.

7. Unscrew the magnet pot (4) out of the maxillary base plate (6) (TOP)

8. Affix the maxillary plate with the mounting screw (5) at the mounting plate (3) in the upper arm of the articulator.

9. Screw in the magnet pot (4) into the maxillary plate.

10. Use the magnet removal tool to insert magnets in the upper and lower plate. Make sure the magnets do not “click” into place because a hard blow may damage them.

* **NOTE:** If calibrating with a “Classic Artex” 110 mm key, attach a “Spacer Plate, +10 mm”, (46011, not pictured) to the upper Splitex Plate now (magnet to magnet).

11. Make sure the thin layer of petroleum jelly was applied to the lower part of the articulator, and then insert the adhesive plate (8) into the lower articulator arm, **with the beveled edge at the rear.** (This will ensure that you have easy access to remove the calibration plate when necessary). Use the mounting screw (5) to affix the adhesive plate to the mounting plate in the lower arm.

12. Turn the articulator upside down and place the carbon-series Splitex key (C6010)

onto the upper plate, magnet to magnet.

13. Put the lower plate (7) with magnet onto the bottom of the calibration key.

Instructions for application of Loctite[®] 330:

1. Clean the adhesive plate and bottom (milling holes) of the mandibular plate to be sure it is free of grease.

2. Use Loctite adhesive to glue the mandibular plate to the adhesive plate. Spray activator onto the bottom Splitex plate for the mandible. Apply two parallel lines of adhesive centered between the edges and the center milling holes of the adhesive plate. Immediately close the articulator and slightly press on the anterior pin for 5 seconds until the adhesive has completely adapted on both sides. Let set for 10 minutes. The calibration procedure is finished when the adhesive has completely set.

Mounting Unit Exception: The one-piece lower Splitex plate for the Mounting Unit (C6020) is designed to attach solely by gluing, not with a screw.

Important Notes: For cleaning and care of Splitex plates, use only cleaning agents that are suitable for light metals, following the manufacturer’s instructions. Do not clean Splitex plates in an ultrasonic bath, as the anodized coating may be damaged. Do not use cleaning agents with a pH of <5 or >8 since these might damage the anodized surfaces.

Since heat will irreversibly reduce the power of the magnets, do not steam-clean or boil the magnets.



40031 SPLITEX PLATES
CARBON TECH GUIDE
REV. 0