

## OPERATING INSTRUCTIONS

### MODEL DS61 or DS62 DOUBLE SHEET CONTROLLER

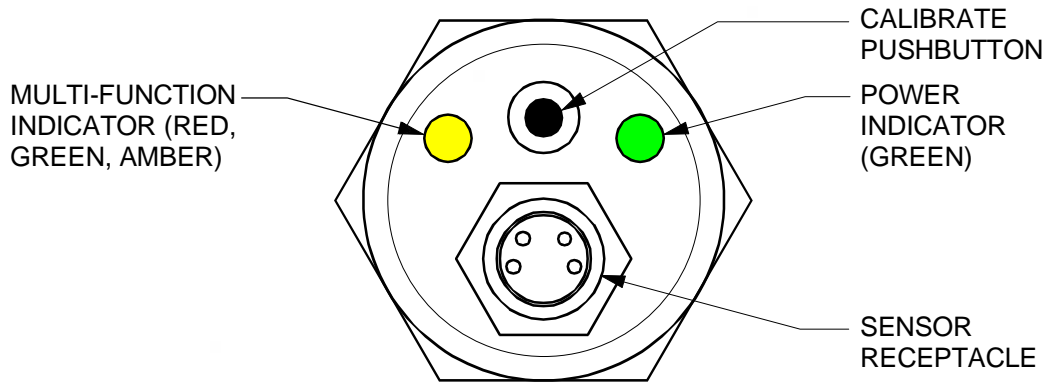

The Prime Controls Model DS61 and DS62 Double Sheet Controllers comprise a microcontroller based control module in an 18 mm threaded aluminum housing that can be connected to a family of permanent magnet sensors through an 8 mm receptacle at the face end of the controller. A four-pin 12 mm connector at the rear end provides connections for power, ground, single output and no-double output. The model DS61 provides sourcing outputs while the DS62 provides sinking outputs, otherwise the two units are functionally identical. Status and setup controls on the face include a green power indicator, a multi-color multi-function indicator and a pushbutton switch.

The DS61/DS62 requires a dc power source in the voltage range of 12 to 24 volts at 40 mA + load current for the DS61. When power is applied, the green indicator is solidly ON.

When first powered up, the DS61/DS62 controller displays the firmware version number by flashing the multicolor indicator, first red then green (See FIRMWARE VERSION later in this document). The controller then checks for a valid probe. If a fault is detected, the multicolor indicator flashes red indefinitely at a 10 Hz rate. If no fault is detected the controller goes into normal sensing operation.

During normal sensing operation, the multi-color indicator tracks the state of the outputs indicating no metal (OFF), single thickness (green) and double thickness (red). When the indicator is OFF, the single output is OFF and the no-double output is ON. When the indicator is green, the single output is ON and the no-double output is ON. When the indicator is red, the single output is OFF and the no-double output is OFF. The output logic is designed for fail-safe operation. If the controller loses power or an output line is broken, the unit reports a double by default.

September 27, 2006

In meter mode, the multicolor indicator flashes at a rate proportional to the strength of the signal from the attached sensor. For thin metals or no metal the indicator flashes slowly, for thick metals the indicator flashes rapidly. If meter mode is invoked after calibration, when the controller is sensing no metal the indicator flashes amber, when the controller senses an acceptable thickness (single), the indicator flashes green and when it senses higher than acceptable thickness (double), the indicator flashes red.

During calibration, the multi-color indicator flashes amber at various rates to indicate the status of the process as described later in this document.

The small calibrate pushbutton mounts flush with the face of the unit to insure no inadvertent activations that can cause loss of calibration.

## PROBES

The DS61 and DS62 operate with several different Prime magnetic probes including Models PM4, PM10, and PM15. All probes are potted and completely sealed. The probes do not respond to small amounts of fine metal filings, oil or dirt.

Probe Model	Min thickness	Max thickness	Probe Diameter
PM4	.04 mm (.0015")	.40 mm (.015")	18 mm (0.70")
PM10	.10 mm (.004")	1.0 mm (.040")	30 mm (1.18")
PM15	.15 mm (.006")	1.5 mm (.060")	36 mm (1.42")

## INSTALLATION

Installation of the individual components of the DS61/DS62 system is covered in the following paragraphs:

### DS61/DS62 Control Module

The control module is designed to mount with a simple bracket, where convenient, between the probe and a higher level controller such as a PLC. Avoid mounting locations with excessive heat and vibration. See the housing dimensional drawing later in this document.

### Probes

The probe must be mounted so that the sheet is in contact with the probe face as it passes. The face of the probe is made of hard magnetic material and will last through many years of operation.

The Models DS61 and DS62 Double Sheet Detectors can operate with no contact between the sheet material and the probe if the gap is kept very small and is held constant. A constant gap is very important since a small change in gap causes significant change in the sensor signal. If the system is to be operated with a gap between the probe and the sheet material, the unit must be calibrated after the gap is established. If the gap is too large, the unit will not calibrate.

## Electrical Wiring

The connection between the probe and the controller requires a Prime Controls adapter cable model CBL110-X, where X indicates length.

Power to the controller and the outputs from the controller connect through an industry standard male, four-pin 12mm connector. For this connection use Prime Controls cable CBL104-3.

The pin-out is as follows:

Pin 1 -	Power	Brown wire on standard cable
Pin 2 -	Single Output	White wire on standard cable
Pin 3 -	Common	Blue wire on standard cable
Pin 4 -	No-double Output	Black wire on standard cable

## METER MODE

The DS61/DS62 Controller provides a feature for monitoring the sensitivity to the metal thickness. To invoke “meter” mode, press and hold the pushbutton switch for three or more seconds. When the switch is released, the multi-color indicator begins flashing at a rate proportional to the strength of the sensor signal. For minimum or no signal, the flash rate is approximately 1 Hz. For maximum signal, the flash rate is approximately 25 Hz. If the controller senses no metal at the probe face the indicator flashes amber. If the controller senses metal in the range of a calibrated single, the indicator flashes green. If the metal thickness is greater than the acceptable single thickness, the indicator flashes red.

Press and release the pushbutton once to exit meter mode. The multi-color indicator reverts to following the outputs.

The gauging function of the controller remains active during meter mode. As the sensor signal moves above and below the calibration threshold, the outputs switch accordingly, and the indicator changes color as described above.

## MULTI-COLOR INDICATOR INTERPRETATION

The multi-color indicator provides information about the state of the controller. During normal gauging, the state of the indicator follows the outputs as shown in the chart below:

Metal at Probe Face	Single Output	No-Double Output	LED
No Metal	OFF	ON	OFF
Single Thickness	ON	ON	Green
Double Thickness	OFF	OFF	Red

In meter mode, the yellow indicator flashes at a rate proportional to the strength of the signal from the attached sensor. For minimum or no signal, the flash rate is approximately 1 Hz. For maximum signal, the flash rate is approximately 25 Hz. . If the controller senses no metal at the probe face the indicator flashes amber very slowly. If the controller senses metal in the range of a calibrated single, the indicator flashes green more rapidly. If the metal thickness is greater than the acceptable single thickness, the indicator flashes red very rapidly.

When power is first applied to the DS61/DS62, the indicator flashes a code that reveals the version number of the firmware controlling the unit. See the section below on **FIRMWARE VERSION**. Also, after power-up, the controller assesses the characteristics of the attached probe. If the probe is connected and functioning properly, the indicator begins displaying the current gauge state, which at power-up should be OFF. There must be no metal against the face of the probe at power up because the controller records the probe output as the reference for determining no metal present.

If no probe is connected or there is an open in the cable to the probe at power-up, the controller first flashes the firmware version code and then flashes red indefinitely at a 10 Hz rate.

During calibration, the indicator, when ON, is always amber in color.

During single-sample calibration, if there is no metal against the face of the probe when the calibration pushbutton is pressed, the indicator flashes amber at a 2.5 Hz rate until metal is placed against the probe face. Once metal is placed against the probe face, the indicator turns off momentarily, and then if calibration is successful, the indicator flashes 4 times in succession at a 5 Hz rate then reverts to following the state of the outputs. If calibration is not successful (the sensor signal is too weak), the indicator flashes amber at a 10 Hz rate for 15 seconds or until the pushbutton is pressed again. If 15 seconds elapse with no repress, the indicator reverts to tracking the outputs and the previous calibration values are re-installed.

When two-sample calibration is invoked, the indicator begins flashing amber at a 2.5 Hz rate until the pushbutton is pressed for recording of the second calibration thickness. If 25 seconds elapse before the press of the calibration pushbutton, the controller aborts calibration and re-installs the previous calibration values. If the pushbutton is pressed within the 25 second period to record the second thickness, the indicator flashes amber four times in succession at a 5 Hz rate then reverts to following the state of the outputs. If the thickness of the two samples is too close for reliable gauging, the indicator flashes amber at a 10 Hz rate for up to 15 seconds or until the pushbutton is pressed again.

The DS61/DS62 controller constantly monitors the current draw of the attached probe. If the measured current goes out of specification for whatever reason, the multi-color indicator flashes red at a 10 Hz rate until the problem is corrected or the power is turned off.

## **PUSHBUTTON OPERATION**

The calibration pushbutton allows control of the operational mode of the DS61/DS62 controller as follows:

1. From gauge mode, pressing and releasing once within 3 seconds, initiates calibration on a single thickness of metal.
2. From error mode, pressing the pushbutton once retries calibration.
3. From gauge mode, pressing the pushbutton twice within 0.7 seconds, initiates two-sample calibration mode and records the first point. A third tap records the second calibration point, installs the new calibration and exits calibration mode.
4. From gauge mode, pressing and holding the pushbutton for at least three seconds, initiates meter mode.
5. From meter mode, pressing the pushbutton once exits meter mode.

## **CALIBRATION**

The DS61/DS62 Controller offers two modes of calibration or “teach”, a one-sample mode and a two-sample mode. Both are invoked through the pushbutton on the face of the unit.

The one-sample mode simply sets the gauge threshold at 125% of the signal present at the time the pushbutton switch is pressed. The two-sample mode sets the gauge threshold halfway between the readings from the two-sample calibrations.

The latest calibration information is always stored in non-volatile memory and is restored at power-up.

## **One-sample Calibration**

One-sample calibration may be initiated with metal already against the probe face or prior to metal coming in contact with the probe face. If calibration is initiated with no metal against the probe, the controller flashes the amber indicator at a 2.5 Hz rate until metal is brought in contact with the probe. The controller delays for half second from the time it first detects metal until the calibration data is collected to allow full contact of the metal with the probe face.

1. Place a single thickness of the metal to be sensed against the face of the probe.
2. Press the calibration pushbutton.

Alternatively,

1. Press the calibration pushbutton.
2. Place a single thickness of the metal to be sensed against the face of the probe.

If the calibration is successful, the indicator flashes amber 4 times at a 5 Hz rate and then reverts to following the outputs. If calibration is successful, the new calibration value is stored in non-volatile memory.

If the sensor signal is too weak or too strong, the calibration will fail. The controller indicates the failure by flashing amber at a 10 Hz rate for 15 seconds or until the pushbutton is pressed again. If the pushbutton is not pressed within 15 seconds, the controller aborts calibration and re-installs the previous calibration parameters.

## **Two-sample calibration**

Two-sample calibration may be used to more closely control the gauge thresholds. Two-sample calibration places the gauge threshold at the midpoint between the two recorded samples. Whereas the single-sample calibration always discriminates on a 25% change in signal relative to the sample point, the separation of sample points in the two-sample mode may be varied according to the user's needs.

When calibrating in two-sample mode, the order of sampling the thicker and thinner material makes no difference. The controller sorts out the order and sets the threshold the same either way. The calibration procedure is as follows:

1. Place the first material sample against the probe face.
2. Tap the pushbutton twice in succession within 0.7 seconds. The first sample is taken and the indicator flashes amber at a 2.5 Hz rate for up to 25 seconds.
3. Within 25 seconds, place the second material sample against the probe face.
4. Tap the pushbutton once. The second sample is taken, the new threshold installed, and the indicator flashes amber four times at a 5 Hz rate and then reverts to following the outputs.

After calibration, the LED and outputs respond as shown in the chart below:

<u>Metal at Probe Face</u>	<u>Single Output</u>	<u>No-Double Output</u>	<u>LED</u>
No Metal	OFF	ON	OFF
Single Thickness	ON	ON	Green
Double Thickness	OFF	OFF	Red

Note that the single output alone is sufficient to fully check for a valid single thickness of metal since it is OFF for both a no-metal condition and a double condition. The no-double output allows discrimination between no-metal and double faults.

## **TROUBLESHOOTING**

When power is applied (12 to 24 volts dc), the green LED should be ON solidly. If the green LED remains off with power applied, check the cable connections and the integrity of the cable.

It is important to remember that when powering up the DS61/DS62, there should be no metal against the probe face. The controller reads the probe signal at power-up to determine the minimum signal level of the probe.

The flash pattern and color of the multi-color LED on the DS61/DS62 can be helpful in the diagnosis of problems with your installation. Check the following:

### **Immediately After Power-up**

1. The multicolor LED flashes red then green at a 2.5 Hz rate to indicate firmware version number and then turns OFF. This is normal startup.
2. The LED flashes green then red at a 2.5 Hz rate to indicate firmware version number and then begins flashing red rapidly (10 Hz). This can indicate a) there is metal against the probe face, b) the probe is disconnected, or c) the cable to the probe has an open, or d) the probe is faulty.

### **During Single-Hit Calibration**

1. The LED constantly flashes amber at a 2.5 Hz rate. This is normal if no metal is against the probe face. Persistence of this pattern with metal against the probe face can indicate a) the metal is non-ferrous, b) the metal is too thin for the probe, or c) the probe is faulty.
2. The LED flashes amber at a rapid (10 Hz) rate. This can indicate that a) the metal is too thin to be gauged by the probe in use or b) the probe is faulty.

## During Two-Hit Calibration

1. After the pushbutton switch is pressed twice in less than 1 second, the LED flashes amber at a 2.5 Hz rate. This is normal; the controller is waiting for the second thickness of metal to be placed against the probe and the pushbutton to be pressed once again.
2. After the third press of the pushbutton (to record the second thickness), the LED flashes amber at a rapid (10 Hz) rate. This indicates the two samples were so close in thickness that the difference cannot be reliably discriminated.

## While Gauging

1. The LED flashes red rapidly (10 Hz). The probe is either faulty or disconnected. Check the cabling and probe.
2. The LED indicates the expected state of the outputs as follows:

LED State	Single Output (pin2)		No-Double Output (pin4)	
OFF	OFF	DS61 – low DS62 – high	ON	DS61 high DS62 low
GREEN	ON	DS61 – high DS62 – low	ON	DS61 – high DS62 – low
RED	OFF	DS61 – low DS62 – high	OFF	DS61 – low DS62 – high

## FIRMWARE VERSION

The format of the firmware version number is of the form 1.2, comprising a single digit integer part and a single digit fractional part. When first powered up, the controller displays the version number by flashing the integer digit value in red and the fractional digit value in green. To determine the version number, immediately after power-up, count the number of red flashes and then the number of green flashes. For example, a single flash of red followed by a single flash of green indicates a version number of 1.1.



## SPECIFICATIONS

### Power

Type:	DC
V+ Connection:	12 mm Connector, Pin 1
Common	12 mm Connector, Pin 3
Voltage:	10 to 24 volts
DS61 Max Current:	40 milliamps + output loads
DS62 Max Current:	40 milliamps
Protection:	Reverse polarity protected. Transient Voltage Suppress @ 30 Volts

### Logic Output Electrical Specifications

#### DS61 Sourcing Outputs

Connection:	12 mm Connector, Pin 4
Max. source current:	50 mA, fuse limited
Output Voltage High:	Supply Voltage less 1 volt
Over-current protection:	Self-resetting thermal fuse
ESD protection:	Transient Voltage Suppressor @ 30 Volts

#### DS62 Sinking Outputs

Open Drain	
Connection:	12 mm Connector, Pin 2
Max. applied voltage:	30 Volts, TVS limited
Max. current, momentary:	40 Amps
Max. current, sustained:	50 mA, fuse limited
Max. off state leakage @ 30 V:	25 uA
Over-current protection:	Self-resetting thermal fuse.
ESD protection:	Transient Voltage Suppressor @ 30 Volts

### DS61 DRIVE CIRCUITRY

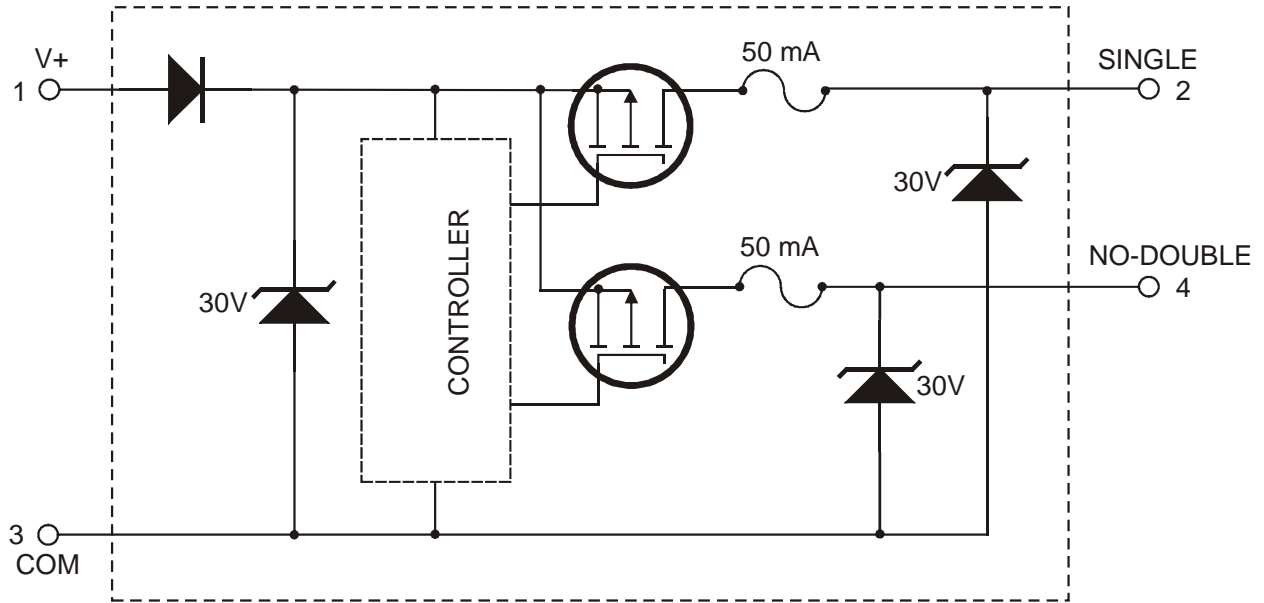

### DS62 DRIVE CIRCUITRY

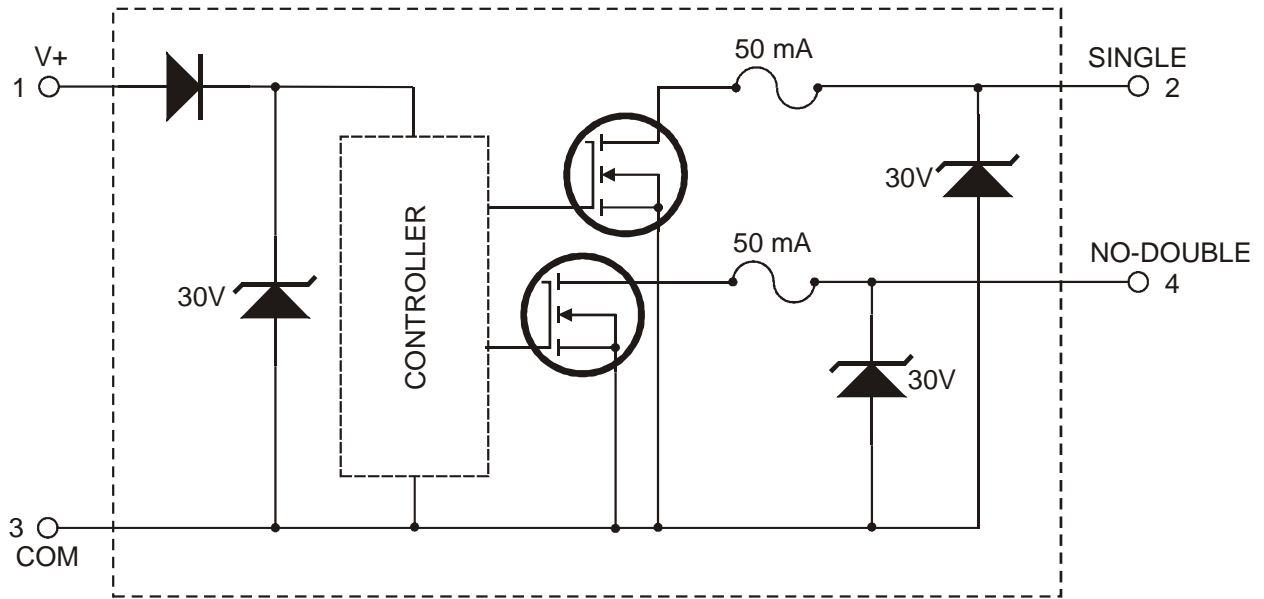

## CONTROLLER DIMENSIONS

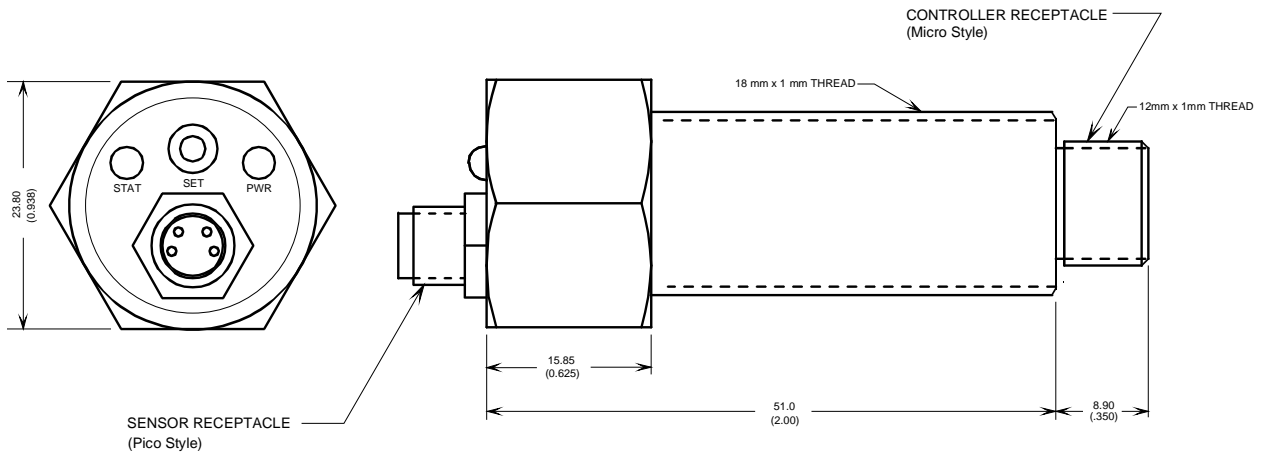

DS61/DS62 CONTROLLER HOUSING

## **LIMITATION AND EXCLUSION OF WARRANTIES**

All goods purchased from PRIME CONTROLS, INC. shall be free from defects in materials, design and workmanship under normal conditions of use for one year from the date of shipment. THIS WARRANTY IS THE SOLE WARRANTY AND IS EXPRESSLY IN LIEU OF ALL OTHER WARRANTIES, EXPRESS OR IMPLIED, INCLUDING BUT NOT LIMITED TO ANY IMPLIED, WARRANTY OF MERCHANTABILITY OF FITNESS FOR A PARTICULAR PURPOSE. THE LIABILITY OF PRIME CONTROLS TO ANY PURCHASER SHALL BE LIMITED EXCLUSIVELY TO THE COST OF REPLACEMENT OR REPAIR OF DEFECTIVE PARTS, AND SHALL NOT INCLUDE LIABILITY FOR ANY DIRECT, CONSEQUENTIAL OR INCIDENTAL DAMAGES WHATSOEVER, WHETHER FORESEEN OR UNFORESEEN, INCLUDING BUT NOT LIMITED TO LOST PROFITS, LOST SALES, OR INJURY TO PERSONS OR PROPERTY