

DOOSAN[®]

EXCAVATOR

**Operation &
Maintenance
Manual**

DX140R/DX140LCR

Serial Number 5001 and Up

K1049550HE
September 2018



WARNING

CALIFORNIA PROPOSITION 65 WARNING

Diesel engine exhaust and some of its constituents are known to the state of California to cause cancer, birth defects and other reproductive harm.



WARNING

CALIFORNIA PROPOSITION 65 WARNING

Battery posts, terminals and related accessories contain lead and lead compounds, chemicals known to the State of California to cause cancer and birth defects or other reproductive harm. WASH HANDS AFTER HANDLING.

DOOSAN[®]

Operation & Maintenance Manual

DX140R/DX140LCR EXCAVATOR

Serial Number 5001 and Up

DOOSAN and the DOOSAN logo are registered trademarks of DOOSAN Corporation in the United States and various other countries around the world.



K1049550HE
September 2018

Table of Contents

| | |
|--|------------|
| EC Declaration of Conformity | 0-1 |
| Safety | 1-1 |
| To the Operator of a DOOSAN Excavator | 1-1 |
| Safety Decals | 1-4 |
| Visibility Information | 1-19 |
| Summary of Safety Precautions for Lifting in Digging Mode..... | 1-21 |
| Unauthorized Modifications..... | 1-22 |
| General Hazard Information..... | 1-22 |
| Before Starting Engine | 1-31 |
| Machine Operation..... | 1-36 |
| Maintenance | 1-45 |
| Battery..... | 1-54 |
| Towing | 1-56 |
| Shipping and Transportation..... | 1-57 |
| Excavator Rated Lift Capacity Tables..... | 1-58 |
| Operating Controls | 2-1 |
| Component Locations | 2-2 |
| Operator's Area..... | 2-4 |
| Operational Controls and Panels | 2-6 |
| Instrument Panel..... | 2-19 |
| Multifunction Gauge and Graphic Information | 2-25 |
| Mode Selector Buttons..... | 2-31 |
| Setting Main Menu | 2-33 |
| Flow Control..... | 2-43 |
| Operation Selection Display..... | 2-45 |
| Heater and Air Conditioner Control Panel..... | 2-48 |
| Stereo | 2-53 |

| | |
|--|------|
| Miscellaneous Electrical Devices | 2-54 |
| Seat Adjustment..... | 2-56 |
| Ceiling Cover | 2-60 |
| Front Windows | 2-61 |
| Door Side Latch | 2-63 |
| Cabin Storage Compartments | 2-64 |
| Ashtray..... | 2-64 |
| Sun Visor | 2-65 |
| Hanger | 2-65 |
| Cup Holder..... | 2-65 |
| Emergency Glass Breaking Tool | 2-66 |
| Miscellaneous Access Covers and Doors..... | 2-67 |

Operation.....3-1

| | |
|--|------|
| To Handle a New Excavator | 3-1 |
| Starting and Stopping the Engine | 3-2 |
| Safety Lever..... | 3-12 |
| Travel..... | 3-13 |
| Operating Instructions..... | 3-19 |
| Operating Precautions | 3-26 |
| Parking Excavator..... | 3-31 |
| Towing Procedure..... | 3-32 |
| Hydraulic Attachments (Optional) | 3-33 |
| Adjusting the Pump Flow | 3-38 |
| Lifting Objects | 3-41 |
| Operation Under Unusual Conditions | 3-43 |
| Road Liners (Machine equipped with road liner) | 3-47 |
| Operation | 3-48 |

Inspection, Maintenance and Adjustment.....4-1

| | |
|---|-----|
| Preventive Maintenance | 4-1 |
| Preliminary Work Machine Setup for Maintenance..... | 4-4 |
| Table of Recommended Lubricants | 4-6 |

| | |
|---|------------|
| Fluid Capacities | 4-9 |
| Lubrication and Service Chart..... | 4-10 |
| Maintenance Intervals..... | 4-13 |
| 10 Hour / Daily Service | 4-15 |
| 50 Hour / Weekly Service | 4-28 |
| 250 Hour / Monthly Service..... | 4-31 |
| 500 Hour / 3 Month Service | 4-37 |
| 1,000 Hour / 6 Month Service | 4-47 |
| 2,000 Hour / Yearly Service | 4-57 |
| 4,000 Hour / Biennial Service | 4-63 |
| 12,000 Hour / 6 Year Service..... | 4-64 |
| Air-Conditioning System | 4-65 |
| Bucket..... | 4-66 |
| Electrical System | 4-68 |
| Engine Cooling System..... | 4-72 |
| Fuel Transfer Pump (Optional) | 4-75 |
| Handling of Accumulator..... | 4-78 |
| Track Tension | 4-79 |
| Venting and Priming Hydraulic System..... | 4-81 |
| Long Term Storage | 4-83 |
| Maintenance in Special Conditions..... | 4-84 |
| Transportation | 5-1 |
| Loading and Unloading..... | 5-1 |
| Lifting Machine..... | 5-6 |
| Specification | 6-1 |
| Standard Specification | 6-1 |
| Overall Dimensions..... | 6-2 |
| Working Range | 6-4 |
| Approximate Weight of Workload Materials..... | 6-8 |
| Index | 7-1 |

EC DECLARATION OF CONFORMITY

Doosan Benelux SA, Drève Richelle 167, 1410 Waterloo, (Belgium),
as authorized representative in the European Community of Doosan Infracore Co., Ltd. (Korea),
certifies that the construction equipment machinery.

Type of Machine : HYDRAULIC CRAWLER EXCAVATOR
Manufacturer : Doosan Infracore Co., Ltd., 489, Injung-ro, Dong-gu, Incheon, Korea
Technical file : Doosan Benelux SA, Drève Richelle 167, 1410 Waterloo, (Belgium)
Brand : Doosan
Model Name : DX140R/DX140LCR
Serial Number :
Year of Manufacturing. :
Engine Manufacturer : Cummins Inc
Engine Model : QSB 4.5
Net Installed Power : 71.2 kW / 1,900 rpm (SAE J1995)
Net Power :

Pertinent EC noise emission requirement :
Has been manufactured in conformity with the provisions of the Directive 2000/14/EC,
as stated below;

Certificate No. : SNCH*2000/14*2005/88*2508*00
Certification Issued Date : November 12th, 2014
Conformity Assessment Procedure : Annex VIII Full Quality Assurance
Notified Body Involved : Société Nationale de Certification et d'Homologation (SNCH)
2a. Kalchesbruck, L-1852 Luxemburg (Luxembourg)
Notified Body 0499 for EC Directive 2000/14/EC
Measured Sound Power Level : 100 dB(A)
Guaranteed Sound Power Level : 101 dB(A)

Has been manufactured in conformity with the provisions of
2006/42/EC (Machinery), 97/68/EC (Exhaust Gas Emission),
2004/108/EC or 2014/30/EU (Electromagnetic Compatibility)

Designed and manufactured in accordance with the sound engineering practice as valid for Class I
or Article 3.3 items of 97/23/EC.

B1410 - Waterloo

Signature

Sales Director

TO THE OPERATOR OF A DOOSAN EXCAVATOR



AVOID DEATH

Unsafe use of the excavator could lead to serious injury or death. Operating procedures, maintenance and equipment practices or traveling or shipping methods that do not follow the safety guidelines on the following pages could cause serious, potentially fatal injuries or extensive damage to the machine or nearby property.

Please respect the importance of taking responsibility for your own safety, and that of other people who may be affected by your actions.

The safety information on the following pages is organized into the following sections:

1. "Safety Decals" on page 1-4
2. "Visibility Information" on page 1-19
3. "Summary of Safety Precautions for Lifting in Digging Mode" on page 1-21
4. "Unauthorized Modifications" on page 1-22
5. "General Hazard Information" on page 1-22
6. "Before Starting Engine" on page 1-31
7. "Machine Operation" on page 1-36
8. "Maintenance" on page 1-45
9. "Battery" on page 1-54
10. "Towing" on page 1-56
11. "Shipping and Transportation" on page 1-57
12. "Excavator Rated Lift Capacity Tables" on page 1-58

 **WARNING**

Improper operation and maintenance of this machine can be hazardous and could result in serious injury or death.

Operator and maintenance personnel should read this manual thoroughly before beginning operation or maintenance.

Keep this manual in the storage compartment to the rear of the operator's seat, and have all personnel involved in working on the machine read the manual periodically.

Some actions involved in operation and maintenance of the machine can cause a serious accident, if they are not done in a manner described in this manual.

The procedures and precautions given in this manual apply only to intended uses of the machine.

If you use your machine for any unintended uses that are not specifically prohibited, you must be sure that it is safe for any others. In no event should you or others engage in prohibited uses or actions as described in this manual.

DOOSAN delivers machines that comply with all applicable regulations and standards of the country to which it has been sent. If this machine has been purchased in another country or purchased from someone in another country, it may lack certain safety devices and specifications that are necessary for use in your country. If there is any question about whether your product complies with the applicable standards and regulations of your country, consult DOOSAN or your DOOSAN distributor before operating the machine.

 **SAFETY ALERT SYMBOL** 

Be Prepared - Get to Know All Operating and Safety Instructions.

This is the Safety Alert Symbol. Wherever it appears in this manual or on safety signs on the machine you must be alert to the potential for personal injury or accidents. Always observe safety precautions and follow recommended procedures.

Learn Signal Words Used with Safety Alert Symbol

The words "CAUTION", "WARNING", and "DANGER" used throughout this manual and on decals on the machine indicate degree of risk of hazards or unsafe practices. All three degrees of risk indicate that safety is involved. Observe precautions indicated whenever you see the Safety Alert "Triangle", no matter which signal word appears next to "Exclamation Point" symbol.

CAUTION

This word is used on safety messages and safety labels and indicates potential of a hazardous situation that, if not avoided, could result in minor or moderate injury. It may also be used to alert against a generally unsafe practice.

WARNING

This word is used on safety messages and safety labels and indicates potential threat of a hazardous situation that, if not avoided, could result in serious injury or death. It may also be used to alert against highly unsafe practice.

DANGER

This word is used on safety messages and safety labels and indicates an imminent hazard of a situation that, if not avoided, is very likely to cause death or extremely serious injury. It may also be used to alert against equipment that may detonate or explode if handled or treated carelessly.

Other Signal Words

In addition to safety signal words, the following signal words are used to indicate proper and effective use of machine.

IMPORTANT

This signal word identifies procedures which must be followed to avoid damage to machine.

NOTE: *The word "NOTE" identifies information for effective use.*

SAFETY DECALS

Safety decals are attached to the machine to alert the operator or maintenance person about potential hazards, the consequences of potential injury, and instructions and/or actions required to avoid the hazard. The location of the safety decals and the description of the decals are reviewed in the following section. Please become familiarized with all safety decals and their messages.

Make sure that all the safety decals are in their correct location and legible. Clean or replace the safety decals if they are damaged, missing, or the texts and pictorials are not legible. When you clean the safety decals, use a soft cloth, water, and soap. Do not use solvent, gasoline, or other harsh chemicals to clean the safety decals because this could loosen the adhesive that secures the decals to the machine. Remember, if a safety decal is attached to a part that is replaced, install a new safety decal on the replacement part.

This machine uses safety decals with and without text. The type and number of safety decals can vary depending upon geographical regions and machine models.

Safety Decals With Text

Safety decals with text consist of a signal word, pictorial and a text message panel. In some cases, a pictorial panel may not be part of the safety decal.

Safety Decals Without Text (No-Text)

Safety decals without text consist of a safety sign and safety information panel. The safety sign panel is located at the top or left side and the safety information panel is located at the bottom or right side of the decal depending on its configuration. The safety sign panel uses a black triangular band and a pictorial to identify the hazard and the potential consequences of the failure to follow instructions. The safety information panel uses pictorials and/or prohibition signs to identify the actions necessary to avoid the hazard.

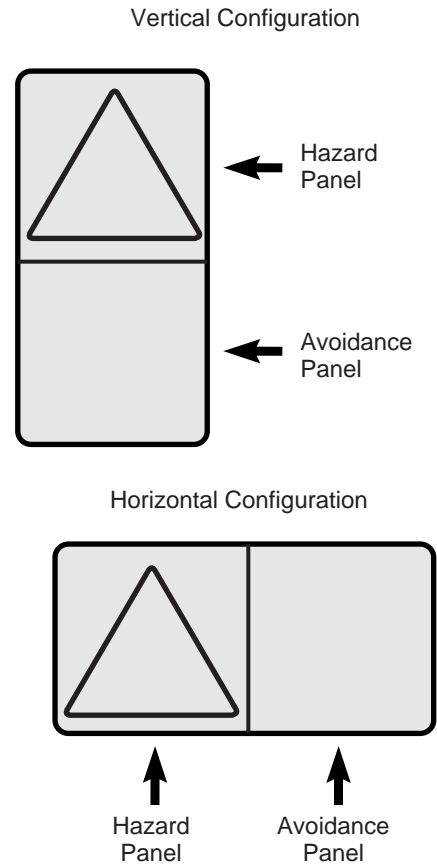

FG018723

Figure 1

Information and Location for Safety Decals

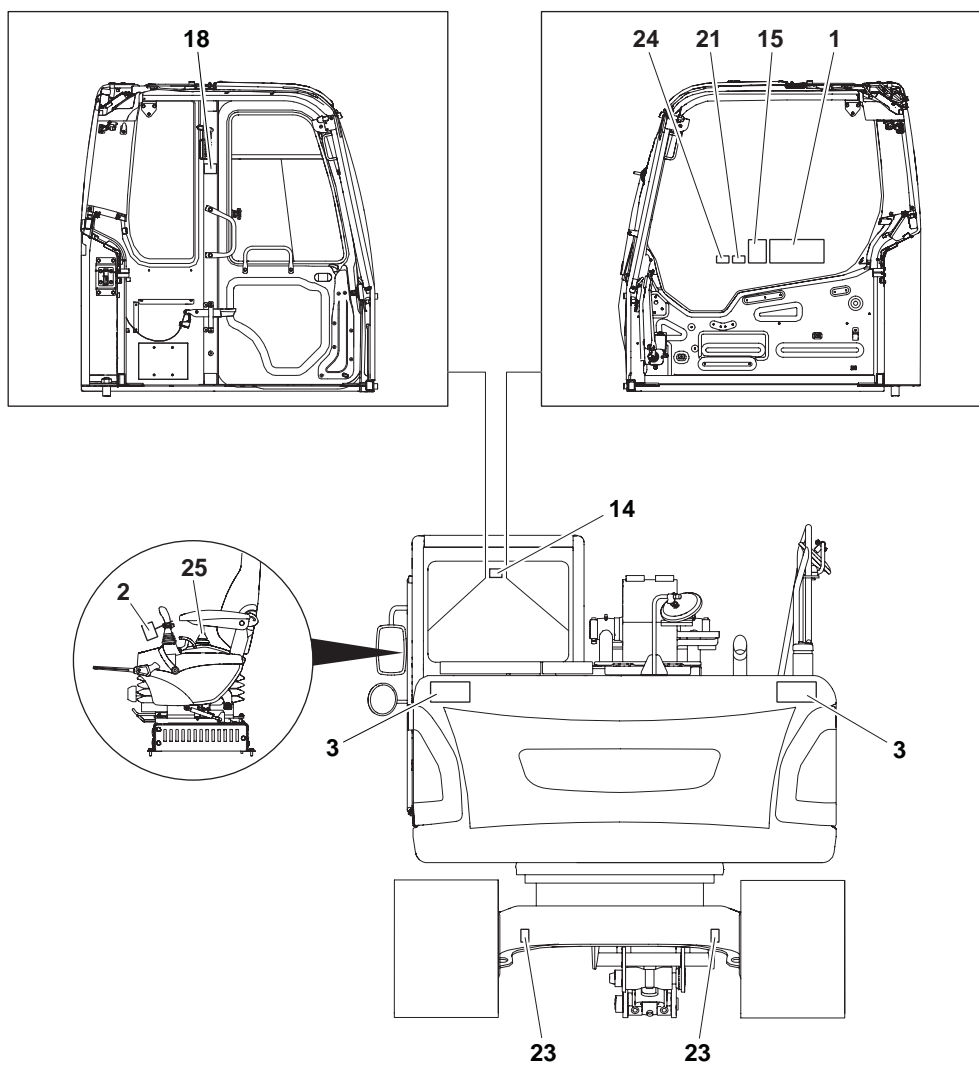

EX1402440

Figure 2

Information and Location for Safety Decals (Continued)

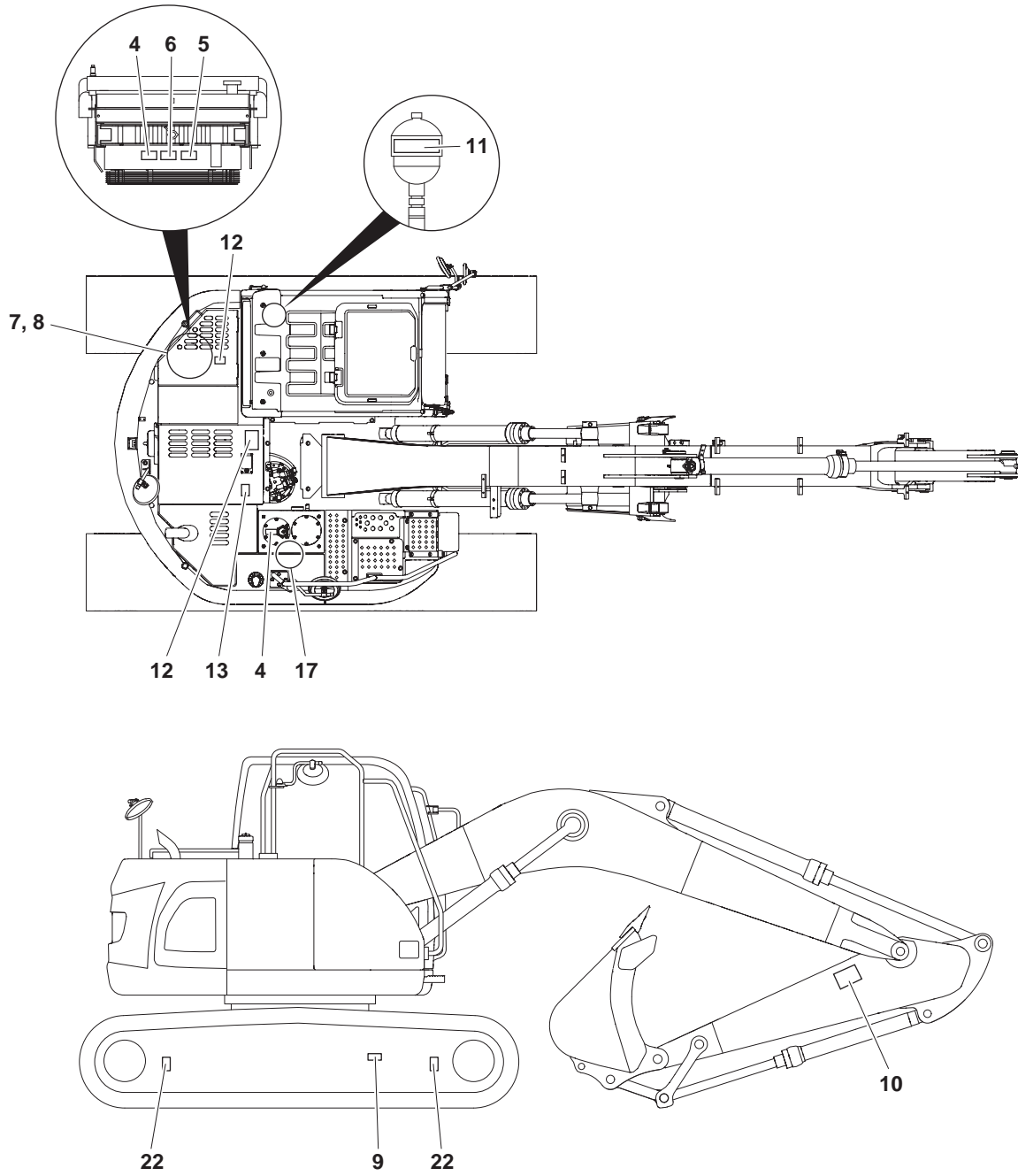
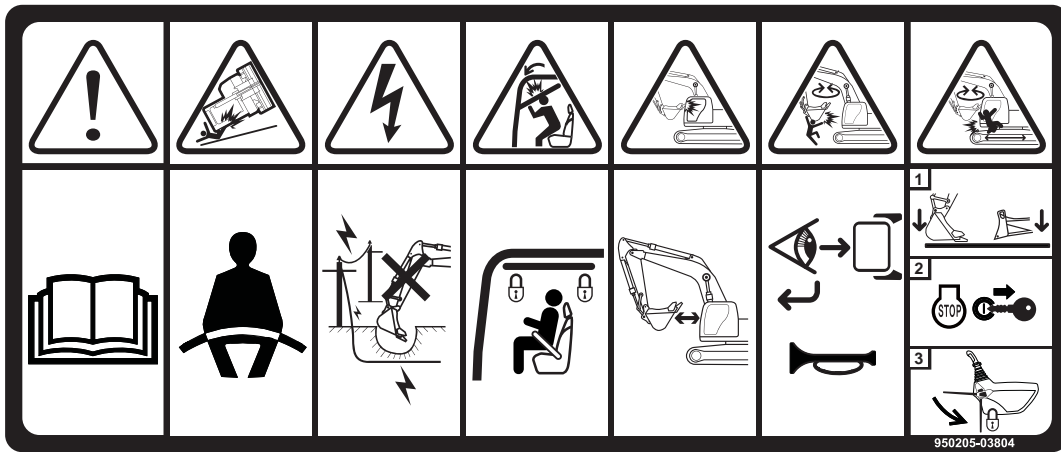

Figure 3

EX1402399

1. General Hazard (950205-03804)



EX1301176

 **WARNING**

AVOID DEATH OR SERIOUS INJURY

- Never use excavator without instructions.
- Read Operation & Maintenance Manual before operation.
- Sound the horn to alert bystanders before operating.
- Always fasten your seat belt.
- Explosion or electrocution can occur if machine contacts utility lines or pipes. Check for overhead or underground lines before operating.
- Secure and lock front window when it is in raised position.
- Attachment interference can cause death, serious injury or machine damage. Check attachment to machine clearance through full working cycle before operation.
- Keep bystanders out of swing area and travel path and always look in the travel direction.
- Ensure mirrors and rear view camera are clean and working properly.
- Never operate machine from outside the operator's position.
- TO LEAVE THE EXCAVATOR:
 - 1) Lower the attachment and dozer blade (if equipped) to the ground and make sure all controls are in neutral.
 - 2) Stop engine and remove key.
 - 3) Lower safety lever to LOCK position.

2. Warning Tag - "Do Not Operate" (950205-03802)



AVOID DEATH OR SERIOUS INJURY

- Stop engine and remove key.
- Attach "DO NOT OPERATE" warning tag to the controls before servicing the machine.
- Do not operate when performing inspection or maintenance.

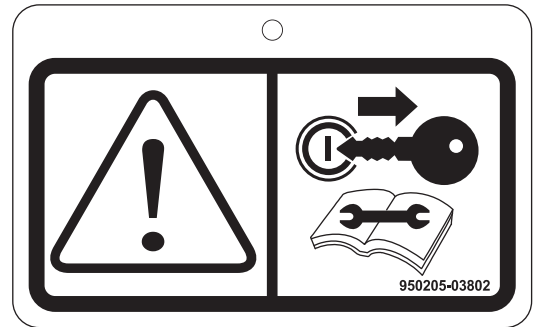

EX1301177

3. Keep Bystanders Away (950205-03803)



AVOID DEATH OR SERIOUS INJURY

- Keep out of swing area and travel path.
- Always look in the travel direction.
- Make sure swing area is clear of bystanders and objects.

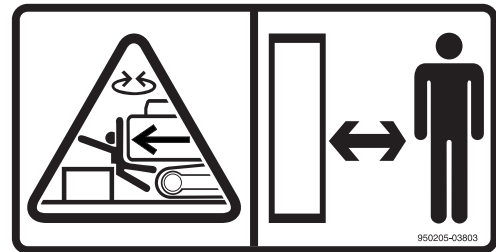

EX1301178

4. Hot Pressurized Fluid (950205-03781)



HOT PRESSURIZED FLUID CAN CAUSE
SERIOUS BURNS

- Do not loosen or open cap when hot.
- Before opening:
 - 1) Turn engine off.
 - 2) Allow machine to cool.
 - 3) Tip cap and open slowly to relieve pressure.



EX1301180

5. Entanglement in Rotating Parts (950205-03791)



ROTATING PARTS CAN CAUSE DEATH OR
SERIOUS INJURY

Keep away from belt and rotating parts. Stop engine
before servicing.

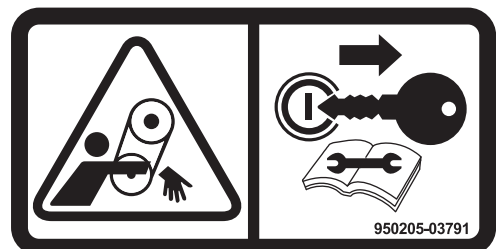

EX1301181

6. Rotating Fan (950205-03788)



WARNING

CONTACT WITH ROTATING FAN CAN CAUSE
DEATH OR SERIOUS INJURY

Keep away from fan and rotating parts. Stop engine
before servicing.

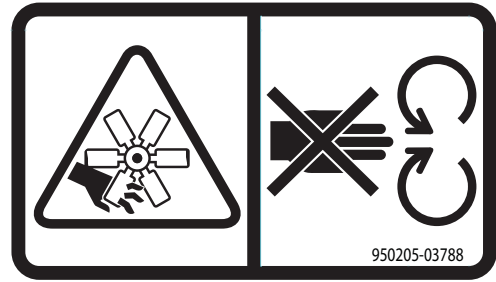

950205-03788

EX1301182

7. Battery Explosion (950205-03785)



WARNING

AVOID DEATH OR SERIOUS INJURY

- Read and follow instructions in Operation & Maintenance Manual for battery maintenance.
- Keep arcs, sparks, flames, and lighted tobacco away.
- Do not store metal tools or flammable materials on or around batteries.
- Wear safety goggles and rubber gloves when working with batteries.
- If battery acid contact occurs:
 - 1) Flush your skin with water immediately and apply baking soda or lime to neutralize the acid.
 - 2) Flush your eyes with water for 10 - 15 minutes.
 - 3) Get medical attention immediately.



950205-03785

EX1301183

8. Battery Disconnection (950205-03784)

IMPORTANT

AVOID ELECTRICAL COMPONENT DAMAGE

Disconnecting the battery while the engine is running
can cause damage to electrical components.

Disconnect battery only when the engine is turned
OFF.

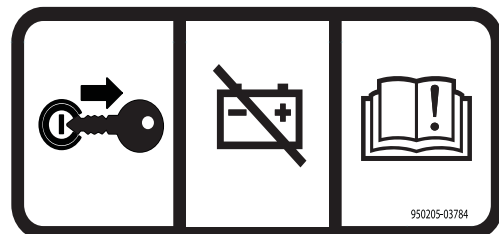

950205-03784

EX1301184

9. Flying Debris or Objects (950205-03866)



WARNING

**HIGH-PRESSURE GREASE CAN CAUSE
DEATH OR SERIOUS INJURY**

- Track adjusting systems use grease under high-pressure which can penetrate body if improperly serviced.
- **NEVER LOOSEN** track tension grease valve more than one complete turn from the fully tightened position.
- Bleed off pressure slowly and keep body away from grease valve.
- Wear eye protection.
- Read and follow instructions in Operation & Maintenance Manual for more information on track adjustment.

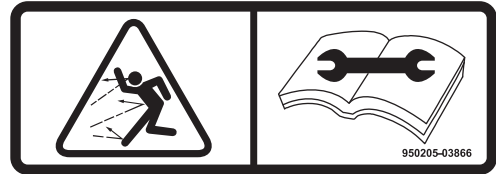

EX1301185

10. Crush Hazard (950205-03805)



WARNING

AVOID DEATH OR SERIOUS INJURY

Stay clear of the boom, arm, and attachment.



EX1301186

11. Pressurized Gas and Fluid (950205-03782)



WARNING

AVOID DEATH OR SERIOUS INJURY

- Heat or impact can cause the accumulator to explode.
- Keep away from flame.
- Do not weld on or drill into accumulator.



EX1301187

12. Fall Hazard (950205-03783)

 **WARNING**

AVOID DEATH OR SERIOUS INJURY

Do not step in this area.



EX1301188

13. Hot Surface (950205-03777)

 **WARNING**

HOT SURFACE CAN CAUSE SERIOUS BURNS

- Do not touch hot surface.
- Allow to cool before servicing.



EX1301189

14. Emergency Exit (950205-03810)

IMPORTANT

If primary exit is blocked, use glass breaking tool to break glass for secondary exit.

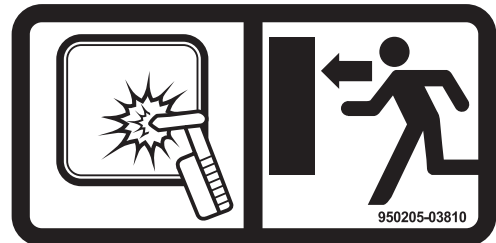

EX1301190

15. ISO Control Pattern (950205-03860)



AVOID INJURY OR DEATH

Read and understand the Operation & Maintenance Manual for more information.

Refer to "Operating Instructions" section of this manual for details regarding the work levers (joysticks) control functions.

BHL Control Pattern (US Only) (950205-03868)



AVOID INJURY OR DEATH

Read and understand the Operation & Maintenance Manual for more information.

Refer to "Operating Instructions" section of this manual for details regarding the work levers (joysticks) control functions.

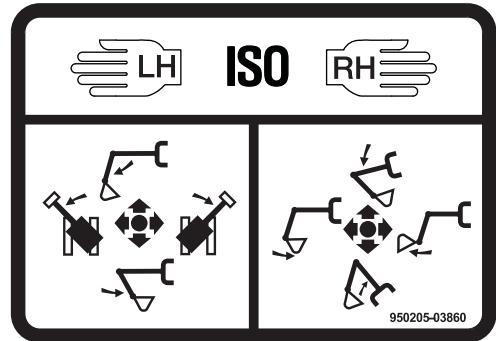

EX1301191

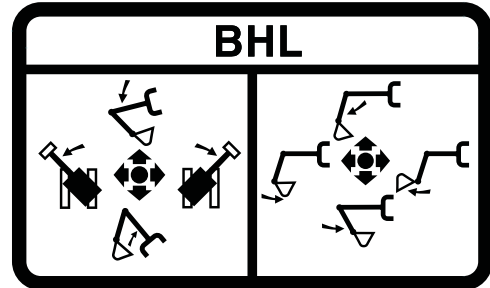

EX1301192

16. Impact Hazard (Optional) (950205-03963)



AVOID DEATH OR SERIOUS INJURY

- Activating the Intelligent Floating Boom Control with the tracks raised up can cause the machine to drop suddenly.
- Do not activate Intelligent Floating Boom Control when tracks are raised.
- Do not raise tracks when control is activated.

Refer to "Intelligent Floating Boom Control (Optional)" section of this manual for more information.

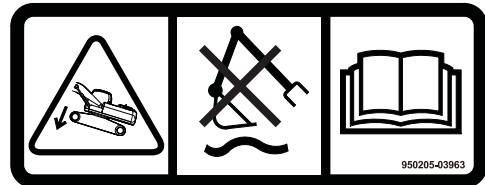

EX1301193

17. Ultra Low Sulfur Diesel Fuel (Optional)
(950205-03863, 950205-03864)

IMPORTANT

Only use Ultra Low Sulfur Diesel (ULSD) fuel with this machine.

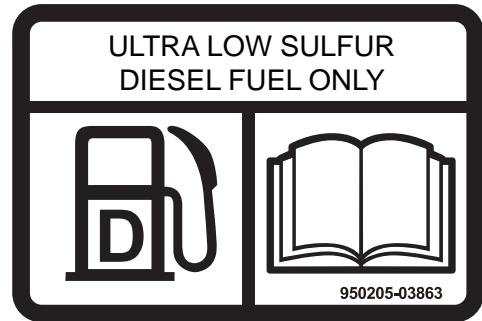

EX1301196



EX1301194

18. ROPS Warning (Optional) (950205-03861)

 **WARNING**

AVOID DEATH OR SERIOUS INJURY

- Do not weld on or drill holes in the protective structure.
 - Replace ROPS, if damaged or modified.
-

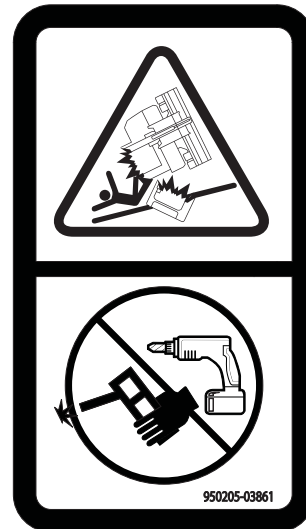

EX1301197

19. Falling Object (Optional) (950205-03786)



WARNING

**UNSUPPORTED DOOR CAN FALL CAUSING
DEATH OR SERIOUS INJURY**

- To open door:
 - 1) Hold door firmly.
 - 2) Lift door slowly until locking device engages.
 - To close door:
 - 1) Hold door firmly.
 - 2) Press locking device to disengage.
 - 3) Lower door slowly.
-



EX1301198

20. Hydraulic Oil Check (Optional)
(950205-06281, 950205-03965, 950205-06282)

IMPORTANT

**INCORRECT OIL LEVEL OR INCORRECT FLUID CAN
CAUSE HYDRAULIC SYSTEM DAMAGE**

Place the excavator with the boom and arm fully
extended with the attachment on the ground before
checking hydraulic fluid level.

Use hydraulic oil which is suitable for machine.

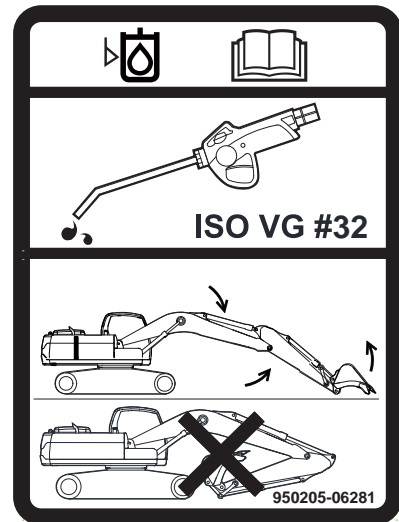

EX1505097

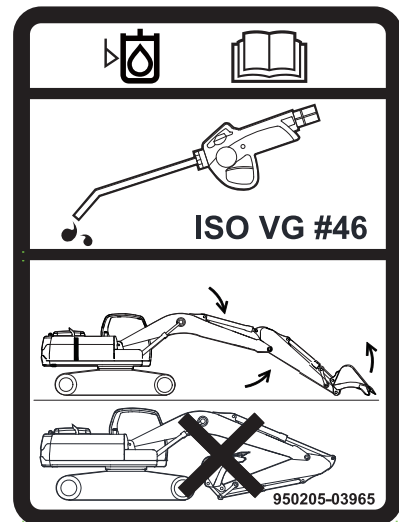

EX1505098

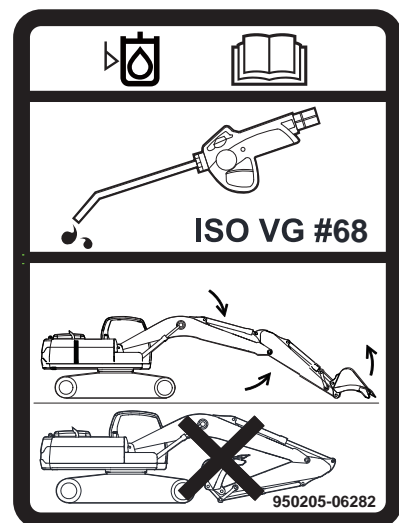

EX1505099

21. Hydraulic Breaker (Optional) (950205-03964)

IMPORTANT

AVOID HYDRAULIC SYSTEM DAMAGE

To adjust breaker impact, see Operation & Maintenance Manual for additional instructions.

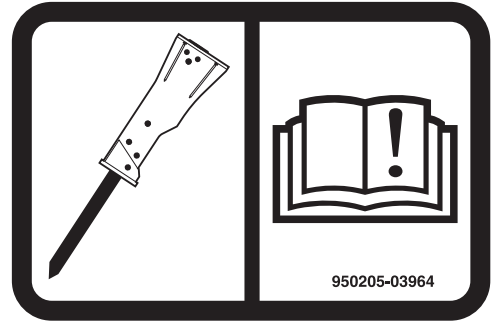

EX1301200

22. Lift/Tie down (Optional) (950205-03815)

Identifies lift point and tie down point location.

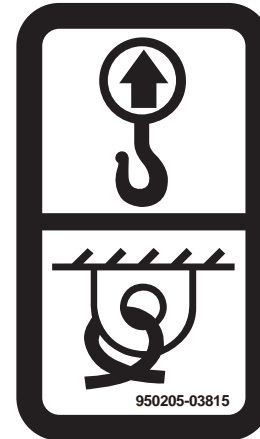

EX1301201

23. Tie down (Optional) (950205-03816)

Identifies tie down point location.

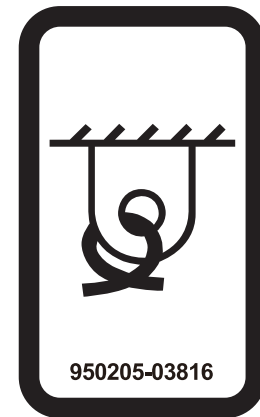

EX1301203

24. Electric Welding Attention (950212-02440)

IMPORTANT

Electrical welding on the frame can damage the engine's electronic control unit (ECU).

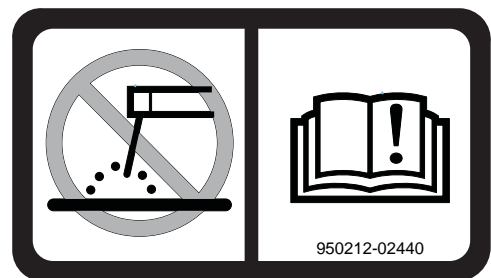

EX1402396

25. Dozer (950205-03881)



WARNING

AVOID DEATH OR SERIOUS INJURY

- Check the dozer blade location before traveling. When the blade is to the rear, operate the steering levers/foot pedal in the opposite direction to when the blade is in the front.
- Before moving, make sure there are no persons or property in the way. Never allow riders. Sound the horn to alert workers and bystanders that you are about to move the machine.
- Always make sure the path is clear during travel.
- Use extreme caution when reversing travel. Be sure there is a clear path behind the machine.
- Operate the travel control levers smoothly to avoid sudden starts or stops.
- Before leaving the operator's seat, make sure to lock out all control systems and stop engine to avoid accidental activation of the controls.

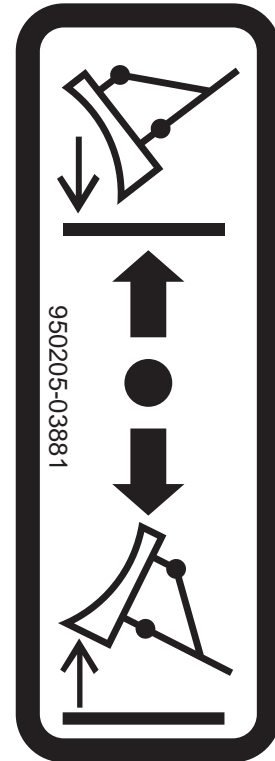

EX1402247

VISIBILITY INFORMATION

A rear view camera and mirrors ensure that visibility around the machine, from the operator's seat, meets the latest ISO standards for the region or marketplace that the machine is sold into.

NOTE: *These devices may vary from one region to another, depending upon local and regional regulations. If a machine is moved or sold into another region or marketplace, it is the owner's responsibility to make sure it complies with all regulations.*

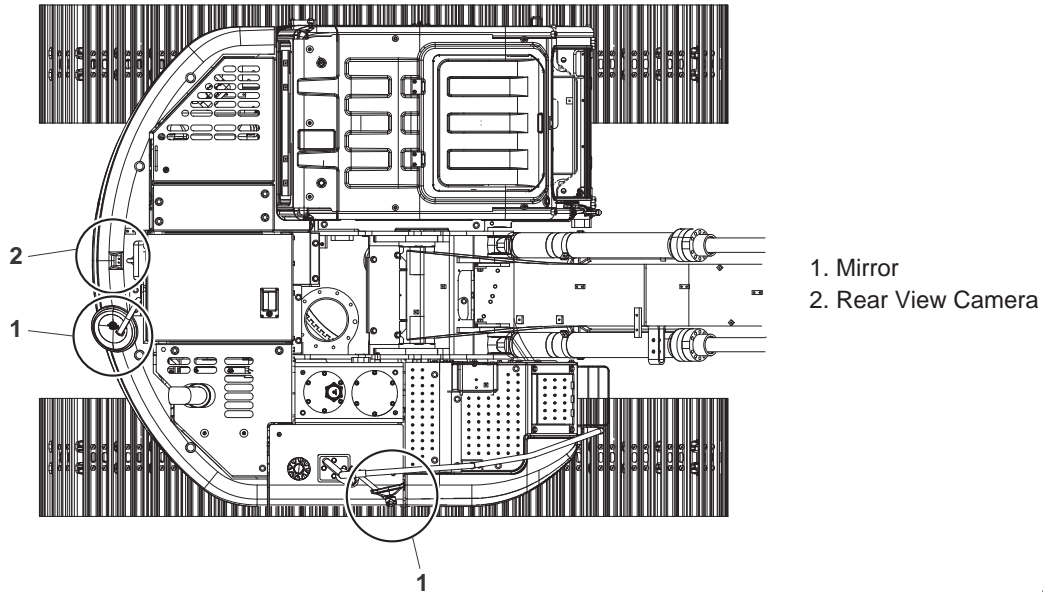

Figure 4

FG016320



WARNING

AVOID DEATH OR SERIOUS INJURY

Failure to check for and clear people from the surrounding area of a machine could result in serious injury or death. The operator should make sure that visual aids (mirrors and camera(s)) are in proper working condition. Look for any possible blind spots.

Your machine may be equipped with visual aids; mirrors or cameras, but even with these aids, there still may be blind spots which cannot be seen from the operator's seat, so always be careful when operating.

Adjust the visual aids for the best visibility criteria for all areas around the machine.

When swinging or backing up, press button to change display mode on monitor so you can check rear and side of machine. Before moving the machine, look around the work site through mirrors and monitor to confirm that no one is around the machine.

While operating or traveling in places with poor visibility, and if it is impossible to confirm the condition of the work site, or if an obstacle is in the area around the machine, there can be a danger that the machine may suffer damage or operator or others may suffer serious personal injury.

Inspect equipment and immediately report if there are problems with the visual aids. If machine cannot be fixed immediately, DO NOT use the machine. Contact your local DOOSAN distributor as soon as possible and ask for repairs.

Guidelines

- If the visibility cannot be sufficiently assured, use a flagman. The operator should pay careful attention to the signals and follow the instructions of the flagman.
- Signals should only be given by one flagman.
- When working in dark places, turn "ON" work lights and front lights on the machine. Set up additional lighting in the area.
- Stop operations if there is poor visibility, such as fog, snow, rain, or sandstorms.
- Check mirrors and rear view camera (optional) lens on machine before starting operations. Clean off any dirt and adjust view to ensure good visibility.

When operating or traveling during poor visibility conditions, and especially in a large machine, strictly adhere to the above guidelines.

NOTE: *Refer to ISO 5006 for additional guidelines and information.*

It may not be possible to adjust all visual aids to see all the way around the machine. Therefore, additional precautions must be taken to ensure the safe operation of the machine.

NOTE: *Larger machines are more likely to have blind spots.*

NOTE: *Refer to ISO 5006 for weight class information.*

SUMMARY OF SAFETY PRECAUTIONS FOR LIFTING IN DIGGING MODE

DANGER

AVOID DEATH

Unsafe use of the excavator while making rated lifts could cause serious, potentially fatal injuries or extensive damage to the machine or nearby property. Do not let anyone operate the machine unless they've been properly trained and understand the information in the Operation and Maintenance Manual.

To lift safely while in Digging Mode, the following items must be evaluated by the operator and the work site crew.

- Condition of ground support.
- Excavator configuration and attachments.
- Weight, lifting height and lifting radius.
- Safe rigging of the load.
- Proper handling of the suspended load.

Tag lines on opposite sides of the load can be very helpful in keeping a suspended load secure, if they are anchored safely to control points on the ground.

WARNING

AVOID DEATH OR SERIOUS INJURY

NEVER wrap a tag line around your hands or body.

NEVER rely on tag lines or make rated lifts when wind gusts are more than 48.3 km/h (30 MPH). Be prepared for any wind gust when working with loads that have a large surface area.

Always engage the "Digging Mode" control on the Instrument Panel before using the excavator for lifting work.



WARNING

AVOID DEATH OR SERIOUS INJURY

If you need more information or have any questions or concerns about safe operating procedures or working the excavator correctly in a particular application or in the specific conditions of your individual operating environment, please consult your local DOOSAN representative.

UNAUTHORIZED MODIFICATIONS

Any modification made without authorization or written approval from DOOSAN can create a safety hazard, for which the machine owner will be held responsible.

For safety's sake, replace all OEM parts with the correct authorized or genuine DOOSAN part. For example, not taking the time to replace fasteners, bolts or nuts with the correct replacement parts could lead to a condition where the safety of critical assemblies are dangerously compromised.

GENERAL HAZARD INFORMATION

Safety Rules

Only trained and authorized personnel can operate and maintain the machine.

Follow all safety rules, precautions and instructions when operating or performing maintenance on the machine.

Do not operate the machine if you are not feeling well, if you are taking medication that makes you feel sleepy, if you have been drinking, or if you are suffering from emotional problems. These problems will interfere with your sense of judgment in emergencies and can cause accidents.

When working with another operator or with a person on work site traffic duty, be sure that all personnel know the nature of the work and understand all hand signals that are to be used.

Always observe strictly any other rules related to safety.

Safety Features

Be sure that all guards and covers are installed in their proper position. Have guards and covers repaired immediately if damaged.

Be sure that you understand the method of use of safety features such as safety lock lever and the seat belt, and use them properly.

Never remove any safety features. Always keep them in good operating condition.

Failure to use safety features according to the instructions in the Operation and Maintenance Manual could result in serious bodily injury.

Inside Operator's Cabin

When entering the operator's cabin, always remove all mud and oil from the soles of your shoes. If you operate the travel pedal with mud or oil stuck to your shoes, your foot may slip and this can cause a serious accident.

After using the ashtray, make sure that any matches or cigarettes are properly extinguished, and be sure to close the ashtray. If the ashtray is left open, there is a danger of fire.

Do not stick suction pads to the window glass. Suction pads act as a lens and can cause fire.

Do not leave lighters laying around the operator's cabin. If the temperature inside the operator's cabin becomes high, there is a danger that lighter may explode.

Do not use cellular telephones inside the operator's cabin when driving or operating the machine. There is a danger that this may lead to an unexpected accident.

Never bring any dangerous objects such as flammable or explosive items into the operator's cabin.

To ensure safety, do not use the radio or music headphones when operating the machine. There is a danger that this may lead to a serious accident.

When operating the machine, do not put your hands or head out of the window.

When standing up from the operator's seat, always place safety lock lever securely in the "LOCK" position. If you accidentally touch the work equipment levers when they are not locked, the machine may suddenly move and cause serious injury or damage.

When leaving the machine, completely lower the work equipment to the ground, set safety lock lever to "LOCK" position and stop engine. Use the key to lock all the equipment. Always remove key and take it with you.

Clothing and Personal Protective Items

Secure long hair, and avoid loose clothing and jewelry. These items have the tendency to catch on controls or protrude into parts and cause serious injury or death.

Do not wear oily clothes. They are flammable.

Full eye protection, a hard hat, safety shoes and gloves may be required at the work site.

While working on the machine, never use inadequate tools. They could break or slip, causing injury, or they may not adequately perform intended functions.



Figure 5

Breathing Masks, Ear Protection May Be Required

Do not forget that some risks to your health may not be immediately apparent. Exhaust gases and noise pollution may not be visible, but these hazards can cause disabling or permanent injuries.

NOTE: *The equivalent continuous A-weighted sound pressure level at the workstation for this machine is 71 dB(A).*

Measurement is obtained on a dynamic machine following the procedures and cabin conditions as described in ISO 6396.

NOTE: *The guaranteed sound power level emitted by the machinery for this machine is 101 dB(A).*

Measurement is obtained on a dynamic machine with the procedures as described in 2000/14/EC.

Vibration Level Information

Hands/Arms: The weighted root mean square acceleration to which the hands/arms are subjected, is less than 2.5 m/s².

Whole body: The weighted root mean square acceleration to which the whole body is subjected, is less than 0.5 m/s².

Measurements are obtained on a representative machine, using measuring procedures as described in the following standard: ISO 2631/1, ISO 5349, and SAE J1166.

Recommendations for Limiting Vibrations

1. Select the right machine, equipment and attachments for a particular application.
2. Replace any damaged seat by a DOOSAN genuine part. Keep the seat maintained and adjusted.
 - Adjust the seat and suspension for the weight and size of the operator.
 - Inspect and maintain the suspension and adjustment mechanisms of the seat regularly.
3. Check that the machine is properly maintained.
 - Tire pressure, brakes, steering, linkages, etc.
4. Steer, brake, accelerate, shift gears, move the attachments and load the attachments smoothly.
5. Adjust the machine speed and travel path to reduce the vibration level.
 - Slow down if it is necessary when traveling through rough terrain.
 - When driving machine, avoid obstacles and excessive rough terrain.
6. Keep the machine on terrain where working and traveling conditions are good.
 - Remove any large rocks or obstacles.
 - Fill any ditches and holes.
 - Provide machines for and schedule time to maintain good terrain conditions.
7. Travel over longer distances (e.g. on public roads) at adjusted (medium) speed.
 - Always adjust the speed to prevent bouncing.

Mounting and Dismounting

Before getting on or off the machine, if there is any oil, grease, or mud on the handrails, steps, or track shoes, wipe it off immediately. Always keep these parts clean. Repair any damage and tighten any loose bolts.

Never jump on or off the machine. In particular, never get on or off a moving machine. These actions may lead to serious injury.

When getting on or off the machine, always face the machine, and maintain three-point contact (both feet and one hand or one foot and both hands) with the handrails, steps, and track shoes to ensure that you support yourself securely.

Never hold any control levers when getting on or off the machine.

Apply the door lock securely. If you grip the handrail inside the door when moving on top of the track shoes, and the door lock is not applied securely, the door may move and cause you to fall.

Use the points marked by arrows in the diagram when getting on or off the machine.

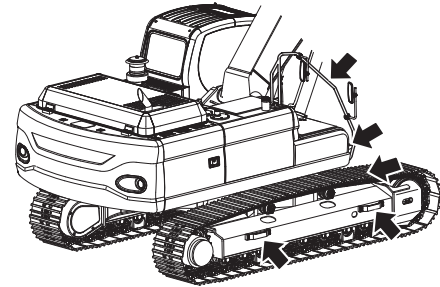
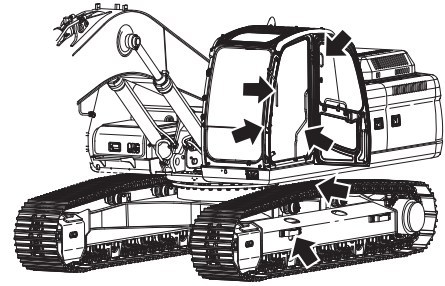

Figure 6

FG000355

Fuel, Oil and Hydraulic Fluid Fire Hazards

Fuel, oil and antifreeze will catch fire if it is brought close to a flame. Fuel is particularly flammable and can be hazardous.

Always strictly observe the following.

Add fuel, oil, antifreeze and hydraulic fluid to the machine only in a well ventilated area. The machine must be parked with controls, lights and switches turned "OFF". The engine must be "OFF" and any flames, glowing embers, auxiliary heating units or spark causing equipment must be extinguished, turned "OFF" and/or kept well clear of the machine.

Static electricity can produce dangerous sparks at the fuel filling nozzle. In very cold, dry weather or other conditions that could produce a static discharge, keep the tip of the fuel nozzle in constant contact with the neck of the fuel filling nozzle, to provide a ground.

Keep fuel and other fluid reservoir caps tight and do not start the engine until caps have been secured.



Figure 7

ARO1050S

Precautions When Handling Fluids at High Temperature

Immediately after operations are stopped, the coolant, engine oil, and hydraulic oil are at highest temperatures and the radiator and hydraulic tank are still under pressure. Attempting to remove cap, drain the oil or coolant, or replacing the filters may lead to serious burns. Always wait for the temperature to go down, and follow the specified procedures when carrying out these operations.

To prevent hot coolant from spurting out, stop engine, wait for the coolant to cool, then loosen the cap slowly to relieve the pressure.

To prevent hot oil from spurting out, stop engine, wait for the oil to cool, then loosen the cap slowly to relieve the pressure.



Figure 8

HAOA050L



Figure 9

HAOA060L

Asbestos Dust Hazard Prevention

Asbestos dust can be HAZARDOUS to your health if it is inhaled. Materials containing asbestos fiber can be present on work site. Breathing air that contains asbestos fiber can ultimately cause serious or fatal lung damage. To prevent lung damage from asbestos fiber, observe following precautions:

- Use a respirator that is approved for use in an asbestos-laden atmosphere.
- Never use compressed air for cleaning.
- Use water for cleaning to keep down the dust.
- Work on the machine or component with the wind at your back whenever possible.
- Always observe any regulations related to the work site and working environment.



Figure 10

ARO1770L

Injury from Work Equipment

Do not enter or put your hand, arm or any other part of your body between movable parts, such as between the work equipment and cylinders, or between the machine and work equipment.

If the control levers are operated, the clearance between the machine and the work equipment will change and this may lead to serious damage or personal injury.

If going between movable parts is necessary, always position and secure the work equipment so it cannot move.



HDO1010L

Figure 11

Fire Extinguisher and First Aid Kit

As a precaution if any injury or fire should occur, always do the following.

- Be sure that fire extinguishers have been provided and read the labels to ensure that you know how to use them. It is recommended that an appropriately sized (2.27 kg [5 lb] or larger) multipurpose "A/B/C" fire extinguisher be mounted in the cabin. Check and service the fire extinguisher at regular intervals and make sure that all work site crew members are adequately trained in its use.
- Provide a first aid kit in the storage compartment and keep another at the work site. Check the kit periodically and make any additions if necessary.
- Know what to do in case of injury from fire.
- Keep emergency numbers for doctor, ambulance service, hospital and fire department near your telephone.

If the machine catches fire, it may lead to serious personal injury or death. If a fire occurs during operation, escape from the machine as follows:

- Turn the starter switch to "O" (OFF) position and stop engine.
- If there is time, use the fire extinguisher to put out as much of the fire as possible.
- Use the handrails and steps to escape from the machine.

The above is the basic method for escaping from the machine, but changing the method may be necessary according to the conditions, so carry out practice drills at the work site.

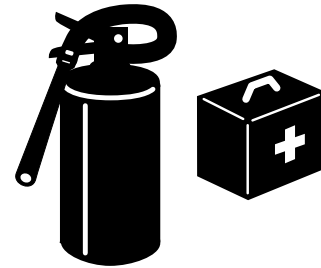

HDO1009L

Figure 12

Protection from Falling or Flying Objects

On work sites where there is a danger that falling or flying objects may hit the operator's cabin select a guard to match the operating conditions to protect the operator.

Working in mines, tunnels, deep pits or on loose or wet surfaces could produce danger of falling rock or hazardous flying objects. Additional protection for the operator's cabin could be required in the form of a FOPS (Falling Object Protective Structure) or window guards.

Never attempt to alter or modify any protective structure reinforcement system, by drilling holes, welding, remounting or relocating fasteners. Any serious impact or damage to the system requires a complete integrity reevaluation. Reinstallation, recertification and/or replacement of the system may be necessary.

Contact your DOOSAN distributor for available safety guards and/or recommendations to prevent danger of getting hit by objects that could strike the operator's cabin. Make sure that all other work site crew members are kept well away from the excavator and safe from possible hazards.

For breaker operation, install a front guard and apply a laminated coating sheet to the front glass. Contact your DOOSAN distributor for recommendations.

When carrying out demolition or cutting operation, install a front guard and top guard, and apply a laminated coating sheet to the front glass.

When working in mines or quarries where there is a danger of falling rock, install FOPS (Falling Objects Protective Structure) and apply a laminated coating sheet to the front glass.

If any glass on the machine is broken, replace it with new glass immediately.

Attachment Precautions

Option kits are available through your dealer. Contact DOOSAN for information on available one-way (single-acting) and two-way (double-acting) piping/valving/auxiliary control kits. Because DOOSAN cannot anticipate, identify or test all the attachments that owners may wish to install on their machines, please contact DOOSAN for authorization and approval of attachments, and their compatibility with optional kits.

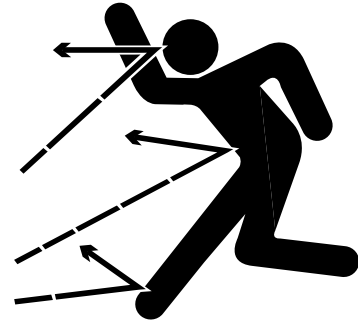

HAOA110L

Figure 13



HAOA100L

Figure 14

Accumulator

The pilot control system is equipped with an accumulator. For a brief period of time after the engine has been stopped, accumulator will store a pressure charge that may enable hydraulic controls to be activated. Activation of any controls may enable the selected function to operate under force of gravity.

When performing maintenance on the pilot control system, the hydraulic pressure in the system must be released as described in "Handling of Accumulator" on page 4-78.

The accumulator is charged with high-pressure nitrogen gas, so it is extremely dangerous if it is handled in the wrong way. Always observe the following precautions:

- Do not drill or make any holes in the accumulator or expose it to any flames, fire or heat source.
- Do not weld on the accumulator, or try attaching anything to it.
- When carrying out disassembly or maintenance of the accumulator, or when disposing of the accumulator, the charged gas must be properly released. Contact your DOOSAN distributor.
- Wear safety goggles and protective gloves when working on an accumulator. Hydraulic oil under pressure can penetrate the skin and cause serious injuries.

Indoor Ventilation

Engine exhaust gases can cause fatal accidents, and unconsciousness, loss of alertness, judgment and motor control and serious injury.

Make sure there is adequate ventilation before starting the engine in any enclosed area.

You should also be aware of open windows, doors or ductwork where exhaust may be carried, or blown by the wind, exposing others to danger.



Figure 15

ARO1770L

Emergency Exit

This machine is equipped with a glass breaking tool. It is located to the left pillar of the cabin. This tool can be used in case of an emergency that requires the breaking of glass to exit from the cabin. Grip the handle firmly and use the sharp point to break the glass.

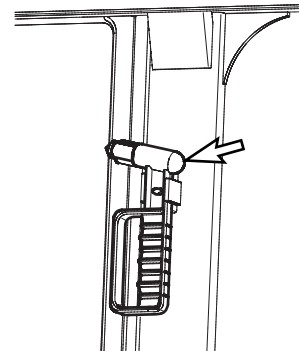

Figure 16

FG014380



WARNING

AVOID DEATH OR SERIOUS INJURY

Protect your eyes when breaking the glass.

BEFORE STARTING ENGINE

Work Site Precautions

Before starting operations, thoroughly check the area for any unusual conditions that could be dangerous.

Check the terrain and condition of the ground at the work site, and determine the best and safest method of operation.

Make sure the ground surface is as hard and horizontal as possible before carrying out operations. If there is a lot of dust and sand on the work site, spray water before starting operations.

If you need to operate on a street, protect pedestrians and cars by designating a person for work site traffic duty or by erecting fences and posting "No Entry" signs around the work site.

Erect fences, post "No Entry" signs, and take other steps to prevent people from coming close to or entering the work site. If people come close to a moving machine, they may be hit or caught by the machine, and this may lead to serious personal injury or death.

Waterlines, gas lines, phone lines and high-voltage electrical lines may be buried under the work site. Contact each utility and identify their locations. Be careful not to damage or cut any of these lines.

Check the condition of the riverbed, and the depth and flow of the water before operating in water or crossing a river. NEVER work in water that is more than the permissible water depth.

Any object in vicinity of boom could represent a potential hazard, or cause the operator to react suddenly and cause an accident. Use a spotter or signal person when working near bridges, phone lines, work site scaffolds, or other obstructions.

Minimum levels of insurance coverage, work permits or certification, physical barriers around the work site or restricted hours of operation may be mandated by governing authorities. There may also be regulations, guidelines, standards or restrictions on equipment that may have to be followed for local requirements. There may also be regulations related to performing certain kinds of work. If there is any question about whether your machine and work site complies with the applicable standards and regulations contact your local authorities and agencies.

Avoid entering soft ground. It will be difficult for the machine to escape.

Avoid operating your machine too close to the edge of cliffs, overhangs, and deep ditches. The ground may be weak in such areas.

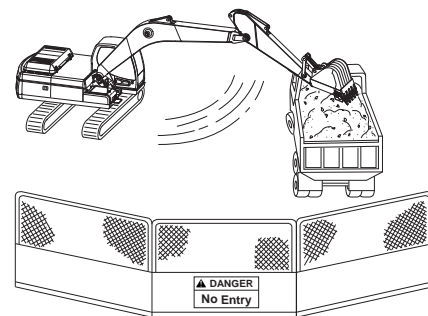

FG000400

Figure 17

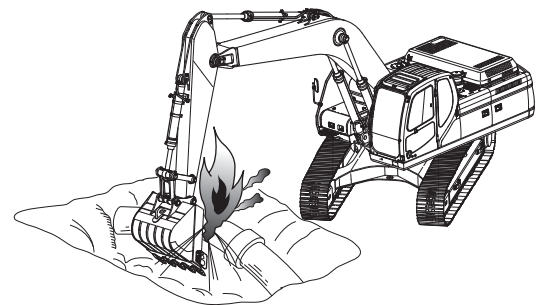

FG000363

Figure 18

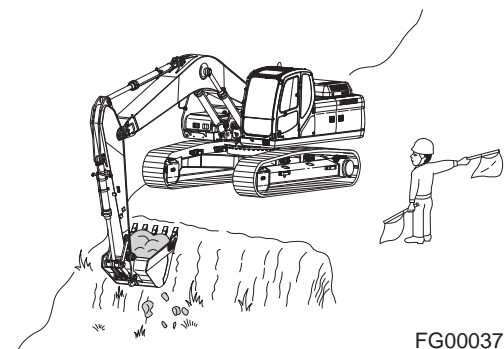

FG000372

Figure 19

If the ground collapses, the machine could fall or tip over resulting in serious injury or death.

Remember that soil after heavy rain, blasting or after earthquakes, is weakened.

Newly laid earth and the soil near ditches is typically loose. It can collapse under the weight of vibration of your machine and cause your machine to tip over.

Install the head guard (FOPS) if working in areas where there is a danger of falling rocks.

Checks Before Starting Engine

Every day before starting the engine for the first time, carry out the following checks. If these checks are not carried out properly, there is a danger of serious injury.

Remove all wood chips, leaves, grass, paper and other flammable materials accumulated in the engine compartment and around the battery. They could cause a fire. Remove any dirt from the window glass, mirrors, handrails, and steps.

Do not leave tools or spare parts laying around in the operator's cabin. The vibration of the machine when traveling or during operations can cause them to fall and damage or break the control levers or switches. They may also get caught in the gap of the control levers and cause the work equipment to malfunction or move dangerously. This may lead to unexpected accidents.

Check the coolant, fuel, and hydraulic tank oil levels, and check for clogged air cleaner and damage to the electrical wiring.

Adjust the operator's seat to a position where it is easy to operate the machine, and check the seat belt and mounts for damage and wear.

Check the operation of the gauges and the angle of the mirrors, and check that safety lever is in "LOCKED" position.

If any abnormalities are found in the above checks, carry out repairs immediately.

Engine Starting

Walk around your machine before getting in the operator's cabin. Look for evidence of leaking fluid, loose fasteners, misaligned assemblies or any other indications of possible equipment hazard.

All equipment covers and machinery safety guards must be in place, to protect against injury while the machine is being operated.

Look around the work site area for potential hazards, people or property that could be at risk while operation is in progress.

NEVER start the engine if there is any indication that maintenance or service work is in progress, or if a warning tag is attached to controls in the cabin.

A machine that has not been used recently, or is being operated in extremely cold temperatures, could require a warm-up or maintenance service before start-up.

Check gauges and monitor displays for normal operation before starting the engine. Listen for unusual noises and remain alert for other potentially hazardous conditions at the start of the work cycle.

Do not short-circuit the starting motor to start the engine. This is not only dangerous, but may also damage the machine.

When starting the engine, sound the horn as an alert.

Start and operate the machine only while seated.

Before Operating Machine

If checks are not carried out properly after starting the engine, it can result in a delay in discovering abnormalities in the machine, and this may lead to personal injury or damage to the machine.

Carry out the checks in an open area where there are no obstructions. Do not let anyone near the machine when carrying out the checks.

- Check the operating condition of the equipment, and the movement of the bucket, arm, boom, travel, and swing systems.
- Check the machine for any abnormal noise, vibration, heat, smell, or abnormality with the gauges. Check also for leakage of air, oil, and fuel.
- If any abnormality is found, repair the problem immediately. If the machine is used without repairing the problems, it may lead to unexpected injury or failure.
- Clear all personnel from directly around machine and from the area.
- Clear all obstacles from the machine's path. Beware of hazards.
- Be sure that all windows are clean. Secure the doors and the windows in the open position or in the shut position.
- Adjust the rearview mirrors for best visibility close to the machine. Make sure that horn, the travel alarm (if equipped), and all other warning devices are working properly.
- Fasten the seat belt securely.
- Warm up the engine and hydraulic oil before operating machine.
- Before moving the machine, check undercarriage position. The normal travel position is with idler wheels to the front under the cabin and the drive sprockets to the rear. When the undercarriage is in the reversed position, the travel controls must be operated in opposite directions.

Seat Belt

Check seat belt daily for correct function.

Inspect seat belt system more often if machine is exposed to severe environmental conditions or applications. Conduct the following inspections and replace seat belt system as necessary:

1. Check webbing. If system is equipped with a retractor, pull webbing completely out and inspect full length of webbing. Look for cuts, wear, fraying, dirt and stiffness.
2. Check buckle and latch for correct operation.
3. Make sure latch plate is not excessively worn, deformed or buckle is not damaged or casing is broken.
4. Check retractor web storage device (if equipped) by extending webbing and checking that it spools out and retracts correctly.
5. Check webbing in areas exposed to ultraviolet (UV) rays from sun or extreme dust or dirt. If original color of webbing in these areas is extremely faded and/or webbing is packed with dirt, webbing strength may be reduced.

NOTE: *Contact your DOOSAN distributor for seat belt system replacement parts.*



WARNING

AVOID DEATH OR SERIOUS INJURY

Failure to properly inspect and maintain seat belt and seat belt system can cause lack of operator restraint and can result in death or serious injury.

Before fastening seat belt, check that there is no problem in belt mounting bracket. If it is worn or damaged, replace seat belt. Fasten seat belt so it is not twisted.

Always wear seat belt when operating machine.

MACHINE OPERATION

When Swinging or Changing Direction of Travel

Before operating the machine or the work equipment, always observe the following precautions to prevent serious injury or death.

- Start and operate the machine only while seated.
- When changing travel direction from forward to reverse or from reverse to forward, reduce speed early and stop the machine before changing travel direction.
- Sound the horn to warn people in the area.
- Check that there is no one in the area around the machine. There are blind spots behind the machine, so if necessary, swing the upper structure to check that there is no one behind the machine before traveling in reverse.
- When operating in areas that may be hazardous or have poor visibility, designate a person to direct work site traffic.
- Ensure that no unauthorized person can come within the turning radius or direction of travel.

Be sure to observe the above precautions even if a travel alarm or mirrors are installed.

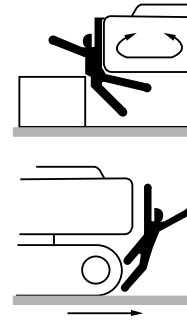

Figure 20

HAOA190L

Travel Precautions

Never turn the starting switch to "O" (OFF) position when traveling. It is dangerous if the engine stops while the machine is traveling. It will be impossible to operate the steering.

Attachment control levers should not be operated while traveling.

Do not change selected travel mode (FAST/SLOW) while traveling.

Fold in work equipment so the outer end of the boom is as close to the machine as possible, and is 40 - 50 cm (16 - 20 in) aboveground.

Never travel over obstacles or slopes that will cause the machine to tilt severely. Travel around any slope or obstacle that causes the machine to tilt 10 degrees or more to the right or left, or 30 degrees or more from front to rear.

Do not operate the steering suddenly. The work equipment may hit the ground and cause the machine to lose its balance, and this can damage the machine or structures in the area.

When traveling on rough ground, travel at low speed, and avoid sudden changes in direction.

Always keep to the permissible water depth. Permissible water depth is to the centerline of the upper track rollers.

When traveling over bridges or structures on private land, check first that bridge or structure can withstand the weight of the machine. When traveling on public roads, check with the local authorities and follow their instructions.

TRAVEL POSTURE

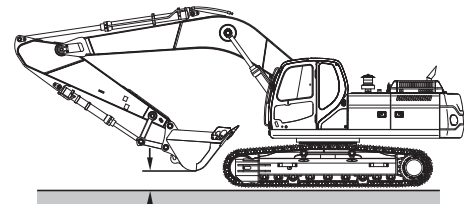

40 ~ 50 cm (16 ~ 20 in.)

INCORRECT

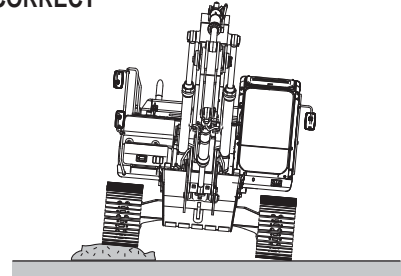

FG000349

Figure 21

Traveling on Slopes

Never jump onto a machine that is running away to stop it. There is a danger of serious injury.

Traveling on slopes could result in the machine tipping over or slipping.

On hills, banks or slopes, carry the bucket approximately 20 - 30 cm (8 - 12 in) above the ground. In case of an emergency, quickly lower the bucket to the ground to help stop the machine.

Do not travel on grass, fallen leaves, or wet steel plates. Even slight slopes can cause the machine to slip to the side, so travel at low speed and make sure that the machine is always traveling directly up or down the slope.

Avoid changing travel direction on a slope. This could result in tipping or sideslipping of the machine.

When possible, operate the machine up slopes and downslopes. Avoid operating the machine across the slope, when possible.

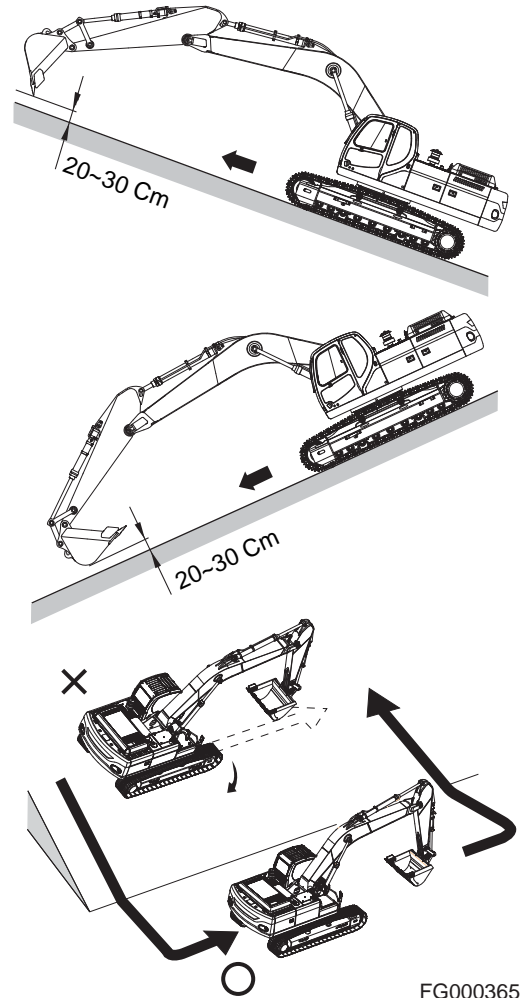

Figure 22

FG000365

Prohibited Operations

Do not dig the work face under an overhang. This can cause the overhang to collapse and fall on top of the machine.

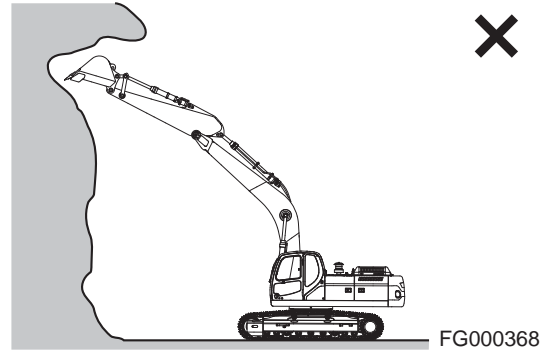

Figure 23

Do not carry out deep digging under the front of the machine. The ground under the machine may collapse and cause the machine to fall.

Working heavy loads over loose, soft ground or uneven, broken terrain can cause dangerous side load conditions and possible tip over and injury. Travel without a load or a balanced load may also be hazardous.

Never rely on lift jacks or other inadequate supports when work is being done. Block tracks fore and aft to prevent any movement.

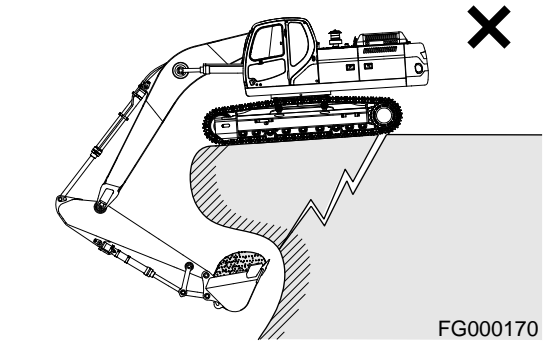

Figure 24

When using the machine, to prevent accidents caused by damage to the work equipment and overturning because of an excessive load, do not use the machine in excess of its ability (in terms of the maximum load and stability determined by the structure of the machine).

When working at the edge of an excavation or on a road shoulder, the machine could tip over, possibly resulting in serious injury or death. Investigate the configuration and ground conditions of the work site beforehand to prevent the machine from falling and to prevent the ground, stockpiles, or banks from collapsing.

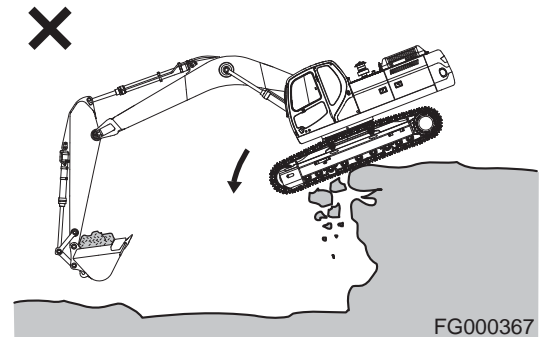

Figure 25

Precautions for Operation

Be careful not to mistakenly travel too close to the edge of a cliff.

Use the machine only for its main purpose. Using it for other purposes will cause failures.

To ensure a good view, always do the following:

- When working in dark areas, attach working lights and front lights to the machine. If necessary, set up lighting at the work site.
- Stop operations when the visibility is poor, such as in fog, mist, snow, and rain. Wait for the visibility to improve to a level which causes no problems for the operation.

To avoid hitting the work equipment, always do the following:

- When working in tunnels, on bridges, under electrical wires, or when parking the machine or carrying out other operations in places with limited height, be careful not to hit the bucket or other parts.
- To prevent collisions, operate the machine at a safe speed when working in confined spaces, indoors, or in crowded areas.
- Do not pass the bucket over the heads of workers or over the operator's cabin of dump truck.



Figure 26

Avoid High-voltage Cables

Serious injury or death can result from contact or proximity to high-voltage electrical lines. The bucket does not have to make physical contact with power lines for current to be transmitted.

Use a spotter and hand signals to stay away from power lines not clearly visible to the operator.

| Voltage | Minimum Safe Distance |
|----------|-----------------------|
| 6.6 kV | 3 m (9' 10") |
| 33.0 kV | 4 m (13' 1") |
| 66.0 kV | 5 m (16' 5") |
| 154.0 kV | 8 m (26' 3") |
| 275.0 kV | 10 m (32' 10") |

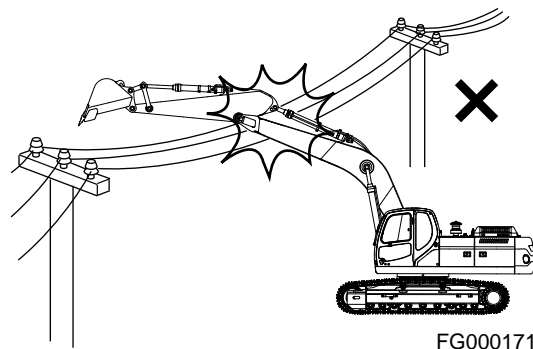

Figure 27

Use these minimum distances as a guideline only. Depending upon the voltage in the line and atmospheric conditions, strong current shocks can occur with the boom or bucket as faraway as 4 - 6 m (13 - 20 ft.) from the power line. Very high voltage and rainy weather could further decrease that safety margin.

NOTE: Before starting any operation near power lines (either aboveground or buried cable type), you should always contact the power utility company directly and work out a safety plan with them.

Roll Over Protective Structure (ROPS)

The operator's cabin is a ROPS certified structure for protecting the seat-belted operator. It absorbs the impact energy of a rollover impact. Do not allow machine weight (mass) to exceed certified value on certification plate. If weight is exceeded, the ROPS structure will not be able to fulfill its safety function.

Do not increase machine weight beyond certified value by modifying machine or by installing attachments on machine. If weight limit of protective equipment is exceeded, protective equipment will not be able to protect operator, and operator may suffer injury or death. Always observe the following:

- This machine is equipped with a protective structure. Do not remove protective structure and carry out operations without it.
- Never modify the operator's cabin by welding, grinding, drilling holes or adding attachments unless instructed by DOOSAN. Changes to the cabin can cause loss of operator protection from rollover and falling objects, and operator may suffer serious injury or death.
- When protective structure is damaged or deformed by falling objects or by rolling over, its strength will be reduced and it will not be able to properly fulfill its function. In these cases, always contact your DOOSAN distributor for advice. Never repair a ROPS cabin.
- Always wear your seat belt when operating machine.

ROPS Certification

This DOOSAN excavator has an operator's cabin that meets ROPS requirements. The seat belt must be worn for rollover protection.

The ROPS certification plate (Figure 28) is found on the left side of the cabin on most models. It may vary slightly in its location on some models.

Check the ROPS cabin, mounting, and hardware for damage.

Never modify the ROPS cabin. Replace the cabin and hardware if damaged. See your DOOSAN dealer for parts.

ROPS – Roll-over Protective Structure complies with ISO 12117-2:2008, EN 13531: 2001.

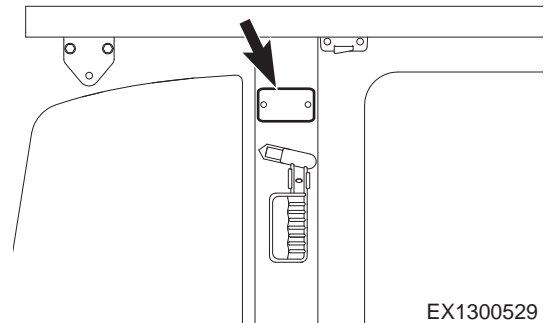

Figure 28



WARNING

AVOID DEATH OR SERIOUS INJURY

Never modify the operator cabin by welding, grinding, drilling holes or adding attachments unless instructed by DOOSAN. Changes to the cabin can cause loss of operator protection from rollover and falling objects, and result in serious injury or death.

Protecting Cabin from Falling Object (Optional)

In a work site where falling objects or flying objects are expected, be sure to install adequate protective devices for covering the cabin.

When using a breaker, be sure to install the front window protection guard (1, Figure 29).

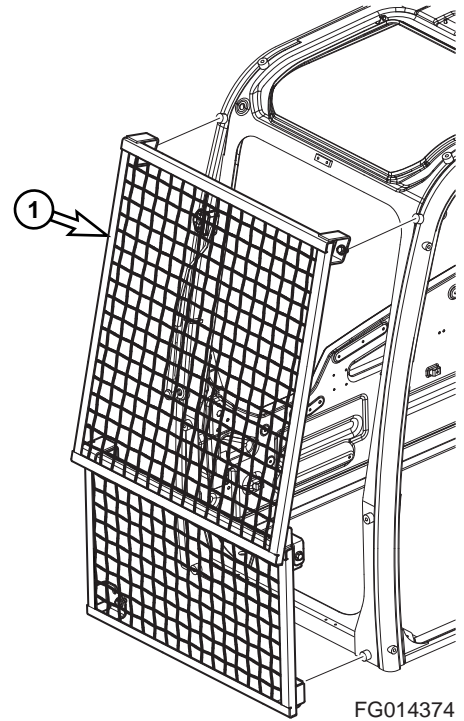

FG014374

Figure 29

In a work site where falling rocks can cause damage and possibly crush personnel, or in a mining operation, be sure to install the falling object protective structure (2, Figure 30).

Be sure to install any other additional protective structures required for work site conditions.

When the falling object protective structure is installed, and the front window needs to be cleaned, loosen the bolts marked with an arrow. Be sure to tighten bolts when done.

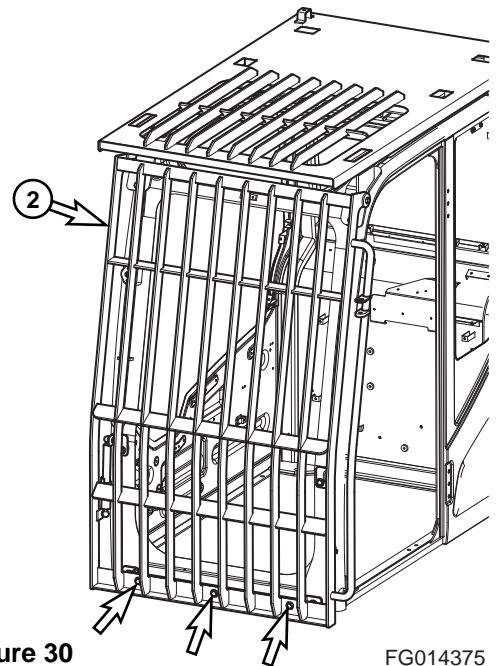

FG014375

Figure 30

Operate Carefully on Snow, Ice and in Very Cold Temperatures

In icy cold weather avoid sudden travel movements and stay away from even slight slopes. The machine could skid off to one side very easily.

Snow accumulation could hide or obscure potential hazards. Use care while operating or while using the machine to clear snow.

Warming up the engine for a short period may be necessary, to avoid operating with sluggish or reduced working capacity. The jolting shocks and impact loads caused by bumping or bottoming the boom or attachment are more likely to cause severe stress in very cold temperatures. Reducing work cycle rate and workload may be necessary.

When the temperature rises, frozen road surfaces become soft, and machine travel becomes unstable.

In cold weather, do not touch metal surfaces with your bare hands. If you touch a metal surface in extremely cold weather, your skin may freeze to the metal surface.

Operations on Slopes

When working on slopes, there is a danger that the machine may lose its balance and turn over, when swinging, or when work equipment is operated. Always carry out these operations carefully.

Do not swing the work equipment from the uphill side to the downhill side when the bucket is loaded. This operation is dangerous.

If the machine has to be used on a slope, pile the soil to make a platform that will keep the machine as horizontal as possible.

In addition, lower the bucket as far as possible, keep it pulled into the front, and keep the swing speed as low as possible.

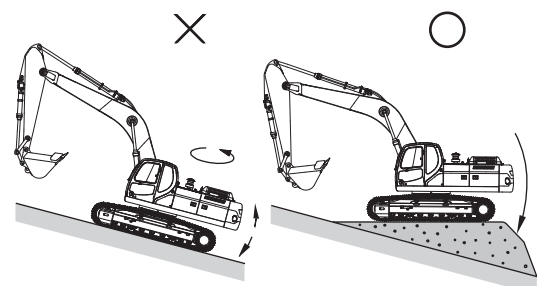

FG000212

Figure 31

Parking Machine

Avoid making sudden stops, or parking the machine wherever it happens to be at the end of the workday. Plan so the excavator will be on firm and level ground away from traffic and away from high walls, cliff edges and any area of potential water accumulation or runoff. If parking on inclines is unavoidable, block the crawler tracks to prevent movement. Lower the bucket or other working attachment completely to the ground, or to an overnight support saddle. There must be no possibility of unintended or accidental movement.

When parking on public roads, provide fences, signs, flags, or lights, and put up any other necessary signs to ensure that passing traffic can see the machine clearly. Park the machine so the machine, flags, and fences do not obstruct traffic.

After the front attachment has been lowered to an overnight storage position and all switches and operating controls are in the "OFF" position, the safety lock lever must be set to "LOCKED" position. This will disable all pilot circuit control functions.

Always close the door of the operator's cabin.

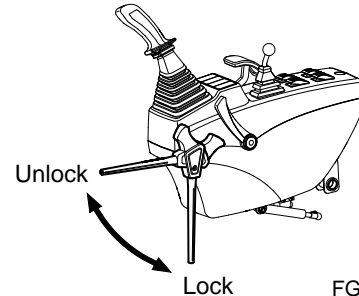
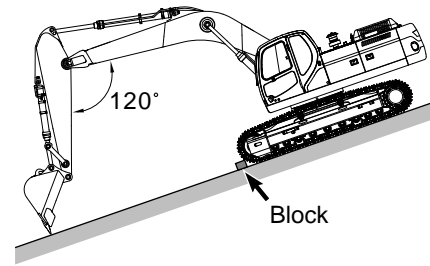

Figure 32

FG015009

Never Let Anyone Ride on Attachment

Never let anyone ride on any work attachment, such as the bucket, crusher, grapple, or clamshell (grab bucket). There is a potential danger of the person falling and suffering serious injury.

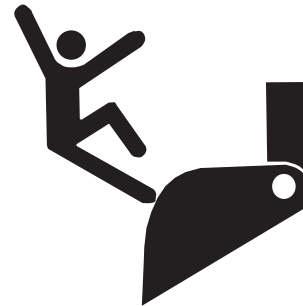

Figure 33

ARO1310L

MAINTENANCE

Warning Tag

Alert others that service or maintenance is being performed and tag operator's cabin controls – and other machine areas if required – with a warning notice. OSHA mandated control lever lockout can be made with any OSHA certified lockout device and a length of chain or cable to keep the safety lever in the fully lowered, nonnative position.

Warning tags, for controls are available from DOOSAN distributors.

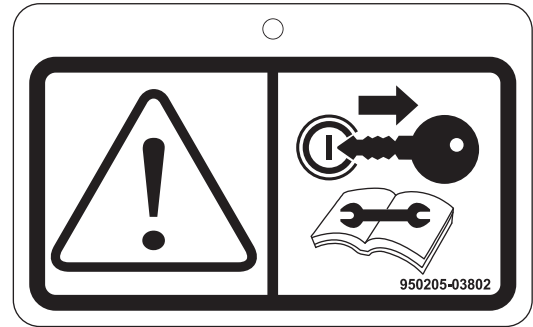

Figure 34

EX1301177

Clean Before Inspection or Maintenance

Clean the machine before carrying out inspection and maintenance. This prevents dirt from getting into the machine and ensures safety during maintenance.

If inspection and maintenance are carried out when the machine is dirty, it will become more difficult to locate the problems, and there is a danger that you may get dirt or mud in your eyes or that you may slip and injure yourself.

When washing the machine, do the following:

- Wear shoes with nonslip soles to prevent yourself from slipping and falling on wet places.
- Wear safety glasses and protective clothing when washing the machine with high-pressure steam.
- Take action to prevent touching high-pressure water and cutting your skin or having mud fly into your eyes.
- Do not spray water directly on electrical components (sensors, connector). If water gets into the electrical system, there is a danger that it will cause defective operation and malfunction.

Pick up any tools or hammers that are laying in the workplace. Wipe up any grease or oil or any other slippery substances, and clean the area to make it possible to carry out the operation in safety. If the workplace is left untidy, you may trip or slip and suffer injury.

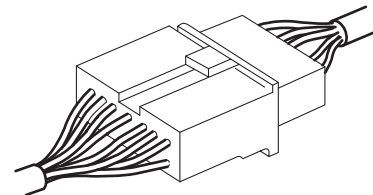
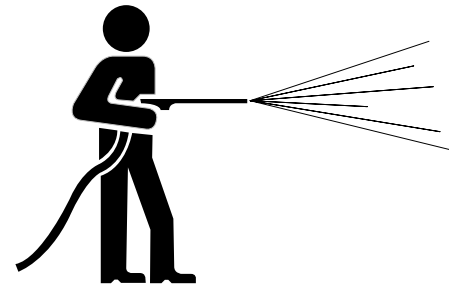

Figure 35

ARO1330L

Proper Tools

Use only tools suited to the task. Using damaged, low quality, faulty, or makeshift tools could cause personal injury. There is a danger that pieces from, chisels with crushed heads, or hammers, may get into your eyes and cause blindness.

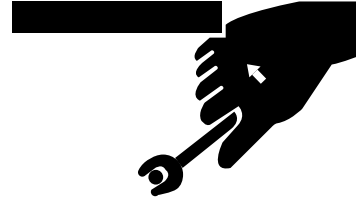

Figure 36

HDO1037L

Use of Lighting

When checking fuel, oil, battery electrolyte, or window washing fluid, always use lighting with antiexplosion specifications. If such lighting equipment is not used, there is a danger of an explosion.

If work is carried out in dark places without using lighting, it may lead to injury, so always use proper lighting.

Even if the place is dark, never use a lighter or flame instead of lighting. There is a danger of fire. There is also a danger that battery gas may catch fire and cause an explosion.



Figure 37

HDO1040L

Fire Prevention and Explosion Prevention

All fuels, most lubricants and some coolant mixtures are flammable. Leaking fuel or fuel that is spilled onto hot surfaces or onto electrical components can cause a fire.

Store all fuels and all lubricants in properly marked containers and away from all unauthorized persons.

Store oily rags and other flammable material in a protective container.

Do not smoke while you refuel the machine or while you are in a refueling area.

Do not smoke in battery charging areas or in areas that contain flammable material.

Clean all electrical connections and tighten all electrical connections. Check the electrical wires daily for wires that are loose or frayed. Tighten all loose electrical wires before you operate the machine. Repair all frayed electrical wires before you operate the machine.

Remove all flammable materials before they accumulate on the machine.

Do not weld on pipes or on tubes that contain flammable fluids. Do not flame cut on pipes or on tubes that contain flammable fluids. Before you weld on pipes or on tubes or before you flame cut on pipes or on tubes, clean the pipes or tubes thoroughly with a nonflammable solvent.



Figure 38

HDO1015I

Burn Prevention

When checking the radiator coolant level, stop engine, let the engine and radiator cool down, then check the coolant recovery tank. If the coolant level in the coolant recovery tank is near the upper limit, there is enough coolant in the radiator.

Loosen the radiator cap gradually to release the internal pressure before removing the radiator cap.

If the coolant level in the coolant recovery tank is below the lower limit, add coolant.

Cooling system conditioner contains alkali. Alkali can cause personal injury. Do not allow alkali to contact the skin, the eyes, or the mouth.

Allow cooling system components to cool before you drain the cooling system.

Hot oil and hot components can cause personal injury. Do not allow hot oil or hot components to contact the skin.

Remove hydraulic tank filter plug only after the engine has been stopped. Make sure that hydraulic tank filter plug is cool before you remove it with your bare hand. Remove hydraulic tank filter plug slowly to relieve pressure.

Relieve all pressure in the hydraulic oil system, in the fuel system, or in the cooling system before you disconnect any lines, fittings, or related items.

Batteries give off flammable fumes that can explode.

Do not smoke while you are checking the battery's electrolyte levels.

Electrolyte is an acid. Electrolyte can cause personal injury. Do not allow electrolyte to contact the skin or the eyes.

Always wear protective glasses when you work on batteries.

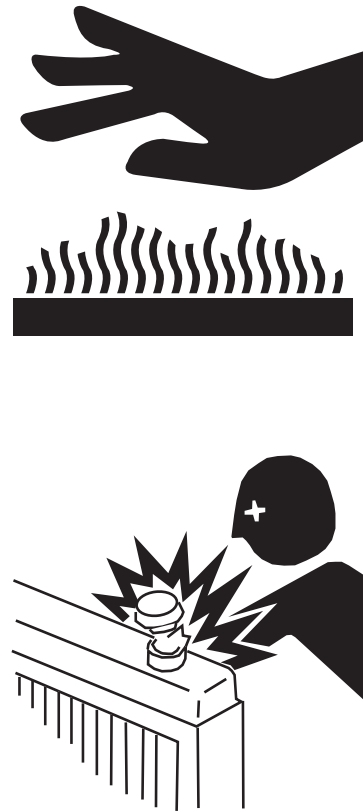

Figure 39

haae2090

IMPORTANT

When disconnecting or connecting connectors between ECU and engine, or connector between ECU and the machine, always disconnect the battery to prevent damage to ECU.

If you do not follow this procedure, the ECU will be damaged and/or the engine will not operate properly.

When performing welding repairs, perform welding in a properly equipped place. Repairs must be performed by a qualified welder. Welding operations, can create potential hazards, including generation of gas, fire, or electric shock. Never let an unqualified welder do welding.

A qualified welder must do the following:

- To prevent battery explosion, turn battery disconnect switch to "OFF" position.
- Disconnect the connector between ECU and machine, and the connector between ECU and engine.
- To prevent generation of gas, remove paint from location of the weld.
- If hydraulic equipment, piping or component ports close to them are heated, a flammable gas or mist could result in an explosion or fire. To prevent this, protect and insulate components from excessive heat.
- Do not weld on pipes or on tubes that contain flammable fluids. Do not flame cut pipes or tubes that contain flammable fluids. Before welding on pipes or tubes, or before flaming cut pipes or tubes, clean them thoroughly with a nonflammable solvent. Make sure pressure inside pipes or tubes does not cause a rupture of the component parts.
- If heat is applied directly to rubber hoses or piping under pressure, they may suddenly break, so cover and insulate them with a fireproof covering.
- Wear protective clothing.
- Make sure there is good ventilation.
- Remove all flammable objects and make sure a fire extinguisher is available.

Treatment for Electrical Welding to the Body Structure

To prevent damage to ECU by electrical welding, please observe the following procedures:

1. Open the door of the battery cover.
2. Detach the cover after loosening the bolts on the battery.
3. Detach the positive and negative terminal cables from the battery.
4. Detach the undercover, and after that detach the connector (1) from the ECU that are installed at the engine.
5. Proceed with welding.
6. After welding, carefully reassemble the connector.
7. Connect the battery terminal cables.
8. Reassemble the undercover under the engine.
9. Reassemble the cover over the battery.
10. Close the cover of the battery.

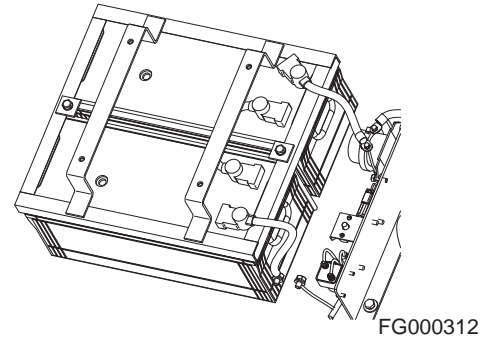

Figure 40

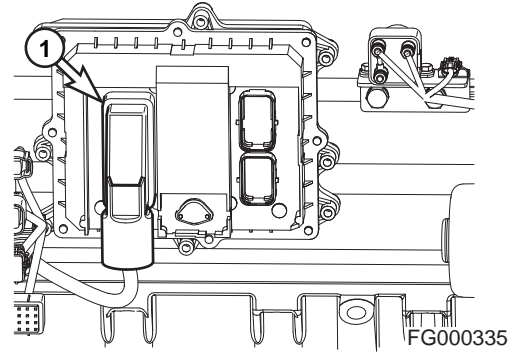

Figure 41

Warning for Counterweight and Front Attachment Removal



DANGER

AVOID DEATH

DOOSAN warns any user, that removal of the counterweight from the machine, front attachment or any other part, may affect the stability of the machine. This could cause unexpected movement, resulting in death or serious injuries. DOOSAN is not liable for any misuse.

Never remove counterweight or front attachment unless the upper structure is in-line with the lower structure.

Never rotate the upper structure once the counterweight or front attachment has been removed.

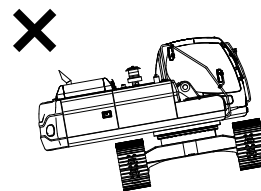
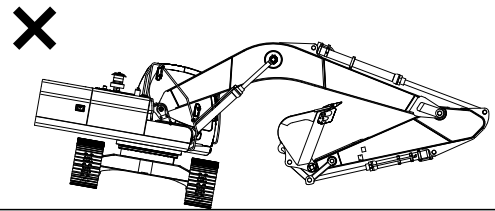

FG000371

Figure 42

Precautions for Removal, Installation, and Storage of Attachments

Before starting removal and installation of attachments, decide on the team leader.

Do not allow anyone except the authorized workers close to the machine or attachment.

Place attachments that have been removed from the machine in a safe place so they do not fall. Put up a fence around the attachments and take other measures to prevent unauthorized persons from entering.



Figure 43

HDO1041L

Precautions When Working on Machine

When carrying out maintenance operations on the machine, keep area around your feet clean and tidy to prevent falls. Always do the following:

- Do not spill oil or grease.
- Do not leave tools laying about.
- Watch your step when walking.

Never jump down from the machine. When getting on or off the machine, use the steps and handrails, and maintain a three-point contact (both feet and one hand or both hands and one foot) to support yourself securely.

If the job requires it, wear protective clothing.

To prevent injury from slipping or falling, when working on the hood or covers, never use any area except the area equipped with nonslip pads.



Figure 44

ARO1380L

Lock Inspection Covers

When carrying out maintenance with the inspection cover open, lock the cover securely in position with the lock bar.

If maintenance work is carried out with the inspection cover open but not locked, there is a danger that it may suddenly close and cause injury if there is a gust of wind.

Prevention of Crushing and Cutting

You should always have at least two people working together if the engine must be run during service. One person needs to remain in the operator's seat, ready to work the controls or stop the machine and shut off the engine.

Unless you are instructed otherwise, never attempt adjustments while the machine is moving or while the engine is running.

Stay clear of all rotating parts and moving parts.

Keep objects away from moving fan blades. The fan blades will throw objects and the fan blades can cut objects.

Do not use a wire rope cable that is kinked or flayed. Wear gloves when you handle a wire rope cable.

When you strike a retainer pin, the retainer pin might fly out. The loose retainer pin can injure personnel. Make sure that area is clear of people when you strike a retainer pin. To avoid injury to your eyes, wear protective glasses when you strike a retainer pin.

Track Tension Adjustments Require Caution

Never turn out the track tension grease valve. To release pressure from the crawler frame track tension assembly, you should NEVER attempt to disassemble the track adjuster or attempt to remove grease fitting or valve assembly.

Keep your face and body away from the valve. Refer to the track adjustment procedure in the Operator and Maintenance Manual or Shop Manual.

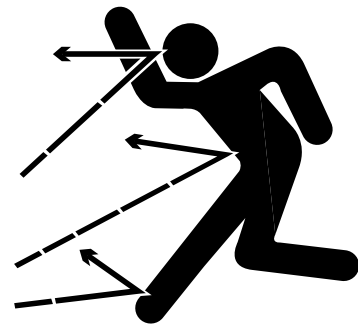

Figure 45

HAOA110L

Supports and Blocking for Work Equipment

Do not allow weight or equipment loads to remain suspended.

Lower everything to the ground before leaving the operator's seat.

Do not use hollow, cracked or unsteady wobbling supports.

Do not work under any equipment supported only by a lifting jack.

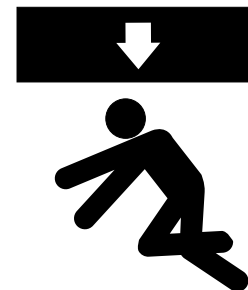

Figure 46

HDO1042L

Action When Abnormality Is Found During Inspection

If any abnormality is found during inspection, always carry out repairs. In particular, if the machine is used when there are still problems with the brake or work equipment systems, it may lead to serious injury.

If necessary depending on the type of failure, please contact your DOOSAN distributor for repairs.

Precautions with High-pressure Lines, Tubes and Hoses

When inspecting or replacing high-pressure piping or hoses, check to verify that pressure has been released from the circuit. Failure to release the pressure may lead to serious injury. Always do the following:

- Wear protective glasses and leather gloves.
- Fluid leaks from hydraulic hoses or pressurized components can be difficult to see but pressurized oil has enough force to pierce the skin and cause serious injury. Always use a piece of wood or cardboard to check for suspected hydraulic leaks. Never use your hands or expose your fingers.
- Do not bend high-pressure lines. Do not strike high-pressure lines. Do not install lines, tubes or hoses that are bent or damaged.
- Make sure that all clamps, guards and heat shields are installed correctly to prevent vibration, rubbing against other parts, and excessive heat during operation.
 - If any of the following conditions are found, replace the part:
 - Damage or leakage from hose end.
 - Wear, damage, cutting of covering, or exposure of strengthening wire layer.
 - Cover portion is swollen in places.
 - There is twisting or crushing at movable parts of hose.
 - Foreign material is embedded in the covering.
 - Hose end is deformed.

NOTE: Refer to "Hose In-service Lifetime Limit (European Standard ISO 8331 and EN982 CEN)" on page 4-64, for additional European regulations.

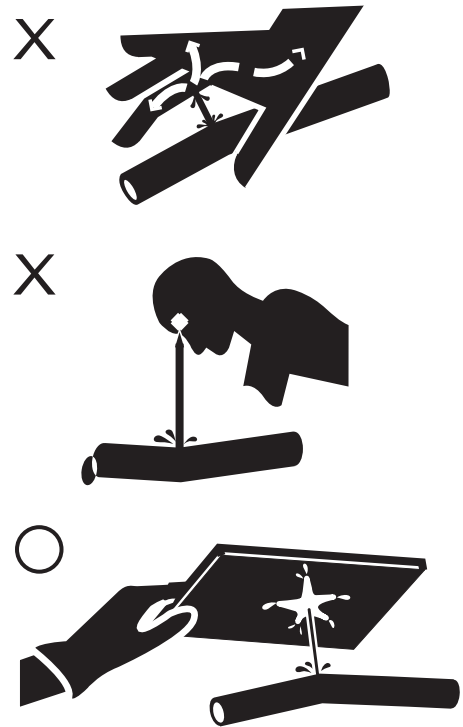

HDO1045I

Figure 47

Waste Materials

Physical contact with used motor oil may pose a health risk. Wipe oil from your hands promptly and wash off any remaining residue.

Used motor oil is an environmental contaminant and may only be disposed of at approved collection facilities. To prevent pollution of the environment, always do the following:

- Never dump waste oil in a sewer system, rivers, etc.
- Always put oil drained from your machine in containers. Never drain oil directly onto the ground.
- Obey appropriate laws and regulations when disposing of harmful materials such as oil, fuel, solvent, filters, and batteries.

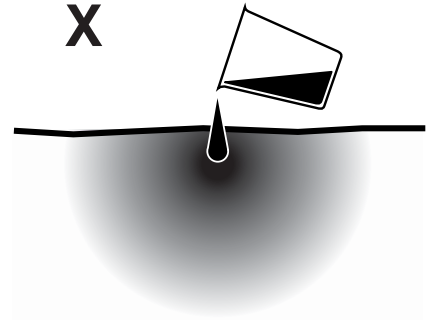

HAOA470L

Figure 48

BATTERY

Battery Hazard Prevention

Battery electrolyte contains diluted sulfuric acid and batteries generate hydrogen gas. Hydrogen gas is highly explosive, and mistakes in handling them can cause serious injury or fire. To prevent problems, always do the following:

- Do not smoke or bring any flame near the battery.
- When working with batteries, ALWAYS wear safety glasses and rubber gloves.
- If you spill battery electrolyte on yourself or your clothes, immediately flush the area with water.
- If battery electrolyte gets into your eyes, flush them immediately with large quantities of water and see a doctor at once.
- If you accidentally drink battery electrolyte, drink a large quantity of water or milk, raw egg or vegetable oil. Call a doctor or poison prevention center immediately.
- When cleaning the top surface of the battery, wipe it with a clean, damp cloth. Never use gasoline, thinner, or any other organic solvent or detergent.
- Tighten the battery caps securely.
- If the battery electrolyte is frozen, do not charge the battery or start the engine with power from another source. There is a danger that battery may catch fire.
- When charging the battery or starting with power from another source, let the battery electrolyte melt and check that there is no leakage of battery electrolyte before starting the operation.
- Always remove battery from the machine before charging.

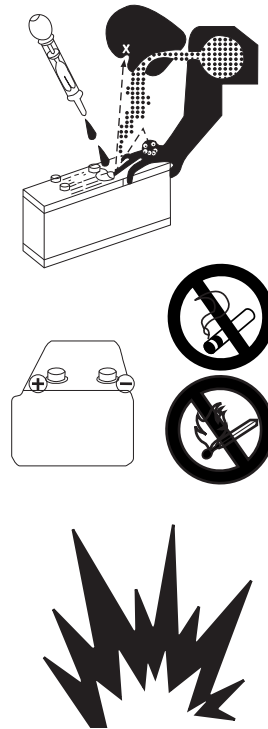

Figure 49

HAAE2100

Boost Starting or Charging Engine Batteries

If any mistake is made in the method of connecting the booster cables, it can cause an explosion or fire. Always do the following:

- Turn off all electrical equipment before connecting leads to the battery. This includes electrical switches on the battery charger or boost starting equipment.
- When boost starting from another machine or vehicle do not allow the two machines to touch. Wear safety glasses or goggles while required battery connections are made.
- 24 volt battery units consisting of two series connected twelve volt batteries have a cable connecting one positive terminal on one of the 12 volt batteries to a negative terminal on the other battery. Booster or charger cable connections must be made between the nonseries connected positive terminals and between the negative terminal of the booster battery and the metal frame of the machine being boosted or charged. Refer to the procedure and illustration in "Starting Engine With a Booster Cable" on page 3-7 of this manual.
- Connect positive cable first when installing cables and disconnect the negative cable first when removing them. The final cable connection, at the metal frame of the machine being charged or boost started, must be as faraway from the batteries as possible.

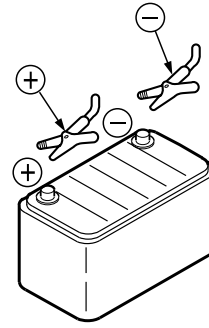

Figure 50

HAOA310L

TOWING

Precautions When Towing

If any mistake is made in the method of selecting or inspecting the towing wire or in the method of towing, it may lead to serious personal injury. Always do the following:

- Always use the method of towing given in this Operation and Maintenance Manual. Do not use any other method.
- Use leather gloves when handling the wire rope.
- When carrying out the preparation work for towing with two or more workers, determine the signals to use and follow these signals correctly.
- Always fit the towing rope to the left and right hooks and secure in position.
- If the engine on the problem machine will not start or there is a failure in the brake system, always contact your DOOSAN distributor.
- Never go between the towing machine and the towed machine during the towing operation.
- It is dangerous to carry out towing on slopes, so select a place where the slope is gradual. If there is no place where the slope is gradual, carry out operations to reduce the angle of the slope before starting the towing operation.
- When towing a problem machine, always use a wire rope with a sufficient towing capacity.
- Do not use a frayed, kinked rope or a rope with any loss of diameter.
- Do not use the lightweight towing hook for towing another machine.

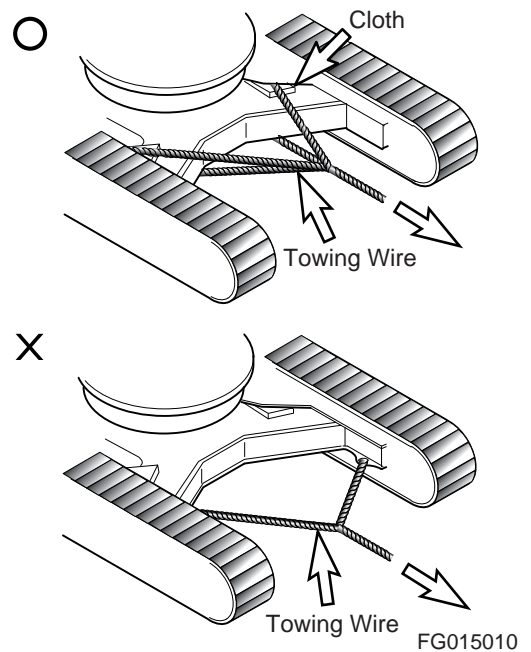

Figure 51

SHIPPING AND TRANSPORTATION

Obey State and Local Over-the-Road Regulations

Check state and local restrictions regarding weight, width and length of a load before making any other preparation for transport.

The hauling vehicle, trailer and load must all be in compliance with local regulations governing the intended shipping route.

Partial disassembly or teardown of the excavator may be necessary to meet travel restrictions or particular conditions at the work site. See the Shop Manual for information on partial disassembly.

Refer to the Transportation and Shipping section of this Operation and Maintenance Manual for information on loading, unloading and towing.

EXCAVATOR RATED LIFT CAPACITY TABLES



WARNING

AVOID DEATH OR SERIOUS INJURY

Let everybody be away from the boom cylinder. While lifting operation, boom, arm, bucket hoses might burst and then high-pressure oil will be ejected at high-speed.

If that failure mode takes place, handling weight or front structure might fall by its gravity to the ground to cause fatal injury to the person.

When changing the hoses record the part numbers of the hoses to factory log book.

Do the service job under the company's serviceman.

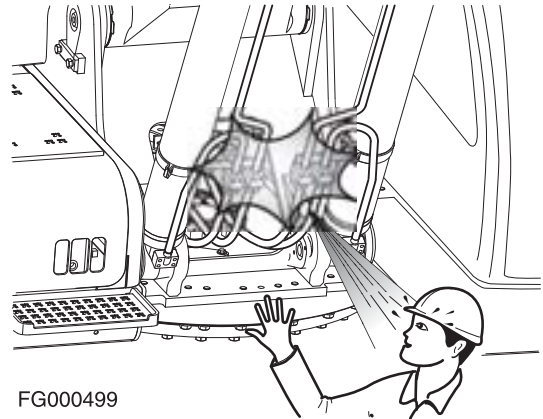

FG000499

Figure 52



WARNING

AVOID DEATH OR SERIOUS INJURY

All rated lift capacities are based on the machine and the load both remaining level at all times. **DO NOT EXCEED THE RATED LIFT CAPACITY.** Lifting loads greater than those shown in the rated capacity tables can cause catastrophic equipment failure and/or structural collapse of the machine.

To operate safely the excavator must be on a firm, level and uniformly supporting surface. The operator is expected to make due allowance for all specific work site and lift related conditions, and respond to changes in those conditions that could pose a hazard. The following could all cause hazardous conditions and accidents or injuries:

- Soft or uneven ground.
- Unlevel terrain.
- Side loads.
- Modifications or poor maintenance of the excavator.
- Failure to lift squarely over the end or over the side of the machine.

When a load is in the air, the operator must remain alert.

- Avoid side loads that may be caused by uneven slings, traveling with the load or swinging too quickly.
- The load can become unbalanced if the hook line is twisted and starts to rotate. If the surface area of the load is large enough, wind gusts can create side loads.
- Keep the bucket hook point directly over the load. Tag lines on opposite sides of the load can help maintain greater stability against side loads and wind gusts.

Avoid traveling with a suspended load. Before swinging (or if required, traveling), bring the load into an arm position (radius and height) that has a safer weight capacity rating and adequate movement clearance. The operator and all work site personnel must be thoroughly familiar with safety instructions and procedures within this Operation and Maintenance Manual.

The following weight loads are in compliance with ISO 10567 and ISO applicable, recommended standards for hydraulic excavators performing lifting operation on a firm supporting surface. An asterisk (*) next to the lift rating indicates rated load does not exceed 87% of hydraulic capacity. All other ratings have been determined not to exceed 75% of tipping capacity.

Do not attempt to lift or hold any load that exceeds rated load capacity at the specified distances (from the machine's rotation centerline and height - see "lift radius" and "lift height" in the reference drawing, Figure 53).

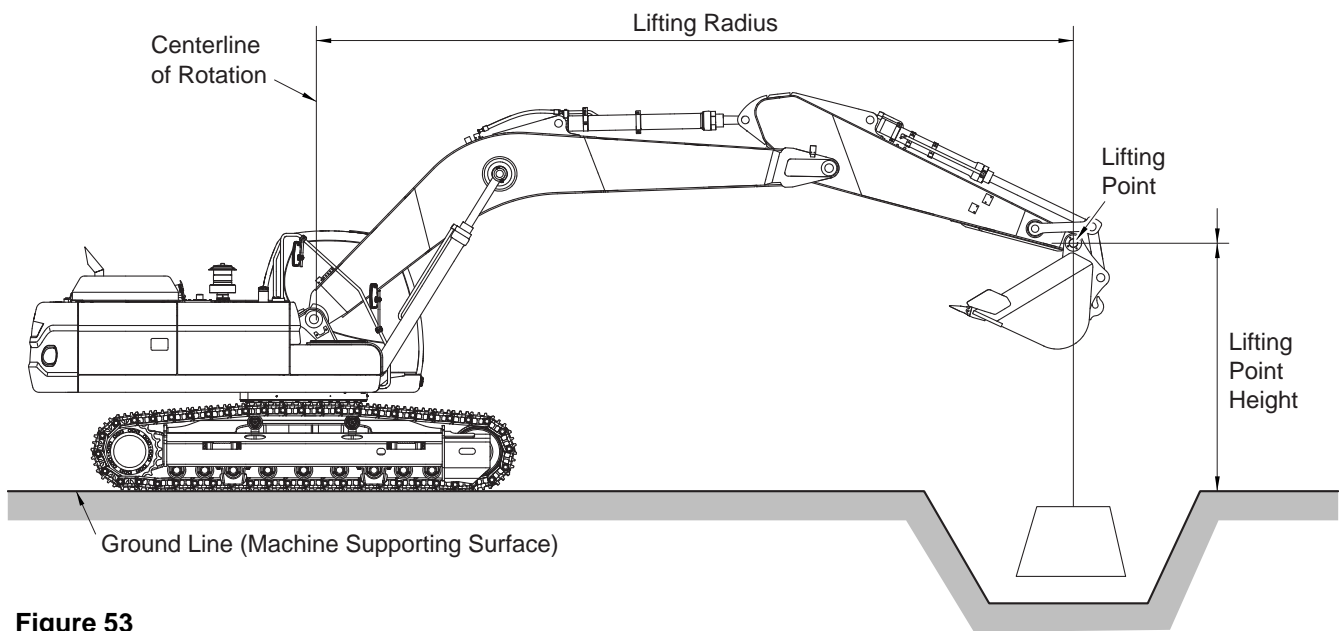

Figure 53

FG019262



The weight of slings and any auxiliary lifting device (and/or the weight difference of any attachment heavier than standard configuration) must be deducted from the rated lift capacity to determine allowable net lifting load. The lift point must be on the end of the arm, as shown in Figure 53.

IMPORTANT

Select the Digging Mode switch on the Instrument Panel before using the excavator for lifting work. Engine and hydraulic oil should both be fully warmed up to operating temperature before starting a lift.

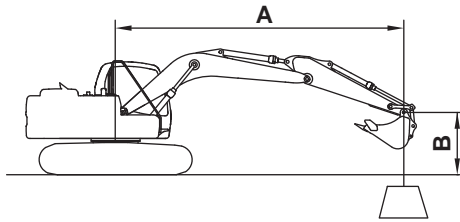
DX140LCR (Boom 4.6 m, Arm 3.0 m, Bucket 0.39 m³)

















- Boom : 4.6 m (15' 0")
- Arm : 3.0 m (9' 10")
- Bucket : 0.39 m³ (0.51 yd³)
- Shoe : 600 mm (2')
- UNIT : 1000 kg (1000 lb)
-  : Rated lift capacity - over front
-  : Rated lift capacity - over side

FG019263

Figure 54









Metric

Unit: 1,000 kg

| A (m) \ B (m) | 2 | | 3 | | 4 | | 5 | | 6 | | 7 | | Max. Reach | | | |
|---------------|---|---|---|---|---|---|---|---|---|--|---|---|---|---|--------|------|
| |  |  |  |  |  |  |  |  |  |  |  |  |  |  | Reach | |
| 8 | | | | | | | | | | | | | | 2.19 * | 2.19 * | 3.49 |
| 7 | | | | | 2.71 * | 2.71 * | | | | | | | | 1.76 * | 1.76 * | 4.97 |
| 6 | | | | | 2.81 * | 2.81 * | 2.62 * | 2.62 * | | | | | | 1.59 * | 1.59 * | 5.91 |
| 5 | | | | | 2.88 * | 2.88 * | 2.91 * | 2.91 * | 2.44 * | 2.24 | | | | 1.51 * | 1.51 * | 6.57 |
| 4 | | | 2.97 * | 2.97 * | 3.28 * | 3.28 * | 3.30 * | 3.06 | 2.95 * | 2.21 | 1.53 * | 1.53 * | 1.50 * | 1.50 * | 7.01 | |
| 3 | | | 5.35 * | 5.35 * | 4.49 * | 4.28 | 3.94 * | 2.95 | 3.5 | 2.15 | 2.30 * | 1.61 | 1.53 * | 1.48 | 7.29 | |
| 2 | | | 7.52 * | 6.43 | 5.51 * | 4.04 | 4.52 * | 2.82 | 3.42 | 2.08 | 2.63 | 1.58 | 1.61 * | 1.41 | 7.43 | |
| 1 | | | 9.15 * | 5.97 | 6.43 * | 3.81 | 4.49 | 2.7 | 3.34 | 2.01 | 2.59 | 1.54 | 1.73 * | 1.38 | 7.42 | |
| 0 | | | 8.30 * | 5.72 | 6.34 | 3.65 | 4.38 | 2.59 | 3.27 | 1.95 | 2.55 | 1.51 | 1.93 * | 1.41 | 7.28 | |
| -1 | 5.29 * | 5.29 * | 9.10 * | 5.63 | 6.23 | 3.56 | 4.3 | 2.53 | 3.23 | 1.91 | | | 2.22 * | 1.5 | 6.99 | |
| -2 | 7.05 * | 7.05 * | 9.57 * | 5.62 | 6.2 | 3.53 | 4.28 | 2.51 | 3.21 | 1.9 | | | 2.70 * | 1.67 | 6.53 | |
| -3 | 9.30 * | 9.30 * | 8.65 * | 5.69 | 6.23 | 3.56 | 4.3 | 2.53 | | | | | 3.37 | 2 | 5.86 | |
| -4 | 9.74 * | 9.74 * | 7.08 * | 5.83 | 5.34 * | 3.65 | | | | | | | 3.96 * | 2.69 | 4.90 | |

Feet



Unit: 1,000 lb

| A (ft) \ B (ft) | 10 | | 15 | | 20 | | Max. Reach | | |
|-----------------|---|---|---|---|---|---|---|---|-------|
| |  |  |  |  |  |  |  |  | Reach |
| 25 | | | | | | | 4.34 * | 4.34 * | 13.59 |
| 20 | | | 6.04 * | 6.04 * | | | 3.52 * | 3.52 * | 19.15 |
| 15 | | | 6.74 * | 6.74 * | 5.72 * | 4.77 | 3.31 * | 3.31 * | 22.24 |
| 10 | 11.15 * | 11.15 * | 9.06 * | 7.58 | 7.51 | 4.62 | 3.38 * | 3.28 | 23.90 |
| 5 | 18.13 * | 13.3 | 11.49 * | 7.02 | 7.25 | 4.39 | 3.66 * | 3.06 | 24.42 |
| 0 | 19.14 * | 12.29 | 11.16 | 6.56 | 7.03 | 4.19 | 4.24 * | 3.1 | 23.89 |
| -5 | 21.32 * | 12.05 | 10.92 | 6.35 | 6.91 | 4.08 | 5.37 * | 3.47 | 22.22 |
| -10 | 18.67 * | 12.22 | 10.97 | 6.39 | | | 7.51 | 4.46 | 19.09 |
| -15 | 12.36 * | 12.36 * | | | | | 8.48 * | 7.88 | 13.56 |

1. Load point is the end of the arm.
2. Capacities marked with an asterisk (*) are limited by hydraulic capacities.
3. Lift capacities shown do not exceed 75% of minimum tipping loads or 87% of hydraulic capacities.
4. The least stable position is over the side.
5. Lift capacities are in compliance with ISO 10567.

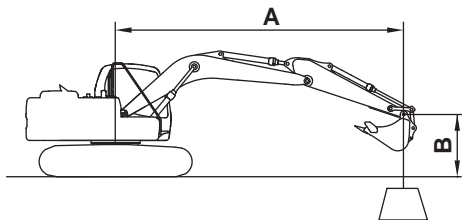
DX140LCR (Boom 4.6 m, Arm 3.0 m, Bucket 0.39 m³)

















- Boom : 4.6 m (15' 0")
- Arm : 3.0 m (9' 10")
- Bucket : 0.39 m³ (0.51 yd³)
- Shoe : 700 mm (2' 4")
- UNIT : 1000 kg (1000 lb)
-  : Rated lift capacity - over front
-  : Rated lift capacity - over side

FG019047

Figure 55









Metric

Unit: 1,000 kg

| A (m) \ B (m) | 2 | | 3 | | 4 | | 5 | | 6 | | 7 | | Max. Reach | | | |
|---------------|---|---|---|---|---|---|---|---|---|--|---|---|---|---|--------|------|
| |  |  |  |  |  |  |  |  |  |  |  |  |  |  | Reach | |
| 8 | | | | | | | | | | | | | | 2.19 * | 2.19 * | 3.49 |
| 7 | | | | | 2.71 * | 2.71 * | | | | | | | | 1.76 * | 1.76 * | 4.97 |
| 6 | | | | | 2.81 * | 2.81 * | 2.62 * | 2.62 * | | | | | | 1.59 * | 1.59 * | 5.91 |
| 5 | | | | | 2.88 * | 2.88 * | 2.91 * | 2.91 * | 2.44 * | 2.27 | | | | 1.51 * | 1.51 * | 6.57 |
| 4 | | | 2.97 * | 2.97 * | 3.28 * | 3.28 * | 3.30 * | 3.1 | 2.95 * | 2.25 | 1.53 * | 1.53 * | 1.50 * | 1.50 * | 7.01 | |
| 3 | | | 5.35 * | 5.35 * | 4.49 * | 4.34 | 3.94 * | 3 | 3.52 * | 2.19 | 2.30 * | 1.64 | 1.53 * | 1.51 | 7.29 | |
| 2 | | | 7.52 * | 6.52 | 5.51 * | 4.1 | 4.52 * | 2.87 | 3.47 | 2.12 | 2.68 | 1.61 | 1.61 * | 1.43 | 7.43 | |
| 1 | | | 9.15 * | 6.06 | 6.43 * | 3.87 | 4.56 | 2.74 | 3.39 | 2.05 | 2.63 | 1.57 | 1.73 * | 1.41 | 7.42 | |
| 0 | | | 8.30 * | 5.81 | 6.44 | 3.71 | 4.45 | 2.64 | 3.32 | 1.98 | 2.6 | 1.54 | 1.93 * | 1.44 | 7.28 | |
| -1 | 5.29 * | 5.29 * | 9.10 * | 5.72 | 6.33 | 3.62 | 4.38 | 2.58 | 3.28 | 1.94 | | | 2.22 * | 1.53 | 6.99 | |
| -2 | 7.05 * | 7.05 * | 9.57 * | 5.72 | 6.3 | 3.59 | 4.35 | 2.55 | 3.27 | 1.93 | | | 2.70 * | 1.7 | 6.53 | |
| -3 | 9.30 * | 9.30 * | 8.65 * | 5.78 | 6.33 | 3.62 | 4.37 | 2.57 | | | | | 3.42 | 2.04 | 5.86 | |
| -4 | 9.74 * | 9.74 * | 7.08 * | 5.92 | 5.34 * | 3.71 | | | | | | | 3.96 * | 2.74 | 4.90 | |

Feet



Unit: 1,000 lb

| A (ft) \ B (ft) | 10 | | 15 | | 20 | | Max. Reach | | |
|-----------------|---|---|---|---|---|---|---|---|-------|
| |  |  |  |  |  |  |  |  | Reach |
| 25 | | | | | | | 4.34 * | 4.34 * | 13.59 |
| 20 | | | 6.04 * | 6.04 * | | | 3.52 * | 3.52 * | 19.15 |
| 15 | | | 6.74 * | 6.74 * | 5.72 * | 4.85 | 3.31 * | 3.31 * | 22.24 |
| 10 | 11.15 * | 11.15 * | 9.06 * | 7.69 | 7.53 * | 4.7 | 3.38 * | 3.34 | 23.90 |
| 5 | 18.13 * | 13.5 | 11.49 * | 7.13 | 7.37 | 4.47 | 3.66 * | 3.12 | 24.42 |
| 0 | 19.14 * | 12.49 | 11.35 | 6.67 | 7.15 | 4.26 | 4.24 * | 3.17 | 23.89 |
| -5 | 21.32 * | 12.25 | 11.11 | 6.46 | 7.04 | 4.16 | 5.37 * | 3.54 | 22.22 |
| -10 | 18.67 * | 12.42 | 11.15 | 6.5 | | | 7.64 | 4.54 | 19.09 |
| -15 | 12.36 * | 12.36 * | | | | | 8.48 * | 8.01 | 13.56 |

1. Load point is the end of the arm.
2. Capacities marked with an asterisk (*) are limited by hydraulic capacities.
3. Lift capacities shown do not exceed 75% of minimum tipping loads or 87% of hydraulic capacities.
4. The least stable position is over the side.
5. Lift capacities are in compliance with ISO 10567.

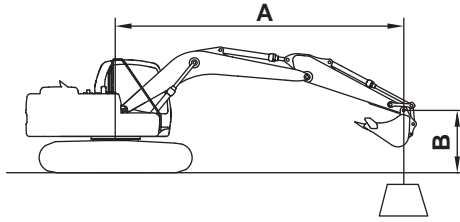
DX140LCR (Boom 4.6 m, Arm 2.5 m, Bucket 0.51 m³)

















- Boom : 4.6 m (15' 0")
- Arm : 2.5 m (8' 2")
- Bucket : 0.51 m³ (0.67 yd³)
- Shoe : 500 mm (1' 8")
- UNIT : 1000 kg (1000 lb)
-  : Rated lift capacity - over front
-  : Rated lift capacity - over side

FG019045

Figure 56









Metric

Unit: 1,000 kg

| A (m) \ B (m) | 2 | | 3 | | 4 | | 5 | | 6 | | 7 | | Max. Reach | | | |
|---------------|---|---|---|---|---|---|---|---|---|---|---|---|---|---|--------|------|
| |  |  |  |  |  |  |  |  |  |  |  |  |  |  | Reach | |
| 8 | | | | | | | | | | | | | | 2.71 * | 2.71 * | 2.55 |
| 7 | | | | | 2.71 * | 2.71 * | | | | | | | | 1.93 * | 1.93 * | 4.37 |
| 6 | | | | | 3.28 * | 3.28 * | 2.66 * | 2.66 * | | | | | | 1.68 * | 1.68 * | 5.42 |
| 5 | | | | | 3.50 * | 3.50 * | 3.34 * | 3 | 2.03 * | 2.03 * | | | | 1.57 * | 1.57 * | 6.13 |
| 4 | | | 4.07 * | 4.07 * | 4.17 * | 4.17 * | 3.86 * | 2.94 | 3.12 * | 2.12 | | | | 1.54 * | 1.54 * | 6.61 |
| 3 | | | 6.54 * | 6.54 * | 5.08 * | 4.12 | 4.33 * | 2.85 | 3.39 | 2.08 | | | | 1.56 * | 1.56 * | 6.91 |
| 2 | | | 8.51 * | 6.13 | 6.04 * | 3.89 | 4.51 | 2.73 | 3.33 | 2.02 | 1.90 * | 1.52 | | 1.63 * | 1.5 | 7.05 |
| 1 | | | 6.97 * | 5.76 | 6.36 | 3.7 | 4.39 | 2.62 | 3.26 | 1.96 | 2.03 * | 1.5 | | 1.75 * | 1.48 | 7.05 |
| 0 | | | 7.17 * | 5.61 | 6.22 | 3.58 | 4.3 | 2.54 | 3.21 | 1.91 | | | | 1.95 * | 1.52 | 6.89 |
| -1 | 5.19 * | 5.19 * | 8.90 * | 5.58 | 6.15 | 3.52 | 4.25 | 2.5 | 3.18 | 1.89 | | | | 2.26 * | 1.63 | 6.58 |
| -2 | 7.48 * | 7.48 * | 9.14 * | 5.62 | 6.15 | 3.52 | 4.24 | 2.5 | 3.2 | 1.9 | | | | 2.77 * | 1.86 | 6.09 |
| -3 | 10.45 * | 10.45 * | 7.94 * | 5.72 | 6.08 * | 3.58 | 4.3 | 2.55 | | | | | | 3.77 * | 2.3 | 5.37 |
| -4 | | | 5.91 * | 5.9 | 4.31 * | 3.71 | | | | | | | | 3.76 * | 3.35 | 4.29 |

Feet



Unit: 1,000 lb

| A (ft) \ B (ft) | 10 | | 15 | | 20 | | Max. Reach | | |
|-----------------|---|---|---|---|---|---|---|---|-------|
| |  |  |  |  |  |  |  |  | Reach |
| 25 | 6.51 * | 6.51 * | | | | | 5.03 * | 5.03 * | 11.13 |
| 20 | | | 6.65 * | 6.65 * | | | 3.74 * | 3.74 * | 17.50 |
| 15 | 7.62 * | 7.62 * | 8.10 * | 7.68 | 5.30 * | 4.55 | 3.42 * | 3.42 * | 20.86 |
| 10 | 13.99 * | 13.99 * | 10.06 * | 7.3 | 7.28 | 4.46 | 3.44 * | 3.44 * | 22.62 |
| 5 | 19.94 * | 12.74 | 11.38 | 6.8 | 7.07 | 4.27 | 3.71 * | 3.27 | 23.18 |
| 0 | 16.52 * | 12.06 | 10.95 | 6.43 | 6.9 | 4.11 | 4.30 * | 3.35 | 22.62 |
| -5 | 20.68 * | 12.01 | 10.81 | 6.3 | 6.85 | 4.06 | 5.49 * | 3.82 | 20.84 |
| -10 | 17.12 * | 12.29 | 10.95 | 6.42 | | | 8.48 * | 5.14 | 17.47 |
| -15 | 6.51 * | 6.51 * | | | | | 5.03 * | 5.03 * | 11.13 |

1. Load point is the end of the arm.
2. Capacities marked with an asterisk (*) are limited by hydraulic capacities.
3. Lift capacities shown do not exceed 75% of minimum tipping loads or 87% of hydraulic capacities.
4. The least stable position is over the side.
5. Lift capacities are in compliance with ISO 10567.

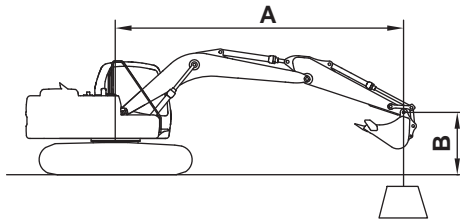
DX140LCR (Boom 4.6 m, Arm 2.5 m, Bucket 0.51 m³)

















- Boom : 4.6 m (15' 0")
- Arm : 2.5 m (8' 2")
- Bucket : 0.51 m³ (0.67 yd³)
- Shoe : 500 mm (1' 8") Rubber
- UNIT : 1000 kg (1000 lb)
-  : Rated lift capacity - over front
-  : Rated lift capacity - over side

FG019046

Figure 57









Metric

Unit: 1,000 kg

| A (m) \ B (m) | 2 | | 3 | | 4 | | 5 | | 6 | | 7 | | Max. Reach | | | |
|---------------|---|---|---|---|---|---|---|---|---|--|---|---|---|---|--------|------|
| |  |  |  |  |  |  |  |  |  |  |  |  |  |  | Reach | |
| 8 | | | | | | | | | | | | | | 2.71 * | 2.71 * | 2.55 |
| 7 | | | | | 2.71 * | 2.71 * | | | | | | | | 1.93 * | 1.93 * | 4.37 |
| 6 | | | | | 3.28 * | 3.28 * | 2.66 * | 2.66 * | | | | | | 1.68 * | 1.68 * | 5.42 |
| 5 | | | | | 3.50 * | 3.50 * | 3.34 * | 2.98 | 2.03 * | 2.03 * | | | | 1.57 * | 1.57 * | 6.13 |
| 4 | | | 4.07 * | 4.07 * | 4.17 * | 4.17 * | 3.86 * | 2.93 | 3.12 * | 2.11 | | | | 1.54 * | 1.54 * | 6.61 |
| 3 | | | 6.54 * | 6.54 * | 5.08 * | 4.1 | 4.33 * | 2.83 | 3.38 | 2.07 | | | | 1.56 * | 1.56 * | 6.91 |
| 2 | | | 8.51 * | 6.1 | 6.04 * | 3.88 | 4.49 | 2.72 | 3.31 | 2.01 | 1.90 * | 1.51 | | 1.63 * | 1.49 | 7.05 |
| 1 | | | 6.97 * | 5.74 | 6.33 | 3.68 | 4.37 | 2.61 | 3.24 | 1.95 | 2.03 * | 1.49 | | 1.75 * | 1.47 | 7.04 |
| 0 | | | 7.17 * | 5.59 | 6.19 | 3.56 | 4.27 | 2.53 | 3.19 | 1.9 | | | | 1.95 * | 1.51 | 6.89 |
| -1 | 5.19 * | 5.19 * | 8.90 * | 5.56 | 6.12 | 3.5 | 4.23 | 2.49 | 3.17 | 1.88 | | | | 2.26 * | 1.62 | 6.58 |
| -2 | 7.48 * | 7.48 * | 9.14 * | 5.59 | 6.12 | 3.5 | 4.22 | 2.48 | 3.18 | 1.89 | | | | 2.77 * | 1.85 | 6.09 |
| -3 | 10.45 * | 10.45 * | 7.94 * | 5.69 | 6.08 * | 3.56 | 4.28 | 2.53 | | | | | | 3.77 * | 2.28 | 5.37 |
| -4 | | | 5.91 * | 5.87 | 4.31 * | 3.69 | | | | | | | | 3.76 * | 3.34 | 4.29 |

Feet



Unit: 1,000 lb

| A (ft) \ B (ft) | 10 | | 15 | | 20 | | Max. Reach | | |
|-----------------|---|---|---|---|---|---|---|---|-------|
| |  |  |  |  |  |  |  |  | Reach |
| 25 | 6.51 * | 6.51 * | | | | | 5.03 * | 5.03 * | 11.13 |
| 20 | | | 6.65 * | 6.65 * | | | 3.74 * | 3.74 * | 17.50 |
| 15 | 7.62 * | 7.62 * | 8.10 * | 7.65 | 5.30 * | 4.53 | 3.42 * | 3.42 * | 20.86 |
| 10 | 13.99 * | 13.99 * | 10.06 * | 7.27 | 7.24 | 4.43 | 3.44 * | 3.44 * | 22.62 |
| 5 | 19.94 * | 12.68 | 11.32 | 6.77 | 7.04 | 4.24 | 3.71 * | 3.25 | 23.18 |
| 0 | 16.52 * | 12 | 10.9 | 6.4 | 6.86 | 4.08 | 4.30 * | 3.33 | 22.62 |
| -5 | 20.68 * | 11.95 | 10.75 | 6.27 | 6.81 | 4.04 | 5.49 * | 3.8 | 20.84 |
| -10 | 17.12 * | 12.23 | 10.89 | 6.39 | | | 8.48 * | 5.11 | 17.47 |

1. Load point is the end of the arm.
2. Capacities marked with an asterisk (*) are limited by hydraulic capacities.
3. Lift capacities shown do not exceed 75% of minimum tipping loads or 87% of hydraulic capacities.
4. The least stable position is over the side.
5. Lift capacities are in compliance with ISO 10567.

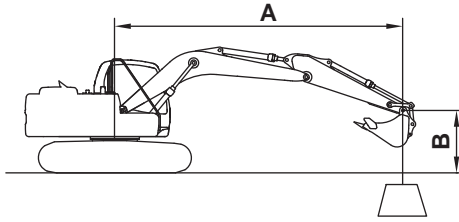
DX140LCR (Boom 4.6 m, Arm 2.5 m, Bucket 0.51 m³)

















- Boom : 4.6 m (15' 0")
- Arm : 2.5 m (8' 2")
- Bucket : 0.51 m³ (0.67 yd³)
- Shoe : 600 mm (2') Rubber
- UNIT : 1000 kg (1000 lb)
-  : Rated lift capacity - over front
-  : Rated lift capacity - over side

FG019048

Figure 58









Metric

Unit: 1,000 kg

| A (m) \ B (m) | 2 | | 3 | | 4 | | 5 | | 6 | | 7 | | Max. Reach | | | |
|---------------|---|---|---|---|---|---|---|---|---|--|---|---|---|---|--------|------|
| |  |  |  |  |  |  |  |  |  |  |  |  |  |  | Reach | |
| 8 | | | | | | | | | | | | | | 2.71 * | 2.71 * | 2.55 |
| 7 | | | | | 2.71 * | 2.71 * | | | | | | | | 1.93 * | 1.93 * | 4.37 |
| 6 | | | | | 3.28 * | 3.28 * | 2.66 * | 2.66 * | | | | | | 1.68 * | 1.68 * | 5.42 |
| 5 | | | | | 3.50 * | 3.50 * | 3.34 * | 3.04 | 2.03 * | 2.03 * | | | | 1.57 * | 1.57 * | 6.13 |
| 4 | | | 4.07 * | 4.07 * | 4.17 * | 4.17 * | 3.86 * | 2.99 | 3.12 * | 2.16 | | | | 1.54 * | 1.54 * | 6.61 |
| 3 | | | 6.54 * | 6.54 * | 5.08 * | 4.18 | 4.33 * | 2.89 | 3.45 | 2.11 | | | | 1.56 * | 1.56 * | 6.91 |
| 2 | | | 8.51 * | 6.22 | 6.04 * | 3.95 | 4.58 | 2.78 | 3.38 | 2.05 | 1.90 * | 1.55 | 1.63 * | 1.53 | 7.05 | |
| 1 | | | 6.97 * | 5.86 | 6.46 | 3.76 | 4.46 | 2.67 | 3.32 | 1.99 | 2.03 * | 1.53 | 1.75 * | 1.51 | 7.05 | |
| 0 | | | 7.17 * | 5.7 | 6.32 | 3.64 | 4.37 | 2.59 | 3.27 | 1.95 | | | 1.95 * | 1.55 | 6.89 | |
| -1 | 5.19 * | 5.19 * | 8.90 * | 5.67 | 6.25 | 3.58 | 4.32 | 2.55 | 3.24 | 1.92 | | | 2.26 * | 1.66 | 6.58 | |
| -2 | 7.48 * | 7.48 * | 9.14 * | 5.71 | 6.25 | 3.58 | 4.32 | 2.54 | 3.25 | 1.93 | | | 2.77 * | 1.89 | 6.09 | |
| -3 | 10.45 * | 10.45 * | 7.94 * | 5.81 | 6.08 * | 3.64 | 4.37 | 2.59 | | | | | 3.77 * | 2.34 | 5.37 | |
| -4 | | | 5.91 * | 5.91 * | 4.31 * | 3.77 | | | | | | | 3.76 * | 3.41 | 4.29 | |

Feet



Unit: 1,000 lb

| A (ft) \ B (ft) | 10 | | 15 | | 20 | | Max. Reach | | |
|-----------------|---|---|---|---|---|---|---|---|-------|
| |  |  |  |  |  |  |  |  | Reach |
| 25 | 6.51 * | 6.51 * | | | | | 5.03 * | 5.03 * | 11.13 |
| 20 | | | 6.65 * | 6.65 * | | | 3.74 * | 3.74 * | 17.50 |
| 15 | 7.62 * | 7.62 * | 8.10 * | 7.8 | 5.30 * | 4.63 | 3.42 * | 3.42 * | 20.86 |
| 10 | 13.99 * | 13.99 * | 10.06 * | 7.41 | 7.4 | 4.53 | 3.44 * | 3.44 * | 22.62 |
| 5 | 19.94 * | 12.94 | 11.56 | 6.91 | 7.2 | 4.34 | 3.71 * | 3.33 | 23.18 |
| 0 | 16.52 * | 12.25 | 11.14 | 6.54 | 7.02 | 4.18 | 4.30 * | 3.41 | 22.62 |
| -5 | 20.68 * | 12.2 | 10.99 | 6.42 | 6.97 | 4.14 | 5.49 * | 3.89 | 20.84 |
| -10 | 17.12 * | 12.48 | 11.13 | 6.54 | | | 8.48 * | 5.23 | 17.47 |

1. Load point is the end of the arm.
2. Capacities marked with an asterisk (*) are limited by hydraulic capacities.
3. Lift capacities shown do not exceed 75% of minimum tipping loads or 87% of hydraulic capacities.
4. The least stable position is over the side.
5. Lift capacities are in compliance with ISO 10567.

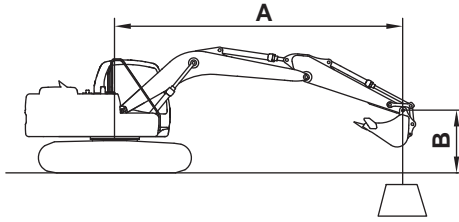
DX140LCR (Boom 4.6 m, Arm 2.5 m, Bucket 0.51 m³)

















- Boom : 4.6 m (15' 0")
- Arm : 2.5 m (8' 2")
- Bucket : 0.51 m³ (0.67 yd³)
- Shoe : 700 mm (2' 4") Rubber
- UNIT : 1000 kg (1000 lb)
-  : Rated lift capacity - over front
-  : Rated lift capacity - over side

FG019049

Figure 59









Metric

Unit: 1,000 kg

| A (m) \ B (m) | 2 | | 3 | | 4 | | 5 | | 6 | | 7 | | Max. Reach | | | |
|---------------|---|---|---|---|---|---|---|---|---|--|---|---|---|---|--------|------|
| |  |  |  |  |  |  |  |  |  |  |  |  |  |  | Reach | |
| 8 | | | | | | | | | | | | | | 2.71 * | 2.71 * | 2.55 |
| 7 | | | | | 2.71 * | 2.71 * | | | | | | | | 1.93 * | 1.93 * | 4.37 |
| 6 | | | | | 3.28 * | 3.28 * | 2.66 * | 2.66 * | | | | | | 1.68 * | 1.68 * | 5.42 |
| 5 | | | | | 3.50 * | 3.50 * | 3.34 * | 3.09 | 2.03 * | 2.03 * | | | | 1.57 * | 1.57 * | 6.13 |
| 4 | | | 4.07 * | 4.07 * | 4.17 * | 4.17 * | 3.86 * | 3.03 | 3.12 * | 2.19 | | | | 1.54 * | 1.54 * | 6.61 |
| 3 | | | 6.54 * | 6.54 * | 5.08 * | 4.24 | 4.33 * | 2.94 | 3.5 | 2.15 | | | | 1.56 * | 1.56 * | 6.91 |
| 2 | | | 8.51 * | 6.31 | 6.04 * | 4.01 | 4.65 | 2.82 | 3.44 | 2.09 | 1.90 * | 1.58 | | 1.63 * | 1.56 | 7.05 |
| 1 | | | 6.97 * | 5.95 | 6.57 | 3.82 | 4.53 | 2.72 | 3.37 | 2.03 | 2.03 * | 1.56 | | 1.75 * | 1.54 | 7.04 |
| 0 | | | 7.17 * | 5.8 | 6.42 | 3.7 | 4.44 | 2.63 | 3.32 | 1.98 | | | | 1.95 * | 1.58 | 6.89 |
| -1 | 5.19 * | 5.19 * | 8.90 * | 5.77 | 6.35 | 3.64 | 4.39 | 2.59 | 3.3 | 1.96 | | | | 2.26 * | 1.7 | 6.58 |
| -2 | 7.48 * | 7.48 * | 9.14 * | 5.81 | 6.36 | 3.64 | 4.39 | 2.59 | 3.31 | 1.97 | | | | 2.77 * | 1.93 | 6.09 |
| -3 | 10.45 * | 10.45 * | 7.94 * | 5.9 | 6.08 * | 3.7 | 4.44 | 2.64 | | | | | | 3.77 * | 2.38 | 5.37 |
| -4 | | | 5.91 * | 5.91 * | 4.31 * | 3.83 | | | | | | | | 3.76 * | 3.46 | 4.29 |

Feet



Unit: 1,000 lb

| A (ft) \ B (ft) | 10 | | 15 | | 20 | | Max. Reach | | |
|-----------------|---|---|---|---|---|---|---|---|-------|
| |  |  |  |  |  |  |  |  | Reach |
| 25 | 6.51 * | 6.51 * | | | | | 5.03 * | 5.03 * | 11.13 |
| 20 | | | 6.65 * | 6.65 * | | | 3.74 * | 3.74 * | 17.50 |
| 15 | 7.62 * | 7.62 * | 8.10 * | 7.91 | 5.30 * | 4.71 | 3.42 * | 3.42 * | 20.86 |
| 10 | 13.99 * | 13.99 * | 10.06 * | 7.52 | 7.52 | 4.61 | 3.44 * | 3.44 * | 22.62 |
| 5 | 19.94 * | 13.14 | 11.74 | 7.02 | 7.32 | 4.42 | 3.71 * | 3.4 | 23.18 |
| 0 | 16.52 * | 12.45 | 11.32 | 6.66 | 7.14 | 4.26 | 4.30 * | 3.48 | 22.62 |
| -5 | 20.68 * | 12.4 | 11.17 | 6.53 | 7.09 | 4.22 | 5.49 * | 3.97 | 20.84 |
| -10 | 17.12 * | 12.68 | 11.31 | 6.65 | | | 8.48 * | 5.32 | 17.47 |

1. Load point is the end of the arm.
2. Capacities marked with an asterisk (*) are limited by hydraulic capacities.
3. Lift capacities shown do not exceed 75% of minimum tipping loads or 87% of hydraulic capacities.
4. The least stable position is over the side.
5. Lift capacities are in compliance with ISO 10567.

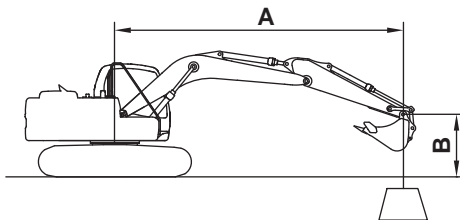
DX140LCR (Boom 4.6 m, Arm 2.1 m, Bucket 0.51 m³)















- Boom : 4.6 m (15' 0")
- Arm : 2.1 m (6' 11")
- Bucket : 0.51 m³ (0.67 yd³)
- Shoe : 600 mm (2')
- UNIT : 1000 kg (1000 lb)
-  : Rated lift capacity - over front
-  : Rated lift capacity - over side

FG019050

Figure 60









Metric

Unit: 1,000 kg

| A (m) \ B (m) | 2 | | 3 | | 4 | | 5 | | 6 | | Max. Reach | | | |
|---------------|---|---|---|---|---|---|---|---|---|---|---|---|--------|------|
| |  |  |  |  |  |  |  |  |  |  |  |  | Reach | |
| 7 | | | 3.94 * | 3.94 * | | | | | | | | 2.92 * | 2.92 * | 3.57 |
| 6 | | | 3.91 * | 3.91 * | 3.94 * | 3.94 * | | | | | | 2.52 * | 2.52 * | 4.81 |
| 5 | | | 4.35 * | 4.35 * | 4.10 * | 4.10 * | 3.92 * | 3 | | | | 2.38 * | 2.38 * | 5.59 |
| 4 | 7.34 * | 7.34 * | 5.54 * | 5.54 * | 4.67 * | 4.31 | 4.20 * | 2.96 | 2.91 * | 2.13 | 2.36 * | 2.05 | 6.12 | |
| 3 | | | 7.40 * | 6.56 | 5.53 * | 4.12 | 4.63 * | 2.87 | 3.43 | 2.1 | 2.43 * | 1.84 | 6.44 | |
| 2 | | | | | 6.43 * | 3.9 | 4.56 | 2.76 | 3.38 | 2.05 | 2.57 * | 1.73 | 6.59 | |
| 1 | | | | | 6.43 | 3.73 | 4.45 | 2.67 | 3.32 | 2 | 2.81 * | 1.71 | 6.59 | |
| 0 | | | 7.17 * | 5.7 | 6.31 | 3.64 | 4.38 | 2.6 | 3.28 | 1.96 | 2.94 | 1.76 | 6.43 | |
| -1 | 5.73 * | 5.73 * | 9.52 * | 5.71 | 6.28 | 3.6 | 4.35 | 2.57 | 3.27 | 1.95 | 3.2 | 1.91 | 6.09 | |
| -2 | 8.82 * | 8.82 * | 8.65 * | 5.78 | 6.3 | 3.63 | 4.36 | 2.59 | | | 3.71 | 2.22 | 5.55 | |
| -3 | 9.35 * | 9.35 * | 7.22 * | 5.91 | 5.58 * | 3.71 | | | | | 4.37 * | 2.88 | 4.74 | |

Feet



Unit: 1,000 kg

| A (ft) \ B (ft) | 10 | | 15 | | 20 | | Max. Reach | | |
|-----------------|---|---|---|---|---|---|---|---|-------|
| |  |  |  |  |  |  |  |  | Reach |
| 25 | | | | | | | 8.03 * | 8.03 * | 7.45 |
| 20 | 8.62 * | 8.62 * | 6.58 * | 6.58 * | | | 5.61 * | 5.61 * | 15.46 |
| 15 | 10.44 * | 10.44 * | 9.09 * | 7.7 | | | 5.21 * | 4.93 | 19.18 |
| 10 | 15.81 * | 14.15 | 10.84 * | 7.33 | 7.36 | 4.5 | 5.34 * | 4.07 | 21.09 |
| 5 | | | 11.49 | 6.86 | 7.19 | 4.35 | 5.88 * | 3.78 | 21.69 |
| 0 | 16.55 * | 12.24 | 11.14 | 6.56 | 7.05 | 4.22 | 6.49 | 3.88 | 21.09 |
| -5 | 19.84 * | 12.32 | 11.07 | 6.49 | | | 7.54 | 4.51 | 19.16 |
| -10 | 15.54 * | 12.7 | 10.15 * | 6.7 | | | 9.63 * | 6.43 | 15.44 |

1. Load point is the end of the arm.
2. Capacities marked with an asterisk (*) are limited by hydraulic capacities.
3. Lift capacities shown do not exceed 75% of minimum tipping loads or 87% of hydraulic capacities.
4. The least stable position is over the side.
5. Lift capacities are in compliance with ISO 10567.

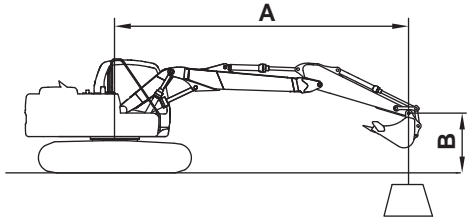
DX140LCR (Boom 5.0 m Two-pieces, Arm 2.5 m, Bucket 0.51 m³)

















- Boom : 5.0 m (16' 4") Two-piece Boom
- Arm : 2.5 m (8' 2")
- Bucket : 0.45 m³ (0.59 yd³)
- Shoe : 600 mm (2') Rubber
- UNIT : 1000 kg (1000 lb)
-  : Rated lift capacity - over front
-  : Rated lift capacity - over side

FG019051

Figure 61









Metric

Unit: 1,000 kg

| A (m) \ B (m) | 2 | | 3 | | 4 | | 5 | | 6 | | 7 | | Max. Reach | | | |
|---------------|---|---|---|---|---|---|---|---|---|---|---|---|---|---|--------|------|
| |  |  |  |  |  |  |  |  |  |  |  |  |  |  | Reach | |
| 8 | | | | | | | | | | | | | | 1.69 * | 1.69 * | 3.82 |
| 7 | | | | | 2.83 * | 2.83 * | 2.19 * | 2.19 * | | | | | | 1.25 * | 1.25 * | 5.21 |
| 6 | | | | | 2.76 * | 2.76 * | 2.90 * | 2.90 * | 1.72 * | 1.72 * | | | | 1.06 * | 1.06 * | 6.11 |
| 5 | | | | | 3.09 * | 3.09 * | 3.03 * | 3.03 * | 3.03 * | 2.18 | | | | 0.96 * | 0.96 * | 6.74 |
| 4 | | | 4.43 * | 4.43 * | 3.76 * | 3.76 * | 3.39 * | 2.97 | 3.19 * | 2.14 | 2.01 * | 1.57 | | 0.92 * | 0.92 * | 7.18 |
| 3 | | | | | 4.70 * | 4.08 | 3.91 * | 2.84 | 3.44 | 2.08 | 2.62 | 1.55 | | 0.90 * | 0.90 * | 7.46 |
| 2 | | | | | 5.69 * | 3.81 | 4.47 * | 2.69 | 3.35 | 2 | 2.58 | 1.51 | | 0.92 * | 0.92 * | 7.59 |
| 1 | | | | | 6.31 | 3.59 | 4.38 | 2.56 | 3.27 | 1.92 | 2.54 | 1.47 | | 0.96 * | 0.96 * | 7.58 |
| 0 | | | | | 6.16 | 3.46 | 4.27 | 2.47 | 3.2 | 1.86 | 2.51 | 1.44 | | 1.04 * | 1.04 * | 7.44 |
| -1 | | | 6.25 * | 5.42 | 6.1 | 3.41 | 4.22 | 2.43 | 3.17 | 1.83 | 2.5 | 1.44 | | 1.16 * | 1.16 * | 7.16 |
| -2 | 5.83 * | 5.83 * | 8.74 * | 5.48 | 6.11 | 3.42 | 4.22 | 2.42 | 3.17 | 1.83 | | | | 1.36 * | 1.36 * | 6.71 |
| -3 | | | 8.35 * | 5.59 | 6.18 | 3.48 | 4.26 | 2.46 | 2.65 * | 1.9 | | | | 1.68 * | 1.68 * | 6.06 |

Feet



Unit: 1,000 lb

| A (ft) \ B (ft) | 10 | | 15 | | 20 | | Max. Reach | | |
|-----------------|---|---|---|---|---|---|---|---|-------|
| |  |  |  |  |  |  |  |  | Reach |
| 25 | | | | | | | 3.23 * | 3.23 * | 14.52 |
| 20 | | | 6.25 * | 6.25 * | | | 2.37 * | 2.37 * | 19.79 |
| 15 | | | 7.11 * | 7.11 * | 6.78 * | 4.64 | 2.07 * | 2.07 * | 22.82 |
| 10 | | | 9.15 * | 7.27 | 7.38 | 4.46 | 1.99 * | 1.99 * | 24.43 |
| 5 | | | 11.35 | 6.65 | 7.11 | 4.21 | 2.07 * | 2.07 * | 24.94 |
| 0 | | | 10.88 | 6.24 | 6.89 | 4 | 2.30 * | 2.30 * | 24.42 |
| -5 | 16.88 * | 11.68 | 10.74 | 6.11 | 6.81 | 3.93 | 2.76 * | 2.76 * | 22.78 |
| -10 | 18.05 * | 12.01 | 10.87 | 6.23 | | | 3.75 * | 3.75 * | 19.77 |

1. Load point is the end of the arm.
2. Capacities marked with an asterisk (*) are limited by hydraulic capacities.
3. Lift capacities shown do not exceed 75% of minimum tipping loads or 87% of hydraulic capacities.
4. The least stable position is over the side.
5. Lift capacities are in compliance with ISO 10567.

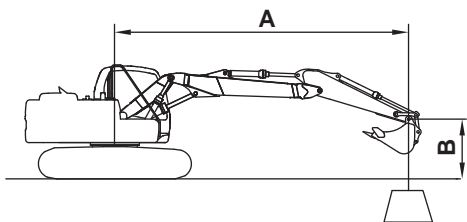
DX140LCR (Boom 5.0 m Two-pieces, Arm 2.1 m, Bucket 0.51 m³)















- Boom : 5.0 m (16' 4") Two-piece Boom
- Arm : 2.1 m (6' 11")
- Bucket : 0.51m³ (0.67 yd³)
- Shoe : 600 mm (2')
- UNIT : 1000 kg (1000 lb)
-  : Rated lift capacity - over front
-  : Rated lift capacity - over side

FG019052

Figure 62









Metric

Unit: 1,000 kg

| A (m) \ B (m) | 3 | | 4 | | 5 | | 6 | | 7 | | Max. Reach | | | | |
|---------------|---|---|---|---|---|---|---|---|---|---|---|---|--------|--------|------|
| |  |  |  |  |  |  |  |  |  |  |  |  | Reach | | |
| 8 | | | | | | | | | | | | | 3.09 * | 3.09 * | 2.79 |
| 7 | | | 3.38 * | 3.38 * | | | | | | | | | 2.22 * | 2.22 * | 4.51 |
| 6 | | | 3.20 * | 3.20 * | 3.28 * | 3.01 | | | | | | | 1.92 * | 1.92 * | 5.53 |
| 5 | | | 3.52 * | 3.52 * | 3.36 * | 3 | 2.99 * | 2.12 | | | | | 1.79 * | 1.79 * | 6.22 |
| 4 | 5.20 * | 5.20 * | 4.20 * | 4.20 * | 3.70 * | 2.92 | 3.44 * | 2.11 | | | | | 1.74 * | 1.68 | 6.70 |
| 3 | | | 5.14 * | 3.99 | 4.19 * | 2.8 | 3.41 | 2.05 | | | | | 1.74 * | 1.52 | 6.99 |
| 2 | | | 6.08 * | 3.73 | 4.48 | 2.66 | 3.33 | 1.98 | 2.56 | 1.5 | | | 1.80 * | 1.44 | 7.13 |
| 1 | | | 6.26 | 3.54 | 4.35 | 2.55 | 3.26 | 1.92 | 2.53 | 1.47 | | | 1.91 * | 1.42 | 7.13 |
| 0 | | | 6.15 | 3.45 | 4.27 | 2.47 | 3.21 | 1.87 | | | | | 2.08 * | 1.46 | 6.98 |
| -1 | 6.79 * | 5.47 | 6.12 | 3.43 | 4.24 | 2.44 | 3.19 | 1.85 | | | | | 2.36 * | 1.58 | 6.67 |
| -2 | 8.76 * | 5.55 | 6.16 | 3.46 | 4.25 | 2.46 | 3.21 | 1.87 | | | | | 2.81 * | 1.8 | 6.19 |
| -3 | | | 6.08 * | 3.54 | 4.33 | 2.52 | | | | | | | 3.78 | 2.23 | 5.47 |

Feet

Unit: 1,000 lb

| A (ft) \ B (ft) | 10 | | 15 | | 20 | | Max. Reach | | |
|-----------------|---|---|---|---|---|---|---|---|-------|
| |  |  |  |  |  |  |  |  | Reach |
| 25 | | | | | | | 5.77 * | 5.77 * | 11.72 |
| 20 | | | 7.13 * | 7.13 * | | | 4.28 * | 4.28 * | 17.88 |
| 15 | 9.42 * | 9.42 * | 7.89 * | 7.66 | 7.40 * | 4.54 | 3.88 * | 3.88 * | 21.17 |
| 10 | | | 9.89 * | 7.14 | 7.32 | 4.4 | 3.84 * | 3.37 | 22.90 |
| 5 | | | 11.25 | 6.57 | 7.08 | 4.18 | 4.06 * | 3.14 | 23.46 |
| 0 | | | 10.87 | 6.23 | 6.9 | 4.02 | 4.59 * | 3.22 | 22.90 |
| -5 | 19.16 * | 11.81 | 10.8 | 6.17 | 6.87 | 4 | 5.66 * | 3.69 | 21.15 |
| -10 | | | 11.02 | 6.37 | | | 8.54 | 5.02 | 17.69 |

1. Load point is the end of the arm.
2. Capacities marked with an asterisk (*) are limited by hydraulic capacities.
3. Lift capacities shown do not exceed 75% of minimum tipping loads or 87% of hydraulic capacities.
4. The least stable position is over the side.
5. Lift capacities are in compliance with ISO 10567.

Operating Controls

The "Operating Controls" section presented here consists of the following groups:

1. "Component Locations" on page 2-2
2. "Operator's Area" on page 2-4
3. "Operational Controls and Panels" on page 2-6
4. "Instrument Panel" on page 2-19
5. "Multifunction Gauge and Graphic Information" on page 2-25
6. "Mode Selector Buttons" on page 2-31
7. "Setting Main Menu" on page 2-33
8. "Heater and Air Conditioner Control Panel" on page 2-48
9. "Stereo" on page 2-53
10. "Miscellaneous Electrical Devices" on page 2-54
11. "Seat Adjustment" on page 2-56
12. "Ceiling Cover" on page 2-60
13. "Front Windows" on page 2-61
14. "Door Side Latch" on page 2-63
15. "Cabin Storage Compartments" on page 2-64
16. "Ashtray" on page 2-64
17. "Sun Visor" on page 2-65
18. "Hanger" on page 2-65
19. "Cup Holder" on page 2-65
20. "Emergency Glass Breaking Tool" on page 2-66
21. "Miscellaneous Access Covers and Doors" on page 2-67

Each group is explained with a point location drawing or photo and a brief description of each control, switch, gauge or valve.

Indicator lights work besides the gauges on the instrument panel. The operator should monitor machine pressure on the instrument panel with indicator lights. These lights will only show there is a problem.



WARNING

AVOID DEATH OR SERIOUS INJURY

Warning lights. When any one or more of the warning lights on the control console, comes "ON", immediately stop operation and stop unit. Investigate and correct the problem before proceeding with operation.

COMPONENT LOCATIONS

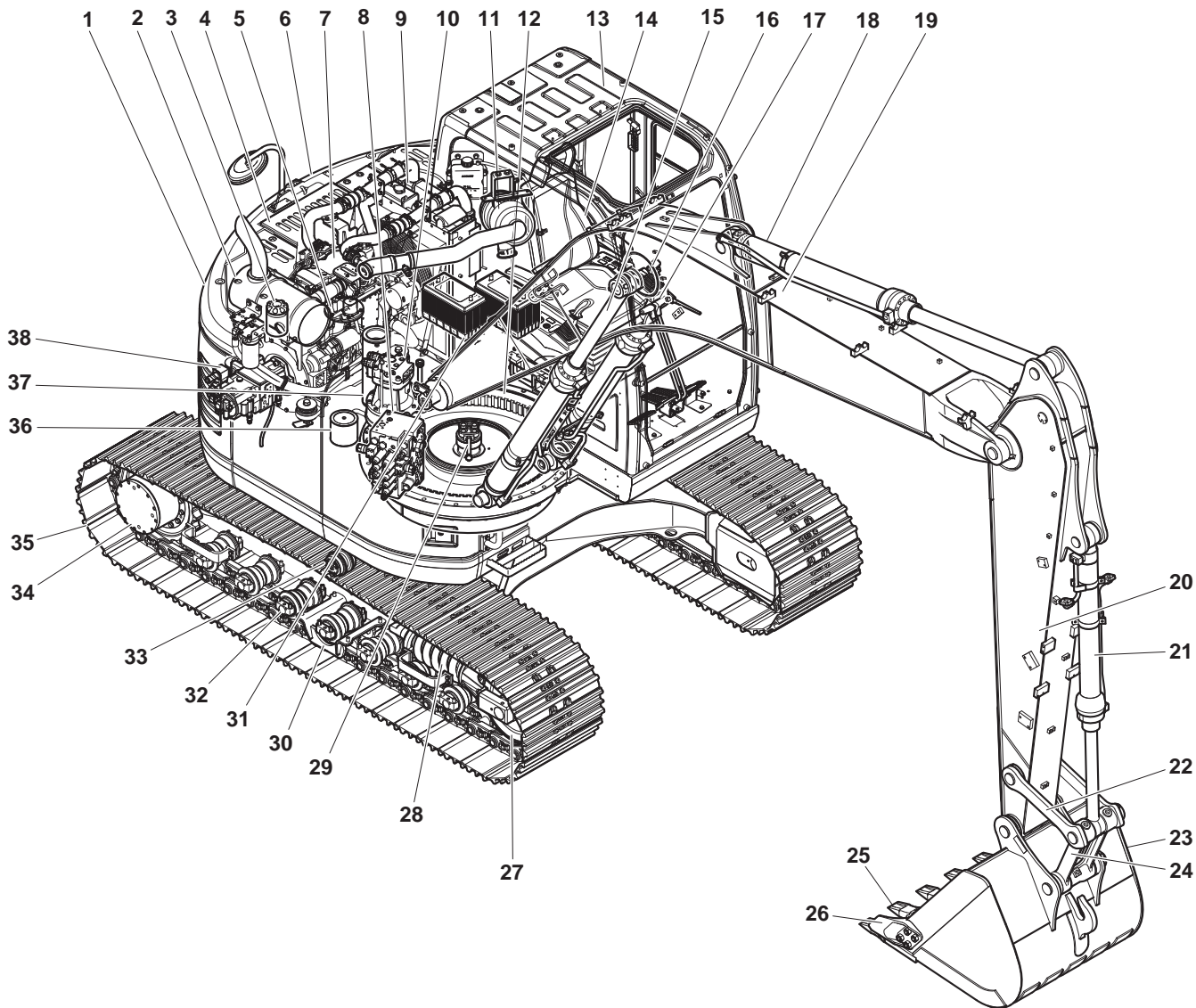

FG014632

Figure 1

| Reference Number | Description |
|------------------|--------------------------------|
| 1 | Counterweight |
| 2 | Muffler |
| 3 | Fuel Tank Fill Cap |
| 4 | Engine Bonnet |
| 5 | Hydraulic Oil Tank |
| 6 | Fuel Tank |
| 7 | Engine |
| 8 | Control Valves |
| 9 | Radiator and Oil Cooler |
| 10 | Swing Motor |
| 11 | Air Cleaner |
| 12 | Swing Bearing |
| 13 | Seat |
| 14 | Cabin |
| 15 | Boom Cylinder |
| 16 | Work Lever (Joystick) Controls |
| 17 | Travel Lever |
| 18 | Arm Cylinder |
| 19 | Boom |

| Reference Number | Description |
|------------------|---------------------|
| 20 | Arm |
| 21 | Bucket Cylinder |
| 22 | Guide Link |
| 23 | Bucket |
| 24 | Push Link |
| 25 | Tooth Point |
| 26 | Side Cutter |
| 27 | Idler |
| 28 | Track Adjuster |
| 29 | Center Joint |
| 30 | Track Guide |
| 31 | Battery |
| 32 | Lower Roller |
| 33 | Upper Roller |
| 34 | Travel Motor |
| 35 | Track Link and Shoe |
| 36 | Suction Filter |
| 37 | Return Filter |
| 38 | Pumps |

OPERATOR'S AREA

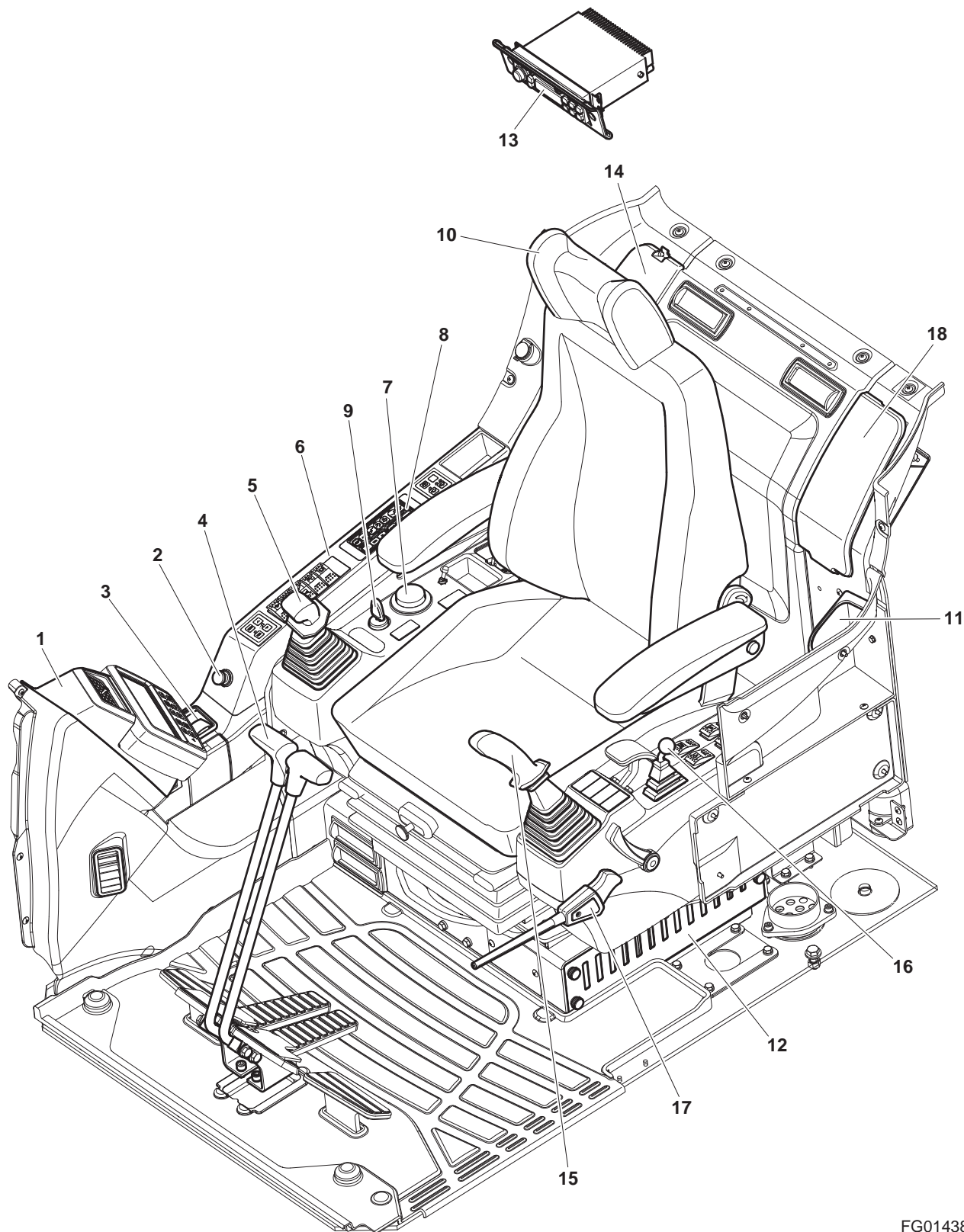

FG014383

Figure 2

| Reference Number | Description |
|------------------|--|
| 1 | Instrument Panel (See page 2-19) |
| 2 | Cigarette Lighter (See page 2-15) |
| 3 | Ashtray (See page 2-64) |
| 4 | Travel Levers (See page 3-15) |
| 5 | Right-hand Work Lever (Joystick) (See page 3-23) |
| 6 | Switch Panel |
| 7 | Engine Speed Control Dial (See page 2-9) |
| 8 | Heater and Air Conditioner Control Panel (See page 2-48) |
| 9 | Starter Switch (See page 2-8) |

| Reference Number | Description |
|------------------|--|
| 10 | Seat (See page 2-56) |
| 11 | Storage Compartment (See page 2-64) |
| 12 | Heater and Air Conditioner Unit |
| 13 | Stereo (See page 2-53) |
| 14 | Fuse Box (See page 2-55) |
| 15 | Left-hand Work Lever (Joystick) (See page 3-22) |
| 16 | Dozer Lever (Optional) (See page 3-25) |
| 17 | Safety Lever (See page 3-12) |
| 18 | Storage Compartment (See page 2-64) |

OPERATIONAL CONTROLS AND PANELS

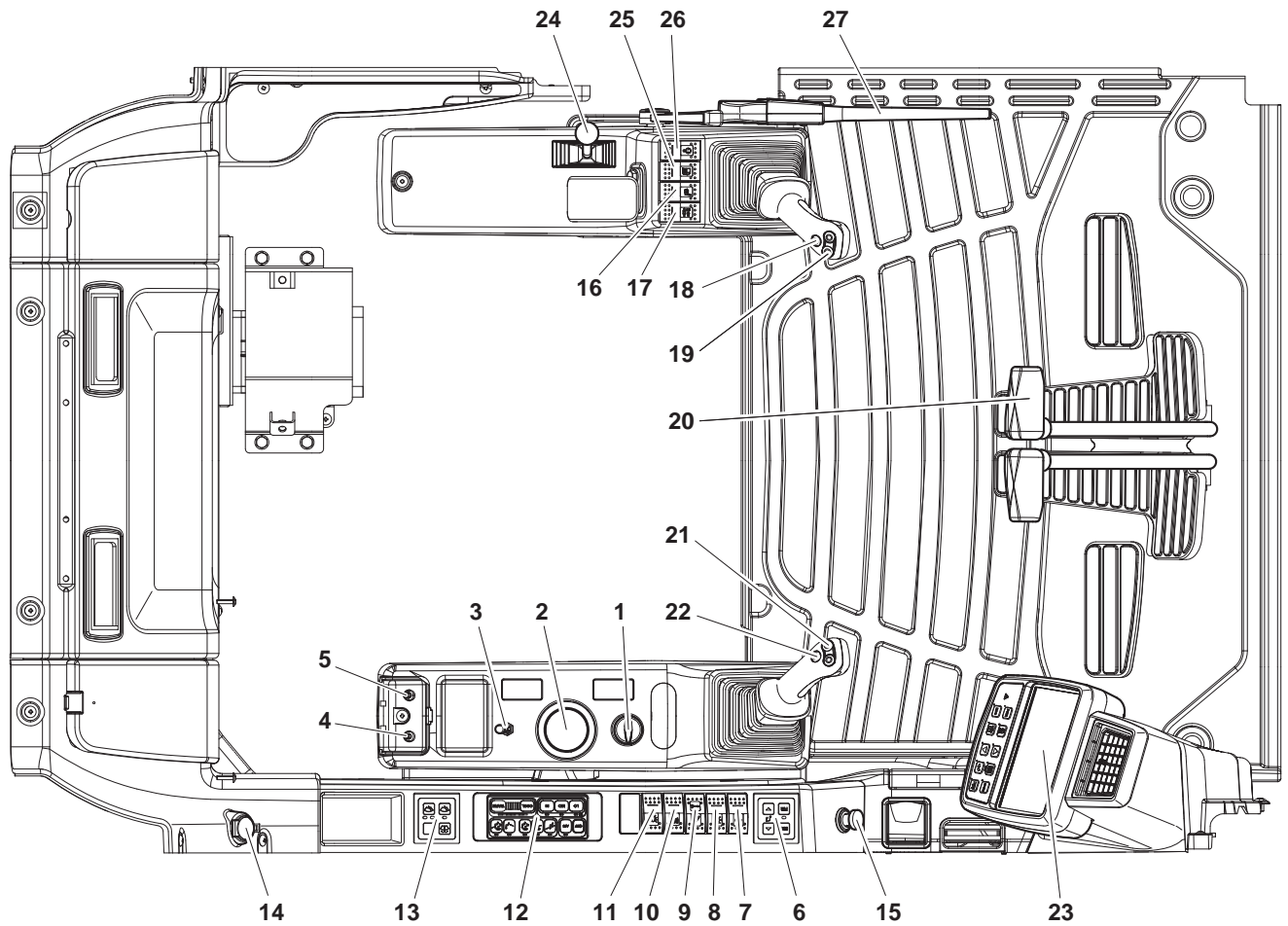

FG017135

Figure 3

| Reference Number | Description |
|------------------|--|
| 1 | Starter Switch |
| 2 | Engine Speed Control Dial |
| 3 | Quick Coupler Switch (Optional) |
| 4 | Auxiliary Mode Switch |
| 5 | Engine Emergency Stop Switch |
| 6 | Audio Control Panel |
| 7 | Travel Speed Selector Switch |
| 8 | Light Switch |
| 9 | Breaker/Booster/Shear Selector Switch |
| 10 | Cabin Work Light Switch (Optional) |
| 11 | Warning Light Switch (Optional) |
| 12 | Heater and Air Conditional Control Panel |
| 13 | Wiper Control Panel |

| Reference Number | Description |
|------------------|--------------------------------------|
| 14 | Power Socket for 12v |
| 15 | Cigarette Lighter |
| 16 | Seat Warmer Switch (Optional) |
| 17 | Travel/Swing Alarm Switch (Optional) |
| 18 | Horn Button |
| 19 | Rotating Buttons |
| 20 | Travel Lever |
| 21 | Shear Buttons |
| 22 | Booster Button |
| 23 | Instrument Panel |
| 24 | Dozer Lever (Optional) |
| 25 | Fuel Heater Switch (Optional) |
| 26 | Overload Warning Switch (Optional) |
| 27 | Safety Lever |

1. Starter Switch

A three-position starter switch is used to start or stop engine for equipment operation.

- O. Turning switch to this position turns engine "OFF" with its electrical system. In this position engine is "OFF" but interior cabin light and fuel tank transfer pump (if equipped) are functional.
- I. Turning switch to this position turns engine electrical system "ON". When switch is first turned "ON" the six indicator/warning lights across top of instrument panel, will light for approximately two seconds. The battery warning light and engine oil pressure warning light should remain "ON" after the other four have turned "OFF".

NOTE: *Preheat Indicator Light - The operation of the preheat cycle depends on coolant temperature. When the engine coolant is cold enough, the preheat indicator light will remain "ON" until engine preheat cycle is completed. The preheat cycle takes about twenty seconds to complete, and the indicator light will turn "OFF". When the light turns "OFF", engage the starter.*

- Ⓞ. Moving switch to this position will crank engine. When engine starts, release key and allow it to return to "I" (ON) position. Do not operate the starter switch for more than fifteen seconds at a time. This will help prevent damage to starter.

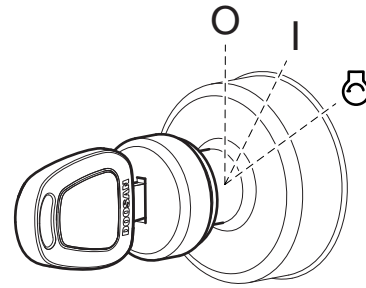

Figure 4

FG000014



WARNING

AVOID DEATH OR SERIOUS INJURY

DO NOT USE STARTING FLUIDS. The preheat system could cause the starting fluid to explode. Starting fluids should never be used.

2. Engine Speed Control Dial

The engine speed is controlled by the dial. Rotating it clockwise increases engine speed (rpm) and counterclockwise decreases engine speed.

- A Low idle (Lowest engine speed)
- B High idle (Highest engine speed)

NOTE: *The auto idle system will automatically reduce engine speed to idle speed approximately four seconds after all of the control levers are in the neutral position. This system is designed to reduce fuel consumption and noise. See "3. Auto Idle Selector Button" on page 2-32.*

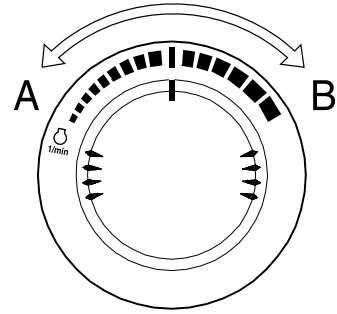



Figure 5

HAOA690L

3. Quick Coupler Switch (Optional)

Clamp releasing for dispensable attachment is controlled.

- O. In this position , the quick coupler is "LOCKED". The attachment is secured to the arm.
- I. In this position , the quick coupler is "UNLOCKED". The attachment is released from the arm.

NOTE: *To move the switch, pull up on the toggle and then move it into "UNLOCKED" position.*

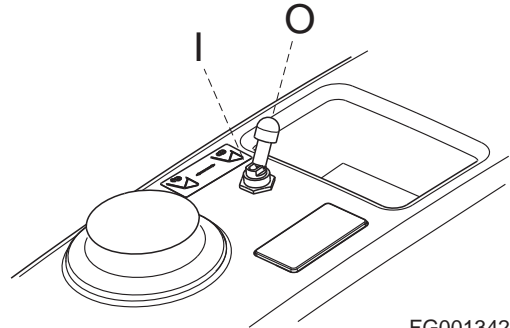



Figure 6

FG001342



WARNING

AVOID DEATH OR SERIOUS INJURY

When the attachment is still connected to the machine, while the switch is "I" () position, do not operate the machine or the attachment might fall to the ground. It would cause personnel injuries.

4. Auxiliary Mode Switch

When the control system is out of order, the pump system can be controlled manually.

- O. In this position, the manual pump control is "OFF".
- I. In this position, the manual pump control is "ON".



CAUTION

AVOID INJURY

Be sure to turn pump control to "O" (OFF) position, after the control system is operating properly.

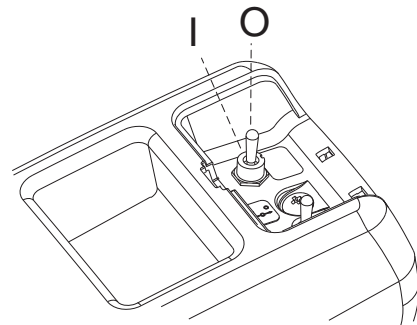

Figure 7

FG001343

5. Engine Emergency Stop Switch

If the engine does not stop when using the starter switch, it can be stopped by moving the engine emergency stop switch to "I" (EMERGENCY STOP) position.

- O. In this position, the engine emergency stop system is "OFF".
- I. In this position, "EMERGENCY STOP" is selected. The engine will stop.

NOTE: *When released, the switch will return to its original position "O" (OFF) position.*

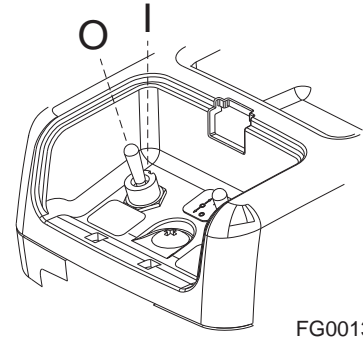

FG001344

Figure 8

6. Audio Control Panel

The audio system can be remotely controlled using this panel.

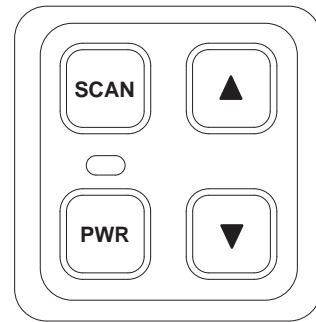

FG000018

Figure 9

Each time this power button is pressed, the audio system is turned either "ON" or "OFF".

If the audio system turns "ON", an indicator light above the button turns "ON".



FG000019

Figure 10

Press the up button, to "INCREASE" volume.

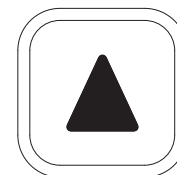

FG000020

Figure 11

Press the down button, to "DECREASE" volume.



FG000021

Figure 12

Manual Scan: When pressing scan button once, for less than half-a-second, the frequency will be moved up in sequence to the next available signal.

Auto Scan: When pressing scan button for more than a half-a-second, the frequencies are automatically scanned to the next higher one and will continue until button is again pressed to stop the scan.



FG000022

Figure 13

7. Travel Speed Selector Switch



WARNING

AVOID DEATH OR SERIOUS INJURY

Do not operate the travel speed selector switch when unit is in motion. Temporary loss of control could result.

This switch activates the automatic speed range for travel.

- O. In this position, "LOW" travel speed is selected.
- I. In this position, "HIGH" travel speed is selected.
- II. In this position, "AUTOMATIC" travel speed is selected. The travel speed automatically changes between "LOW" or "HIGH" range, depending on engine speed and travel motor loads.

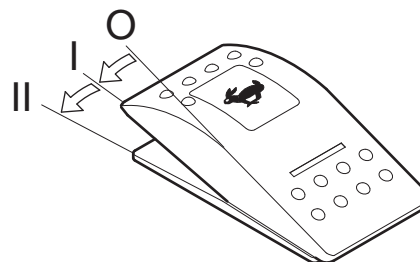

FG000023

Figure 14

8. Light Switch

This switch is used to turn "ON" the lights.

- O. In this position, all lights are "OFF".
- I. In this position, all illumination lights of the instrument panel and the control switches are turned "ON".
- II. In this position, all illumination lights and work lights are turned "ON".



CAUTION

AVOID INJURY

Do not leave instrument panel or work lights "ON" when the engine is not running. Leaving lights "ON" with the engine stopped will discharge batteries.

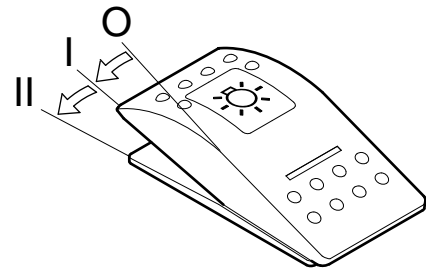

FG000024

Figure 15

9. Breaker/Boost/Shear Selector Switch

This switch is used to either select the breaker, power boost, or shear.

- O. In this position, a hydraulic pressure rise will be activated when pressing the button on the right-hand work lever (joystick).
- I. In this position, shear is activated.
- II. In this position, breaker is activated.



CAUTION

AVOID INJURY

Before using any attachment in a work application, be sure to check its functional control. Make sure that desired movement or action is being activated by the control. e.g. opening/closing, CW/CCW, crowd/dump, etc.

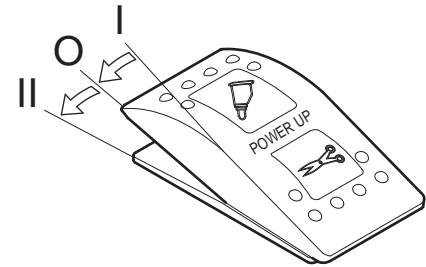

FG000025

Figure 16

10. Cabin Work Light Switch (Optional)

This switch is used to control the cabin work lights, if unit is equipped with them.

- O. In this position, all cabin work lights are turned "OFF".
- I. In this position, the front cabin work lights on the front top of cabin will turn "ON".
- II. In this position, the front cabin work lights on the front top of cabin and rear cabin work lights on rear top of cabin will turn "ON".

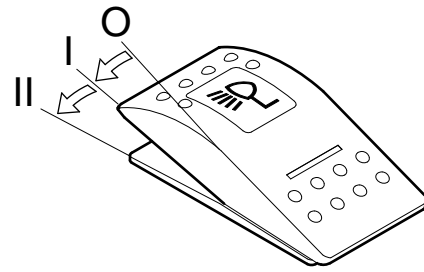

FG000026

Figure 17

11. Warning Light Switch (Optional)

If unit is equipped with a warning light, push this switch to activate it.

- O. In this position, the warning light is turned "OFF".
- I. In this position, the warning light turns "ON" and will start flashing.

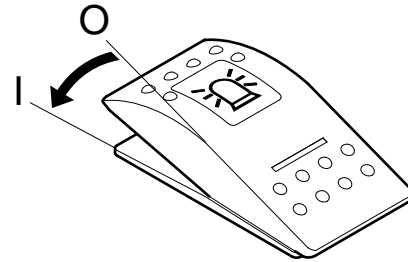

FG000027

Figure 18

12. Heater and Air Conditioner Control Panel

This panel is used to control air conditioner and heater in operator's cabin. Refer to "Heater and Air Conditioner Control Panel" on page 2-48 for more details.

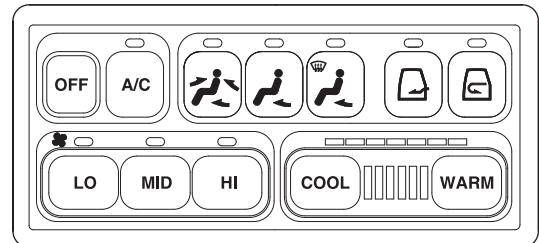

FG014507

Figure 19

13. Wiper Switch Panel

This panel is only for operation of the upper windshield wiper. When the wiper stops running, it moves to right side of the cabin, resting in its support.

NOTE: *When the front window is lifted, the wiper motor will not operate.*

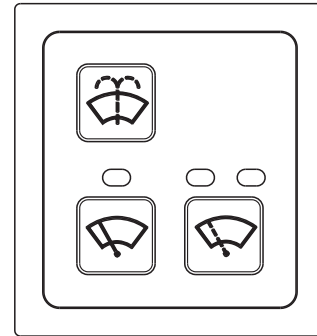

FG000308

Figure 20

Constant Speed Button

Pressing the button turns "ON" the windshield wiper. An indicator light above the button will turn "ON" indicating that wiper is "ON". The wiper will run at a constant speed.

Pressing the button again, turns "OFF" the windshield wiper.

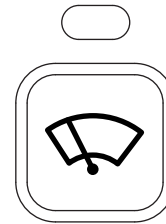

FG000241

Figure 21

Intermittent Speed Button

Pressing button once (first time):
Windshield wiper runs approximately on a three second intermittent cycle. The left side indicator light will turn "ON".

Pressing button again (second time):
Windshield wiper runs approximately on a six second intermittent cycle. The right side indicator light will turn "ON".

Pressing button again (third time):
Turns "OFF" the windshield wiper. Both indicator lights will be turned "OFF".

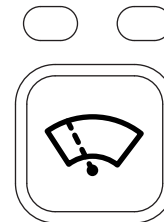

FG000242

Figure 22

Windshield Washer Button

Pressing the washer button will spray windshield washer fluid onto the windshield. Use only the proper windshield washer fluid in the system.

NOTE: *Do not operate the windshield washer without any fluid. If operate without any fluid, the washer motor may be damaged. Check level in washer tank, and add fluid as required.*

NOTE: *Using soapy water or synthetic detergent instead of window cleaning fluid, can damage the wiper blade or painted surfaces. Use standard window cleaning fluid: SSK703.*



FG000243

Figure 23

14. Power Socket for 12 Volt

This is a power socket for only 12V DC devices.

This socket can be used for charging a cellular phone or powering a small 12V DC electrical device.

Open the cap when using it.

NOTE: *This socket is designed for small electrical capacity devices. Do not use this socket for large electrical capacity devices. Thus, damage can be avoided.*

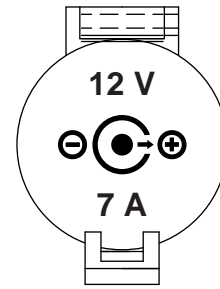

FG017015

Figure 24

15. Cigarette Lighter

Push the lighter all the way into the socket and release your hand. After pushing it in, it will be ejected when it is heated. If it does not eject after a short time, pull it out and have it serviced.

NOTE: *This cigarette lighter is for 24V only. Never connect a 12V electrical device to the lighter.*

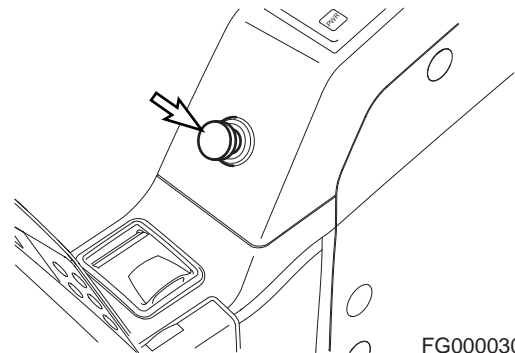

FG000030

Figure 25

16. Seat Warmer Switch (Optional)

If the seat is equipped with the optional seat warmer, push this switch to activate it.

When the seat is warmed, the warmer is automatically turned "OFF".

- O. In this position, the seat warmer is turned "OFF".
- I. In this position, the seat warmer is turned "ON".

NOTE: *The starter switch must be "ON" with the engine running, for the heater to operate.*

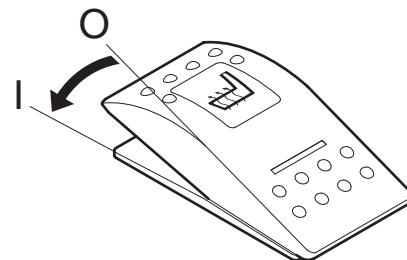

FG000034

Figure 26

17. Travel/Swing Alarm Switch (Optional)

If unit is equipped with a travel/swing alarm buzzer, push this switch to active it, whenever swinging or traveling.

- O. In this position, the travel/swing alarm system is turned "OFF".
- I. In this position, the travel alarm will only sound, when the machine is moving.
- II. In this position, the travel/swing alarm will sound while swinging and traveling, if equipped with a swing alarm device.

NOTE: *If machine is only equipped with a travel alarm device, the alarm will not sound when swinging although the switch is in the "II" position.*

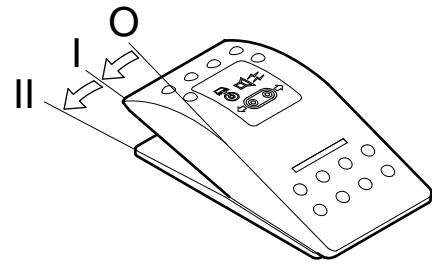

FG000031

Figure 27

18. Horn Button (Left-hand Work Lever)

Press the lower button on the top of the left-hand work lever (joystick) to sound horn.

NOTE: *The starter switch must be "ON".*

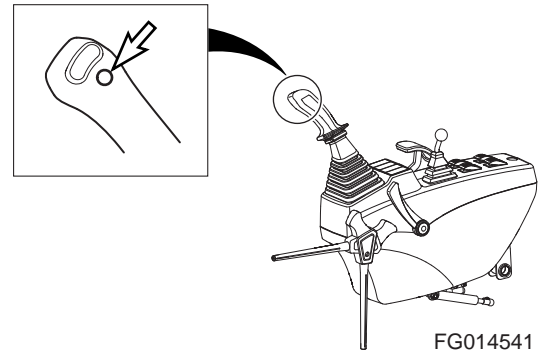

FG014541

Figure 28

19. Rotating Buttons

For a machine equipped with an attachment that rotates, press the upper two buttons on the top of the left-hand work lever (joystick) to rotate the attachment clockwise or counterclockwise. Left button is for counterclockwise and the right one is for clockwise.



CAUTION

AVOID INJURY

Before using any attachment in a work application, be sure to check its functional control. Make sure that desired movement or action is being activated by the control. e.g. opening/closing, CW/CCW, crowd/dump, etc.

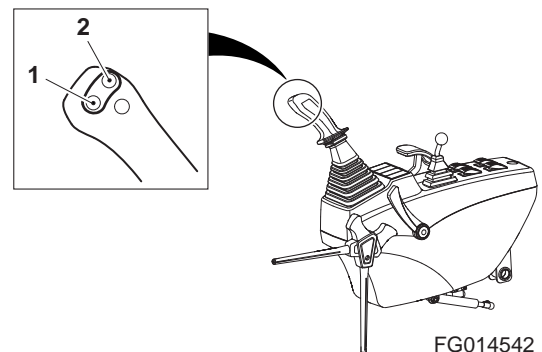

FG014542

Figure 29

20. Travel Lever

21. Shear Buttons

For a machine equipped with shear, press the two upper buttons on the top of the right-hand work lever (joystick) to open or close the shear. Left button is for closing (crowd), right button is for opening (Dump).

NOTE: *These buttons work with the breaker/boost/shear selector switch. See "9. Breaker/Boost/Shear Selector Switch" on page 2-12.*



CAUTION

AVOID INJURY

Before using any attachment in a work application, be sure to check its functional control. Make sure that desired movement or action is being activated by the control. e.g. opening/closing, CW/CCW, crowd/dump, etc.

22. Booster Button (Right-hand Work Lever)

Press the lower button on the top of the right-hand work lever (joystick) to boost the hydraulic pressure. Refer to the "Boost Mode" on page 3-21.

NOTE: *This button works with the breaker/boost/shear selector switch. See "9. Breaker/Boost/Shear Selector Switch" on page 2-12.*

23. Instrument Panel

See "Instrument Panel" on page 2-19.

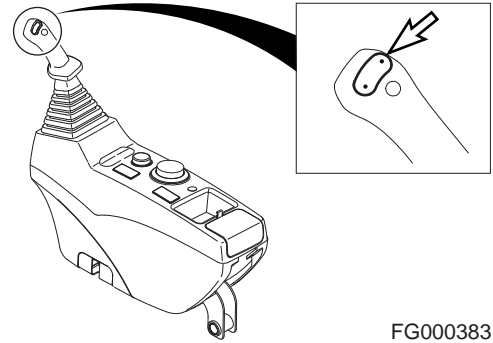

Figure 30

FG000383

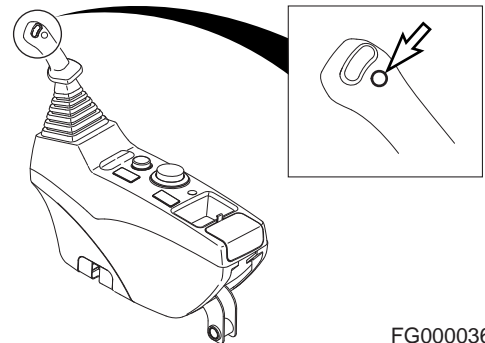

Figure 31

FG000036

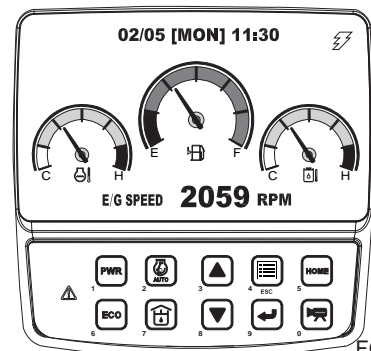

Figure 32

FG013662

24. Dozer Lever

25. Fuel Heater Switch (Optional)

This switch is used to activate the fuel heater system. When the switch is activated, the fuel is warmed, depending upon the temperature of the fuel.

NOTE: *If the fuel temperature is above 5°C (41°F), heating system is not activated.*

O. In this position, the fuel heater system is turned "OFF".

I. In this position, the fuel heater system is turned "ON".

NOTE: *The starter switch must be "ON".*

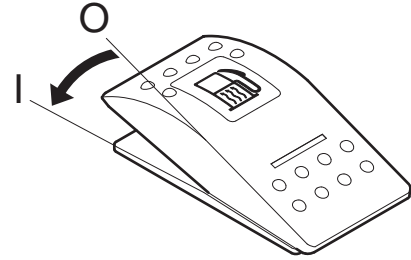

FG000033

Figure 33

26. Overload Warning Switch (Optional)

If unit is equipped with an overload warning device, push this switch to activate it.

O. In this position, the overload warning device is turned "OFF".

I. In this position, when a load is lifted that reaches the machine safe lifting limit, a warning light on the instrument panel will turn "ON" and a warning buzzer will sound.

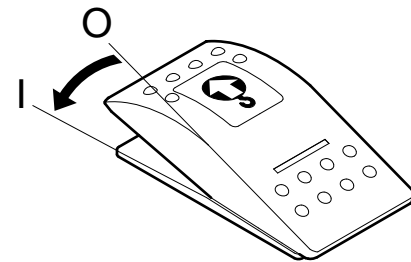

FG000032

Figure 34



WARNING

AVOID DEATH OR SERIOUS INJURY

To prevent injury, do not exceed the rated load capacity of the machine. If the machine is not on level ground, load capacities will vary. There may be local government regulations about the use of excavators for lifting objects. Please observe these regulations.

27. Safety Lever

See "Safety Lever" on page 3-12.

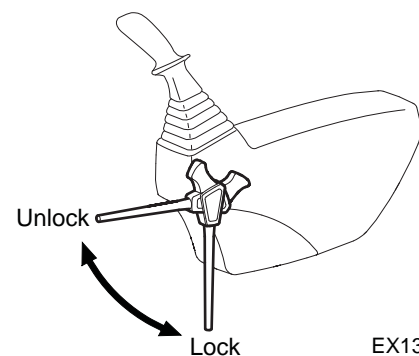

EX1300566

Figure 35

INSTRUMENT PANEL

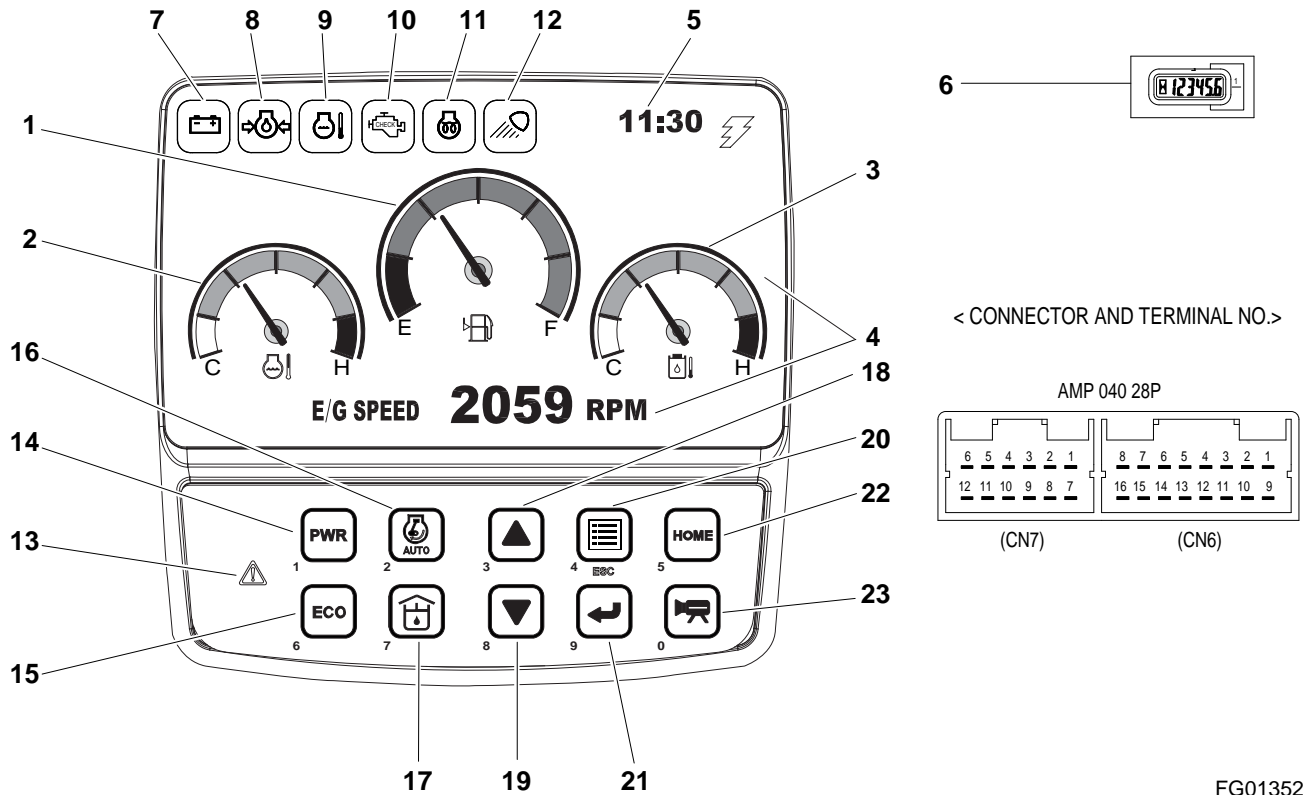

Figure 36

FG013521

| Reference Number | Description |
|------------------|--|
| 1 | Fuel Gauge |
| 2 | Engine Coolant Temperature Gauge |
| 3 | Hydraulic Oil Temperature Gauge |
| 4 | Multifunction Gauge and Graphic Information Area (See page 2-25) |
| 5 | Digital Clock |
| 6 | Hour Meter |
| 7 | Charge Warning |
| 8 | Engine Oil Pressure Warning |
| 9 | Engine Coolant Temperature Warning |
| 10 | Engine Check Warning |
| 11 | Preheat Indicator |
| 12 | Work Light Indicator |
| 13 | Warning Light |

| Reference Number | Description |
|------------------|--|
| 14 | Power Mode Selector Button (See page 2-31) |
| 15 | Economy Mode Selector Button (See page 2-31) |
| 16 | Auto Idle Selector Button (See page 2-32) |
| 17 | Flow Control Button (See page 2-32) |
| 18 | Up Arrow Button (See page 2-33) |
| 19 | Down Arrow Button (See page 2-34) |
| 20 | Display Selector Button (See page 2-34) |
| 21 | Selection Button (See page 2-34) |
| 22 | Home Selector Button |
| 23 | Camera Selector Button |

Functional check

When the engine starter switch is turned to "I" (ON) position, all gauge bands, switch/button indicator lights and warning lights will turn "ON" and the alarm buzzer will sound about two seconds.

During this functional check, a LOGO will appear on the multifunction gauge in the graphic information area (3 and 4, Figure 36).

Password Activated

If a password has already been set and the system has been "LOCKED", the password display will appear on the screen once the functional check has been completed. Enter the password into the text area and then engage the starter.

NOTE: Refer to "Set Password (Lock and Unlock)" on page 2-41, for further details.



AVOID INJURY

If the password does not match the stored password, the engine will not start.

1. Fuel Gauge

Shows remaining fuel quantity in tank.

BLUE ZONE (■) - Indicates a normal fuel quantity.

RED ZONE (■) - Indicates that the fuel level is low.

If the gauge pointer moves into the red zone, the fuel level symbol will turn "ON", and be display in the screen. Stop operation and immediately and add fuel.

NOTE: See "Abnormal State Warning Symbols" on page 2-27, for location of this warning symbol and others.

Check the fuel level on firm and level ground.

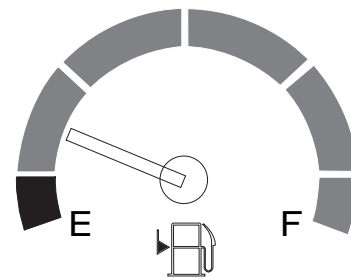

Figure 37

FG014483

2. Engine Coolant Temperature Gauge

The colored bands indicate the temperature of the engine coolant.

WHITE ZONE (□) - Indicates temperature is lower than the normal operating temperature.

BLUE ZONE (■) - Indicates temperature is within the normal operating range.

RED ZONE (■) - Indicates temperature is too high.

During operation, the pointer must be in the blue zone.

If the gauge pointer moves into the red zone, the engine coolant temperature warning light will turn "ON", a warning buzzer will sound, and the engine speed will be automatically reduced. Allow the engine to run at low idle speed until temperature gauge registers in the blue zone again. When the blue zone is reached, allow the engine to idle for an additional three - five minutes before shutting down the engine. If not allowed to idle, heat surge may develop which will damage the engine. Allowing the engine to idle will dissipate heat. Check the coolant level, look for a loose fan belt, inspect for debris around radiator, and so on.

When the temperature reaches the normal range, the engine speed will automatically recover.

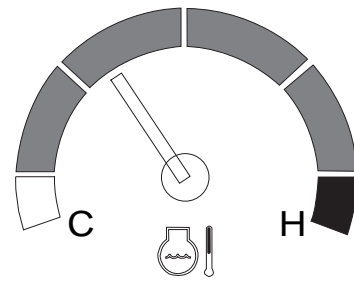

Figure 38

FG013672

3. Hydraulic Oil Temperature Gauge

The colored bands indicate the temperature of the hydraulic oil

WHITE ZONE (□) - Indicates temperature is lower than the normal operating temperature.

BLUE ZONE (■) - Indicates temperature is within the normal operating range.

RED ZONE (■) - Indicates temperature is too high.

During operation, the pointer must be in the blue zone.

If the gauge pointer moves into the red zone, the hydraulic oil temperature symbol will turn "ON", and be display in the screen. Allow the engine to run at low idle speed until temperature gauge registers in the blue zone again.

NOTE: See "Abnormal State Warning Symbols" on page 2-27, for location of this warning symbol and others.

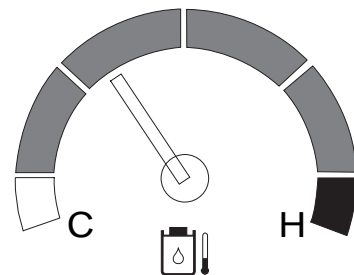

Figure 39

FG013673

4. Multifunction Gauge and Graphic Information Area

See "Multifunction Gauge and Graphic Information" on page 2-25. This section will have a more in-depth explanation of the display area.

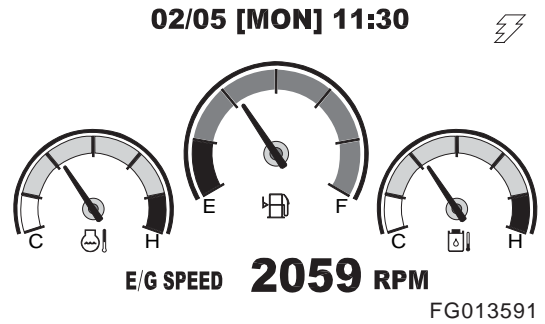

Figure 40

5. Digital Clock

A digital clock, shows the current time. The displayed contents are as follows.

| Display | Description |
|---------|-------------|
| MM | Month |
| DD | Date |
| W | Day |
| HH | Hour |
| mm | Minute |
| A (P) | AM (PM) |

MM/DD [W] HH:mm

FG000044

Figure 41

Refer to the "Setting Main Menu" on page 2-33 for time setting.

6. Hour Meter

The hour meter is used to indicate the total number of running hours on the engine. The meter will flash every four seconds when the engine is running to indicate that it is functioning properly.

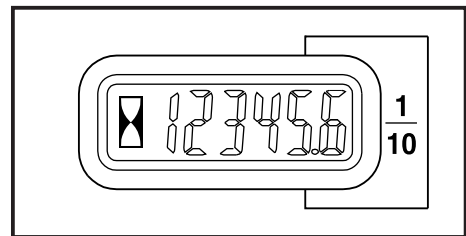

HAOA601L

Figure 42

7. Charge Warning

This symbol indicates when the engine starter switch is turned "ON", and should go "OFF" after the engine starts. If it does not turn "OFF", shut the engine down immediately and determine the cause of the problem.

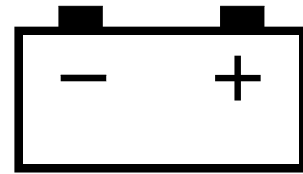

Figure 43

HAOA610L

8. Engine Oil Pressure Warning

This symbol indicates when the engine starter switch is turned "ON", and should go "OFF" after the engine starts. For example, if the engine oil pressure becomes too low, the light will turn "ON" and a warning buzzer will sound. If this happens, shut the engine down immediately and determine the cause of the problem. If you continue to work when this light is "ON", it will result in serious engine damage.

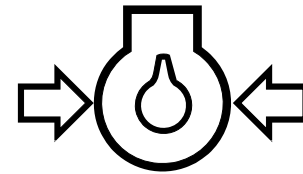

Figure 44

HAOA620L



CAUTION

AVOID INJURY

If you continue to work when this light is "ON", it will result in serious engine damage.

9. Engine Coolant Temperature Warning

If engine coolant overheats, this symbol appears on the screen an alarm will sound, and the engine speed will be automatically reduced, until coolant temperature drops. Do not turn engine "OFF" because this will cause coolant temperature to rise and can cause engine to siege because of heat surge.

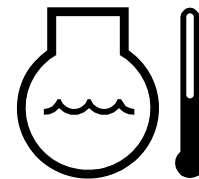

Figure 45

HAOD350L

NOTE: *Check the engine coolant temperature gauge. If the gauge pointer moves into the red zone, the engine coolant temperature warning light will turn "ON", a warning buzzer will sound, and the engine speed will be automatically reduced. Allow the engine to run at low idle speed until temperature gauge registers in the blue zone again. When the blue zone is reached, allow the engine to idle for an additional three - five minutes before shutting down the engine. If not allowed to idle, heat surge may develop which will damage the engine. Allowing the engine to idle will dissipate heat. Check the coolant level, look for a loose fan belt, inspect for debris around radiator, and so on.*

When the temperature reaches the normal range, the engine speed will automatically recover.

10. Engine Check Warning

This symbol indicates when the engine needs to be checked.

NOTE: *If this symbol turns "ON" stop the machine and repair the cause of the fault.*

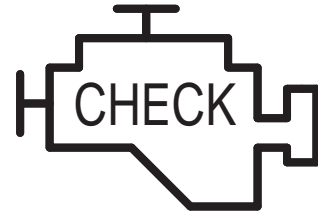

Figure 46

FG000045

11. Preheating Indicator

In cold weather this symbol indicates that engine preheat function is operating.

When this indicator symbol turns "OFF", it means that engine preheat cycle has been completed.

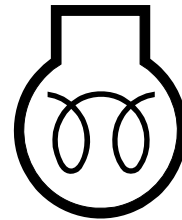

Figure 47

HAAE2000

12. Work Light Indicator

The indicator symbol indicates that work lights are turned "ON".



Figure 48

HB4O2003

13. Warning Light

This warning light appears when the machine or engine needs to be checked.

NOTE: *If warning light appears, Stop the machine and repair the cause of the fault*

If camera mode is being used, Move to the main screen and check the fault



Figure 49

FG017012

MULTIFUNCTION GAUGE AND GRAPHIC INFORMATION

When the engine starter switch is turned to "I" (ON) position, a LOGO will appear on the display screen for about two seconds.

When the LOGO disappears, the multifunction gauge and graphic information screen will appear.

The engine rpm is normally displayed at the bottom of the screen when the starter switch is first turned "ON". Each time the display selector button (19, Figure 36) is pressed, the digital readout changes in the following sequence; Engine speed (rpm) -> Battery voltage (VOLT) -> Front pump pressure (BAR) -> Rear pump pressure (BAR).

NOTE: See Figure 53 thru Figure 56.

A digital clock is located at the top of the display.

By using a combination of the mode selector buttons, information for filters and oils can also be displayed.

The display can also be set for the desired language.

Refer to the "Setting Main Menu" on page 2-33 for the language selection and information display sequences.

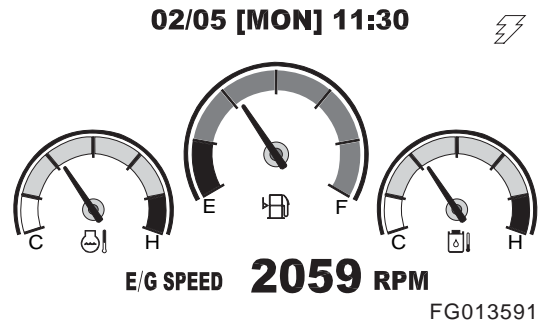

Figure 50

Communication Indicator

Indicates the condition of communication between main controller and instrument panel.

1. Normal Condition:

The symbol will sequentially move like lightening.

NOTE: See Figure 53 thru Figure 56.

2. Abnormal Condition:

If the symbol is not displayed, it means there is a communication error.

NOTE: See Figure 52.

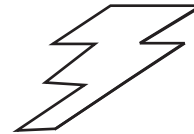

Figure 51

FG000047

Communication Error Warning

If a communication error is generated between EPOS controller and instrument panel, this symbol will be displayed.

When this symbol is displayed, contact a DOOSAN distributor or sales agency.

NOTE: *If a communication error occurs during operation, the last mode setting is stored. e.g. power mode, work mode and auto idle are stored during failure.*

NOTE: *When starter switch is turned to "I" (ON) position during a state of communication error failure, the EPOS controller will default to the following modes.*

Power mode: Standard mode

Working mode: Digging mode

Auto idle: "ON" (Selection state)

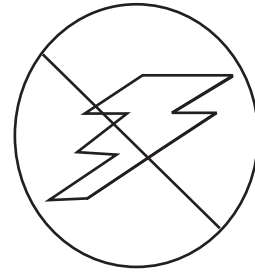

FG000048

Figure 52

Engine Speed

The engine speed is numerically displayed.

E/G SPEED 1700 RPM

FG000049

Figure 53

Battery Voltage

The battery voltage is numerically displayed. With the engine running, the reading must be between 26V - 30V.

When the starter is engaged or the preheat system is being used, the voltage can temporarily drop below 24V, but this is a normal condition.

BATTERY 28.0 VOLT

FG000050

Figure 54

Front Hydraulic Pump Pressure

The front pump pressure is numerically displayed.

NOTE: *This pump is closest to engine flywheel housing or is the upper one of hydraulic pump.*

It displays the reading in BARs.

FRONT PUMP 320 BAR

FG000051

Figure 55

Rear Hydraulic Pump Pressure

The rear pump pressure is numerically displayed.

NOTE: *This pump is the farthest from engine flywheel housing or is the lower one of hydraulic pump.*

It displays the reading in BARs.

REAR PUMP 313 BAR

FG000052

Figure 56

Abnormal State Warning Symbols

1. Hydraulic Oil Overheating Warning
2. Fuel Shortage Warning
3. Return Filter Clogged Warning
4. Air Cleaner Clogged Warning
5. Overload Warning (Optional)
6. Water in fuel Warning

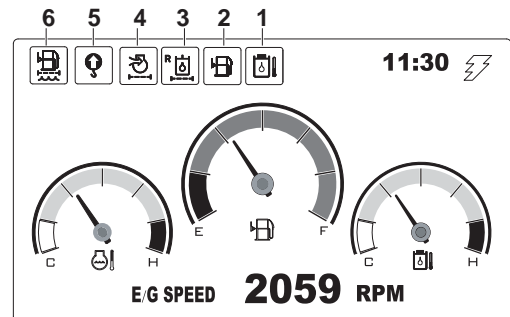

DS1801626

Figure 57

Examples of Warning Display

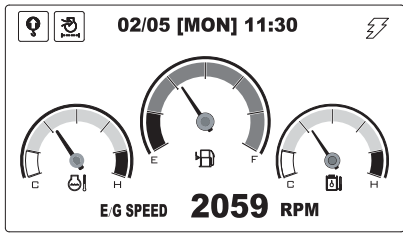

FG013703

<2 kinds of warning display>

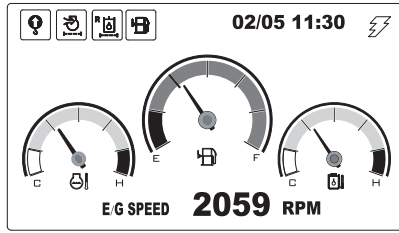

FG013704

<4 kinds of warning display>

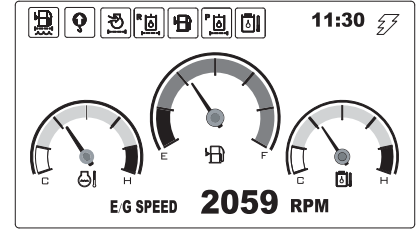

FG013705

<7 kinds of warning display>

Figure 58

1. Hydraulic Oil Overheat Warning

If the hydraulic oil temperature is too high, this symbol appears on the screen.

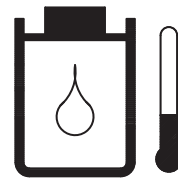

FG000056

Figure 59

2. Fuel Shortage Warning

If the fuel quantity is too low, this symbol appears on the screen.

If this light turns "ON", add fuel as soon as possible.

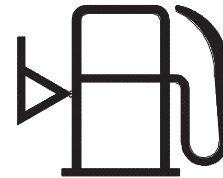

FG000057

Figure 60

3. Return Filter Clogged Warning

This symbol indicates when the hydraulic return filter is clogged.

If this symbol is displayed, immediately stop operation and replace the return filter.

After the return filter has been serviced, restart machine operation to remove warning symbol.

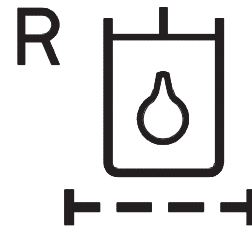

FG000054

Figure 61

4. Air Cleaner Clogged Warning

This symbol indicates when the air cleaner is clogged.

If this symbol is displayed, immediately stop operation and replace or clean the air filter.

After the air filter has been serviced, restart machine operation to remove warning symbol.

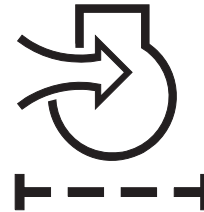

FG000053

Figure 62

5. Overload Warning (Optional)

If the overload warning switch is turned "ON", and this symbol appears on the screen and the warning buzzer sounds, that indicates that overloaded condition is occurring. Immediately reduce the load.



AVOID DEATH OR SERIOUS INJURY

If this warning appears on the screen and a warning buzzer sound, reduce the load immediately.

If you continue to work, the machine can be turned over or damage to hydraulic components and structural parts could occur.

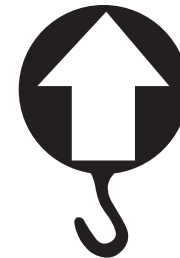

FG000253

Figure 63

6. Water In Fuel Warning

This symbol indicates when the water is full in the fuel prefilter

When this symbol appears drain the water from the fuel prefilter as soon as possible.

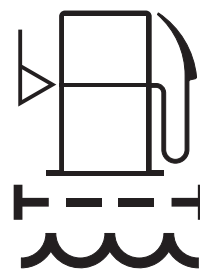

Figure 64

FG013744

MODE SELECTOR BUTTONS

1. Power Mode Selector Button
2. Economy Mode Selector Button
3. Auto Idle Selector Button
4. Flow Control Button



FG013707

Figure 65

1. Power Mode Selector Button

This power mode is suitable for heavy-duty work that requires a high operating speed. Push this button to turn power mode "ON" or "OFF".

When the power mode button is pushed to "ON" position, an indicator light above it turns "ON".

When the power mode button is pushed again, it is turned "OFF" and the power mode is deactivated and returns to the standard operating mode.

When turning the engine starter switch to "I" (ON) position, the power mode is automatically defaulted to "Standard Mode".

NOTE: For further details, see "Mode Selection" on page 3-19.



FG013709

Figure 66

2. Economy Mode Selector Button

Economy mode is used for light loading work, when this mode selected it will reduce noise and fuel consumption with standard mode.

When the economy mode button is pushed to "ON" position, a symbol appears on the screen.

NOTE: When the economy mode button is pushed again, it is turned OFF and the economy mode is deactivated and returns to the standard operating mode.



FG013710

Figure 67

3. Auto Idle Selector Button

When the auto idle system is activated, the engine will automatically reduce speed to "IDLE" approximately four seconds after all of the control levers are in the neutral position. This system is designed to reduce fuel consumption and noise.

When the auto idle selector button is pushed to "ON" position, an indicator light above it turns "ON".

When the auto idle selector button is pushed again, it is turned "OFF" and the engine speed will return to the setting of the engine speed dial and will remain at this speed despite control lever position, until engine speed dial is moved.



2

Figure 68

FG013711

4. Flow Control Button

When the button is pushed, you can control the hydraulic oil flow rate.

The flow control button is used to set the flow rate of pump to match the installed tool/attachment for optimal performance, without damaging it.

NOTE: For further details, see "Flow Control" on page 2-43.



7

Figure 69

FG013896

SETTING MAIN MENU

By using a combination of the selector buttons (Figure 71), you can review and set the contents of the display screen. Items such as language, time and filter/oil information can be checked, and if necessary, set with new information.

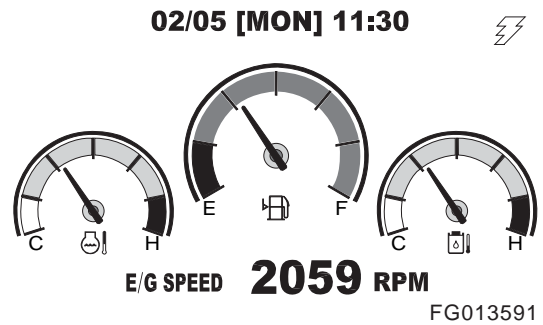

Figure 70

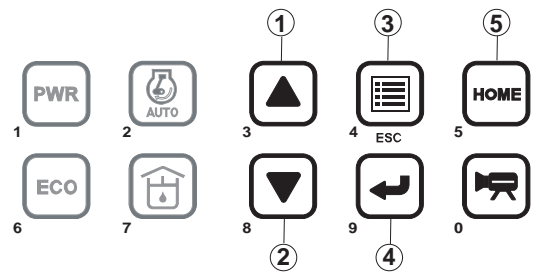

Figure 71

1. Up Arrow Button

Up arrow button (▲), is used to move a menu item "Up" or to "Left".



Figure 72

2. Down Arrow Button

Down arrow button (▼), is used to move a menu item "Down" or to "Right".



Figure 73

FG013897

3. Display Selector Button (ESC - Escape)

Display selector button (☰), is used to change the displayed information on the screen. Each time the display selector button is pressed, the digital readout changes.

NOTE: When setting the main menu, this button is used as the menu/exit button (ESC). To access the menus the button must be pressed and held for three seconds.

NOTE: When this button is used for menu/exit button, it is used to access to main menu or return to a previous screen from each submenu.



Figure 74

FG000070

4. Selection Button

Selection button (↩), is used to set a menu or clear the operating hour of filter/oil.

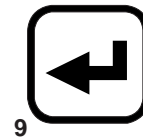

Figure 75

FG013898

5. Home Button

Home button (HOME), is used to access to the default screen from each submenu.



Figure 76

FG013713

Display Selection and Escaping

Display Selection

When the display button is pressed for more than three seconds, the main menu screen (Figure 79) is displayed.

In the normal display screen, the engine speed (rpm), battery voltage (volt), front pump pressure (bar), and rear pump pressure (bar) can be displayed.

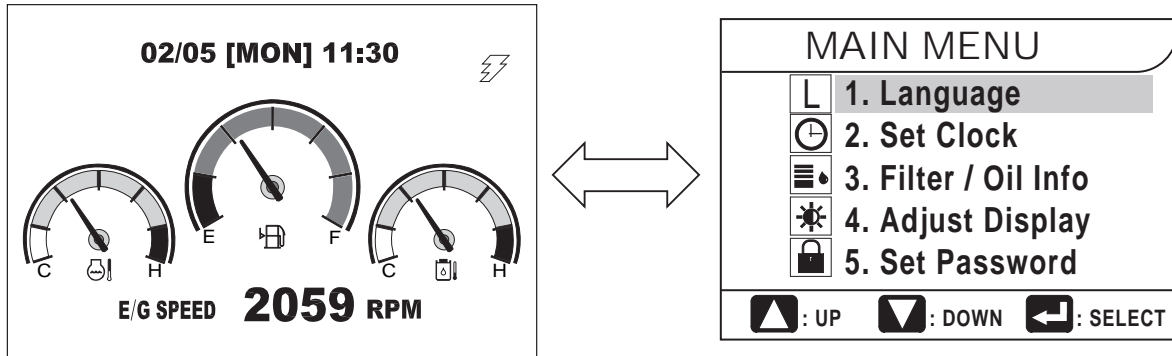



Figure 77

FG015019

ESC Button

The screen will return from the main menu to the normal display screen, by again pressing the "ESC" () button.

NOTE: *If more than twenty seconds are spent in any menu, without changing the screen, it will return to the normal display screen.*

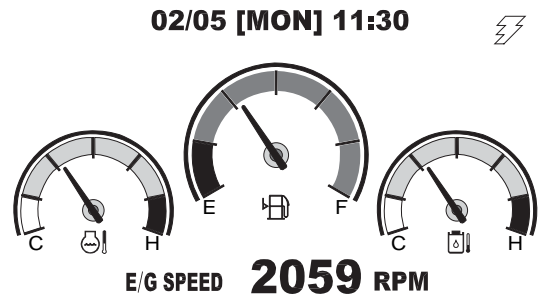

Figure 78

FG013591

Main Menu

The menu selection can be changed by pressing the "UP" (▲) or "DOWN" (▼) buttons. The selected menu item will be highlighted, and a cursor will appear by the menu item.

When the selected menu item is highlighted, press the "SELECT" (↵) button to enter the next submenu.

1. "Language" on page 2-37.
2. "Set Clock" on page 2-37.
3. "Filter/Oil Info" on page 2-38.
4. "Adjust Display" on page 2-40
5. "Set Password (Lock and Unlock)" on page 2-41

Language

When the cursor is on "Language", press the "SELECT" (↵) button. The language submenu will appear.

The desired language can be selected by using the "UP" (▲) or "DOWN" (▼) buttons.

The display can be set for the desired language.

Press the "SELECT" (↵) button to set the selected language.

NOTE: *If more than twenty seconds are spent in the menu, without changing the screen, it will return to the normal display screen.*

Set Clock

When the cursor is on "Set Clock", press the "SELECT" (↵) button. The set clock submenu will appear.

NOTE: *If more than twenty seconds are spent in the menu, without changing the screen, it will return to the normal display screen.*

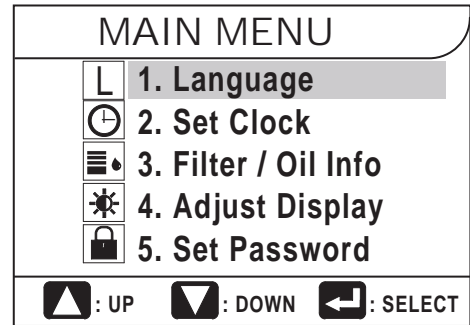

FG013563

Figure 79

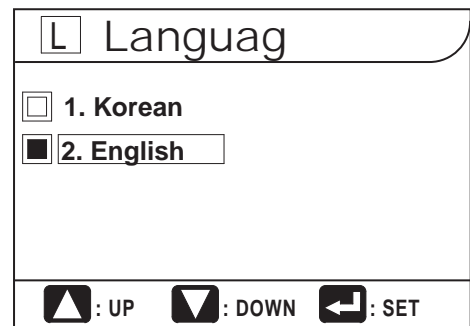

FG013564

Figure 80

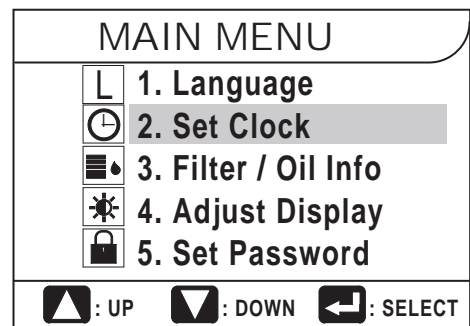

FG013565

Figure 81

Setting Method

1. Move the cursor to desired number by using the "SELECT" (←) button. When selected the number will flash.
2. Set the time by using the "UP" (▲) or "DOWN"(▼) buttons.
 - "+" (▲), "-" (▼): Increase or decrease number.
 - "MOVE" (←): Confirm and move the cursor to next number.
 - "ESC" (☰): Exit to the main menu.

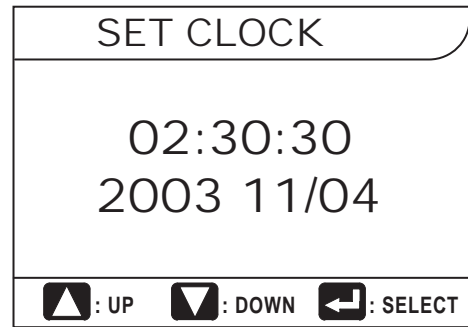

FG013566

Figure 82

'00' Minute Setting

1. Simultaneously press the "SELECT" (←) button and "UP" (▲) button.
2. If the displayed time is 30 minutes or less, the clock will display the preceding hour.
3. If the displayed time is more than 30 minutes, the clock will display the succeeding hour.
4. When the preceding hour is more than 23, the day will be increased.

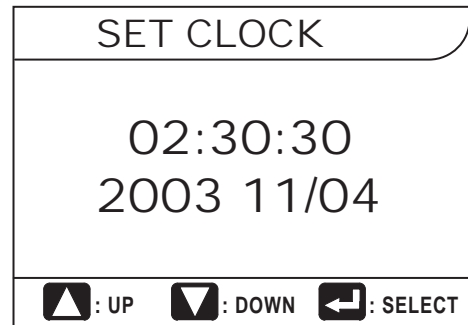

FG013566

Figure 83

Filter/Oil Info

When the cursor is on "Filter/Oil Info", press the "SELECT" (←) button. The filter/oil information submenu will appear.

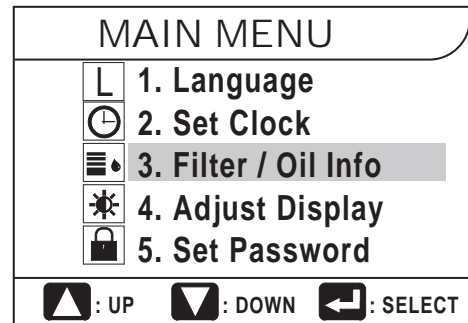

FG013567

Figure 84

Each symbol can be selected by pressing the "UP" (▲) or "DOWN" (▼) buttons. At the bottom of the screen the operating hour (Hrs) of each filter and/or oil is displayed.

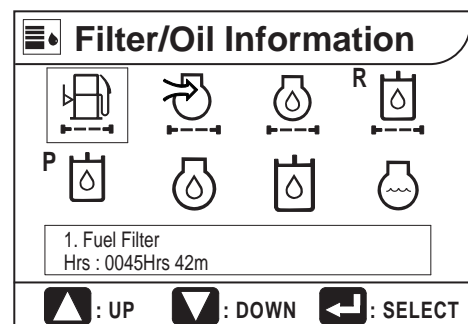

FG013568

Figure 85

Menu Display Order and Icon Explanation

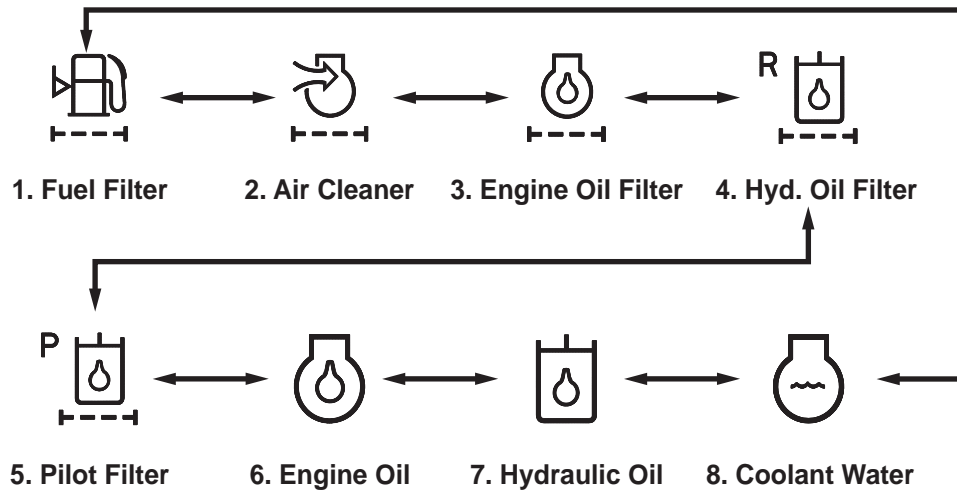

FG001358

Figure 86

Filter/Oils Operating Hour Reset

After changing a filter or oil, reset the operating hour to zero (Hrs: 0000). The next replacement period can then be easily checked. The operating hours are only accumulated while the engine is running.

On the filter/oil information screen, press the "SELECT" (↵) button and then the reset screen will be displayed.

On the reset screen, the operating hour can be changed to zero hour (Hrs: 0000) by pressing the "SELECT" (↵).

If the "SELECT" (↵) button is pressed, the reset will be completed. and the screen will be returned to the previous menu.

If the "ESC" (⏏) button is pressed, the screen will be returned to the previous menu without being reset.

NOTE: *If more than twenty seconds are spent in the menu, without changing the screen, it will return to the normal display screen.*

The screen is returned to the main menu by pressing the "ESC" (⏏) button.

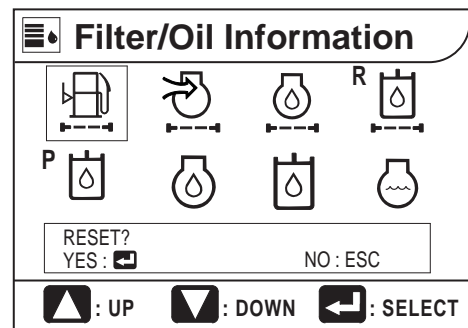

FG013716

Figure 87

Adjust Display

When the cursor is on "Adjust Display", press the "SELECT" (←) button. The adjust display submenu will appear.

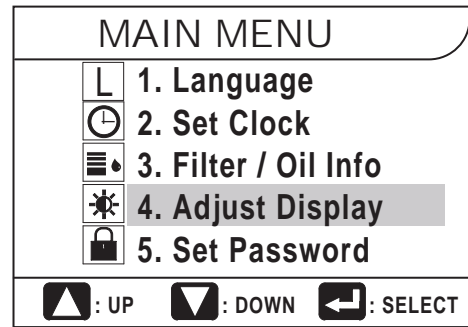

FG013569

Figure 88

When the cursor is on "Adjust Display", press the "SELECT" (←) button. The adjust display submenu will appear.

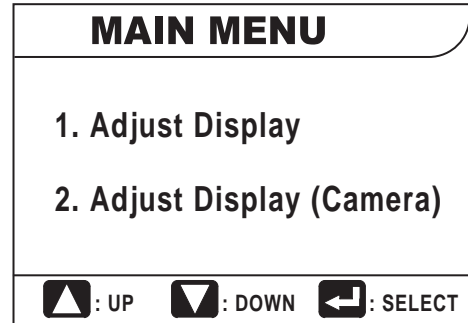

FG013835

Figure 89

1. Move the cursor to desired characteristic about display by using the "SELECT" (←) button.
2. The desired brightness, contrast, backlight adjustment can be selected by using "UP" (▲) or "DOWN" (▼) buttons.

NOTE: When the equipment shipped and it is day mode (☀), the default brightness and contrast is set to 50%, the default backlight is set to 90%.

When it is night mode (☾), the default brightness is set to 50%, the default contrast is set to 30%, the default backlight is set to 10%.

Default value of camera display is 50% (brightness), 50% (contrast), 90% (backlight).

The screen is returned to the main menu by pressing the "ESC" (☰) button. The display is then saved.

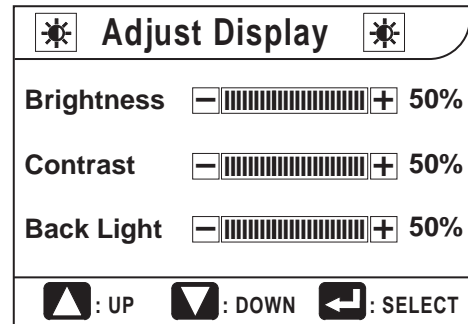

FG013570

Figure 90

Set Password (Lock and Unlock)

Use extreme care when setting the password for starting the engine. If a mistake is made when entering the number, and the number is excepted by the system, as being correct, that number will be the only one that will allow the security system to be activated or deactivated.

Write your password down and keep it in a safe location.

Password numbers can only use numbers between 1 and 0. The small number to the lower left of each button on the instrument panel, indicates the number that will be entered when that button is pressed.

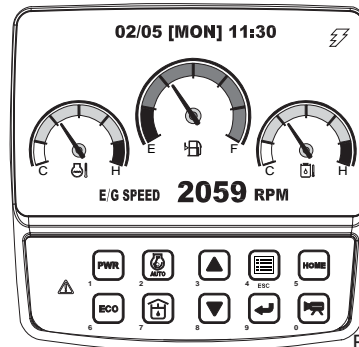

FG013662

Figure 91

When the cursor is on "Set Password" press the "SELECT" (←) button. The set password submenu will appear.

NOTE: The screen can be returned to the main menu by pressing the "ESC" (ESC) button (3, Figure 71).

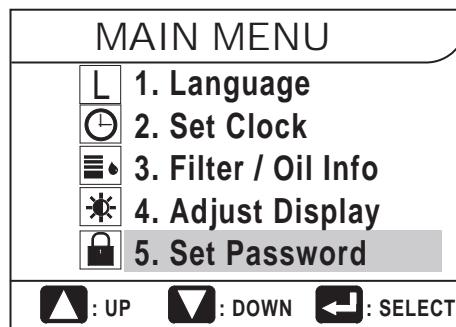

FG013571

Figure 92

Password inquiry menu will be displayed.

NOTE: The initial password is "1111".

The password can be changed within ten minutes while the starter switch is in "I" (ON) position.

After changing password, be sure to use the changed password.



CAUTION

AVOID INJURY

Failure to enter correct password three times, will return normal display screen, and another attempt will not be possible for ten minutes.



FG013717

Figure 93

A three item menu will be displayed. The items are "LOCK", "UNLOCK", and "CHANGE PASSWORD". An item can be selected by using the "UP" (▲) or "DOWN" (▼) buttons, and then selected by pressing the "SELECT" (↵) button.

Press "ESC" (⏏) button (3, Figure 71) for 1 more second, it returns to main menu.

According to the selection of adoption (lock) or nonadoption (unlock), the password function will be in working or nonworking.

When you want to change a password, follow below procedure.

1. Move the cursor to "Change Password".
2. Input desired 4 digits password using selector buttons (at the first column). Input the same password one more time (at the second column)
3. Select adoption (lock) or nonadoption (unlock) at set password menu.

NOTE: *Keep in mind never to forget password.*

NOTE: *Please contact a DOOSAN distributor, if you forget your password.*

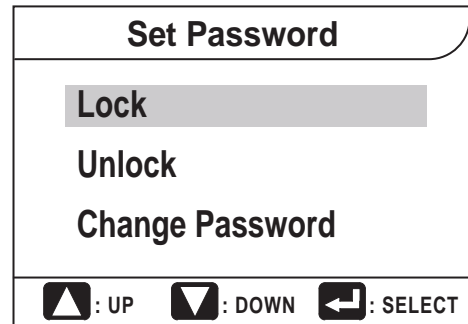

FG013718

Figure 94

FLOW CONTROL

The flow control is used to set the proper flow rate for an optional attachment (If equipped). The flow control screen is accessed directly from the normal display screen without going through the main menu or any submenus.

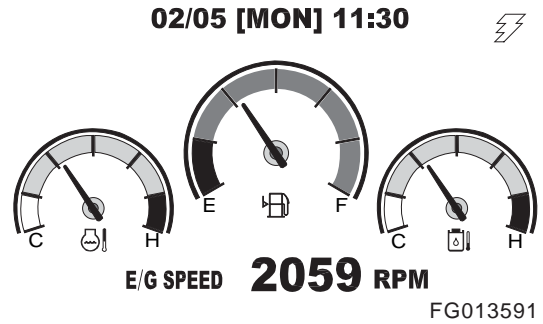

Figure 95

When the flow control button (Figure 69 and Figure 96) is pressed at the normal display screen (Figure 95), the flow control screen (Figure 98) will be displayed.



Figure 96

Select a tool by using the breaker/boost/shear selector switch. The symbol in the upper left corner of the display screen will change according to the position that the selector switch is in. Compare the symbols shown in (Figure 98 and Figure 99).

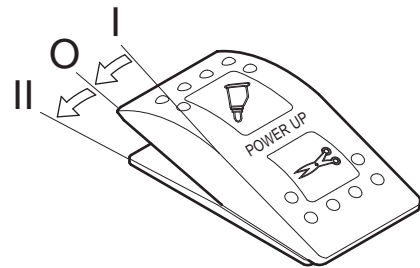

Figure 97

Adjusting Flow Rate

Use "UP" (▲) or "DOWN" (▼) buttons to adjust flow rate.

"UP" (▲) button is used to increase a flow rate.

"DOWN" (▼) button is used to decrease a flow rate.

| Flow Control Step | Pump Flow Setting (l/min) |
|-------------------|---------------------------|
| 0 | 48.5 |
| 1 | 57 |
| 2 | 66 |
| 3 | 69 |
| 4 | 78.5 |
| 5 | 90 |
| 6 | 96.5 |
| 7 | 106.5 |
| 8 | 108 |
| 9 | 114 |
| 10 | 114 |

Pump flow setting is at rated engine speed, for only the output of one pump.

Pump displacement will vary according to changes in engine rpm.

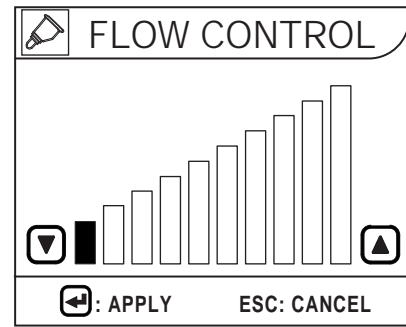

FG014885

Figure 98 Breaker

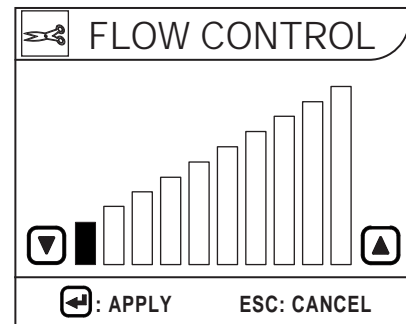

FG014886

Figure 99 Shear

Escape

- A. Press flow control button (🔒), Figure 96) to return to normal display screen and save the flow rate setting.
- B. If there is no adjustment for twenty seconds, the flow control screen will return to the normal display screen.

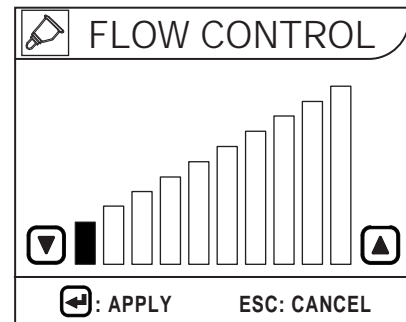

FG014885

Figure 100

OPERATION SELECTION DISPLAY

In the monitor you can see the application that is currently selected.

Power Mode Selection

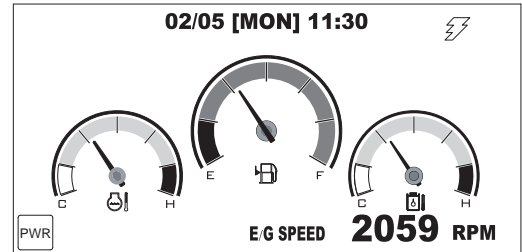

FG013720

Figure 101

Standard Mode Selection

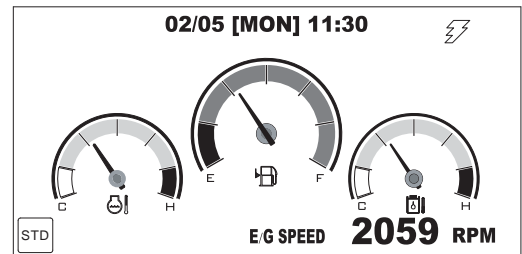

FG013721

Figure 102

Economy Mode Selection

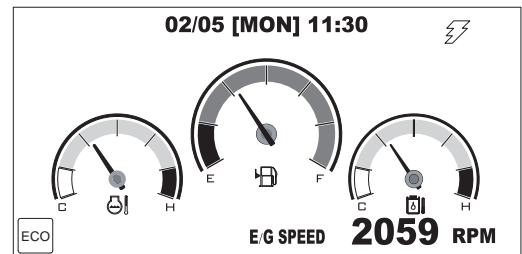

FG013722

Figure 103

Auto Idle Selection

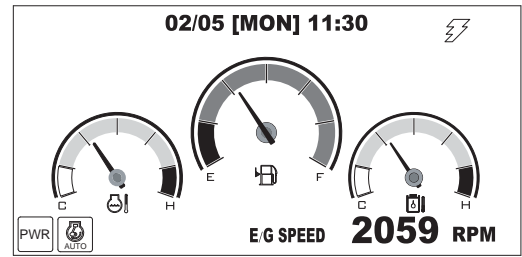

FG013723

Figure 104

Power Boost Selection

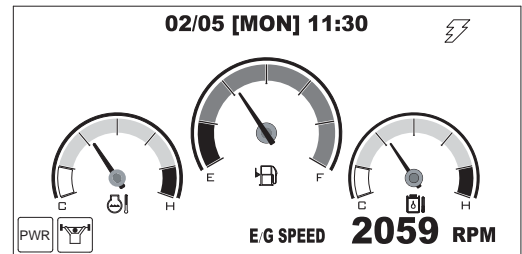

FG013724

Figure 105

Breaker Selection

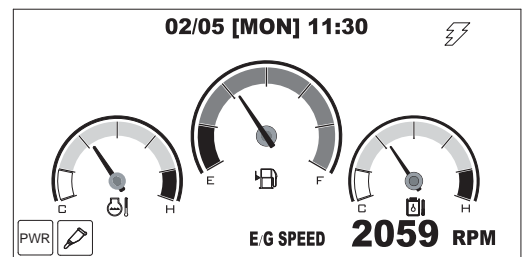

FG013725

Figure 106

Shear Selection

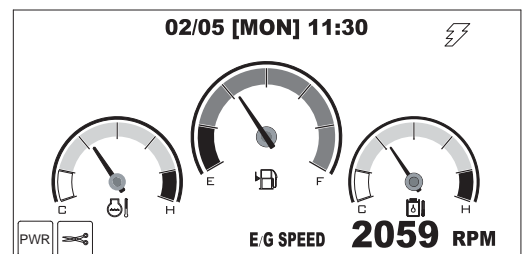

FG013726

Figure 107

Quick Coupler Operation Selection (Optional)

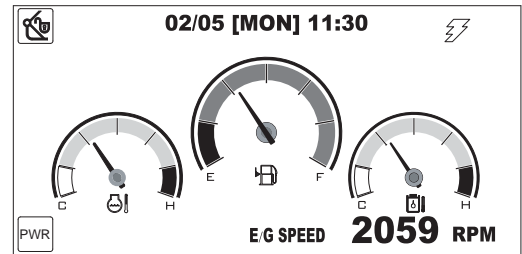

FG013728

Figure 108

Camera Mode Selector Button

Camera mode selector button (optional)

Push this button (1, Figure 109) to turn camera mode "ON" or "OFF".

When the camera mode button is pushed to "ON" position, the camera window appears on the screen.

When the camera mode button is pushed again, it is turned "OFF" and the camera mode is deactivated and return to the default screen.



FG013836

Figure 109

HEATER AND AIR CONDITIONER CONTROL PANEL

Location of Controls and Vents

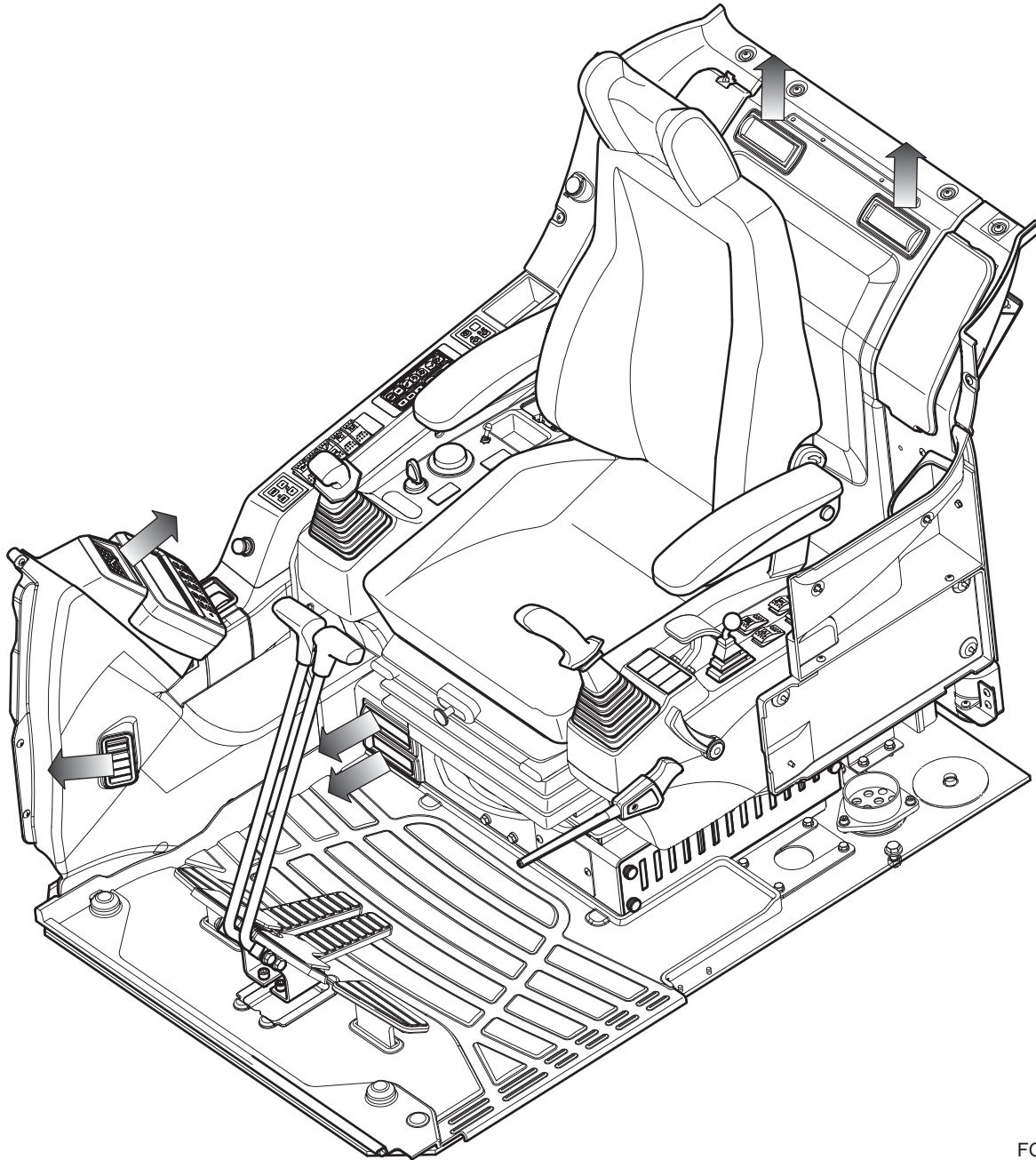

FG014384

Figure 110

The heater and air conditioner are combined into one unit under the operator's seat.

The operator can control cabin temperature using the control panel installed in the switch panel.

Control Panel

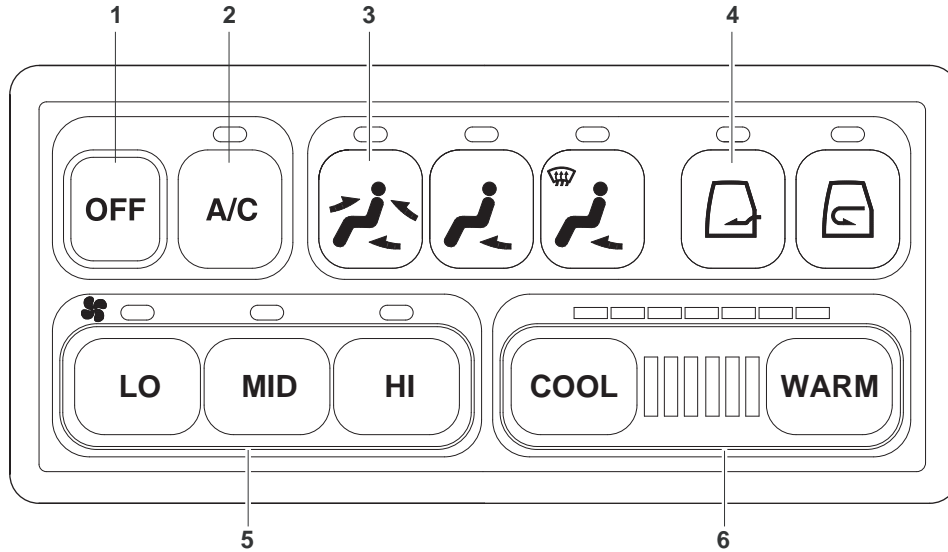

FG014376

Figure 111

| Reference Number | Description |
|------------------|--------------------------------|
| 1 | Off Button |
| 2 | Air Conditioner Control Button |
| 3 | Air Outlet Selector Button |

| Reference Number | Description |
|------------------|----------------------------|
| 4 | Air Inlet Selector Button |
| 5 | Fan Speed Selector Button |
| 6 | Temperature Control Button |

NOTE: When the light switch is turned to "I" or "II" position, the LED for illuminating in the control panel will turn "ON".

1. Off Button

This button is used to stop the fan and air conditioner.

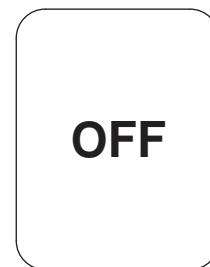

FG000089

Figure 112

2. Air Conditioner Button

This button activate or deactivate air conditioner.

When the air conditioner is turned on, the LED is lightened.

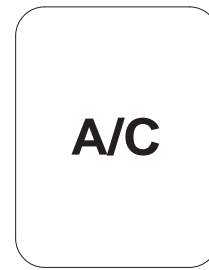

Figure 113

FG000105

3. Air Outlet Selector Button

This button is used to select which combination of air outlets be used.



Figure 114

FG000096

- A. Used to direct air flow to upper portion of operator's cabin from both the front and rear. It will also deliver air to the lower portion of operator's cabin from under the operator's seat.

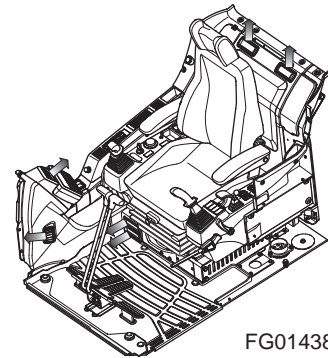

FG014385

Figure 115

- B. Used to direct air flow to lower portion of operator's cabin and feet.

This mode is mainly used for heating.

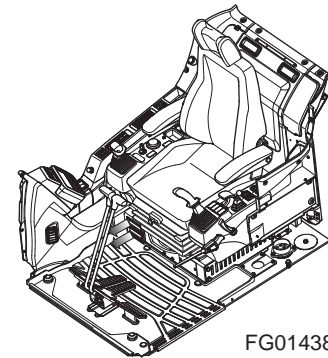

FG014386

Figure 116

- C. Used to direct air flow to the front window and to operator's feet.

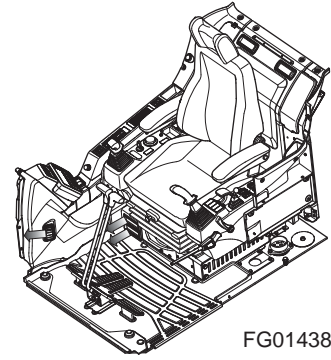

FG014387

Figure 117

4. Air Inlet Selector Button

This button is used to select fresh air from outside the cabin, or recirculate air within the cabin.

Pressing this switch enables the choice between fresh air and recirculating air within the operator's cabin. The select mode is displayed on the LCD.



FG000290

Figure 118

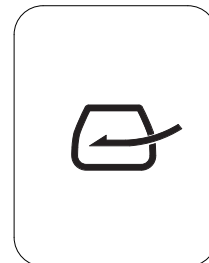

FG000291

Figure 119

5. Fan Speed Selector Buttons

These buttons are used to control the speed of the blower fan by the stages of low, middle and high.

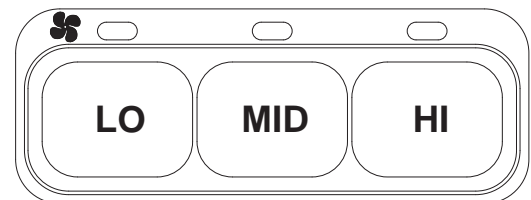

FG014377

Figure 120

6. Temperature Control Button

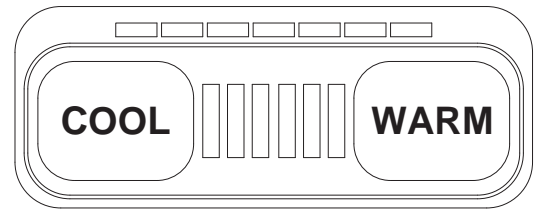

FG014378

Figure 121

Memory Function

The air conditioner panel has a memory function. When the starter switch is turned "OFF", the settings for the panel will be stored. When the excavator is started, the last stored setting will be used.

Additional Operating Instructions

A proper indoor temperature in summer is 5 - 6°C (10 - 12°F) less than the outdoor temperature.

Operate the air conditioner for twenty - thirty minutes a week to circulate the refrigerant in the system.

NOTE: *The blower button must be on "Three Bars".*

If operating the air conditioner or heater for a long time, operate the air inlet selector button, and when smoking, vent the air to the outside to prevent irritation to eyes.

STEREO

Before operating the stereo or CD player, read operation manual enclosed with stereo.

Stereo

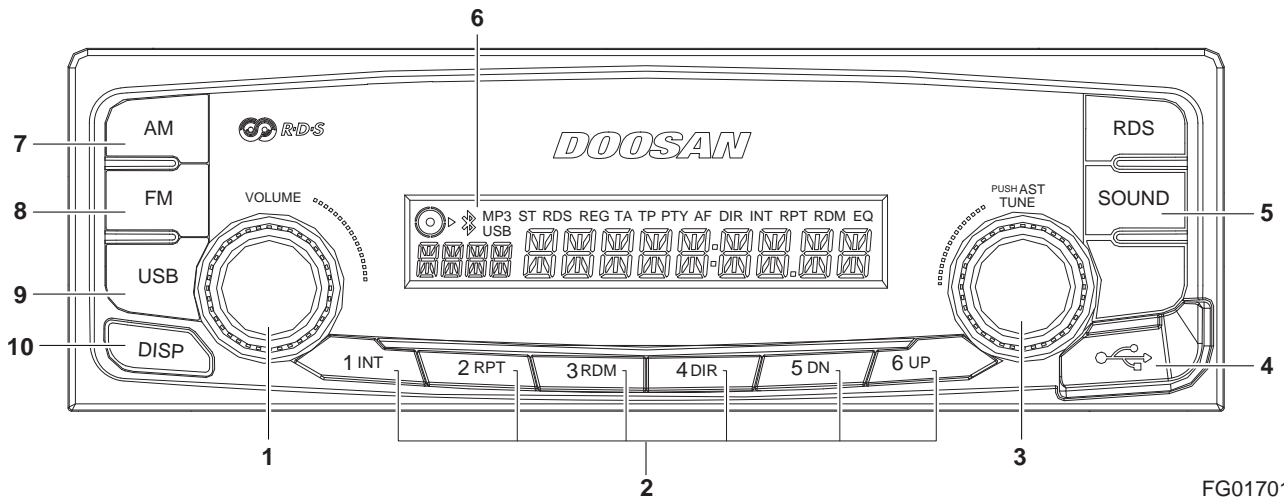

FG017016

Figure 122

| Reference Number | Description |
|------------------|----------------------|
| 1 | Power/Volume Control |
| 2 | Preset Station |
| 3 | Tuning Up/Down |
| 4 | USB Loading Port |
| 5 | Sound Mode Selector |

| Reference Number | Description |
|------------------|----------------------|
| 6 | LCD |
| 7 | AM Selection |
| 8 | FM Selection |
| 9 | USB Selection |
| 10 | Display Mode Control |

CD Player (Optional)

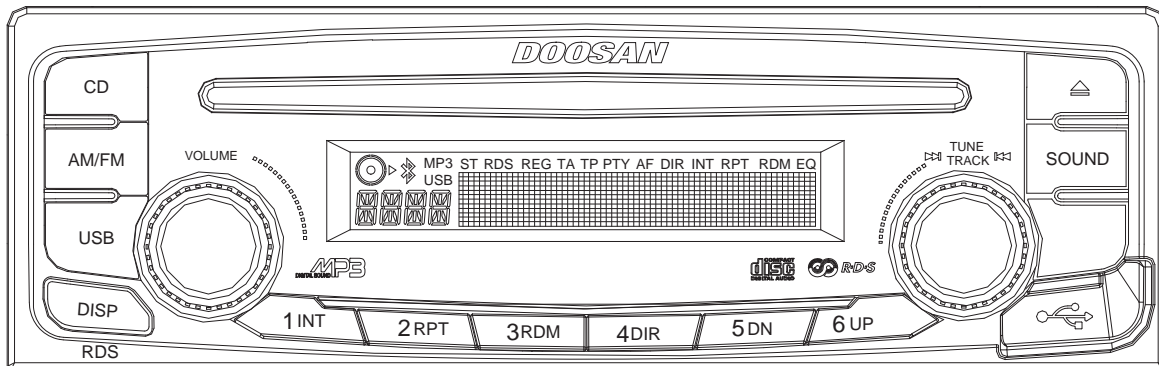

FG017017

Figure 123

MISCELLANEOUS ELECTRICAL DEVICES

Cabin Light

A light is installed on the top of the operator's cabin.

The light will work despite starter switch position.

NOTE: *If light is left "ON" for a long time while the engine is not running, the battery will be discharged.*

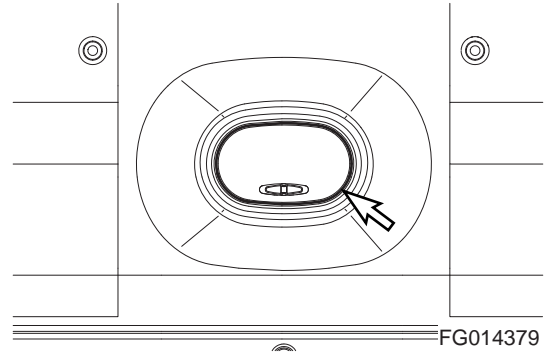

Figure 124

Pilot Cutoff Switch

When the safety lever is put into "LOCK" position, the switch deactivates the work and travel levers. With the work and travel levers deactivated, no digging/operational work can be done.

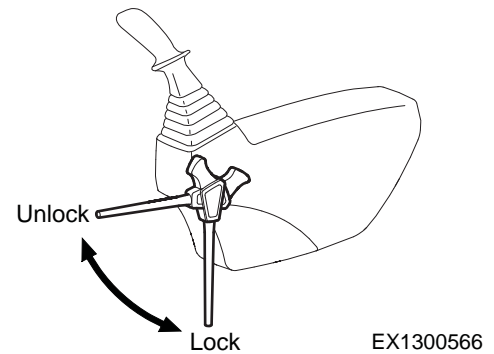

Figure 125

Circuit Breaker

A main circuit breaker is in the battery box. It will automatically cut off in case of an electrical short circuit or overload. This will prevent the electrical wiring and components from being burned or damaged.

If the circuit breaker is cut off, check all related circuits, this means something is wrong in the electric circuit.

After maintenance, press the red button for normal operation of circuit breaker.

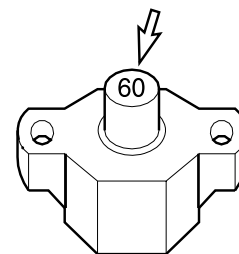

Figure 126

Fusible Link

A fusible link is in the battery box.

If the engine does not crank, first check that the starter switch is turned "ON" and that no power is available (No indicator lights will light.). Check that "A" portion (Figure 127) of the fusible link is not broken or burned through. Replace the fusible link if damage and investigate cause.



WARNING

AVOID DEATH OR SERIOUS INJURY

When changing the fusible link, replace the fusible link with the same capacity part. Otherwise, a fire could break out in the wiring harness and/or other components of the circuit. Always use original DOOSAN parts.

Fuse Boxes

There are two fuse boxes (Figure 128) in the right cover behind the seat. The fuses prevent electrical devices from overloading or shorting.

A decal attached inside the fuse box access cover indicates the function and amperage of each fuse.

NOTE: For a further explanation see "Fuse Boxes" on page 2-55.

Spare fuses are mounted on the inside of fuse box access cover.

Change a fuse if the element separates. If the element of a new fuse separates, check the circuit and repair the circuit.



CAUTION

AVOID INJURY

Always replace fuses with the same type and capacity fuse that was removed. Otherwise, electrical damage could result.

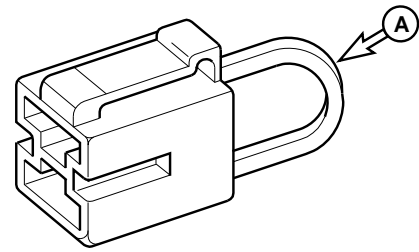

Figure 127

HAAE2120

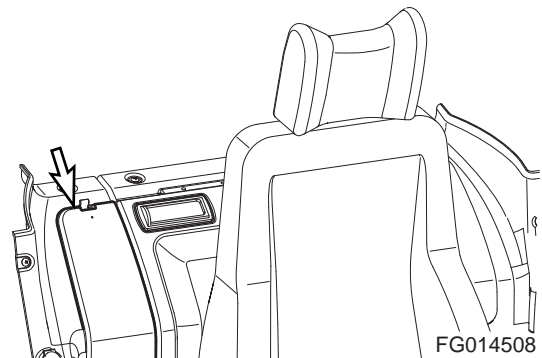

Figure 128

FG014508

SEAT ADJUSTMENT



WARNING

AVOID DEATH OR SERIOUS INJURY

Adjust the seat position before starting operations or after changing the operator.

Always fasten your seat belt while operating machine.

Adjust the seat so that the control levers and pedals can be operated freely and easily with the operator back against the backrest.

1. Forward/Backward Adjustment

Holding lever (1, Figure 129), raise it up, move the seat to the desired position. Release lever to lock the seat in the selected position. Adjustment range is 200 mm (7.9 in).

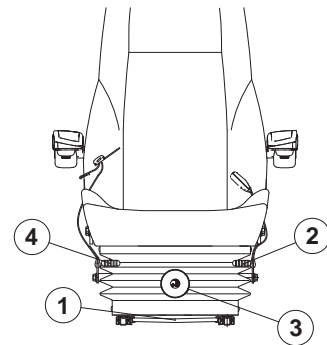

Figure 129

2. Seat Tilt and Height Adjustment

Forward Tilt

Push lever (2, Figure 129) down to adjust the angle of the front of the seat. There are four positions that it can be set at.

Rear Tilt

Pull lever (2, Figure 129) up to adjust the angle of the rear of the seat. There are four positions that it can be set at.

Seat Height

It is possible to move the seat up or down by combining adjustments forward and rear tilt. Adjust the seat according to operator's size and work conditions. Height adjustment is 60 mm (2.4 in).

3. Suspension Adjustment

Turning knob (3, Figure 129) to right makes the suspension harder. Turning knob to left makes the suspension softer. Adjust according to operator's weight by checking the weight indicator dial. Adjustment range is from 50 - 120 kg (110 - 265 lb).

4. Reclining Position Adjustment

Pulling up the right lever (4, Figure 129) allows the seat backrest to be moved forward or backward.

Sit with your back against the seat back when adjusting it. If your back is not touching the seat back, the seat back may suddenly move forward.

5. Armrest Angle Adjustment

The angle of each armrest can be adjusted by turning a dial (5, Figure 130) on bottom of armrest. When adjusting the angle, manually raise the armrest before turning the dial.

6. Lumbar Support Adjustment

A lumbar support is located in the seat back.

Turn the dial (6, Figure 130) counterclockwise to increase the force of the lumbar support

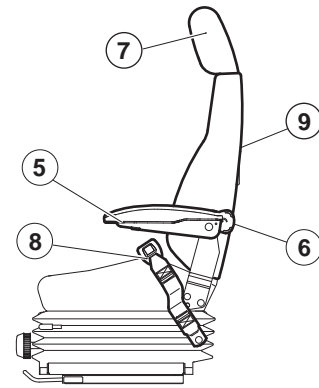

Figure 130

FG000778

7. Headrest

The headrest (7, Figure 130) can be adjusted forward/backward and up/down. Move it by holding both sides.

8. Seat Belt



WARNING

AVOID DEATH OR SERIOUS INJURY

The seat belt is for the operator's safety and should always be worn. Before driving the machine, adjust the seat to the desired position for maximum comfort and machine control, then fasten the seat belt. Seat belts must be worn across the pelvic region and adjusted snugly to lessen the chance and severity of injury in case of an accident. Never fasten a seat belt across the abdomen.

Under no circumstances should the operator be standing in the cabin when operating the excavator.

Do not adjust the seat position while the vehicle is moving because a loss of control can result. Stop the machine, apply the parking brake, and then adjust the seat.

Always, check the condition of seat belt and belt bracket before fastening it. Do not use it with twists in it. Replace belt or bracket if damaged or worn.

Seat Belt Locking and Unlocking

Insert belt end (1, Figure 131) into the buckle (2). Pull the belt to check that belt end is locked into buckle.

Adjust belt length so that it comfortably tight against the operator's pelvic region (hipbone).

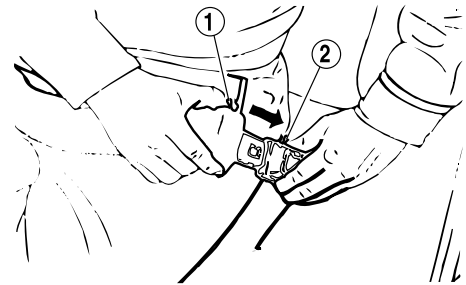

HAOB140L

Figure 131

Press the button (3, Figure 132) in the center of buckle (2) and pull out belt (1) to unlock.

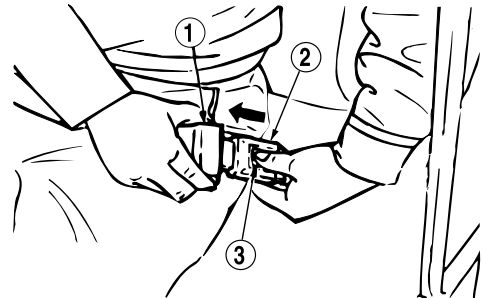

HAOB150L

Figure 132

9. Seat Back-pocket

The seat has a seat back pocket. It is used for storing the operation and maintenance manual.

10. Left and Right Control Stand Adjustment

For operator's convenience, the right and left control stands and seat can slide together, within a 140 mm (6.3 in) forward or backward travel distance.

Holding lever (10, Figure 133), raise it up, set the seat to desired position. Release lever to lock the seat in the selected position.

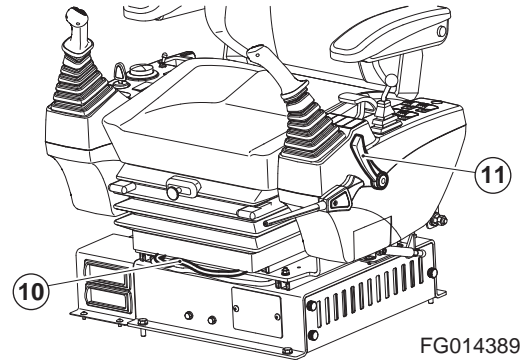

Figure 133

FG014389

11. Air Suspension Seat (Optional)

The operator seat is also available with air suspension for even better comfort. The switch (12, Figure 134) in the middle of the seat can be used to adjust the air cushion. If the switch is pressed, the seat become harder, and pulling it out makes the seat softer, when the air is bleed out.

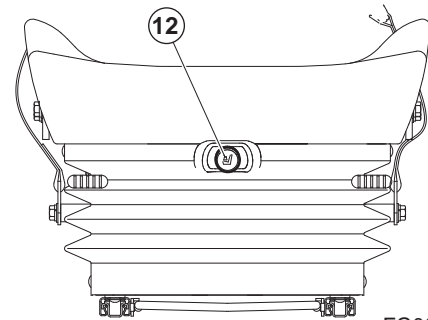

Figure 134

FG000187

12. Heating the Operator's Seat (Optional)

The air suspension seat can be heated. The switch on the left control stand is used to warm the seat. When heating is not needed or seat is warmed, turn the switch to "OFF" position.

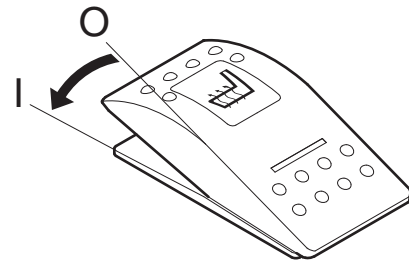

Figure 135

FG000034

CEILING COVER

NOTE: *If the machine is equipped with the transparent ceiling cover never use any chemical cleaners on its surface. Only use warm water to wash dust and dirt from its surfaces, and after that, dry it with a soft fabric towel.*

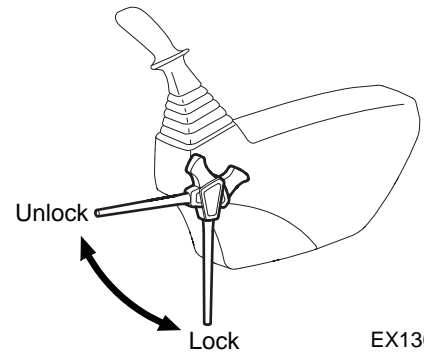

Figure 136

EX1300566

Opening the Ceiling Cover

1. Lower bucket or work tool to ground.
2. Move safety lever (Figure 136) to "LOCK" position.
3. Pull lock (1, Figure 137) in front center of ceiling cover and push it up with handle.

Closing the Ceiling Cover

1. Lower bucket or work tool to ground.
2. Move safety lever (Figure 136) to "LOCK" position.
3. Pull down cover with the handle (Figure 137) so lock (1) can be locked in the bracket in ceiling frame.

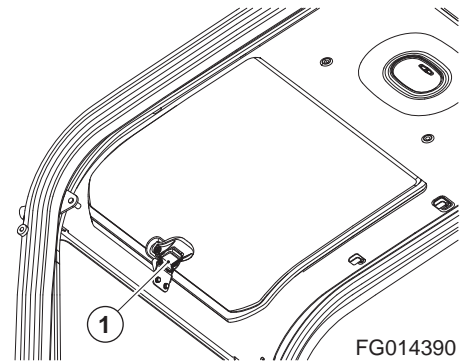

Figure 137

FG014390

FRONT WINDOWS



WARNING

AVOID DEATH OR SERIOUS INJURY

When leaving operator's seat, move safety lever to "LOCK" position (Figure 138), if not a serious accident could occur by accidentally moving work levers.

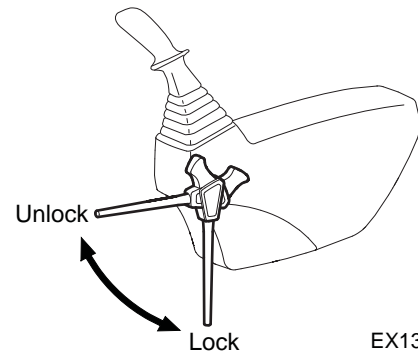

EX1300566

Figure 138

Front Upper Window

The front upper window can be housed in cabin's ceiling.

Opening the Window



WARNING

AVOID DEATH OR SERIOUS INJURY

When stowing front window in cabin roof, make sure both release levers (1, Figure 139) are latched.

1. Lower bucket or work tool to ground.
2. Move safety lever (Figure 138) to "LOCK" position.
3. Set engine speed control dial to "LOW IDLE". Allow engine to idle for three - five minutes.
4. Stop engine by turning key to "O" (OFF) position.
5. Hold window handles (1, Figure 139), then pull lock levers (2) to release lock. The top of front window will come out.
6. Pull window up, and push it against lock pin at rear of cabin. Make sure that it is securely latched.
7. Check that lock levers are securely latched in lock position.

NOTE: When front upper window is open, never extend your head or body through the window frame.

NOTE: If window happens to fall with a strong impact against machine, while some part of your body is extended out of cabin, it can result in bodily injury.

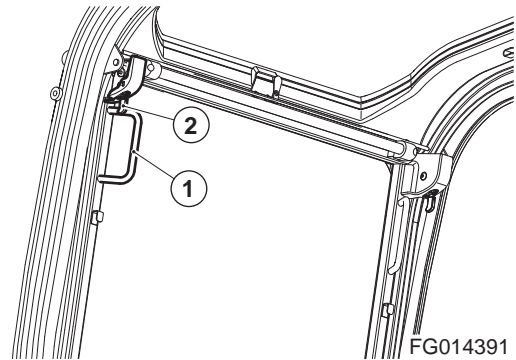

FG014391

Figure 139

Closing the Window



WARNING

AVOID DEATH OR SERIOUS INJURY

Be careful that your hands are not caught in window frame.

1. Lower bucket or work tool to ground.
2. Move safety lever (Figure 138) to "LOCK" position, and stop engine.
3. Holding upper handles (1, Figure 140) of front window with left and right-hand, pull lock levers (2, Figure 140) to release lock.
4. Push window forward, and lower it slowly.
5. When bottom of the window, reaches top of front bottom window, push front window to engage lock (2, Figure 139).
6. Check that lock levers are securely latched in lock position.

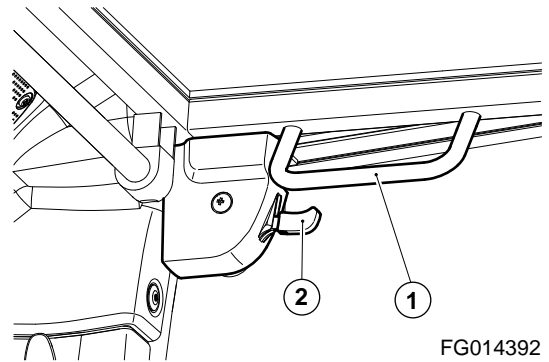

Figure 140

FG014392

Front Bottom Window

The front bottom window can be removed and stored in rear of cabin.

1. After stowing the front upper window in the cabin ceiling, remove bottom window (1, Figure 141) from cabin in direction of arrow.
2. Set bottom window in rubber holders (2, Figure 142) behind operator's seat. Secure window with left and right knobs (3) with push button (4).

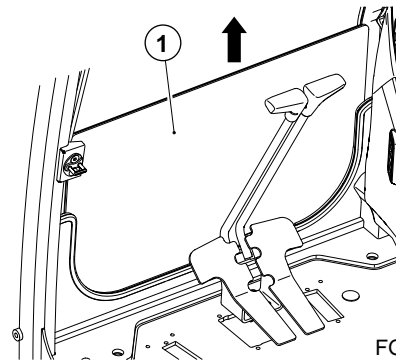

Figure 141

FG014393



WARNING

AVOID DEATH OR SERIOUS INJURY

Never have wet hands when handling a window. Never drop window or let it come into contact with other parts of the machine.

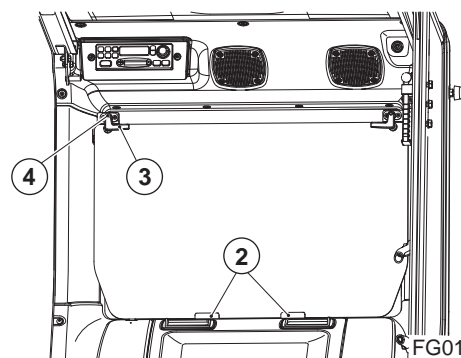

Figure 142

FG014394

DOOR SIDE LATCH

1. The door side latch (1, Figure 143) is used to secured door to side of cabin when it is opened.

NOTE: *Keep door closed and locked when machine is not in use.*

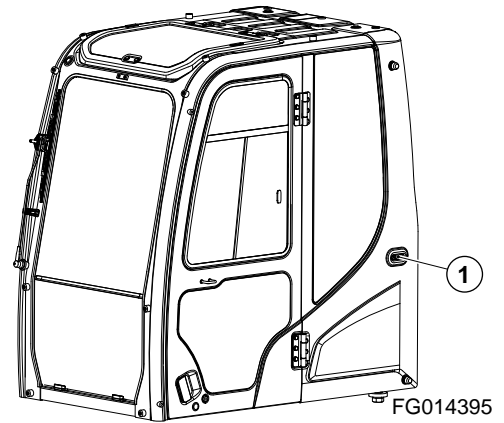

Figure 143

2. To release door from side of cabin, push latch lever (2, Figure 144) down. The latch lever is to the left of operator's seat.

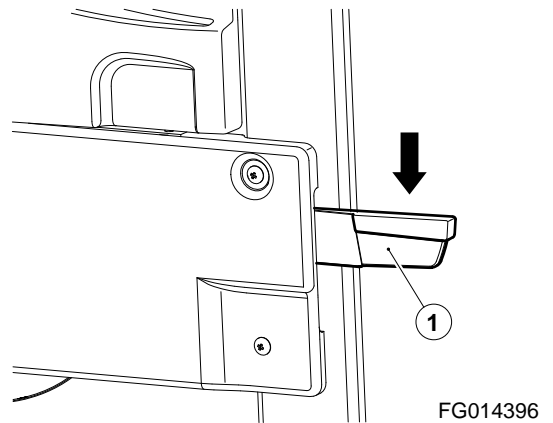

Figure 144

CABIN STORAGE COMPARTMENTS

There are two storage compartments behind the operator's seat. The large compartment (1, Figure 145) is for storing nonperishable items.

The covered other one (2, Figure 145) is interconnected with the air conditioner. So, it can be supplied with either warm or cool air when air conditioner is turned "ON".

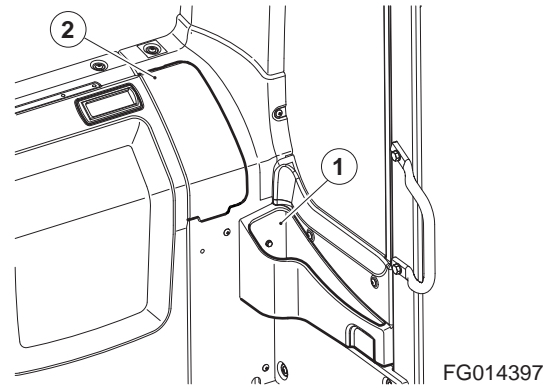

Figure 145

There is a separate small tray (3, Figure 146) on the right side of operator's seat.

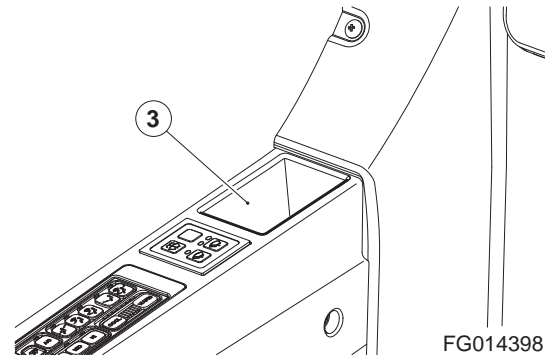

Figure 146

ASHTRAY

An ashtray (1, Figure 147) is on the right side of the operator's seat. Always close ashtray after putting out a cigarette.

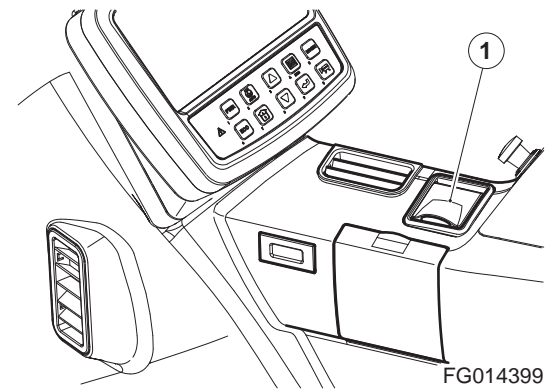

Figure 147

SUN VISOR

The sun visor can be used to reduce the amount of sunlight coming through the front window and ceiling cover.

When wanting to reduce the amount of sunlight coming through the front window, pull down bar (1, Figure 148) and hang on the hook (2, Figure 148).

In case of reducing the amount of sunlight coming through the ceiling cover, pull down the bar and hang on the hook (3, Figure 148).

When not wanting protection, unhook the bar from the hook. This will allow the sun visor to retract.

NOTE: Do not allow the visor to roll back up without holding it. Not holding it can result in damage to the visor and retract mechanism.

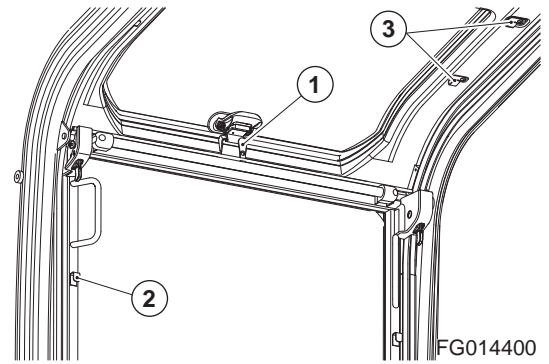

Figure 148

HANGER

A hanger (1, Figure 149) is located on upper left side of operator's seat.



WARNING

AVOID DEATH OR SERIOUS INJURY

Do not hang anything that will easily fall down, or will impair your view out of the cabin.

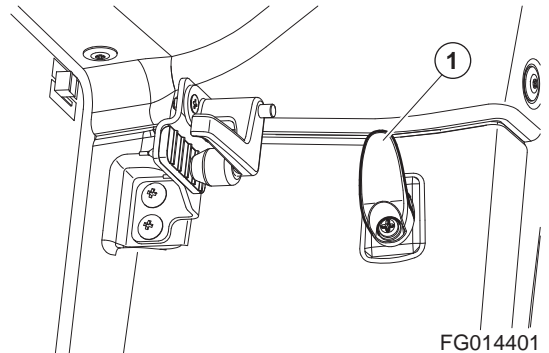

Figure 149

CUP HOLDER

There is a cup holder on the right side of the operator's seat (1, Figure 150). Open the access cover and lower it to a horizontal position.

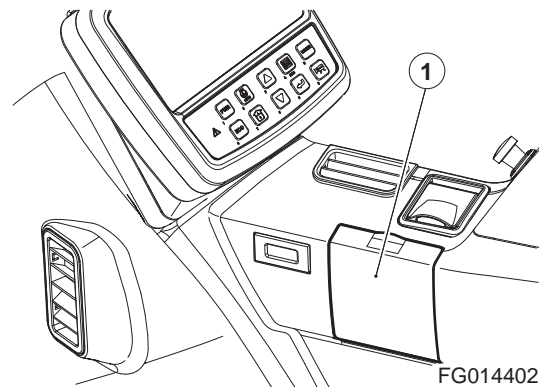

Figure 150

EMERGENCY GLASS BREAKING TOOL

The excavator is equipped with a glass breaking tool. It is located to the left pillar of the cabin. This tool can be used in case of an emergency situation which requires the breaking of glass to exit from the cabin. Grip handle firmly and use sharp point to break glass.



WARNING

AVOID DEATH OR SERIOUS INJURY

Protect your eyes when breaking the glass.

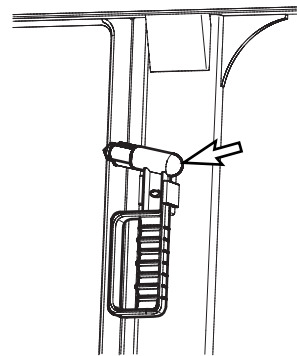

Figure 151

FG014380

MISCELLANEOUS ACCESS COVERS AND DOORS

Side Door

Open the side access door and slide prop rod (1, Figure 152) in slot (2) until it locks at end of slot.

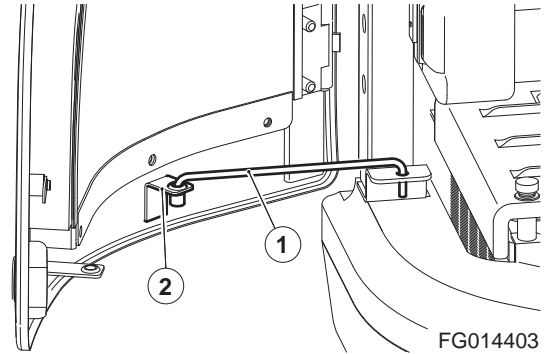

Figure 152

Control Valve Door

Opening

Open door and place the tip of rod at the bracket hole of the door (1, Figure 153) latches.

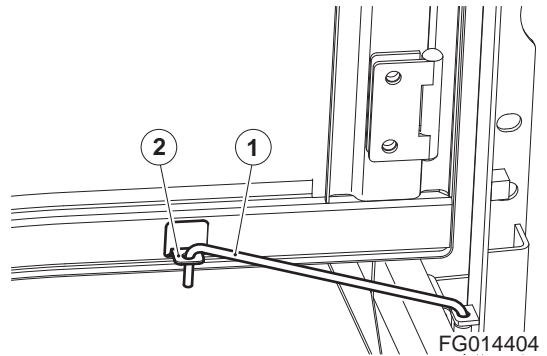

Figure 153

Engine Cover

Open the cover and slide prop rod (1, Figure 154) in slot (2) until it locks in notch at end of slot to support cover.

To close cover, move end of prop rod out of notch so it can slide in slot.

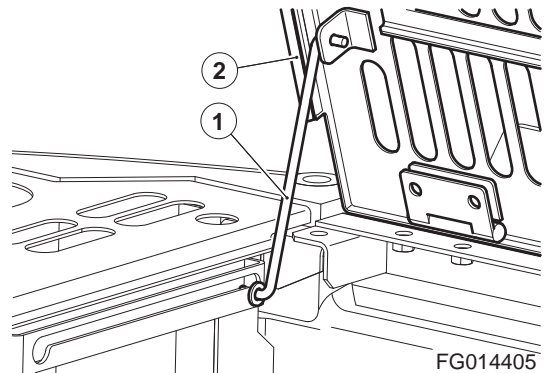

Figure 154

Operation

TO HANDLE A NEW EXCAVATOR

All DOOSAN excavators are inspected and adjusted before leaving the factory. However, it is required that operator follow these steps during the initial break-in period. Failure to follow these steps can result in damage to the equipment or reduced performance.

| Hour | Load |
|------------------------------------|---|
| For first 50 hours of operation. | Maintain about 80% load of full capacity (Engine rpm: 80% of rated rpm) |
| After first 50 hours of operation. | Full load |

If machine is used at full load before it is broken in, it may affect the life cycle and safe running operations. This could lead to problems later.

- NOTE:**
1. *Check daily for leakage of coolant, fuel, engine oil and hydraulic oil.*
 2. *Inspect all lubricants daily, add appropriate lubricants as required.*
 3. *During operation, monitor all instruments and gauges from time to time.*
 4. *Avoid an extreme engine load.*
 5. *Operate unit at 80% load until engine and all other components are at operating temperature.*
 6. *Check that work equipment is operating normally during operation.*
 7. *Check machine for loose parts or for damage that may have occurred during shipping.*
 8. *Check for loose wiring or terminals, check gauge operation and battery electrolyte level.*

Lubrication and Filters

1. Change engine oil and replace oil filter after first 50 hours of operation.
2. Change swing reduction device oil after first 250 hours of operation.
3. Change hydraulic oil return filter after first 250 hours of operation.
4. Replace travel and reduction gear oil after first 250 hours of operation.

NOTE: *For the replenishment of oil or grease, refer to "Inspection, Maintenance and Adjustment" on page 4-1 of this manual.*

STARTING AND STOPPING THE ENGINE

Inspection Before Starting Engine



WARNING

AVOID DEATH OR SERIOUS INJURY

If a flammable materials such as leaves, paper, etc. are allowed to accumulate on high temperature components, such as the engine muffler and turbo, a fire can occur. Fuel, lubricant and hydraulic oil leaks, can cause a fire. If there is anything wrong, perform the appropriate corrective action.

Before starting engine, inspect the following items:

1. Electric system - Check for damaged electric cables, and loose or missing connectors.
2. Fuel system - Drain water and sediment from fuel tank and water separator.
3. Hydraulic system - Check for hydraulic oil leaks, damaged tubing and hoses, and interference points of components.
4. Lubrication - Perform all daily and periodic maintenance services. Perform services according to reading shown on hour meter.
5. Safety - Perform a machine walk-around. Make sure that no one is under the machine or performing any maintenance on it, before starting engine.
6. After starting machine - Check that all operational controls and components, are in proper operating condition, and are functioning correctly. Stop operation and correct any malfunction before continuing work.

Operational Checks Before Starting Engine



WARNING

AVOID DEATH OR SERIOUS INJURY

When leaving operator's seat, set the safety lever to "LOCK" (Figure 1) position, if not a serious accident could occur by accidentally moving the travel or work levers.

1. Move safety lever to "LOCK" (Figure 1).
2. Fasten seat belt. Check for proper operation and condition.
3. Set all operation levers in "NEUTRAL".

NOTE: *Be careful not to touch any switches when starting engine.*

4. Rotate the starter switch to "I" (ON) position (Figure 2). Check all indicator lights. A warning buzzer will sound for about two seconds. After two seconds, all lights except the following will turn "OFF".
 - Charging warning light
 - Engine oil pressure warning light
 - Engine coolant temperature gauge
 - Fuel gauge
 - Hydraulic oil temperature gauge
 - Engine rpm (0 rpm) digital readout

NOTE: *If all the indicator lights do not come "ON" when the key is first turned, there is a problem.*

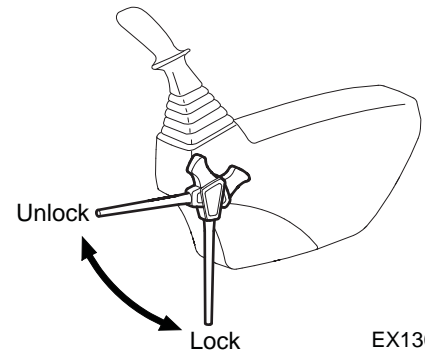

EX1300566

Figure 1

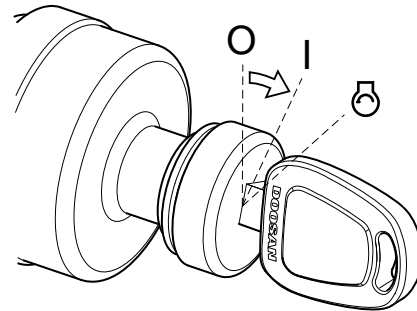

FG000084

Figure 2

Engine Start



WARNING

AVOID DEATH OR SERIOUS INJURY

Start the engine after sounding horn and making sure there are no people or obstacles in the area.

1. Perform all steps in "Operational Checks Before Starting Engine" on page 3-3.
2. Set engine speed control dial slightly above "LOW IDLE" (Figure 3).
3. Sound horn.

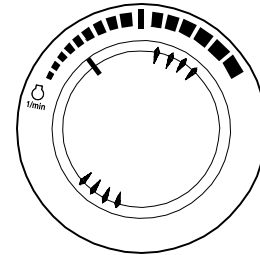

Figure 3

HAOB34L

4. Enter password.

NOTE: If the security system is "LOCKED", a four-digit password will be required to start the engine. If the system is "UNLOCKED", no password will be required and this display screen will not appear.

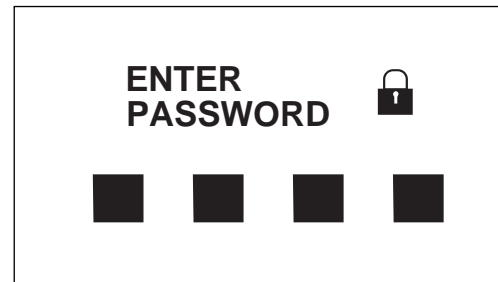

Figure 4

FG013717

5. Turn starter switch to "S" (START) position (Figure 5). Engine should start in approximately five seconds.



WARNING

AVOID DEATH OR SERIOUS INJURY

If the engine does not start after approximately fifteen seconds of cranking, release the starter switch. Wait about five minutes and repeat above step.

6. After engine has started, release key. Key will return to "I" (ON) position (Figure 5).
7. Follow procedures in "Hydraulic System Warm-up" on page 3-9.

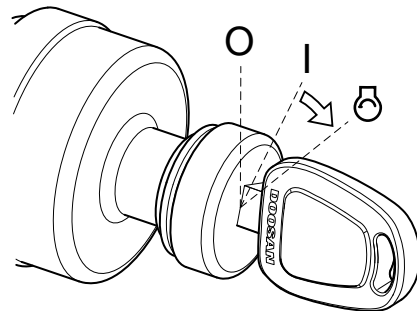

Figure 5

FG000085

8. After warming unit, check all operating indicators to make sure that all engine systems (oil pressure, coolant, etc.) are in the normal operating range. If any problems are noticed, stop engine. Normal indicators are:

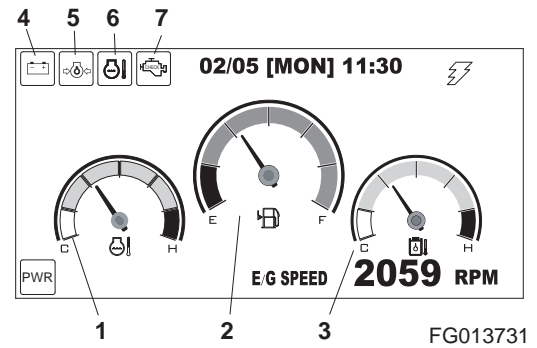

Figure 6

FG013731

| No. | Instrument Panel Light or Gauge | Indicator Reading |
|-----|--|-------------------|
| 1 | Engine Coolant Temperature Gauge | Blue Range |
| 2 | Fuel Gauge | Blue Range |
| 3 | Hydraulic Oil Temperature Gauge | Blue Range |
| 4 | Charging Warning Light | OFF |
| 5 | Engine Oil Pressure Warning Light | OFF |
| 6 | Engine Coolant Temperature Warning Light | OFF |
| 7 | Engine Check Warning Light | OFF |

9. Check color of exhaust smoke.
- No color or light blue - Engine is running in good condition.
 - Black - Incomplete combustion. Check cause.
 - White or dark blue - Engine is burning engine oil. Check cause.
10. Check for usual engine vibration and noises. If any are heard or felt, investigate cause.

NOTE: *If engine coolant temperature gauge pointer moves into the red zone, the engine coolant temperature warning light will turn "ON", a warning buzzer will sound, and the engine speed will be automatically reduced. Allow the engine to run at low idle speed until temperature gauge registers in the blue zone again. When the blue zone is reached, allow the engine to idle for an additional three - five minutes before shutting down the engine. If not allowed to idle, heat surge may develop which will damage the engine. Allowing the engine to idle will dissipate heat. Check the coolant level, look for a loose fan belt, inspect for debris around radiator, and so on.*

Cold Weather Starting

WARNING

AVOID DEATH OR SERIOUS INJURY

DO NOT USE STARTING FLUIDS. The preheat system could cause the starting fluid to explode. Starting fluids should never be used.

1. Perform all steps in "Operational Checks Before Starting Engine".
2. Set engine speed control dial slightly above "LOW IDLE" (Figure 7).
3. Sound horn.

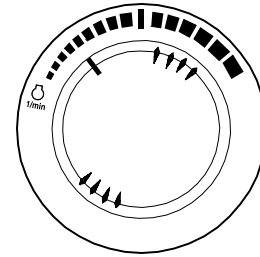

HAOB34L

4. Turn starter switch to "I" (ON) position (Figure 8). When preheat cycle is completed, the preheat indicator light (1, Figure 9) will turn "OFF".

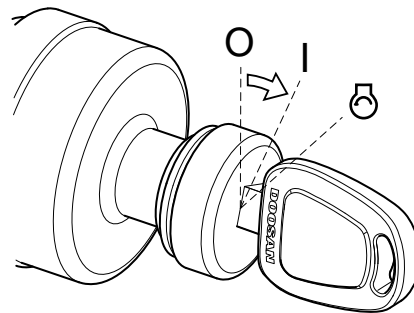

FG000084

Figure 8

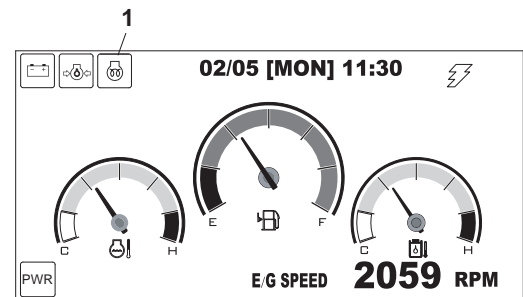

FG013732

Figure 9

5. After the preheat completion, immediately turn starter switch to "I" (START) position (Figure 10). Engine should start in approximately five seconds.



WARNING

AVOID DEATH OR SERIOUS INJURY

If the engine does not start after approximately fifteen seconds of cranking, release the starter switch. Wait about five minutes and repeat above step.

6. After engine has started, release key. Key will return to "I" (ON) position (Figure 10).
7. After the engine starts, check all operating indicators to make sure that all engine systems (oil pressure, coolant, etc.) are in the normal operating range. If any problems are noticed, stop engine.
8. Follow "Hydraulic System Warm-up" procedures in this section. (See page 3-9)

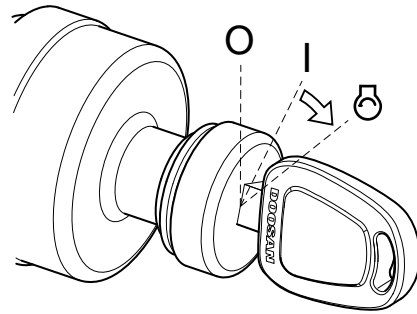

Figure 10

FG000085

Starting Engine With a Booster Cable



WARNING

AVOID DEATH OR SERIOUS INJURY

1. An explosive gas is produced while batteries are in use or being charged. Keep flames or sparks away from the battery area.
 2. Charge batteries in a well ventilated area.
 3. Always wear eye protection when starting a machine with jumper cables.
 4. Improper jump starting procedures can cause an explosion resulting in personal injury.
 5. Jump start vehicles on dry ground or concrete. Do not jump start the machine on a steel floor, because the floor is always grounded.
 6. When starting from another machine, make sure the machines do not touch.
 7. Always connect the auxiliary battery positive (+) terminal too depleted battery positive (+) terminal first. Then connect auxiliary battery negative (-) terminal to the frame of the depleted battery machine second.
 8. Connect positive cable first when installing cables and disconnect the negative cable first when removing.
-



Figure 11

HAO440L

IMPORTANT

The machine has a 24V (-) negative ground electrical system. Use the same capacity 24V booster batteries when jump starting engine.

If the batteries are drained during starting procedures, jump-start engine using auxiliary or booster batteries according to the following procedure:

Connecting the Booster Batteries

1. Stop engine of the machine on which booster batteries (3, Figure 12) are mounted.
2. Connect one end of red cable (1, Figure 12) to the positive (+) terminal of the machine batteries (4), and the other end to the positive (+) terminal of the booster batteries.
3. Connect one end of black cable (2, Figure 12) to the negative (-) terminal of the booster batteries (3), and then make ground connection to the upper frame (5) of the machine to be started with the other end of black (-) cable (2, Figure 12). When making the last connection to upper frame, be sure to connect the cable end as far away from the machine batteries as possible. **DO NOT CONNECT DIRECTLY TO THE NEGATIVE BATTERY TERMINAL.**
4. Start the engine.

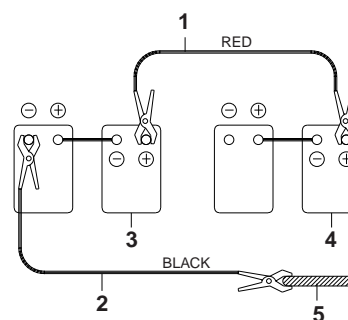

ARO0440L

Figure 12

Disconnecting the Booster Batteries

1. Disconnect black negative (-) cable (2, Figure 12) from the machine frame (5) first.
2. Disconnect the other end of black negative (-) cable (2, Figure 12) from the booster batteries (3).
3. Disconnect red positive (+) cable (1, Figure 12) from the booster batteries (3).
4. Disconnect red positive (+) cable (1, Figure 12) from the machine batteries (4).

Hydraulic System Warm-up



AVOID DEATH OR SERIOUS INJURY

If a problem or abnormal operation occurs, immediately stop engine. Allow excavator to reach normal operating temperature before starting work, especially in cold weather.

The correct operating temperature of the hydraulic oil is 50° - 80°C (120° - 175°F). Make sure to follow the procedures listed here for hydraulic fluid warm-up.

1. Run engine for approximately five minutes set at the middle of the speed range, without a load.

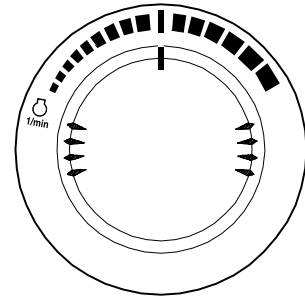

Figure 13

HAOB410L

2. Move safety lever to "UNLOCK" position.

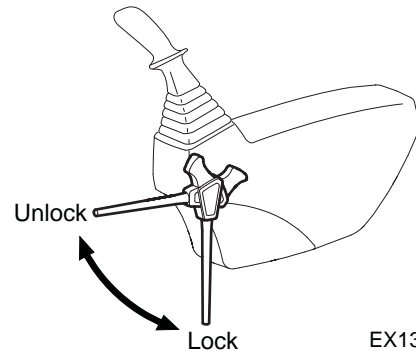

Figure 14

EX1300566

3. Slowly cycle boom, arm and bucket cylinders about five times without a load to circulate the oil through the system. Do this for five minutes.
4. Check for clearance and fully raise the front attachment. Swing clockwise 3 revolutions. Swing counterclockwise 3 revolutions.
5. Travel forward and reverse at low speed for two revolutions of the drive sprocket.

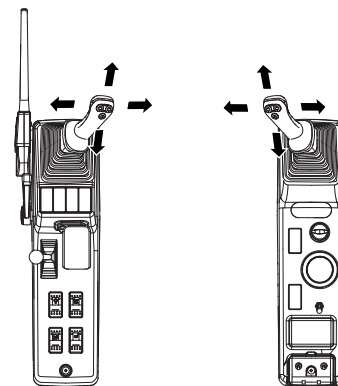

Figure 15

FG014408

Hydraulic System Warm-up – Cold Weather

1. Run engine at "LOW IDLE" (no load) for five minutes (Figure 16).

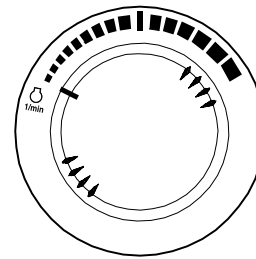

Figure 16

HAOB290L

2. Run engine for approximately five minutes set at the middle of the speed range, without a load (Figure 17).

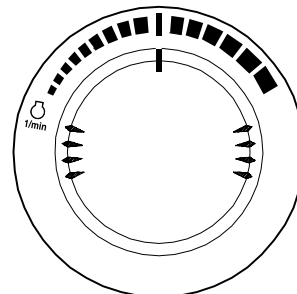

Figure 17

HAOB410L

3. Move safety lever to "UNLOCK" position.

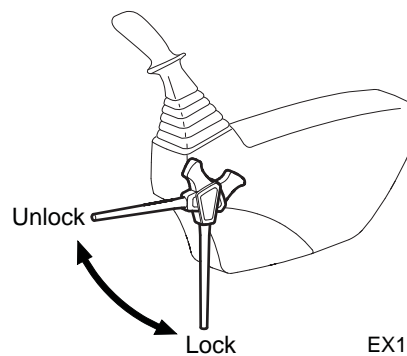

Figure 18

EX1300566

4. Slowly cycle boom, arm and bucket cylinders about five times without a load to circulate the oil through the system. Do this for five minutes.

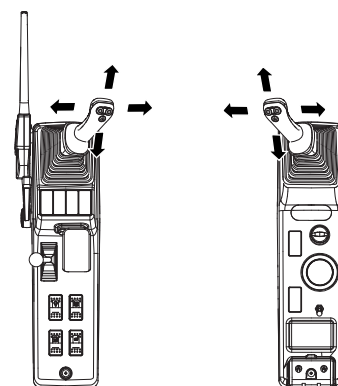
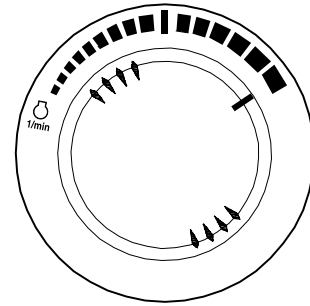

Figure 19

FG014408

5. Set engine speed control dial to "HIGH IDLE" (Figure 20).
6. Repeat Step 4 for five minutes. If working speeds continue to be slow, continue to operate, but use extreme caution because the machine function may be erratic.
7. Check for clearance and fully raise the front attachment. Slowly swing clockwise 3 revolutions. Slowly swing counterclockwise 3 revolutions.
8. Travel forward and reverse at low speed for two revolutions of the drive sprocket.



HAOB550L

Figure 20

Stopping Engine

NOTE: Allow engine to idle for three - five minutes before shutting down the engine. If not allowed to idle, heat surge may develop which will damage the engine. Allowing the engine to idle will dissipate heat.

1. Park excavator on level and firm ground.
2. Lower front end attachment to ground and make sure all operating controls are in "NEUTRAL".
3. Move safety lever to "LOCK" position (Figure 22).

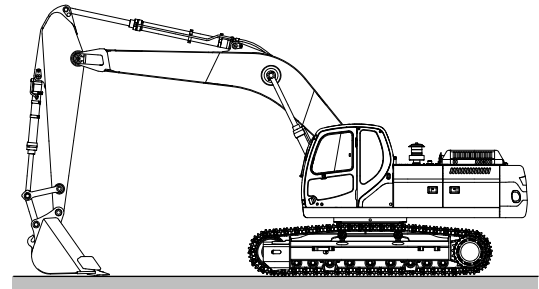

FG000111

Figure 21

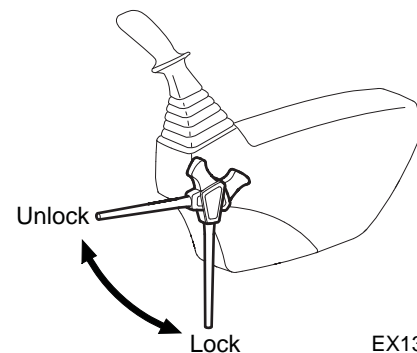

EX1300566

Figure 22

4. Set engine speed control dial to "LOW IDLE" (Figure 23). Allow engine to idle for three - five minutes.

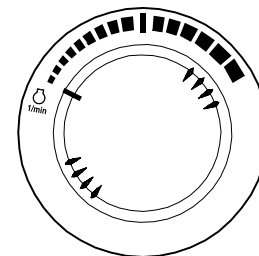

HAOB290L

Figure 23

5. Stop engine by turning key to "O" (OFF) position (Figure 24).
6. Remove key from starter switch.

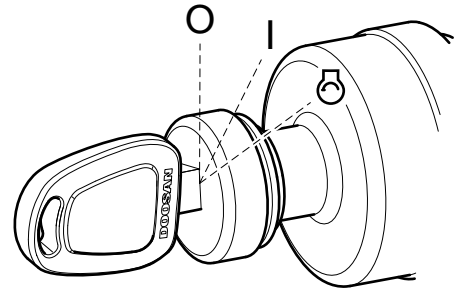

FG000175

Figure 24

Check and Confirmation After Stopping Engine

1. Repair excavator, if there are any coolant or oil leaks.
2. Inspect front attachment and under carriage for abnormal appearances. Correct any problems.
3. Fill fuel tank.
4. Get rid of any accumulated flammable materials such as leaves and paper etc. in engine compartment.
5. Clean all mud, etc. from undercarriage and tracks. Make sure that all steps and hand holds are clean, and that operator's cabin is clean.

SAFETY LEVER



AVOID DEATH OR SERIOUS INJURY

When stopping engine or leaving the operator's seat, "LOCK" the safety lever, otherwise, a serious accident can occur by accidental movement of travel and work levers.

Whenever leaving the operator's seat, make sure the engine is stopped and the safety lever is "LOCKED".

Especially, when adjusting the seat, control stands, or raising the front window, lower window, or ceiling cover, never forget to lock the safety lever in its "LOCKED" position.

Be careful not to move the work levers (joysticks) when moving safety lever.

1. Push safety lever (Figure 25) down into "LOCKED" position. When safety lever is in the "LOCKED" position, the front attachment, swing and travel movement will be disabled even though a lever is moved.

NOTE: Lower bucket (front attachment) to ground. Place all control levers in "NEUTRAL" and stop engine, before using the safety lever.

2. Move safety lever (Figure 25) to "RELEASE/UNLOCK" position, by pulling it up before starting work.

NOTE: When the engine is not running, but the safety lever is "RELEASED" and the starter key is tuned "ON", moving the work levers (joysticks) can result in movement. The charged accumulators in the system will provide pilot pressure for control valve spool movement.

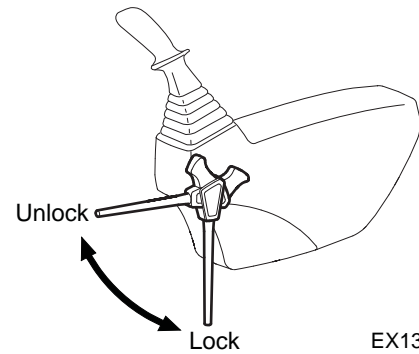

Figure 25

EX1300566

TRAVEL



WARNING

AVOID DEATH OR SERIOUS INJURY

1. Before operating the travel levers, make sure that you know in which direction the machine is pointing. Look at the end of the track assemblies. If the drive motors are visible while sitting in the operator's seat, you are looking at the back end of the track assembly (therefore, you are looking backwards). In this case, the response of the travel levers will be the reverse of normal operation.
2. Before moving, make sure that there are no personnel in the way or on the machine. Sound the horn to alert workers that you are about to move the machine.
3. Be sure the path is clear during travel.
4. Use extreme caution when reversing travel. Be sure there is a clear path behind the machine.
5. Make sure to operate the travel control levers smoothly to avoid sudden starts or stops.
6. Before leaving the operator's seat, make sure to lock out all control systems and stopped engine to avoid accidental activation.

Automatic Travel Speed Control



WARNING

AVOID DEATH OR SERIOUS INJURY

Do not change the travel mode while traveling. Always use speed mode "O" when traveling down a slope. It is very dangerous to change to speed modes indicated "I" or "II" while going down a slope. Only change travel mode after coming to a complete stop.

Two travel speed ranges can be selected by using the travel speed selector switch on the control panel (Figure 26).

"O" (LOW) - In this position low travel speed and a higher torque are selected.

"I" (HIGH) - In this position high travel speed and a lower torque are selected.

"II" (AUTOMATIC) - Setting the control at the "II" position enables the machine to change to a different speed range automatically. This change happens automatically depending on the hydraulic oil pressure in the travel circuit. When hydraulic oil pressure rises, the travel speed is automatically set to low.

An example is if the machine is traveling on a flat, solid surface, the higher speed range would be used. When a slope is encountered, the speed drops and the travel circuit hydraulic pressure rises, causing the control circuit to shift to the higher torque, lower speed range.

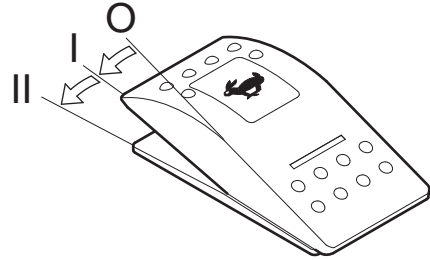

FG000023

Figure 26

Travel Control Lever Operation

1. To travel straight (Figure 27), push both travel control levers/pedals fully forward or backwards. The farther the levers/pedals are pressed, the faster the travel speed.

NOTE: "X" is the sprocket end of the track.

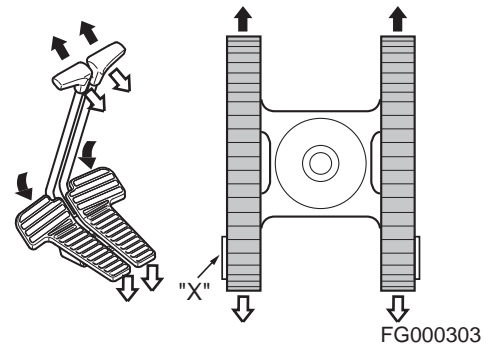

Figure 27

2. Pivot turns (Figure 28) are made by rotating only one track forward or backward. The machine will pivot on the nonmoving track.

NOTE: "X" is the sprocket end of the track.

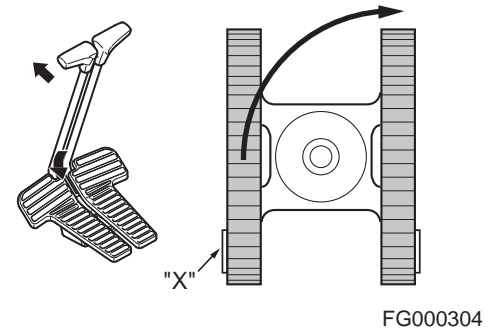

Figure 28

3. Spin turns (Figure 29) are made by rotating one track forward and one track backward. The machine will spin around its center point, thus counterrotating.

NOTE: "X" is the sprocket end of the track.

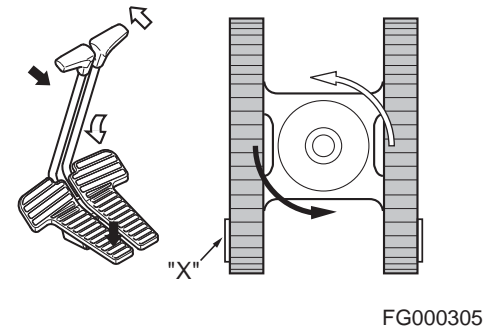

Figure 29

4. Stopping travel (Figure 30) - Returning travel levers to "NEUTRAL" position will automatically apply brakes and stop excavator.

NOTE: "X" is the sprocket end of the track.

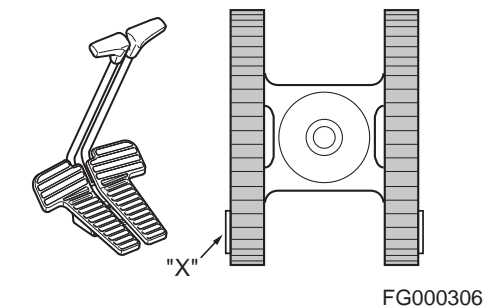

Figure 30

General Travel Instructions

1. Set engine speed control dial (Figure 31) on desired speed.

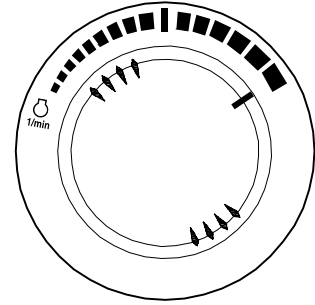

Figure 31

HAOB550L

2. Move safety lever to "UNLOCK" position, and folding the front, raise it 40 - 50 cm (16 - 20 in) above ground. See Figure 32.

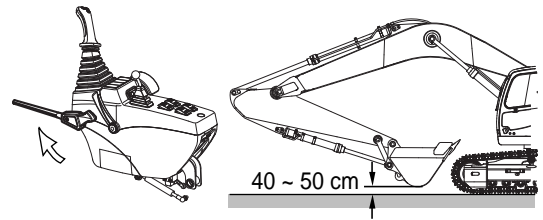

Figure 32

FG014412

3. When possible, travel on firm and level ground. Avoid sudden movements and sharp turns.
4. When traveling on rough ground, travel at a slow speed [1.0 - 1.5 km/h (0.62 - 0.93 MPH)]. Reduced engine speed, to avoid shock loading the equipment. Be careful that an excessive force is not added to equipment by touching or climbing on rocks.



Figure 33

FG000423

5. On rough, frozen or uneven terrain, travel slowly.



WARNING

AVOID DEATH OR SERIOUS INJURY

When traveling, keep bucket from 20 - 30 cm (8 - 12 in) above ground.

Do not travel backward on a slope.

Never turn or travel crosswise on a slope.

Choose a safe alternate route before climbing a slope.

If excavator starts to slip or becomes unstable, lower the bucket immediately into the ground, using it as a brake.

Avoid working on slopes, because there is a danger of overturning by becoming unbalance while swinging and performing front attachment operations.

It is very dangerous to swing towards bottom of slope with a loaded bucket.

In unavoidable cases level the slope with fill soil, to make the vehicle as horizontal as possible. See Figure 34.

Do not travel on slopes more than 30° because of turnover danger.

6. Travel straight up or down slopes, never diagonally across the slope. See Figure 35 and Figure 36. Extend the arm and lower the boom to keep the bucket about 20 - 30 cm (8 - 12 in) off the ground. If the machine starts to slide or becomes unstable, lower the bucket to regain control. If the engine stalls, lower the bucket, make sure that all controls are in the neutral position and restart the engine.

NOTE: Even though engine stops on a slope, do not operate swing control. The hydraulic accumulators can cause the unit to swing.

NOTE: Do not open or close operator's door on a slope. Make sure door is latched.

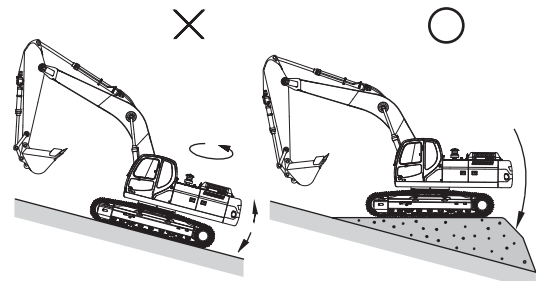

FG000212

Figure 34

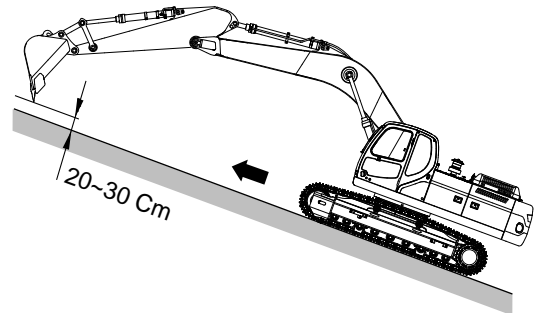

FG000126

Figure 35

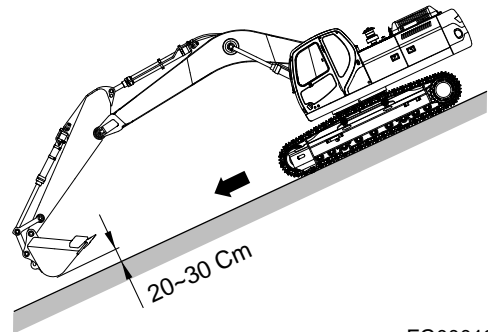

FG000128

Figure 36

7. If dirt or mud builds up in the track frame, raise each track and rotate and clean that track.



CAUTION

AVOID INJURY

When using the boom and arm to lift any portion of the machine, roll the bucket until round base is against the ground. The angle of the arm to the boom must be at 90°.

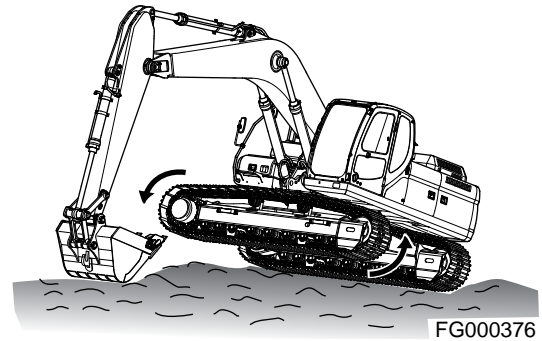

FG000376

Figure 37

Make sure that material buildup has been cleared. See Figure 37 and Figure 38.

8. The excavator can travel in water that comes up to center of upper carriage rollers. Make sure that footing is solid so the machine will not sink. See "Working in Water" on page 3-30.

NOTE: *If the machine is submerged to the point that water or mud gets into the swing bearing or center joint, stop machine operation. Remove machine from the submerged location to firm, dry ground. Do not operate until proper inspection and maintenance have been completed. Refer to the Shop Manual or contact your distributor.*

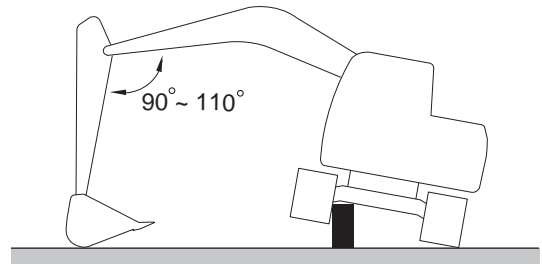

EX1300536

Figure 38

OPERATING INSTRUCTIONS

Engine Speed Control

Engine speed can be manually adjusted using the engine speed control dial, Increase engine speed by rotating the control knob clockwise. Decrease engine speed by rotating the control knob counterclockwise.

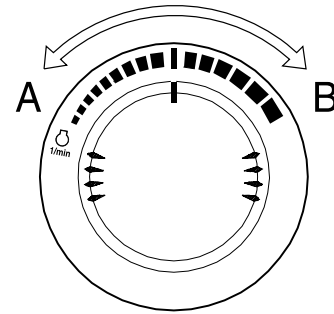

Figure 39

HAOA690L

IMPORTANT

The engine speed control system has been set at the factory and should not require adjustment as part of routine maintenance.

Mode Selection

More efficient work can be done by choosing a proper power and work mode combination, suitable to type of work and conditions. Use the mode selection according to following guide.

Power Mode

1. When the starter switch is turned "ON" the power mode is automatically defaulted to the standard setting.
2. Select a proper power mode using button (1, Figure 40) before starting work.
3. When the power mode button (1, Figure 40) is pressed, a signal sounds, changing the power mode to either "ON" or "OFF". When the power mode is turned "ON", the symbol indicates on the screen.

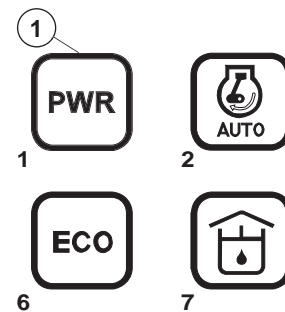

Figure 40

FG013733

Deactivate the power mode by pressing it a second time. When the power mode is turned "OFF", the symbol of standard mode indicates on the screen and the power mode returns to the standard mode.

| Mode | Selection Point |
|---------------|--|
| Power Mode | <ul style="list-style-type: none"> • Required to perform heavy work in a short period of time. • Fast speed loading. • Fast speed travel. |
| Standard Mode | <ul style="list-style-type: none"> • General work. • Optimize fuel consumption. |
| Economy Mode | <ul style="list-style-type: none"> • Light work. • Minimize fuel consumption. • Reduce noise. |

Economy Mode

1. When the starter switch is turned "ON" the power mode is automatically defaulted to the standard setting.
2. Select a proper power mode using button (2, Figure 41) before starting work.
3. When the economy mode button (2, Figure 41) is pressed, a signal sounds, changing the economy mode to either "ON" or "OFF". When the economy mode is turned "ON", the symbol appears on the screen.
Deactivate the economy mode by pressing it a second time. When the economy mode is turned "OFF", the symbol of standard mode. Appears on the screen and the economy mode returns to the standard mode.

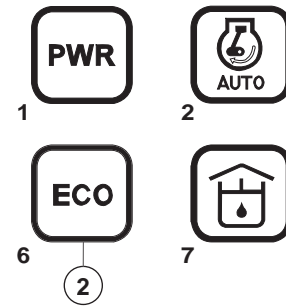

Figure 41

FG013742

Auto Idle Mode

1. The system will automatically reduce engine speed to idle speed approximately four seconds after all of the control levers are in the neutral position. When a pilot function is activated, engine speed is automatically returned to the preselected range.
2. When the starter switch is turned "ON", the work mode is automatically defaulted to "AUTO IDLE".
3. When the symbol is turned "ON", the auto idle function is activated. Deactivate the auto idle function by again pressing the auto idle selector button (3, Figure 42). Now the symbol will be turned "OFF".

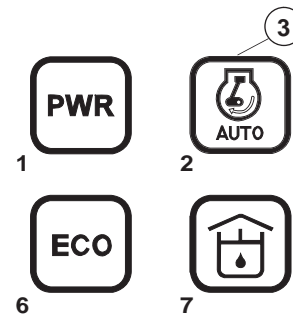

Figure 42

FG013743



WARNING

AVOID DEATH OR SERIOUS INJURY

Turn "OFF" auto idle function when performing work in close operating area, i.e., work in a narrow area and loading/unloading on or off a trailer.

Boost Mode

1. Power boost switch is used to gain maximum digging force.
2. The power boost is activated while the lower button is being pressed on top of the right-hand work lever (joystick). The breaker/boost/shear selector switch must be in the "O" (BOOST) position.

NOTE: *The power boost mode does not affect forward and reverse travel.*

Do not use this switch for more than ten seconds.

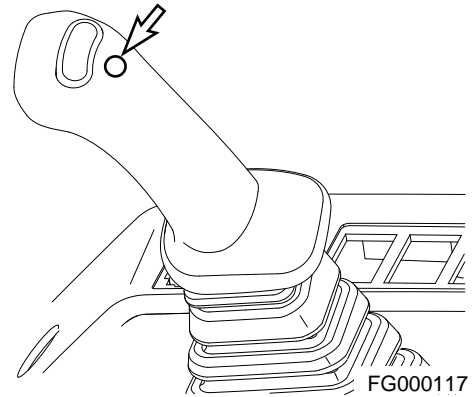
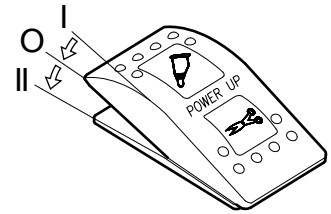

Figure 43 Right-hand Work Lever (Joystick)

Work Levers (Joysticks) (ISO Pattern)



WARNING

AVOID DEATH OR SERIOUS INJURY

Check surrounding area before swinging. When operating a lever while in auto idle, do it carefully, because the engine speed will increase rapidly.

NOTE: When starting work, move work levers (joysticks) slowly and check movement of swing and front attachment.

This equipment is manufactured using the lever configuration described in ISO standards. Do not change valving, hoses, etc., that would change this standard. The boom, arm and bucket movements and swing direction of work levers (joysticks) are as follows:

Left-hand Work Lever (Joystick) (Figure 44 and Figure 45)

1. Arm dump
2. Arm crowd
3. Left swing
4. Right swing

NOTE: The swing brake is spring applied and hydraulically released. It is always engaged when the work lever (joystick) is in "NEUTRAL" or the engine is stopped.

NOTE: The following is not a mechanical malfunction but a proper phenomenon of the excavator. When operating the arm, it may stop momentarily. When the arm is operated, the weight of the arm can cause it to move faster than the amount of oil being supplied.

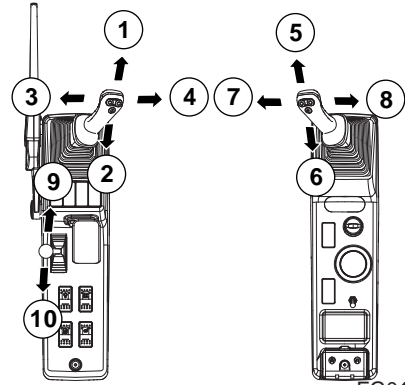

FG014413

Figure 44

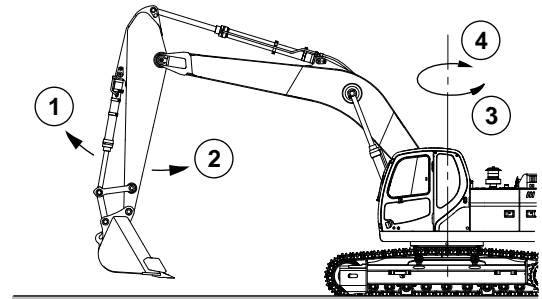

FG000119

Figure 45

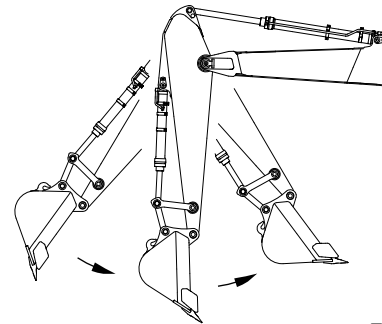

FG000120

Figure 46

Right-hand Work Lever (Joystick) (Figure 44 and Figure 47)

5. Boom down
6. Boom up
7. Bucket crowd
8. Bucket dump

NOTE: Even after stopping the engine, the front can be lowered to the ground by operating work lever (joystick), by setting safety lever on "UNLOCK" position and turning starter switch "ON".

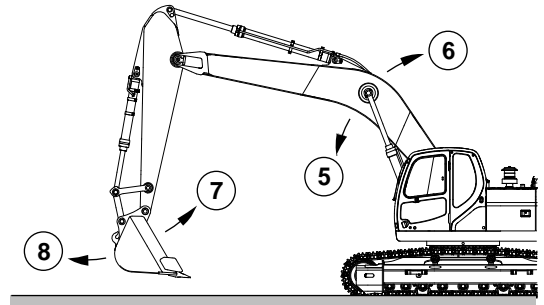

FG000121

Figure 47

Change Machine Control Pattern by Select Valve (If Equipped)



WARNING

AVOID DEATH OR SERIOUS INJURY

Check surrounding area before swinging. When operating a lever while in auto idle, do it carefully, because the engine speed will increase rapidly.

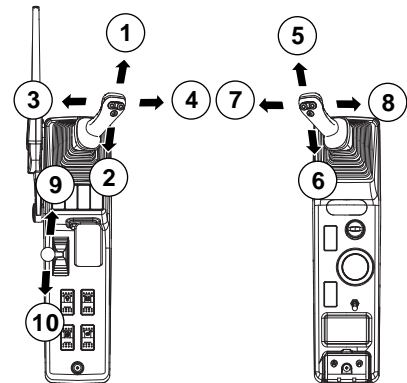

FG014413

Figure 48

NOTE: When starting work, move work levers (joysticks) slowly and check movement of swing and front attachment.

The machine control pattern can easily be changed to the ISO standard or to the standard backhoe loader hydraulic system (BHL) by changing the position of the select valve (if equipped). Use the following procedure to change the position of the select valve.

The select valve is located in the rear of the cabin.

1. Rotating spool to the ISO position or to the BHL position. (Figure 49)

<ISO PATTERN>

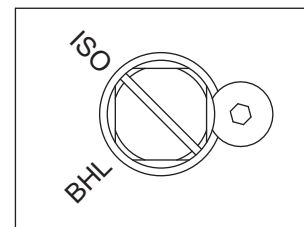

<BHL PATTERN>

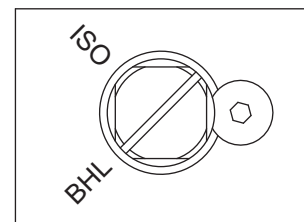

FG004954

Figure 49

Work Levers (Joysticks) (BHL Pattern)

Left-hand Work Lever (Joystick) (Figure 48 and Figure 50)

1. Boom down
2. Boom up
3. Left swing
4. Right swing

NOTE: The swing brake is spring applied and hydraulically released. It is always engaged when the work lever (joystick) is in "NEUTRAL" or the engine is stopped.

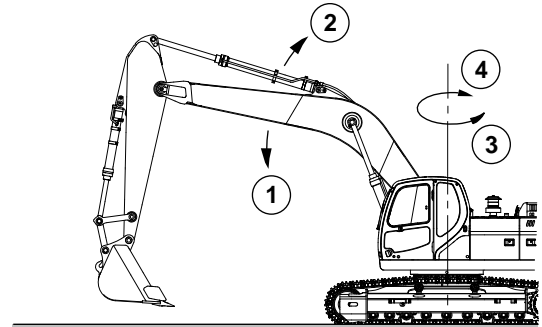

FG004951

Figure 50

Right-hand Work Lever (Joystick) (Figure 48 and Figure 51)

5. Arm dump
6. Arm crowd
7. Bucket crowd
8. Bucket dump

NOTE: The following is not a mechanical malfunction but a proper phenomenon of the excavator. When operating the arm, it may stop momentarily. When the arm is operated, the weight of the arm can cause it to move faster than the amount of oil being supplied.

NOTE: Even after stopping the engine, the front can be lowered to the ground by operating work lever (joystick), by setting safety lever on "UNLOCK" position and turning starter switch "ON".

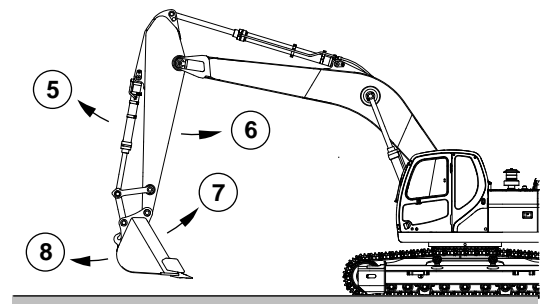

FG004952

Figure 51

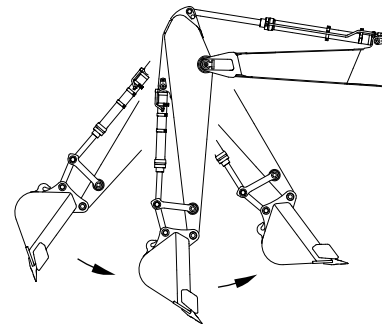

FG000120

Figure 52

Dozer Blade (Optional)

If the machine is equipped with the optional dozer blade.

The dozer blade control lever is on the left control stand. To lower blade, push lever forward: to raise blade, pull lever backwards.

Whenever dozer blade is being used to level ground, make sure to set travel speed control to "LOW SPEED". Attempting to use dozer blade in "HIGH SPEED" will cause damage to drive system.

- 9. Blade down
- 10. Blade up

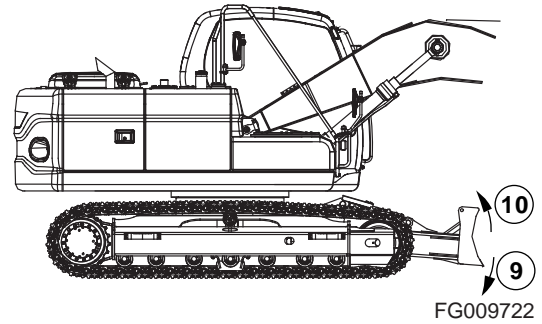

Figure 53

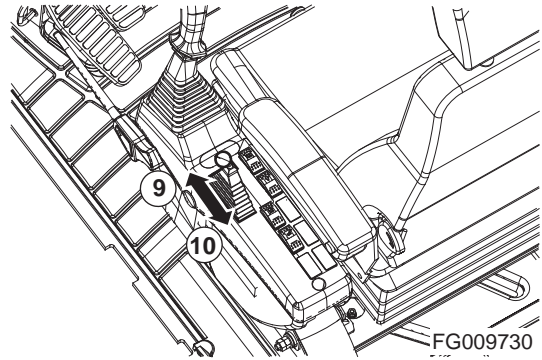

Figure 54

Two-Piece Boom (Optional)

- 11. Upper boom up
- 12. Upper boom down

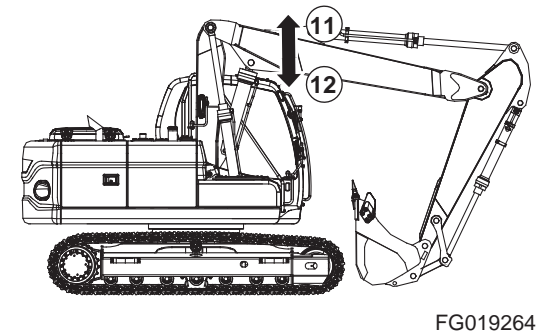

Figure 55

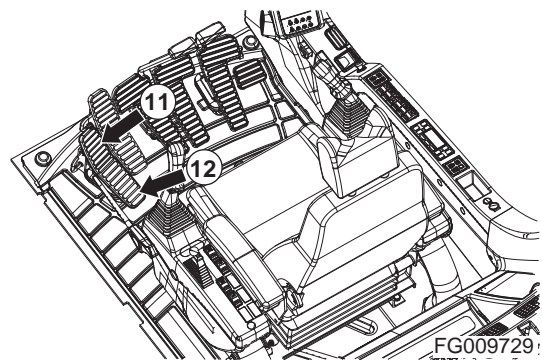

Figure 56

OPERATING PRECAUTIONS



WARNING

AVOID DEATH OR SERIOUS INJURY

Do not rest your feet on the travel pedals during normal machine operation. Unexpected machine travel can occur in this situation.

1. Before starting work, investigate terrain and soil condition. Level ground and drain area if necessary.
2. Install window guards when working where there is a possibility of falling rocks or other objects.

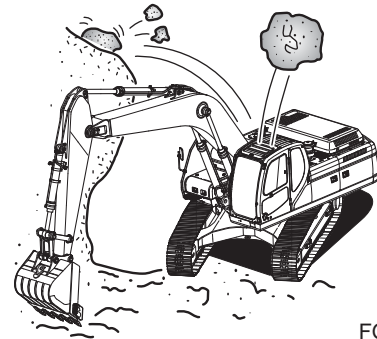

FG000374

Figure 57

3. Check strength of supported structures in advance before working on them. If insufficient, reinforce it. If any doubt exists about structural strength, refuse to operate unit.
4. It is possible that the boom, arm or bucket may come into contact with the upper or lower structure of the machine. There are digging conditions which could allow this to happen.

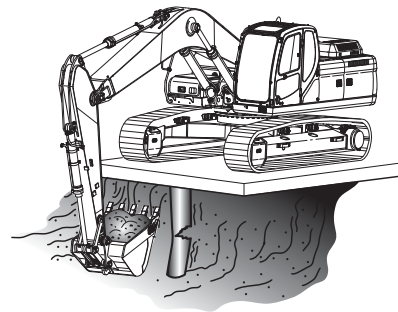

FG000375

Figure 58

5. Do not continually "bottom out" the hydraulic cylinders. Machine damage can occur if the cylinders are fully extended or retracted, example: arm cylinder fully retracted and the bucket cylinder is extended to rotate the bucket into the ground.

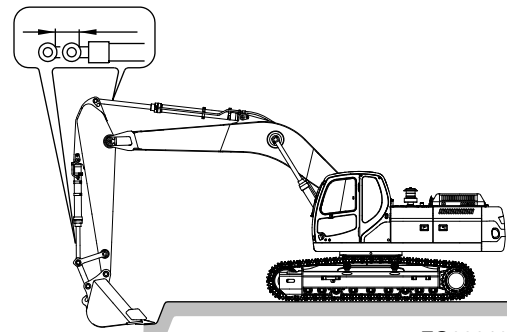

FG000132

Figure 59

6. Do not use machine travel or swing when the bucket is in the ground to provide additional breakout force. See Figure 60.

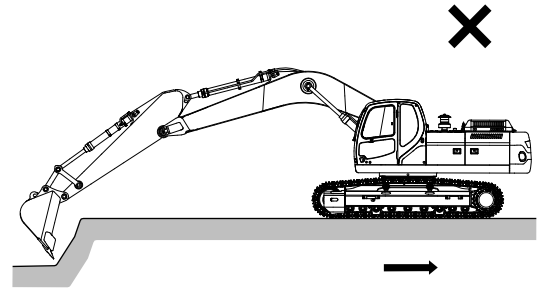

FG000134

Figure 60

7. Do not use weight of machine to provide additional breakout force. See Figure 61.
8. When working on soft or muddy ground, make sure that the machine is not sinking.

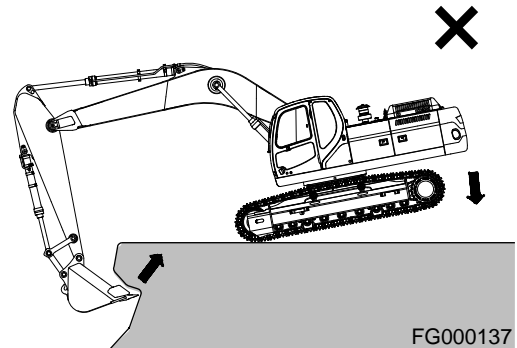

FG000137

Figure 61

9. When working close to the excavated edge, make sure that ground the machine is sitting on is solid. Keep the travel motors (1, Figure 62) to the rear. See Figure 62.

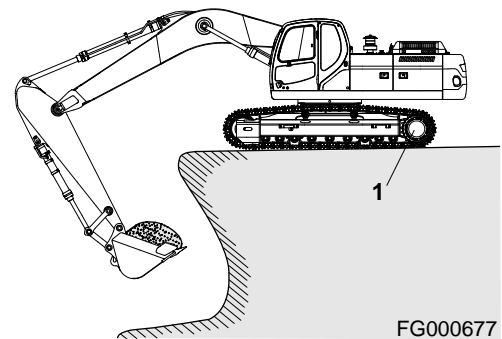

FG000677

Figure 62

10. Do not excavate underneath the machine. See Figure 63.

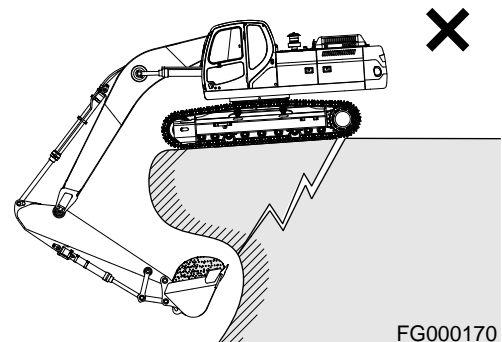

FG000170

Figure 63

11. Make sure there is adequate clearance from overhead electrical supply lines. See Figure 64.

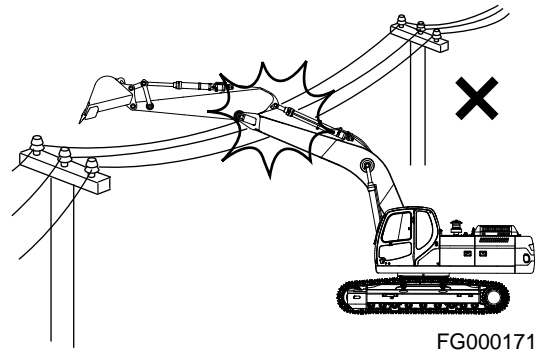

Figure 64

12. If the excavation is in an underground location or in a building, make sure there is adequate overhead clearance and there is adequate ventilation. See Figure 65.

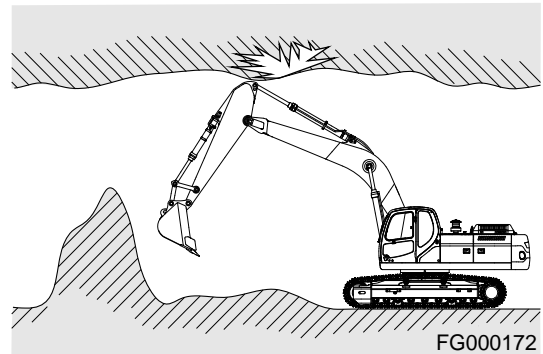

Figure 65

13. Do not use the bucket as a hammer or ramming device. This is dangerous and causes damage to the front attachment. See Figure 66.

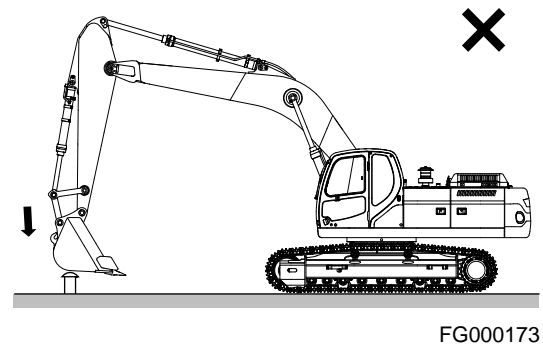

Figure 66

14. Do not dig with the excavator tracks raised. This can result in structural and mechanical failures. See Figure 67.

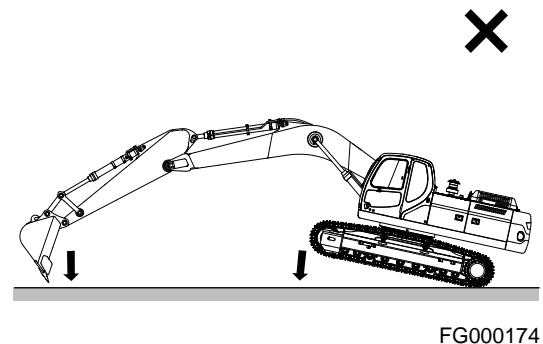

Figure 67

15. Do not operate travel lever quickly when traveling in high range.
- Avoid sudden starts.
 - When traveling in one direction come to a complete stop before reversing directions. Do not rock excavator back and forth with levers.
 - Avoid sudden stops. Return levers to neutral by hand. Do not let them snap back to neutral on their own.
16. If the optional long fronts or attachments or heavy duty front end attachments are used, the machine balance will be altered. Follow these additional operating precautions.

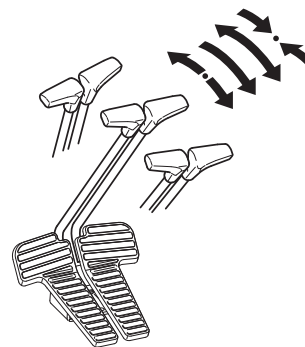

Figure 68

FG000213



WARNING

AVOID DEATH OR SERIOUS INJURY

Do not travel downhill with the front end attachments raised.

Do not travel across slopes; travel straight up or downslope.

Use extreme caution when swinging the upper frame when positioned on a slope.

Allow extra swing stopping room. The additional momentum generated by the longer or heavier front end equipment will increase the amount of time needed to stop the swing motion.

Make sure that all optional equipment has been authorized and installed properly.

17. Do not move dirt or objects by swinging the excavator into them. This can result in structural and mechanical failures.

Working in Water

IMPORTANT

When working in water, do not exceed a slope of more than 15°. If the slope is over 15°, the rear part of the upper structure will be immersed in water, resulting in radiator fan and engine ECU damage.

When working in water, do not operate in water over center of upper roller (1, Figure 70).

If swing bearing gets wet, immediately grease it until all old grease is purged from bearing.

If water gets into swing gear housing, drain water immediately by removing lower inspection cover. Apply new grease.

After working in water, purge old grease on bucket pins.

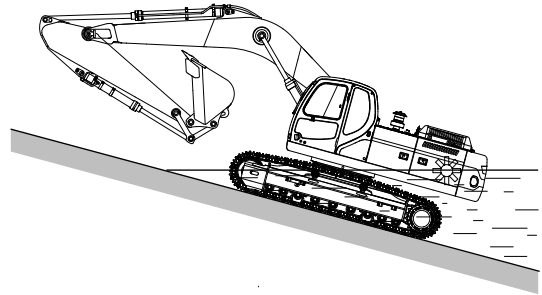

FG000179

Figure 69

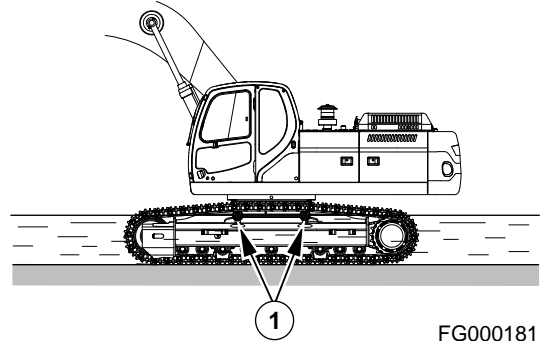

FG000181

Figure 70

PARKING EXCAVATOR



WARNING

AVOID DEATH OR SERIOUS INJURY

Park excavator on firm and level ground. Avoid parking on slopes. If excavator must be parked on a slope, block tracks and place bucket teeth in ground. See Figure 71.

1. Park excavator on firm and level ground. Lower bucket or work tool to ground as shown in Figure 72.

2. Set engine speed control dial on "LOW IDLE".

3. If you touch the operation lever unintentionally, it may create a serious accident. Before leaving operator's seat, move safety lever to "LOCK" position.

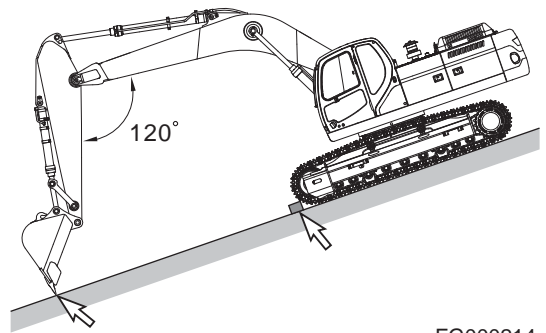

Figure 71

FG000214

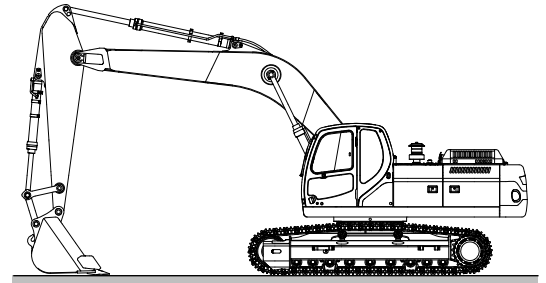

Figure 72

FG000111

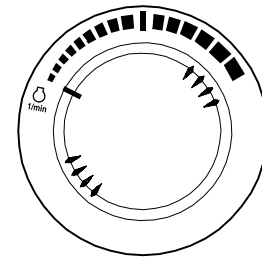

Figure 73

HAOB290L

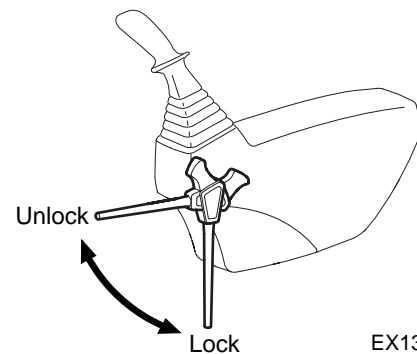

Figure 74

EX1300566

TOWING PROCEDURE



WARNING

AVOID DEATH OR SERIOUS INJURY

Never use a damaged wire rope or chain. They could brake and cause a serious accident.

Always wear gloves when handling a chain or wire rope.

When towing excavator use a wire rope or chain capable of handling the load.

Attach chain or wire rope to track frame as shown in Figure 75.

Insert protective material such as thick cloths between track frame and wire rope to prevent the wire rope from being damage.

IMPORTANT

Use shackle hook on track frame to only haul objects that weigh less than 7 metric tons (7.71 U.S. Tons). Never use it to haul objects over 7 metric tons (7.71 U.S. Tons).

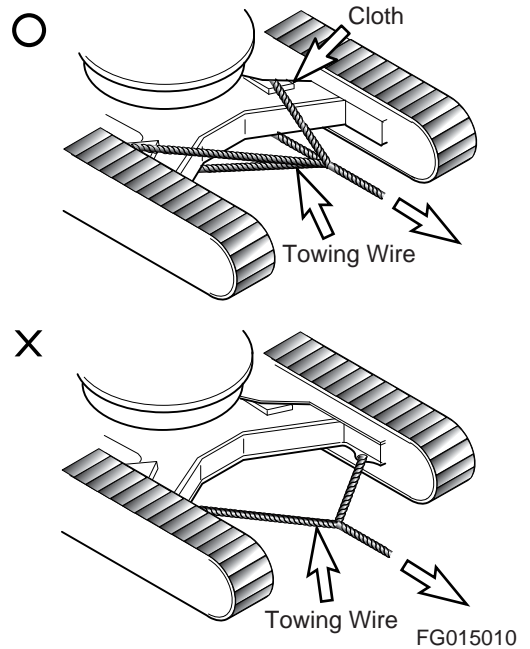

Figure 75

HYDRAULIC ATTACHMENTS (OPTIONAL)

Breaker Operation

IMPORTANT

If a hydraulic breaker and piping is installed without DOOSAN's authorization, it may create a serious malfunction which will not be covered under the excavator warranty.

Selection of Hydraulic Breaker

If a hydraulic breaker is installed, consider equipment's stability and suitability for such modification. Also, consider hydraulic oil pressure and quantity. When selecting a hydraulic breaker consult with a DOOSAN distributor or sales agency.

Hydraulic Hoses and Tubing for Breaker

1. When installing hydraulic breaker, assemble according to drawings provided with kit.
2. If breaker is taken off excavator, be sure to plug and cap all hoses and tubing to prevent contamination from entering hydraulic system.
3. Plug and cap all connectors and fittings on breaker to prevent contamination.
4. Check all hydraulic connections for signs of leaks or loose components before starting operation.

Breaker Operating Precautions

NOTE: *Hydraulic pressure and flow settings may need to be changed. Refer to the Maintenance Section of this manual for further information.*

1. Make sure to read and understand the breaker user's manual.
2. Inspect all mechanical and hydraulic connections.
3. Do not use the breaker as a hammer. See Figure 76.

Do not drop breaker from extreme heights.

The breaker is relatively heavy and drops fast. Do not drop breaker from extreme heights or damage to upper structure can result.

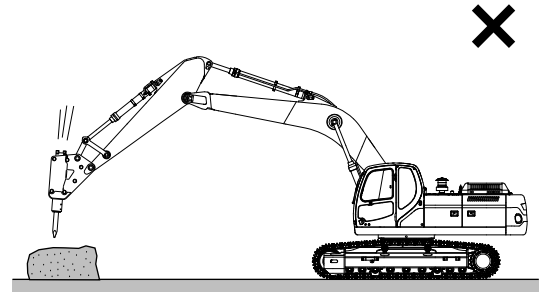

FG000188

Figure 76

4. Do not operate the breaker with the boom or arm cylinders fully extended (bottomed out). See Figure 77.

Leave over 100 mm (4 in) of clearance between rod end of cylinder and cylinder head. This will help prevent damage to cylinders during breaker operation.

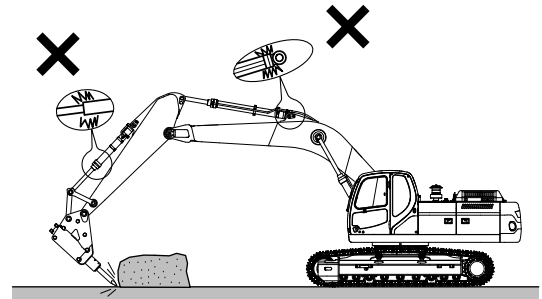

FG000191

Figure 77

5. Do not use the breaker if the hydraulic hoses vibrate excessively. See Figure 78. Check the breaker's hydraulic accumulator (1) for damage and repair as required. If excavator is operated under this condition, structural and hydraulic components can be damaged.

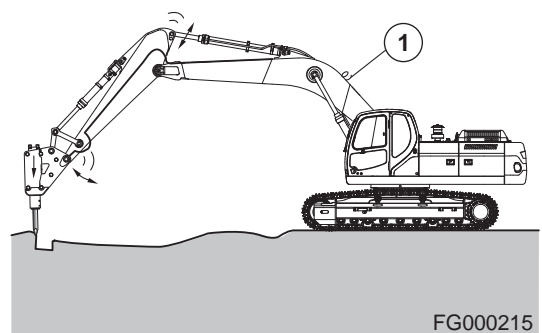

FG000215

Figure 78

- Do not allow the breaker body to go into water if not equipped for underwater operation. The breaker seal can be damaged and allow rust, foreign material or water to enter the hydraulic system and cause damage. Only insert the breaker tool into water. See Figure 79.

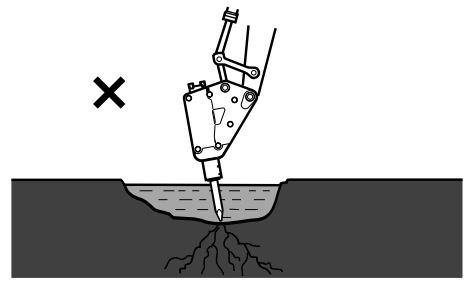

HAOB970L

Figure 79

- Do not any lifting or towing with a breaker. See Figure 80.

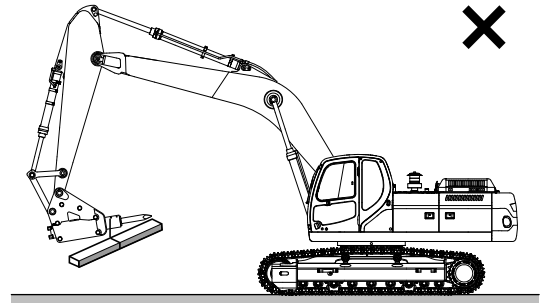

FG000207

Figure 80

- Operate the breaker only to the front and rear of the excavator. Do not use the breaker to either side of the excavator. Do not swing the breaker from side to side when operating it. See Figure 81.



WARNING

AVOID DEATH OR SERIOUS INJURY

Operating a breaker with the upper body turned 90° to the tracks can result in tipping over the machine or reduction in service life.

- Do not curl the breaker tool tip into the arm or boom when traveling or parking the excavator. See Figure 82.

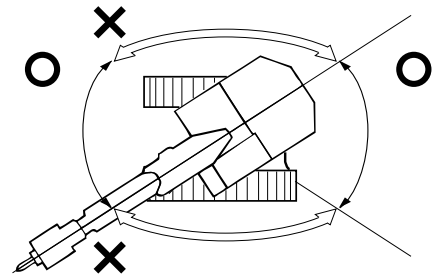

HAOB990L

Figure 81

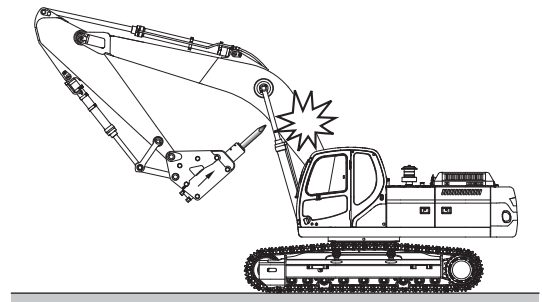

FG000216

Figure 82

To activate breaker

1. Set breaker selector switch to "II" (BREAKER) position.
2. Press lower button on top of right-hand work lever (joystick) to activate hydraulic breaker.
3. Release lower button on top of right-hand work lever (joystick) to deactivate hydraulic breaker.

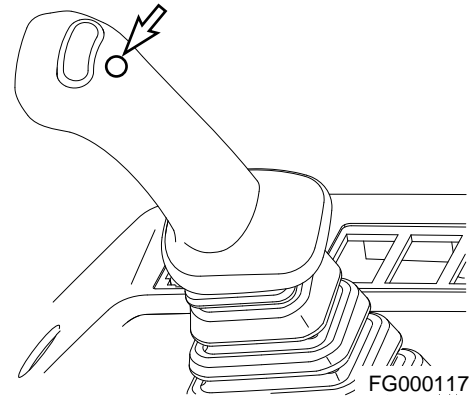
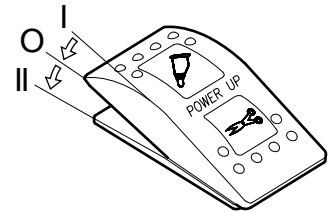

Figure 83 Right-hand Work Lever (Joystick)

Relief Valve Adjustment

1. Cap pipe on arm end, using a cap capable of handling 350.0 kg/cm^2 (5,000 psi) under the condition of disconnecting hose to hydraulic breaker.
2. Adjust pump pressure using activating the breaker, and watching the pressure displayed on the instrument panel. Press the display selector button to show digital pressure reading. (A separate pressure gauge is not required.)
3. Adjust the relief valve pressure by turning the adjustment screw of breaker relief valve. The relief valve is installed on the left side of the upper structure behind the boom. (Do not use the overload relief valve on the lower part of control valve for the breaker relief valve.)

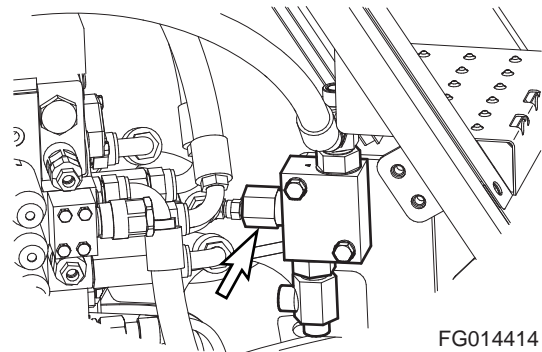

Figure 84



WARNING

AVOID DEATH OR SERIOUS INJURY

If the relief valve pressure is adjusted while the hydraulic breaker is connected, there is possibility that a high-pressure spike or setting could break a hose or pipe. Personal injury or death could result from a hydraulic hose or pipe failure.

Hydraulic Oil and Filter Service Intervals

When using a hydraulic breaker, the viscosity breakdown and contamination of hydraulic oil is faster because the work condition is more severe than during normal digging work. To prevent the hydraulic components (especially pump) from having a shortened life cycle, replace the hydraulic oil and main hydraulic oil return filter using the following schedule.

| Attachment | Operation Rate | Hydraulic Oil | Filter |
|------------------------|----------------|---------------|--|
| Bucket Work | 100% | 2,000 Hours | 250 Hours (First Replacement) 1,000 Hours (After First Replacement) |
| Hydraulic Breaker Work | 100% | 500 Hours | 100 Hours |

* These service intervals only apply, when a genuine DOOSAN oil and filter are used. If any other brands are used, the guaranteed changed interval must be reduced in half.

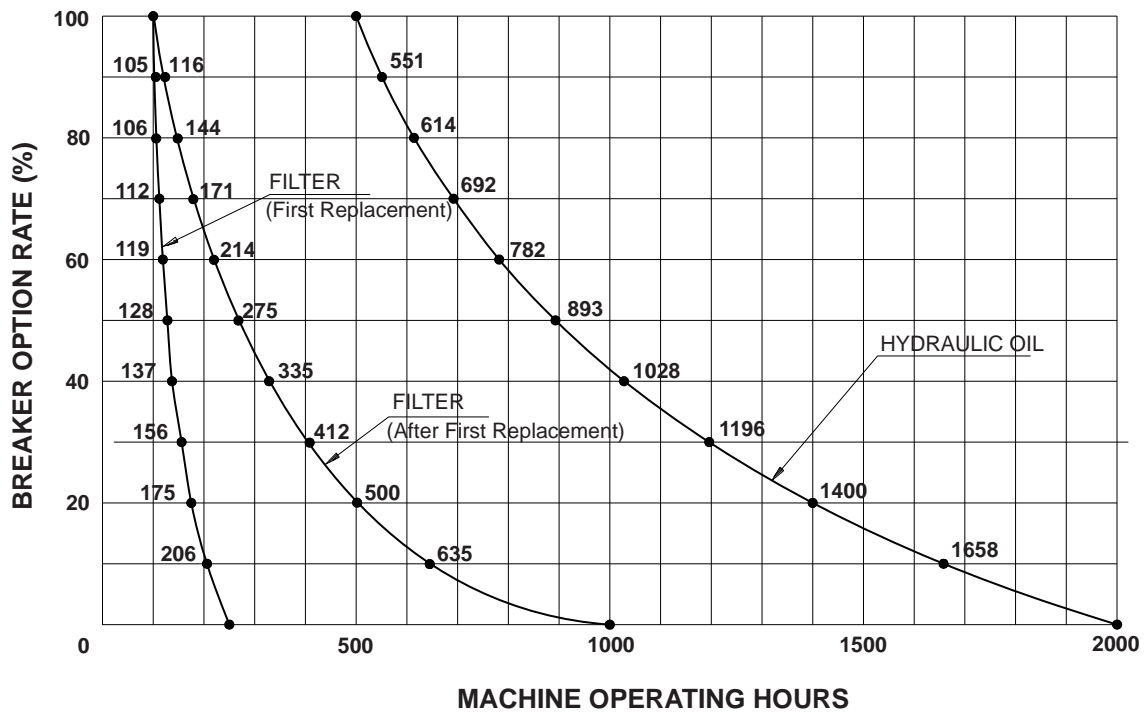

FG000767

Figure 85

NOTE: The replacement intervals of hydraulic oil and filter depend upon the amount of time the hydraulic breaker is being used. These intervals must be followed as opposed to regularly scheduled maintenance.

ADJUSTING THE PUMP FLOW

NOTE: For further information, see "Flow Control" on page 2-43.

1. On the instrument panel, press the flow control button , the flow control screen (Figure 86) will be displayed.
2. Use "UP" (▲) or "DOWN" (▼) buttons to adjust flow rate.
3. Press "SELECT" (◀) button, to return to normal display screen and save the flow rate setting.

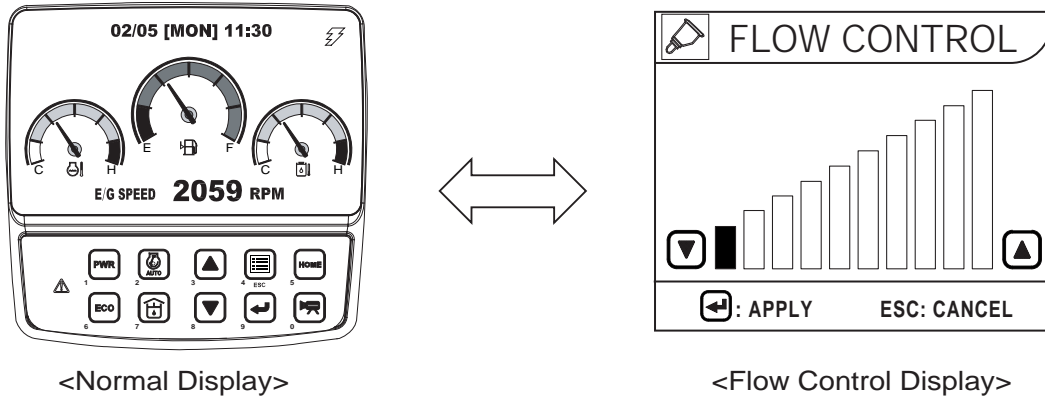

FG013831

Figure 86

| Setting | Flow Rate (l/min) |
|---------|-------------------|
| 0 | 48.5 |
| 1 | 57 |
| 2 | 66 |
| 3 | 69 |
| 4 | 78.5 |
| 5 | 90 |
| 6 | 96.5 |
| 7 | 106.5 |
| 8 | 108 |
| 9 | 114 |
| 10 | 114 |

Shear Pedal Valve (Optional)

Activating Shear with Pedal Valve

1. Select shear with the selector switch of the right panel.
2. Two-way operation is possible by rocking pedal back and forth between positions (1 and 2, Figure 87). When pedal is in its center (at rest) position, valve is in "NEUTRAL" and hydraulic oil flow is stopped.
3. Before operating attachment, be sure to check function controlled by direction of pedal movement.

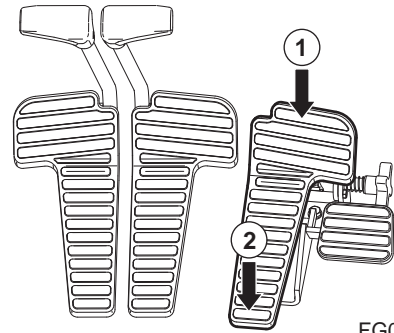

FG000402

Figure 87

Activating Breaker with Pedal Valve

1. Select "BREAKER" with selector switch on right panel.
2. Rotate knob (3, Figure 88) 120° for stopper (4, Figure 88) be fastened to (5, Figure 88).
3. In the condition that (2, Figure 87) is fastened, activate the breaker to the direction (1, Figure 87).

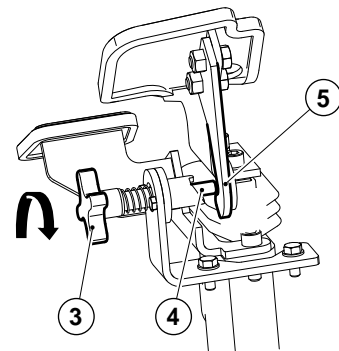

FG000403

Figure 88

Adjusting the Stopper

1. Rotate knob (3, Figure 88) in the direction of the arrow, then the pedal is activated according to the display caused by (3, Figure 88) knob rotation.



CAUTION

AVOID INJURY

When operating breaker or shear when using button on a joystick, and it is not to be controlled by the pedal, be sure to keep the stopper in the "LOCK" position in order for the pedal not to be activated.

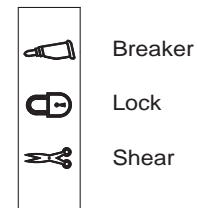
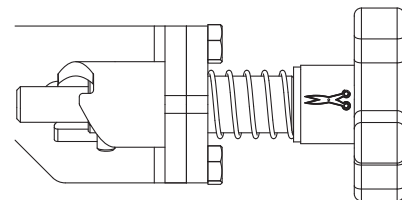

FG000434

Figure 89

Rotating Pedal Valve (Optional)

Attachment Rotating by Using the Pedal Valve

1. Pressing end (1, Figure 90) is used to turn clockwise.
2. Pressing end (2, Figure 90) is used to turn counterclockwise.

NOTE: Before activating the pedal, be sure to check the function of the attachment.

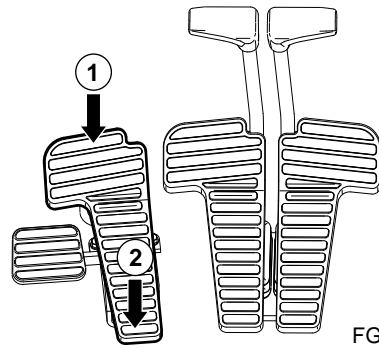

FG000405

Figure 90

Locking the Pedal

When rotating is not needed, the pedal can be locked by using the prop rod (3) locking device.

Locking is completed when the top end of the prop (3) is positioned into pedal hole.

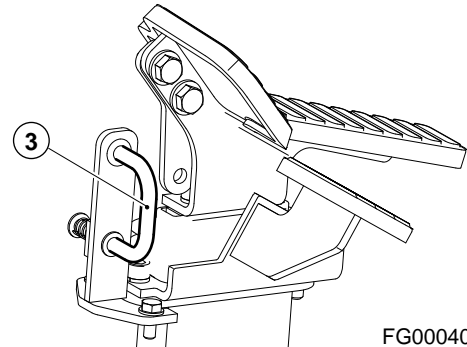

FG000406

Figure 91

- A. Location for "UNLOCKING".
- B. Location for "LOCKING".

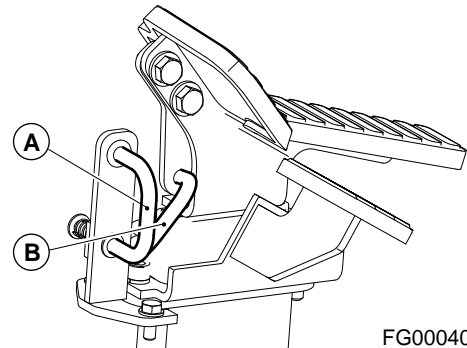

FG000407

Figure 92

Attachment Rotation Using the Left-hand Work Lever (Joystick)

For a machine equipped with an attachment that rotates, rotation is activated while one of the control buttons is being pressed on top of the left-hand work lever (joystick).

There are three buttons on top of the left-hand work lever. The left and right ones are for controlling rotation.

NOTE: The middle button is for the horn.

Left button is for counterclockwise rotation, and the right one is for clockwise rotation.

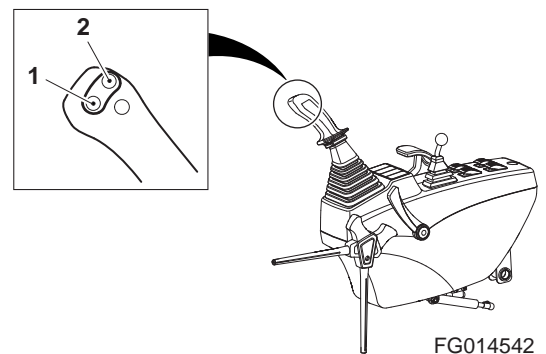

FG014542

Figure 93 Left-hand Work Lever (Joystick)

LIFTING OBJECTS

IMPORTANT

There may be local or government regulations, about the use of excavators for the lifting of heavy loads. Always contact your local and government agencies in regards to these regulations.

When this machine is used in object handling applications, the machine must be properly configured and operated properly. Ensure the following safety working devices equipped and operated.

- Lifting eye for load hooking.
- Hose burst protection on both boom and arm.
- Overload warning devices.

To prevent injury, do not exceed the rated load capacity of the machine. If the machine is not on level ground, load capacities will vary.

Short slings will prevent excessive load swing.

Use the lifting eye on the bucket that is provided to lift objects.

Always try to maintain the lifting eye (Figure 94) straight below the center line of the arm and bucket pin. In this manner the weight of the load is being primarily held only by the pin, and not by the bucket cylinder, link, and link pins.

When a lifting eye is used, the sling/lifting device must be fastened to the eye in a manner that will not allow it to come loose.

The most stable position is over the corner of the machine.

For best stability, carry a load as close to the ground and machine as possible.

Lift capacity decreases as the distance from the machine swing center line is increased.

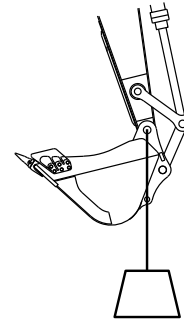

Figure 94

HAAD3830

Lifting Unknown Weight

When loads are not accurately known are to be lifted, the person responsible for the job shall ascertain that the weight of the load does not exceed the machine LOAD RATING CHART at the radius at which it is to be lifted.

It is recommended that you feel your way into any lift as a precaution against tip-over. One method is to position the boom at 90° over the side of the machine. Slowly lift the load until it clears the ground. A lift over the side is the most unstable, and as the load is swung into the front zone of the excavator it will become more stable. **DO NOT INCREASE SWING RADIUS AFTER THE LOAD IS LIFTED.**



DANGER

AVOID DEATH

If a load is picked up from the front zone and swung into the side zone, a tip-over could result causing a deadly or fatal injury.

Lifting Known Weight

The load chart is the governing factor when lifting known weights. It is recommended that you feel your way into any lift as a precaution against tip-over. Whenever possible, lift and swing payloads between the front idler area.

Pick and Carry

The machine can pick and carry payloads without added labor. We recommend when traveling with a suspended payload, you evaluate the prevailing conditions and determine the safety precautions required in each case. The following factors must be considered before attempting to pick and carry a load.

Align the boom with the forward direction of machine travel. Maintain this boom position when turning the machine. Turn only when necessary, at the slowest speed, and at a wide turning radius.

1. Use the shortest lifting radius distance possible.
2. Keep the load as close to the ground as conditions will permit.
3. Provide tag lines to prevent load from pendulating. Pendulating can cause a change in radius. A change in radius could exceed the load chart rating or cause a tip over condition.
4. Govern travel speed to suit conditions.
5. Avoid sudden starts and stops.

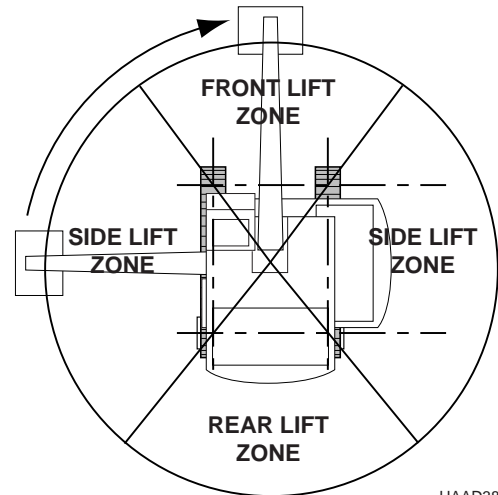

HAAD3842

Figure 95

OPERATION UNDER UNUSUAL CONDITIONS

NOTE: See *"Maintenance in Special Conditions"* on page 4-84 for other recommendations.

Operation In Extreme Cold

If machine is to be operated in extreme cold weather temperatures, certain precautions must be taken to assure continued normal operation. The following paragraphs detail checks to be made to be certain the machine is capable of operating at these temperatures.

1. Check the cooling system for correct antifreeze solution for lowest temperature expected. Carefully inspect cooling system and correct or report any leaks.
2. Keep batteries fully charged to prevent freezing. If water is added to batteries, run engine at least one hour to mix electrolyte solution.
3. Keep engine in best possible mechanical condition to assure easy starting and good performance during adverse weather.
4. Use engine oil of the proper specifications for the expected temperatures. Refer to "Lubrication Specifications" of the engine manual for details.
5. Keep fuel tank full at all times. Drain condensation from tank before and after operation. Drain and service fuel filter. To eliminate clogging of fuel filters because of wax crystal formation in the fuel, be sure that the fuel used has a cloud point specification below the lowest expected temperature.
6. Lubricate entire machine according to "Periodic Service Table and Chart" Section 4, in this manual or lubrication chart on machine.
7. Start engine and allow it to reach normal operating temperature before applying load.
 - A. If mud and ice collects and freezes on any of the moving parts while machine is idle, apply heat to thaw the frozen material before attempting to operate machine.
 - B. Operate hydraulic units with care until they have reached a temperature to enable them to operate normally.
 - C. Check all machine controls and/or functions to be sure they are operating correctly.
8. An extra outer air filter must be kept in the operator's cabin to replace element that could become iced and cause restricted air flow to engine.

9. If cold weather starting aid must be used, see "Engine Starting" COLD WEATHER START portion of this manual.
10. Clean off all mud, snow and ice to prevent freezing. Cover machine with tarpaulin if possible, keep ends of tarpaulin from freezing to ground.

Operation in Extreme Heat

Continuous operation of the machine in high temperatures can cause the machine to overheat. Monitor engine and transmission temperatures and stop machine for a cooling-off period whenever necessary.

1. Make frequent inspections and services of the fan and radiator. Check coolant level in radiator. Check grills and radiator fins for accumulation of dust, sand and insects which could block the cooling passages.
 - A. Formation of scale and rust in cooling system occurs more rapidly in extremely high temperatures. Change antifreeze each year to keep corrosion inhibitor at full strength.
 - B. If necessary, flush cooling system periodically to keep passage clear. Avoid use of water with a high alkali content which increases scale and rust formation.
2. Check level of battery electrolyte daily. Keep electrolyte above plates preventing damage to batteries. Use a slightly weaker electrolyte solution in hot climates. Dilute 1.28 specific gravity electrolyte as issued to 1.20 - 1.24 specific gravity readings at full charge. Recharge batteries whenever they reach a 1.16 specific gravity reading. Batteries self-discharge at a higher rate if left standing for long periods at high temperatures. If machine is to stand for several days, remove batteries and store in a cool place.



WARNING

AVOID DEATH OR SERIOUS INJURY

Do not store acid type storage batteries near stacks of tires; the acid fumes have a harmful affect on rubber.

3. Service fuel system as directed in "Engine Fuel System" Section 5, of this manual. Check for water content before filling fuel tank. High temperatures and cooling off cause condensation in storage drums.
4. Lubricate as specified in "Periodic Service Chart and Table" Section 4, in this manual or Lubrication Decal on the machine.

5. Do not park machine in sun for long periods of time. When practical park machine under cover to protect it from sun, dirt and dust.
 - A. Cover inactive machine with tarpaulin if no suitable shelter is available. Protect engine compartment, transmission and hydraulics from entrance of dust.
 - B. In hot, damp, climates corrosive action will occur on all parts of the machine and will be accelerated during the rainy season. Rust and paint blisters will appear on metal surfaces and fungus growth on other surfaces.
 - C. Protect all unfinished, exposed surfaces with a film of preservative lubricating oil. Protect cables and terminals with ignition insulation compound. Apply paint or suitable rust preventive to damaged surfaces to protect them from rust and corrosion.

Operation in Dusty or Sandy Areas

Operation of the machine can cause dust in almost any area. However, when in predominantly dusty or sandy areas, additional precautions must be taken.

1. Keep cooling system fins and cooling areas clean. Blow out with compressed air, if possible, as often as necessary.



WARNING

AVOID DEATH OR SERIOUS INJURY

Wear goggles when using compressed air.

2. Use care when servicing fuel system to prevent dust and sand from entering the tank.
3. Service the air cleaner at frequent intervals, check air restriction indicator daily and keep dust cup and dust valve clean. Prevent dust and sand from entering engine parts and compartments as much as possible.
4. Lubricate and perform services outlined on current lubrication chart on machine and "Lubrication Chart and Table" Section 4. Clean all lubrication fittings before applying lubricant. Sand mixed with lubricant becomes very abrasive and speeds wear on parts.
5. Protect machine from dust and sand as much as possible. Park machine under cover or protect with tarpaulin to keep dust and sand from damaging unit.

Operation in Rainy or Humid Conditions

Operation under rainy conditions is similar to that as in extreme heat procedures listed previously.

1. Keep all exposed surfaces coated with preservative lubricating oil. Pay particular attention to damaged or unpainted surfaces. Cover all paint cracks and chip marks as soon as possible to prevent corrosive effects.

Operation in Salt Water Areas

The corrosive effect of salt water and salt water spray is very extensive. When operating in salt water areas, observe the following precautions.

1. When exposed to salt water, dry machine thoroughly and rinse with fresh water as soon as possible.
2. Keep all exposed surfaces coated with preservative lubricating oil. Pay particular attention to damaged paint surfaces.
3. Keep all painted surfaces in good repair.
4. Lubricate machine as prescribed on lubrication chart on machine or "Periodic Service Table and Chart" Section 4, in this manual. Shorten lubricating intervals for parts subject to exposure to salt water, if found necessary.

Operation at High Altitudes

Normally, operation of machine at high altitudes will be as outlined in extreme cold. Before operating at high altitudes, engine fuel and air mixture may have to be adjusted according to appropriate engine manual.

1. Check engine operating temperature for evidence of overheating. The pressure cap on radiator must make a perfect seal to maintain coolant pressure in the system.

ROAD LINERS (MACHINE EQUIPPED WITH ROAD LINER)

Road Liners Information

1. Road Liner has excellent properties that are not found in steel shoes. However, if they are used in the same way as steel shoes, full use cannot be made of their advantages.
2. Be sure to operate without straining the rubber shoes in the way that condition of the jobsite and the nature of the work.

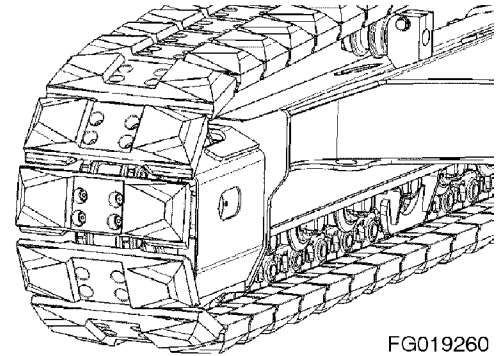

FG019260

Figure 96

Comparison for Road Liners and Metal Shoes

o : Excellent, O : Good, V : Average

| | Road Liner | Steel Shoe |
|----------------------------|------------|------------|
| Little vibration | o | V |
| Smooth travel (No creaks) | O | O |
| Little noise | o | V |
| No damage to paved surface | o | V |
| Easily damage | o | o |
| Strong drawbar pull | o | o |

1. Considering the properties of the material used, rubber shoes and road liners offer various advantages. However, their weak point is lack of strength. Therefore, it is important to understand the advantages of rubber shoes and road liners, and to follow the precautions regarding handling and prohibited work. This will extend the life of the rubber shoes and road liners to the maximum. Before using rubber shoes and road liner, always read "Using Road liners".

Warranty for Road Liners

1. It is important to inspect and maintain the tracks at the correct tension. Furthermore, these shoes must not be used near objects where they are likely to suffer damage, such as the corner of steel plates, U-shaped ditch liners, blocks, on crushed rock or the sharp edges of rocks, iron beams, or scrap iron.
2. Any damage resulting from the customer's mistaken use of the machine shall not be included in the scope of the warranty.

Using Road Liners

Prohibited Works

Do not carry out the following types of work

1. Carrying out operations and steering on crushed rock, extremely rough hard rock, steel beams, scrap iron, or near the edges of steel plates will cause damage to the rubber shoes and road liners.
2. In places such as river beds where there are large numbers of large and small boulders, the stones may get caught and damage the rubber shoes and road liners or make the shoes come off. If dozing operations are carried out when the shoes are slipping, this will reduce the life of the rubber shoes and road liners.
3. Be careful not get oil, fuel, or chemical solvent on the rubber shoes and road liners. If such a substance should get on the shoes, remove it immediately. Do not travel on road surfaces where oil has collected.

OPERATION

1. When putting the machine into long-term storage (3 months or more), store the machine indoors where it is protected from direct sunlight or rain.
2. Do not use the machine in high-temperature areas where there is burning wood, steel plates that have been left under the hot sun, or places where asphalt has been laid.
3. When the rubber parts of the road liner are so worn or broken that the head of the mounting bolts are scratched, replace the shoe immediately. If the bolts heads are broken, the bolt cannot be removed.
4. When installing road liners, always install them to all links on both sides. If they are installed to only one part of the links, their durability will be greatly reduced.

Long Life Operation

Be careful of the following points when carrying out work

1. Avoid carrying out counter rotation turns on concrete surfaces. There is danger that concrete surface will scrape off the rubber from the shoe.
2. Avoid making sudden changes in direction. This can cause premature wear or damage to the rubber shoes and road liners.
3. Avoid operating the steering when traveling over places where there is a big difference in height, drive the machine at right angles to the obstacle to prevent the shoes from coming off.
4. If the machine has been raised using the bucket. Lower it slowly.
5. Avoid doing work with materials that produce oil when crushed (soy beans, corn, or remains of vegetables squeezed for oil); or wash the machine after use.
6. Avoid handling materials that will attack the adhesion of the steel core, such as salt, ammonium sulphate, potassium chloride, potassium sulphate, or calcium superphosphate; or wash the machine after use.
7. The adhesion of the core will be attacked by salt, so avoid using the machine in coastal areas.
8. When handling salt, sugar, wheat, or soy bean, if there is any deep cut in the rubber shoes and road liners, these substances may get into the lugs or cut portion of the rubber. Always repair the rubber before use.
9. Do not carry out work that involves scraping against walls or concrete embankments.
10. Road liners slip extremely easily on snow or frozen roads. Be careful not to slip when traveling or working on slopes.
11. The properties of road liners change when working in extremely cold places, and this will reduce the life of the rubber shoes and road liners.
12. Because of the properties of rubber, use the road liners within a range of -25°C (-77°F) to $+65^{\circ}\text{C}$ ($+149^{\circ}\text{F}$).
13. When carrying out bucket operations, be careful not to damage the road liners with the bucket.

Inspection, Maintenance and Adjustment

PREVENTIVE MAINTENANCE

Routine maintenance and inspections are required to keep your machine in the correct operating condition. The following pages list the inspection intervals, the system or component checks, and location references.

NOTE: *The following pages list the service checks and their required intervals. The service cycles may need to be shortened depending on the working conditions. Extremely hot or dusty conditions will require more frequent service. Operational hours are determined by the amount of time accumulated on the engine hour meter on the control console in the cabin.*

NOTE: *Besides the normal hour meter, the multifunction gauge can be used to keep track of the hours on individual filters. See "Filter/Oil Info" on page 2-38.*

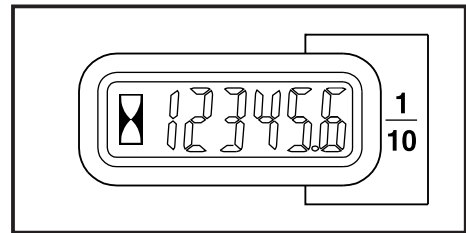

HAOA601L

Figure 1

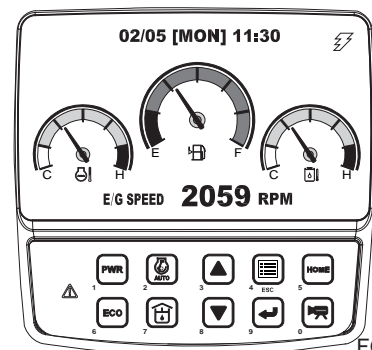

FG013662

Figure 2

Product Identification Number (PIN) Location

A PIN number, is stamped on the upper frame, under the boom foot (Figure 3). It is also stamped on the product identification plate (Figure 4 or Figure 5) on outside of the cabin on right.

NOTE: Please make note of these numbers and their locations. These will be required whenever warranty or service work is requested. Keep this number on file, incase the machine is stolen.

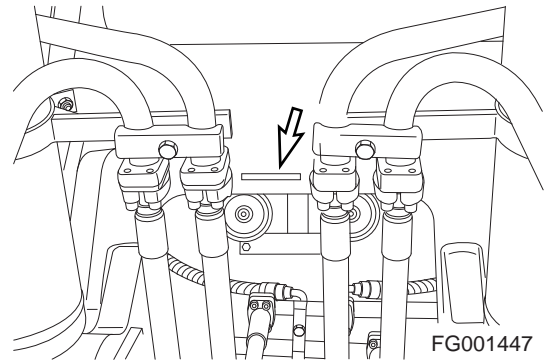
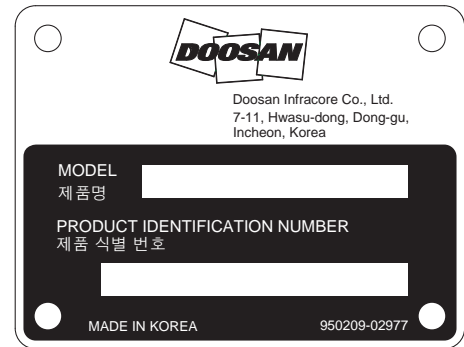
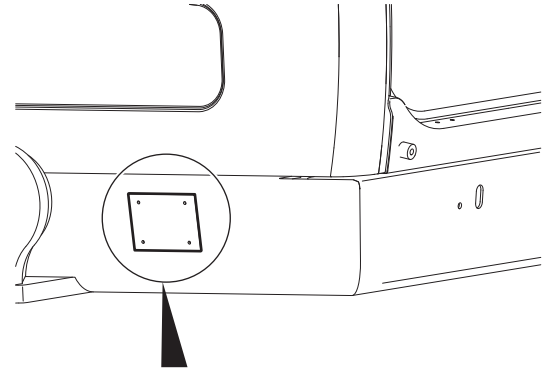
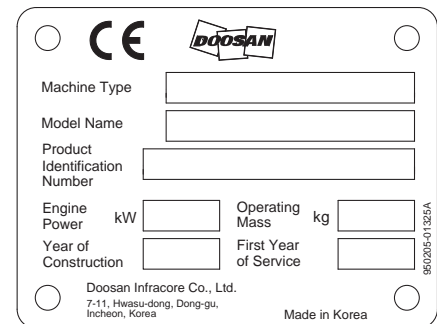

Figure 3



FG028807

Figure 4



EX1300306

Figure 5

Component Serial Numbers

There are many serial numbers on each traceable components of the machine. For example, the engine serial number is stamped on the rear left side of the engine block, above the starter. Additional engine information is described on a label (Figure 6) on the rocker cover.

Please make note of these numbers and their locations. These will be required whenever warranty service work is requested.

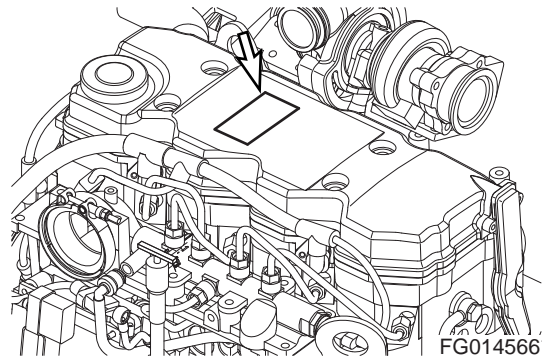

Figure 6

Safety Precautions

1. Make sure to lock out the hydraulic controls and post a notice (Warning Tag) that the machine is being serviced to prevent any unauthorized operation.
2. Make sure to clean up any fluid spills, especially around the engine.
3. Inspect all fuel lines to make sure that fittings, lines, filters and O-rings, etc., are tight and are not showing signs of wear or damage.
4. If the inspection or test procedure requires that engine be running, make sure to keep all unauthorized personnel away from the machine, and that all industry standard safety precautions are followed.

PRELIMINARY WORK MACHINE SETUP FOR MAINTENANCE

When performing maintenance specified in this manual, always park the excavator as follows.

NOTE: *Certain types of maintenance may require the machine to be positioned differently. Always return machine to this position.*

1. Park on firm and level ground.
2. Lower bucket or work tool to ground.

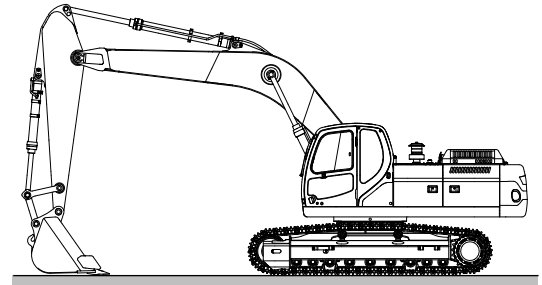

FG000111

Figure 7

3. Move safety lever to "LOCK" position.

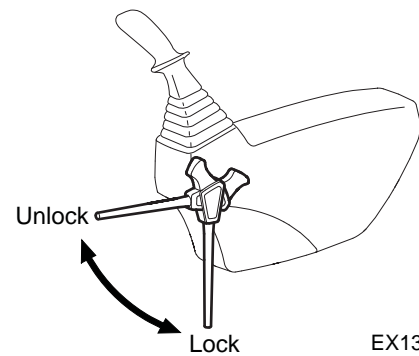

EX1300566

Figure 8

4. Allow engine to run at low idle for a minimum of five minutes to allow engine to cool. If this is not done, heat surge can occur.

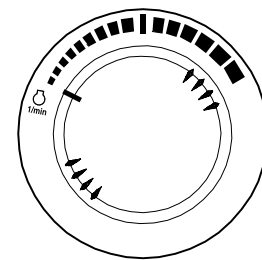

HAOB290L

Figure 9

5. Stop engine by turning key to "O" (OFF) position. Remove key from starter switch.



WARNING

AVOID DEATH OR SERIOUS INJURY

If engine must be run while performing maintenance, use extreme care. Always have one person in the cabin at all times. Never leave the cabin with the engine running.

6. Before starting maintenance work, hang up a tag, "Do Not Touch When Performing Inspection or Maintenance" on cabin door or work lever.

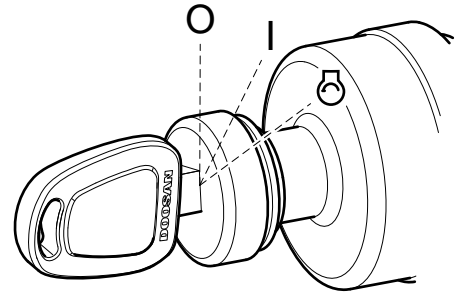

FG000175

Figure 10

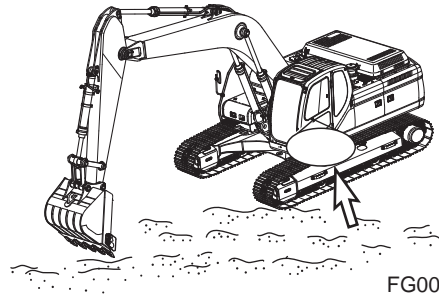

FG000401

Figure 11

TABLE OF RECOMMENDED LUBRICANTS

IMPORTANT

It is highly recommend to use DOOSAN Genuine Products or products which meet the following specifications. Using other products can damage the equipment.

NOTE: Refer to the "Description of Lubrication and Service Chart" on page 4-11 for locations.

| Reservoir | Kind of Fluid | Ambient Temperature | | | | | | | | | | | |
|--------------------|------------------|---------------------------|-----|-----|-----|-----|----|----|----|----|-----|--------|--|
| | | -58 | -40 | -22 | -4 | 14 | 32 | 50 | 68 | 86 | 104 | 122 °F | |
| | | -50 | -40 | -30 | -20 | -10 | 0 | 10 | 20 | 30 | 40 | 50 °C | |
| Engine Oil Pan | 5) Engine Oil | 2) SAE 5W-40 | | | | | | | | | | | |
| | | SAE 10W-30 | | | | | | | | | | | |
| | | 3) SAE 10W-40 | | | | | | | | | | | |
| | | 4) SAE 15W-40 | | | | | | | | | | | |
| Swing Drive Case | Gear Oil | SAE 90 and API GL5 | | | | | | | | | | | |
| Final Drive Case | | 1) SAE 80W-90 and API GL5 | | | | | | | | | | | |
| | | SAE 140 and API GL5 | | | | | | | | | | | |
| Hydraulic Oil Tank | 6) Hydraulic Oil | ISO VG. 15 | | | | | | | | | | | |
| | | ISO VG. 32 | | | | | | | | | | | |
| | | ISO VG. 46 | | | | | | | | | | | |
| | | ISO VG. 68 | | | | | | | | | | | |
| Fuel Tank | Diesel Fuel | 1) ASTM D975 No. 2 | | | | | | | | | | | |
| | | ASTM D975 No. 1 | | | | | | | | | | | |

Coolant and Water for Dilution

- The coolant has the important function of preventing corrosion and preventing freezing.
Even in areas where freezing is not an issue, use of antifreeze coolant is essential.
DOOSAN machines are supplied with DOOSAN coolant. DOOSAN coolant has excellent anticorrosion, antifreeze and cooling properties and can be used continuously for 1 year or 2,000 hours. Therefore, it is recommended to use authorized genuine DOOSAN antifreeze solution.
When using DOOSAN coolant, there is no need to use a corrosion resistor. For details, see "Engine Cooling System" on page 4-72.
- When diluting antifreeze coolant, use distilled water.
Natural water, such as a river water or well water (hard water), contains large amounts of minerals (calcium, magnesium, etc.), and this makes it easier for scale to form inside engine or radiator. Once scale is deposited inside engine or radiator, it is extremely difficult to remove.
If tap water needs to be used, refer to "Engine Cooling System" on page 4-72 for further information on standards and precautions.
- When using antifreeze, always observe precautions given in this manual.
- Antifreeze coolant is flammable, so be sure to keep it away from any flame.
- The ratio of DOOSAN coolant to water differs according to ambient temperature.
For details of ratio when mixing, see "Antifreeze Concentration Tables" on page 4-74.
DOOSAN coolant may be supplied premixed. Never add distilled water.
- If engine overheats, wait for engine to cool before adding coolant.
- If coolant level is low, it will cause overheating and corrosion problems because of air entering coolant.
- Never mix lime (hard water), salt or water contained metal material with coolant.







FLUID CAPACITIES







| Component | | Capacity |
|------------------------------|---------------------|--------------------------------|
| Engine | Oil Pan with Filter | 11 liters (5.8 U.S. gal.) |
| | Cooling System | 23 liters (6 U.S. gal.) |
| Fuel Tank | | 235 liters (62.1 U.S. gal.) |
| Hydraulic Oil | Tank Level | 85 liters (22.4 U.S. gal.) |
| | System | 161 liters (42.5 U.S. gal.) |
| Travel Reduction Gear (Each) | | 2 liters (0.53 U.S. gal.) |
| Swing Reduction Gear | | 3 liters (0.8 U.S. gal.) |

NOTE: *If the level is between lower limit line and upper limit line of the gauge, the level is correct.
If the level is low, open the cover on the tank and add hydraulic oil.*

LUBRICATION AND SERVICE CHART

Lubrication and service chart is on the inside of battery box cover. The symbols shown here are used in the lubrication and service chart on the next page.

| Symbol | Description |
|---|--|
|  | Lubrication |
|  | Gear Oil (Swing Device, Travel Device) |
|  | Engine Oil |
|  | Engine Oil Filter |
|  | Hydraulic Oil |
|  | Hydraulic Oil Return Filter |
|  | Hydraulic Oil Tank Breather |

| Symbol | Description |
|---|------------------------|
|  | Coolant |
|  | Air Cleaner Filter |
|  | Fuel Filter |
|  | Air Conditioner Filter |
|  | Drain Water |
|  | Fuel Water Separator |
|  | Fuel Cap Filter |

Description of Lubrication and Service Chart

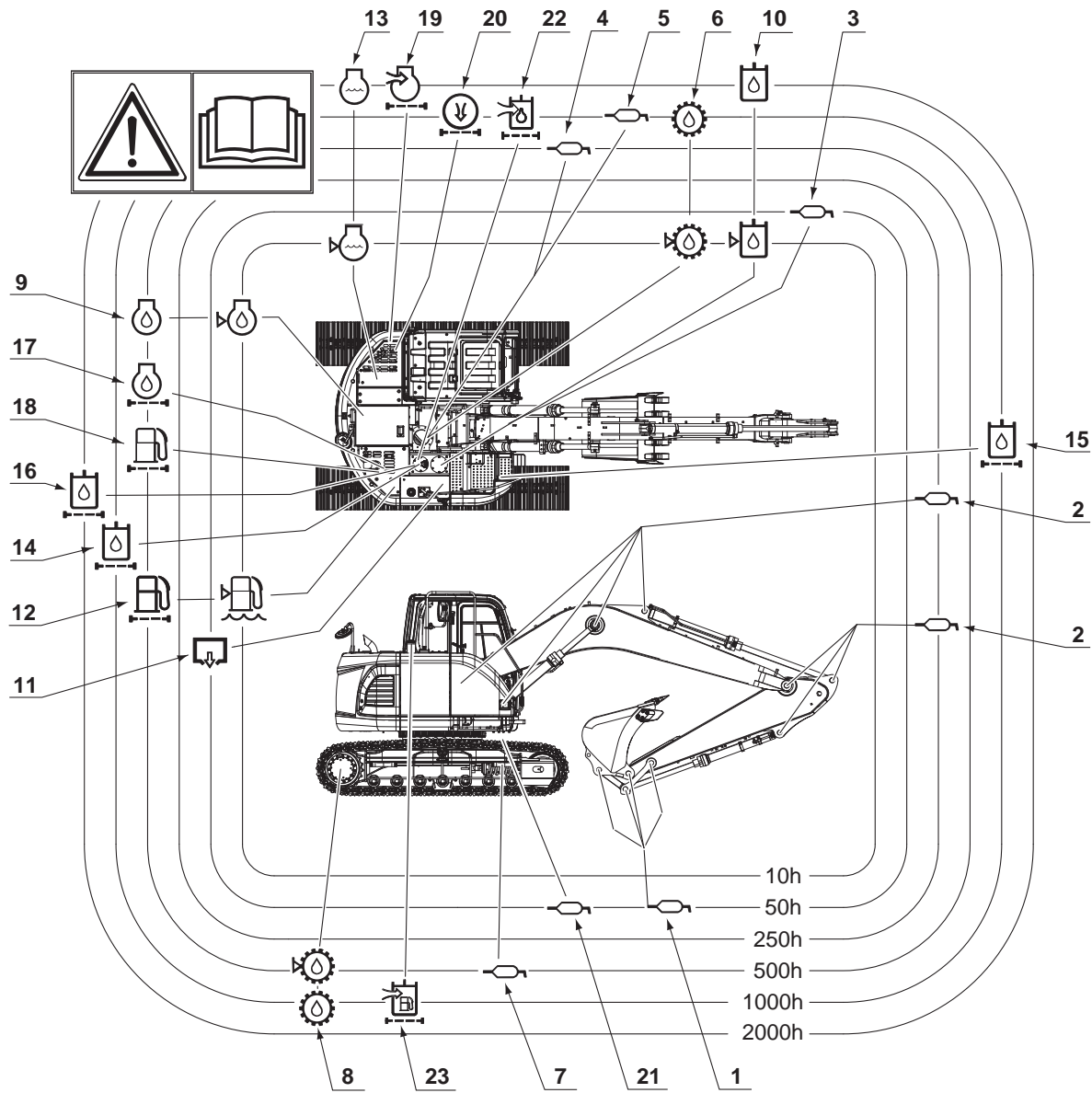

EX1300917

Figure 12

| SERVICE DATA | | | | | | | | | |
|---|--|---------------|---------|------------------|-----|-----|------|------|------|
| No. | Items to Check | Service | Qty. | Service Interval | | | | | |
| | | | | 10 | 50 | 250 | 500 | 1000 | 2000 |
| 1 | Arm, Bucket Joint Pin | Grease | 6 | F100 | W10 | | | | |
| 2 | Boom, Arm Joint Pin | Grease | 11 | F100 | | W10 | | | |
| 3 | Swing Bearing | Grease | 2 | | W10 | | | | |
| 4 | Pinion Gear (Swing) | Grease | 1 | | | | | | |
| 5 | Swing Reduction Gear | Grease | 1 | | | | | W10 | |
| 6 | Swing Reduction Gear | Gear Oil | 3 ℓ | V | | | F | | |
| 7 | Track Spring | Grease | 2 | | | | W10 | | |
| 8 | Travel Reduction Gear | Gear Oil | 2 x 2 ℓ | | | | F, V | | |
| 9 | Engine Oil | Engine Oil | 11 ℓ | V | | | | | |
| 10 | Hydraulic Oil Tank** | Hydraulic Oil | 85 ℓ | V | | | | | |
| 11 | Fuel Tank | Diesel | 235 ℓ | V | | | | | |
| 12 | Water Separator & Pre Fuel Filter (Fuel Prefilter) | Cartridge | 1 | D, V | | | | | |
| 13 | Radiator | Coolant | 23 ℓ | V | | | | | |
| 14 | Hydraulic Oil Return Filter | Element | 1 | | | F | | | |
| 15 | Pilot Filter | Element | 1 | | | F | | | |
| 16 | Hydraulic Oil Suction Strainer | Strainer | 1 | | | | | | C |
| 17 | Engine Oil Filter | Cartridge | 1 | | | | | | |
| 18 | Main Fuel Filter | Cartridge | 1 | | | | | | |
| 19 | Air Cleaner (Outer) | Element | 1 | | | | C | | |
| | Air Cleaner (Inner) | Element | 1 | | | | | | |
| 20 | Air Conditioner Filter (Outer) | Cartridge | 1 | | | | C | | |
| | Air Conditioner Filter (Inner) | Cartridge | 1 | | | | C | | |
| 21 | Dozer Blade Pin (Optional) | Grease | 6 | F100 | W10 | | | | |
| 22 | Air Breather Filter* | Element | 1 | | | | | | |
| 23 | Fuel Cap Filter | Element | 1 | | | | | | |
| V: Maintenance and Refill. | | | | | | | | | |
| C: Cleaning. | | | | | | | | | |
| D: Drain Water. | | | | | | | | | |
| F: First Time Exchange Only. | | | | | | | | | |
| F100: Every 10 Hours For First 100 Hours. | | | | | | | | | |
| W10: Every 10 Hours If Operating In Water. | | | | | | | | | |
| EG: Ethylene Glycol - DOOSAN Genuine Antifreeze Solution (Drain and replace using this interval.) See "Engine Cooling System" on page 4-72, for further explanation. | | | | | | | | | |
| : Replacement On Every Interval. | | | | | | | | | |
| NOTE: For additional service items see list of "Maintenance Intervals" on page 4-13. | | | | | | | | | |
| *: When the machine is operated under dusty work sites, the air breather filter needs to be cleaned or replaced on a regular basis even before the expected replacement date. | | | | | | | | | |
| **: If DOOSAN Genuine Oil used, hydraulic oil change interval is 4,000 hours. 4,000 oph or 2 years - make hydraulic oil sampling 2,000 oph or 1 year, change if need. | | | | | | | | | |

MAINTENANCE INTERVALS

| SERVICE ITEM | PAGE |
|---|------|
| 10 Hour/Daily Service | |
| Grease Boom, Arm and Front Attachment Pins (for first 100 hours) | 4-15 |
| Grease Dozer Blade Pin (Optional) (for first 100 hours) | 4-15 |
| Check Engine Oil Level | 4-16 |
| Check Level of Hydraulic Oil Tank | 4-17 |
| Check for Leaks in Hydraulic System | 4-18 |
| Check Fuel Level | 4-19 |
| Check for Leaks in Fuel System | 4-19 |
| Check Water Separator & Pre Fuel Filter (Fuel Prefilter) and Drain Water As Required | 4-20 |
| Check Oil Level of Swing Reduction Device | 4-21 |
| Clean Dust Net in Front of Oil Cooler and Intercooler | 4-22 |
| Check Cooling System and Refill As Required | 4-22 |
| Check Level of Window Washer Liquid | 4-23 |
| Inspect Bucket Teeth and Side Cutters for Signs of Wear | 4-23 |
| Inspect Cooling Fan Blade | 4-24 |
| Check Air Intake System | 4-24 |
| Inspect Seat Belt for Proper Operation | 4-24 |
| Inspect Structure for Cracks and Faulty Welds | 4-25 |
| Check Operation of All Switches | 4-25 |
| Check the Operation of Pilot Cutoff Switch | 4-25 |
| Check Operation of All Exterior Lights, Horn and Control Console Indicator and Monitor Lights | 4-26 |
| Start Engine, Check Starting Ability, and Observe Exhaust Color at Start-up and at Normal Operating Temperature. Listen for Any Abnormal Sounds | 4-27 |
| Check Operation of All Controls | 4-27 |
| 50 Hour / Weekly Service | |
| Perform All Daily Service Checks | 4-28 |
| Grease Arm and Front Attachment Pins | 4-28 |
| Grease Swing Bearing | 4-29 |
| Grease Dozer Blade Pin (Optional) | 4-30 |
| Drain Water and Sediment from Fuel Tank | 4-30 |
| Check Engine Fan Belt for Cracks, Wear and Correct Tension (After First 50 Hours) | 4-30 |
| Inspect Track Assemblies for Proper Tension and Loose, Worn or Damaged Parts (Links, Shoes, Rollers, Idlers) | 4-30 |
| 250 Hour / Monthly Service | |
| Perform All Daily and 50 Hour Service Checks | 4-31 |
| Grease Arm and Front Attachment Pins | 4-31 |
| Check Engine Fan Belt Tension | 4-33 |
| Check Engine Fan Belt Wear | 4-34 |
| Change Breaker Filter (Optional) | 4-35 |
| Replace Hydraulic Oil Return Filter (After First 250 Hours) | 4-36 |
| Change Pilot Filter (After First 250 Hours) | 4-36 |
| Inspect Pins and Bushings of Front End Attachments for Signs of Wear | 4-36 |
| Check Fluid Levels in Batteries | 4-36 |

| SERVICE ITEM | PAGE |
|--|-------------|
| Inspect for Any Loose or Missing Nuts and Bolts | 4-36 |
| Inspect Fuel System Hose Clamps | 4-36 |
| 500 Hour / 3 Month Service | |
| Perform All Daily, 50 and 250 Hour Service Checks | 4-37 |
| Grease Swing Gear and Pinion | 4-37 |
| Change Engine Oil and Filter | 4-38 |
| Clean Air-Conditioning Outer Filter | 4-39 |
| Check and Clean Air-Conditioning Inner Filter | 4-40 |
| Clean Radiator, Oil Cooler, Intercooler, Fuel Cooler and Air Conditioner Condenser Core | 4-41 |
| Clean Outer Filter of Air Cleaner | 4-42 |
| Change of Water Separator & Pre Fuel Filter (Fuel Prefilter) | 4-44 |
| Change Main Fuel Filter | 4-45 |
| Check Oil Level in Travel Reduction Device (One on Each Side of Unit) | 4-46 |
| Change Oil in Travel Reduction Device (One on Each Side of Unit) (After First 500 Hours) | 4-46 |
| Change Swing Reduction Device Oil (Drain and Refill After First 500 Hours) | 4-46 |
| 1,000 Hour / 6 Month Service | |
| Perform All Daily, 50, 250 and 500 Hour Service Checks | 4-47 |
| Grease Swing Reduction Device | 4-47 |
| Change Air Breather Filter | 4-47 |
| Replace Hydraulic Oil Return Filter | 4-48 |
| Change Pilot Filter | 4-49 |
| Change Oil in Travel Reduction Device (One on Each Side of Unit) | 4-50 |
| Change Swing Reduction Device Oil | 4-51 |
| Change Air-Conditioning Outer Filter | 4-52 |
| Change Air-Conditioning Inner Filter | 4-53 |
| Check Air Conditioner Refrigerant | 4-54 |
| Change Fuel Cap Filter | 4-55 |
| Check and Adjust Engine ** | 4-56 |
| 2,000 Hour / Yearly Service | |
| Perform All Daily, 50, 250, 500 and 1,000 Hour Service Checks | 4-57 |
| Replace Outer and Inner Air Cleaner Elements | 4-57 |
| Change Radiator Coolant | 4-58 |
| Hydraulic Oil Exchange and Suction Strainer Cleaning | 4-60 |
| Check Alternator and Starter** | 4-62 |
| Check All Rubber Antivibration Shock Mounts | 4-62 |
| Perform and Record Results of Cycle Time Tests | 4-62 |
| Inspect Machine to Check for Cracked or Broken Welds or other Structural Damage | 4-62 |
| Check, Adjust Valve Clearance ** | 4-62 |
| Check Head Bolt Torques | 4-62 |
| 4,000 Hour / Biennial Service | |
| Major Parts - Periodic Replacement | 4-63 |
| 12,000 Hour / Six Year Service | |
| Hose In-service Lifetime Limit (European Standard ISO 8331 and EN982 CEN) | 4-64 |

** These checks need to be completed by an authorized DOOSAN dealer.

10 HOUR / DAILY SERVICE

Grease Boom, Arm and Front Attachment Pins (for first 100 hours)



AVOID DEATH OR SERIOUS INJURY

Do not remove grease fitting until pressure is entirely bled off by loosening grease fitting slowly to avoid fatal wound.

Let anybody never be in the blowing direction.

Be careful to any kinds of works for nipples and hydraulic line plugs.

Grease every 10 hours for first 100 hours and every 50 or 250 hours thereafter (See page 4-28).

NOTE: *If the unit has been running or working in water the front attachment must be greased on a 10 hour/daily basis.*

Grease Dozer Blade Pin (Optional) (for first 100 hours)

NOTE: *Grease it per 10 hours during initial period of 100 hours after buying your new machine, after which period grease it per 50 hours.*

NOTE: *In case of performing work underwater, grease it per 10 hours irrespective of elapsed period.*

1. Lower dozer blade to the ground.
2. Inject grease at total 6 points by 3 points per dozer cylinder by means of using grease gun.

Neatly remove old grease that has leaked out after greasing.

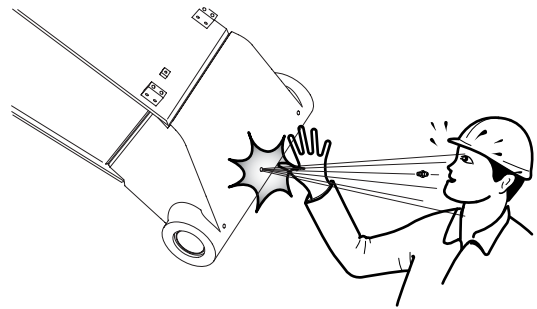

FG000500

Figure 13

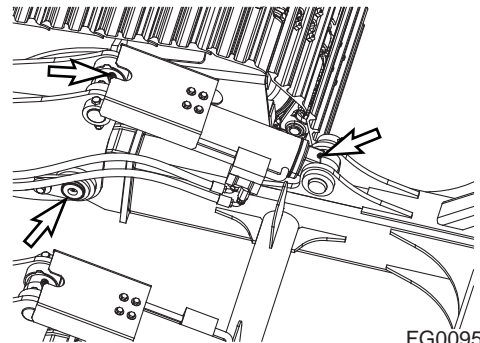

FG009564

Figure 14

Check Engine Oil Level



WARNING

AVOID DEATH OR SERIOUS INJURY

Allow the engine to cool before checking the oil level to avoid burns by touching hot engine parts.

NOTE: When checking level using a dipstick always remove and wipe it clean before making final level check.

1. Stop engine and wait for fifteen minutes. This will allow all oil to drain back to oil pan.
2. Remove dipstick (1, Figure 15) and wipe the oil off with a clean cloth.
3. Insert dipstick fully in the oil gauge tube, then take it out again.
4. Engine oil level must be between "HIGH" and "LOW" marks on dipstick.

NOTE: If oil is above "HIGH" mark on dipstick, some must be drained to return oil to proper level.

5. Add oil through engine oil fill cap (2, Figure 15), if the oil level is below the "LOW" mark.

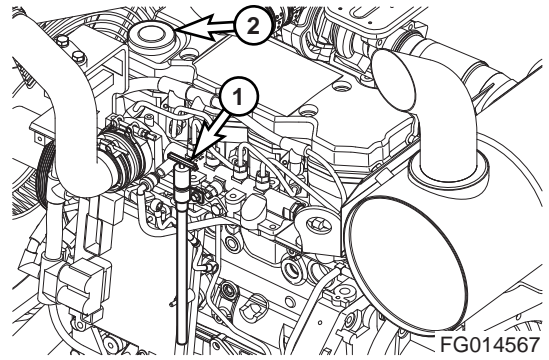

Figure 15

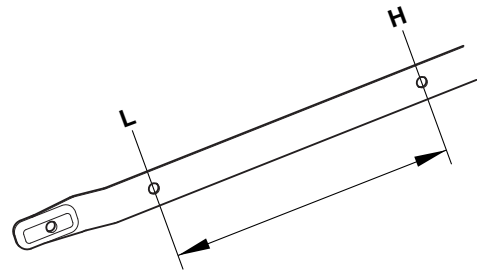

Figure 16

Check Level of Hydraulic Oil Tank



WARNING

AVOID DEATH OR SERIOUS INJURY

The hydraulic oil will be hot after normal machine operation. Allow the system to cool before attempting to service any of the hydraulic components.

The hydraulic tank is pressurized. Turn the breather cap slowly to allow the pressurized air to vent. After the pressure has been released, it is safe to remove either the fill cap or service covers.

1. Park machine on firm and level ground. Lower boom and position bucket on ground as shown in Figure 17.
2. Move engine speed to "LOW IDLE".

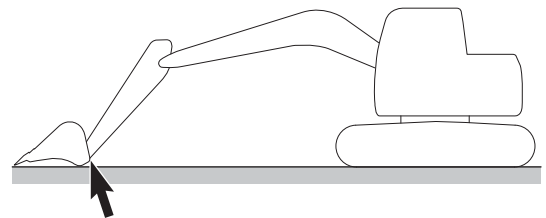

EX1300562

Figure 17

3. Move safety lever to "LOCK" position.
4. Check level gauge through right glass of cabin. Oil level must be between marks on sight gauge.

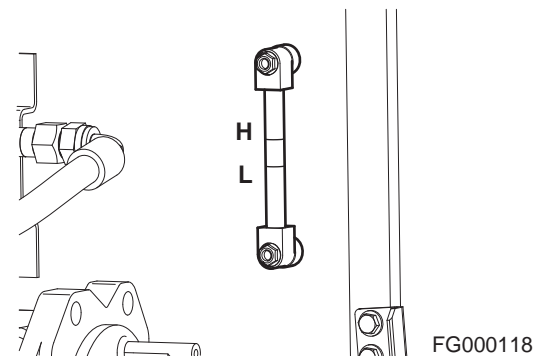

Figure 18

5. If the level is below "L" mark add oil.
 - A. Stop engine.
 - B. The hydraulic tank is pressurized. Lift the breather cap slowly to allow the pressurized air to vent.
 - C. Remove the upper cover of the hydraulic tank and add oil.

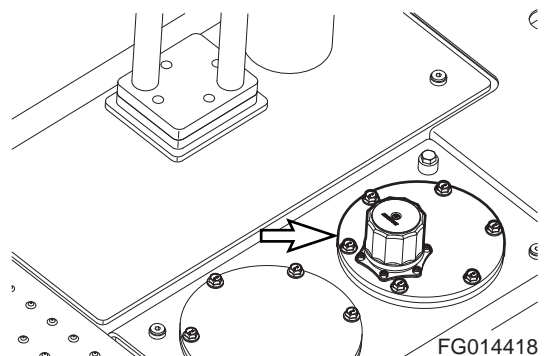

Figure 19

IMPORTANT

Do not fill above "H" mark on sight gauge. Overfilling can result in damage to equipment and oil leaking from hydraulic tank because of expansion.

6. If oil level is above the "H" mark drain oil.
 - A. Stop engine and wait for the hydraulic oil to cool down.
 - B. Drain the excess oil from drain plug (Figure 20) at the bottom of the tank into a suitable container, using a hose connected to the valve.

NOTE: *Dispose of drained fluids in compliance with all applicable environmental laws and regulations.*

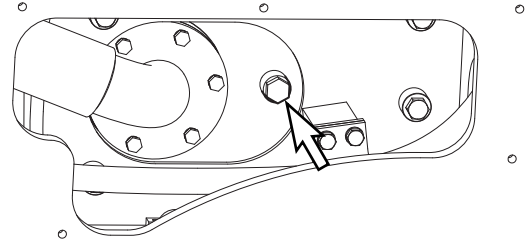

FG014419

Figure 20

Check for Leaks in Hydraulic System

1. Perform a daily walk-around inspection to make sure that hoses, piping, fittings, cylinders and hydraulic motors are not showing any signs of leakage. If any is noted, determine the source of the leak and repair.

Check Fuel Level



WARNING

AVOID DEATH OR SERIOUS INJURY

Use extreme safety precautions while refueling to prevent explosions or fire.

Immediately clean up any split fuel.

1. At end of each work day, fill fuel tank. Add fuel through fuel fill tube (1, Figure 21). When working at a temperature of 0°C (32°F) or higher, use ASTM No. 2-D or its equivalent. At temperatures below 0°C (32°F) use ASTM No. 1-D or its equivalent.
2. Make sure that fuel fill hose is grounded to the excavator before fueling begins.
3. Check the amount of fuel in the tank by observing the fuel tank sight gauge (2, Figure 21).

NOTE: See "Fluid Capacities" on page 4-9 for capacity.

4. The excavator may be equipped with the optional battery operated fuel fill pump. The pump assembly is in the hydraulic pump compartment. Put the suction hose of the pump into the fuel resupply tank. Turn the switch in the pump compartment "ON", and the fuel will be pumped into the excavator fuel tank.

NOTE: See "Fuel Transfer Pump (Optional)" on page 4-75, for further information.

5. Do not overfill the tank.
6. Securely tighten cap after fueling.

NOTE: If breather holes (3, Figure 22) in cap are clogged, a vacuum may form in the tank preventing proper fuel flow to engine. Keep holes in fuel cap clean.

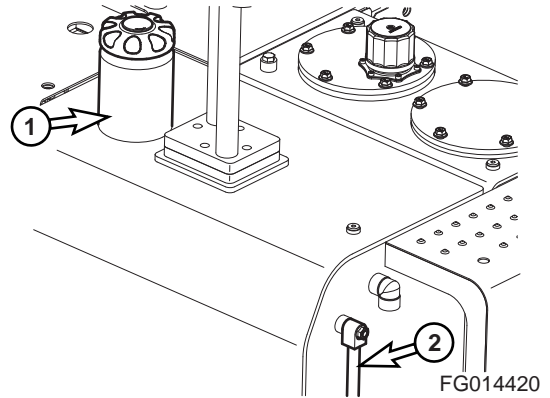

Figure 21

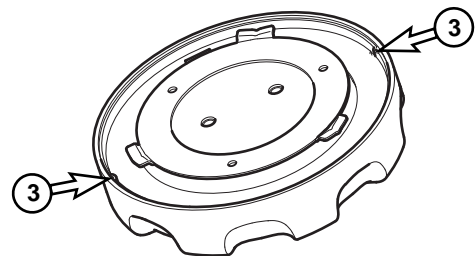

Figure 22

Check for Leaks in Fuel System

1. Perform an inspection of the engine compartment to verify that fuel system is not leaking. If any is noted, determine the source of the leak and repair.

Check Water Separator & Pre Fuel Filter (Fuel Prefilter) and Drain Water As Required

NOTE: *If water in fuel warning light (Figure 23) on instrument panel comes "ON", drain the collected water in fuel prefilter.*

1. A fuel prefilter is inside the right rear side access door.
2. Open the access door on right rear side of the machine.

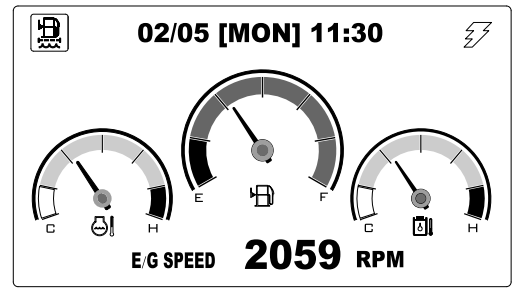

FG013894

Figure 23

3. It is necessary to drain the collected water if the bowl is full of water or sediment.
4. Position a small container under fuel prefilter. Drain water or sediment by opening drain valve (2, Figure 25) on bottom of bowl (1).

NOTE: *Dispose of drained fluids in compliance with all applicable environmental laws and regulations.*

5. Close drain valve.

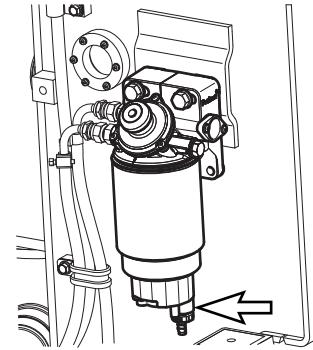

FG014421

Figure 24

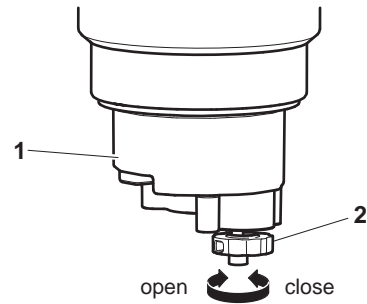

FG000438

Figure 25

Check Oil Level of Swing Reduction Device



AVOID DEATH OR SERIOUS INJURY

The gear oil is very hot after the machine has been operating. Shut all systems down and allow them to cool. Before fully removing any motor case inspection port plug, etc., loosen the plug slightly to allow pressurized air to escape.

NOTE: When checking level using a dipstick always remove and wipe it clean before making final level check.

1. Remove dipstick (1, Figure 26) and wipe the oil from the dipstick with a cloth.
2. Insert dipstick (1, Figure 26) fully into dipstick tube.

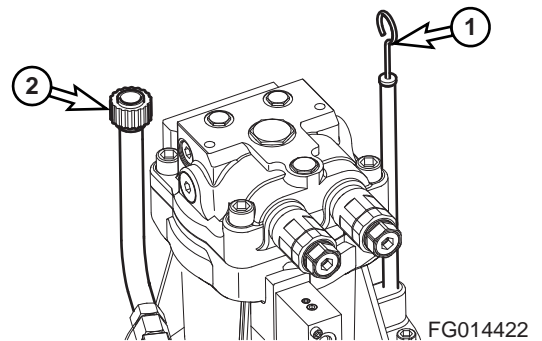

Figure 26

3. When dipstick is pulled out, oil level must be between "HIGH" and "LOW" marks on dipstick.

NOTE: If oil is above "HIGH" mark on dipstick, some must be drained to proper level.

4. If the oil does not reach the "L" mark on the dipstick, add oil through fill port (2, Figure 26).

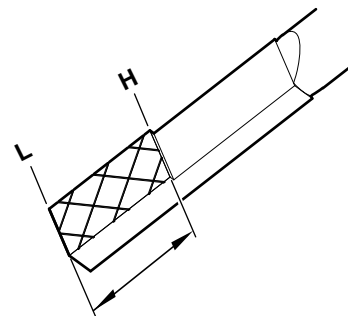

Figure 27

5. If the oil level exceeds the "H" mark on the dipstick, open cap (3, Figure 28) of drain valve and connect hose (4) to the valve. Drain the excessive oil into a suitable container.

NOTE: Dispose of drained fluids in compliance with all applicable environmental laws and regulations.

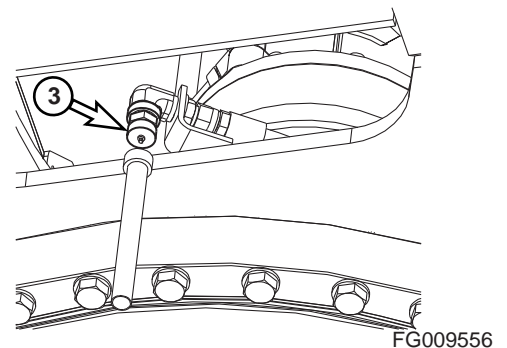

Figure 28

Clean Dust Net in Front of Oil Cooler and Intercooler

IMPORTANT

If running excavator in dusty area, check dust net everyday and clean it if dirty.

WARNING

AVOID DEATH OR SERIOUS INJURY

If using compressed air or water to clean the dust net, make sure that proper eye protection is worn.

1. Loosen the wing bolt(s) and remove dust net.
2. Clean with compressed air or water.

Check Cooling System and Refill As Required

WARNING

AVOID DEATH OR SERIOUS INJURY

Allow the engine to cool before releasing the radiator cap. Make sure to loosen the cap slowly to release any remaining pressure.

Radiator cleaning is performed while the engine is running. Take extreme caution when working on or near a running engine. Make sure to lock out and tag the controls notifying personnel that service work is being performed.

Do not remove radiator cap unless it is required. Observe the coolant level in the coolant recovery tank.

NOTE: *Do not mix ethylene glycol and propylene glycol antifreeze together.*

1. When the engine is cold, remove the radiator cap and check the coolant level inside the radiator. Do not rely on the level of coolant in the coolant recovery tank. Refill radiator as required. Refer to coolant concentration table. (See page 4-74)
2. Check to make sure that the coolant transfer line from the coolant recovery tank to the radiator is free and clear of obstructions, or not pinched.
3. Observe the level of coolant in the coolant recovery tank. The normal cold engine fluid level must be between "FULL" and "LOW" marks on tank.
4. If the coolant is below the "LOW" mark, add genuine part of 50% concentration coolant to the tank.

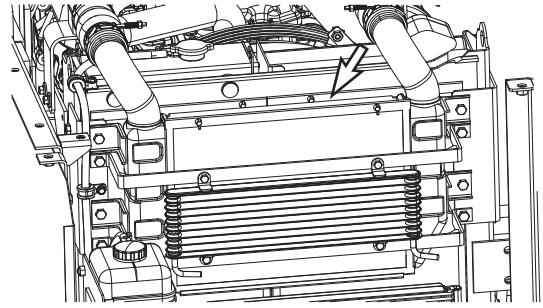

Figure 29

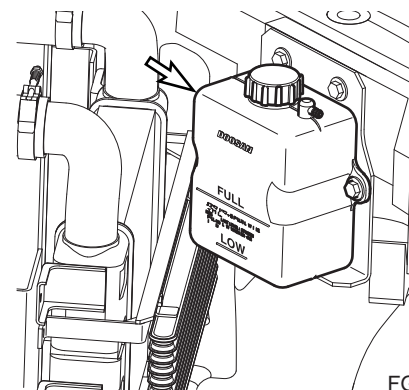
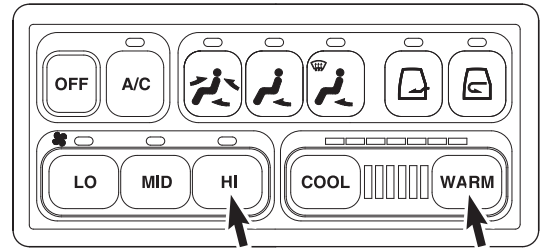

Figure 30

NOTE: When refill or replace coolant, select "heater-full hot" mode to fully open the water valve.

Coolant will then flow into the heater's core to prevent air from being trapped in it.



EX1502246

Figure 31

Check Level of Window Washer Liquid

1. Open left rear access door and check fluid level in windshield washer tank.
2. Open fill cap and add fluid.

NOTE: Use a washer liquid that is rated for all seasons. This will prevent freezing during cold weather operation.

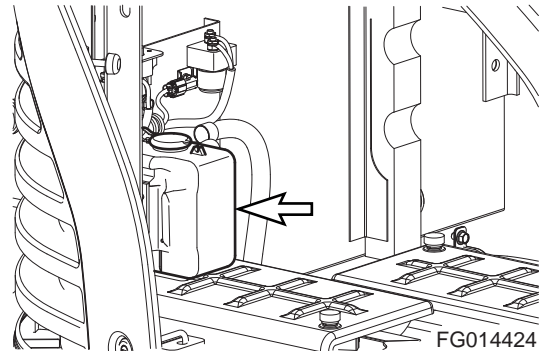

FG014424

Figure 32

Inspect Bucket Teeth and Side Cutters for Signs of Wear

1. On a daily basis, inspect the bucket teeth to make sure that tooth wear or breakage has not developed.
2. Do not allow the replaceable bucket teeth to wear down to the point that bucket adapter is exposed. See Figure 33.

NOTE: These instructions are only for DOOSAN OEM buckets. If you are using other manufacturers' buckets, refer to their specific instructions.

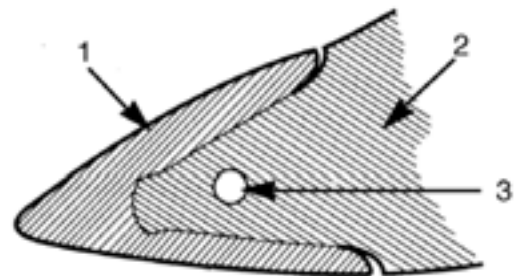

HAOE870P

Figure 33

| Reference Number | Description |
|------------------|-------------|
| 1 | Point |
| 2 | Adapter |
| 3 | Pin |

Inspect Cooling Fan Blade



AVOID DEATH OR SERIOUS INJURY

Personal injury can result from a fan blade failure. Never pull or pry on the fan. This can damage the fan blade(s) and cause fan failure.

1. An inspection of the cooling fan is required daily. Check for cracks, loose bolts, bent or loose blades, and for contact between the blade tips and the fan shroud. Check the fan to make sure it is securely mounted. Tighten the bolts if necessary. Replace any fan that is damage.

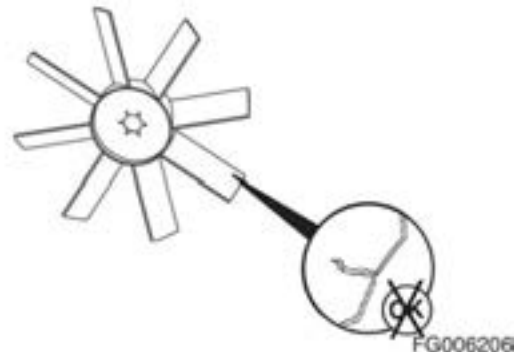

Figure 34

Check Air Intake System



AVOID INJURY

Hot engine components can cause burns.

Avoid contact with hot engine components

1. Park the machine on a level surface, lower the attachment to the ground, move safety lever to "LOCK" position, and stop engine.
2. Check the engine intake hose, and hose bands for damage and tightness.
3. If damaged, wrinkled, or loose, replace or retighten or contact your nearest DOOSAN dealer.

IMPORTANT

Severe engine damage will result from running with unfiltered air.

Do not operate engine if any leaks or defects are found on air intake system.

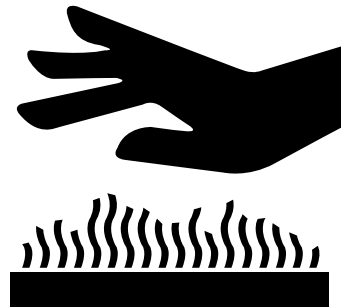

Figure 35

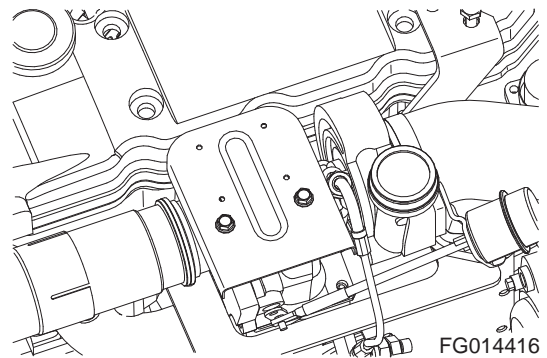

Figure 36

Inspect Seat Belt for Proper Operation

See "Seat Belt" on page 1-35 for further information.

Inspect Structure for Cracks and Faulty Welds

1. During the daily walk-around inspection and when greasing the machine, look for any visible damage to the machine. Repair or replace any damaged parts before operating the machine.

Check Operation of All Switches

1. Verify the working condition of all switches before starting the engine.

Check the Operation of Pilot Cutoff Switch

A pilot cutoff switch has a pivoting safety lever that deactivates the work group, swing and travel control functions.

When the safety lever is moved down into "LOCK" position, the work group, swing and travel control functions are deactivated.

When the safety lever is moved up into "UNLOCK" position, the work group, swing and travel control functions can be operated.



WARNING

AVOID DEATH OR SERIOUS INJURY

The **PILOT CUTOFF SWITCH** (safety lever) must deactivate the work group, swing and travel control functions when the safety lever is moved down into "LOCK" position.

Contact your **DOOSAN** distributor immediately if the controls do not deactivate. **DO NOT MODIFY THE SYSTEM.**

Inspection and Maintenance of the Pilot Cutoff Switch

1. Check for and keep bystanders away from the work area. Sit in operator's seat and fasten seat belt.
2. Start engine and move safety lever up into "UNLOCK" position.
3. Operate the work group (joystick) levers in all directions to check that the boom, arm, bucket (or other attachment) and swing functions operate correctly. Also, check that the travel controls operate properly.

NOTE: *Hydraulic system must be warmed up to operating temperatures.*

4. Raise the boom and arm so the bucket (or other attachment) is about 1 m (3 ft.) off the ground.
5. Move the safety lever down into "LOCK" position to deactivate the work group and travel functions. Move the work group (joystick) levers. There must be no movement

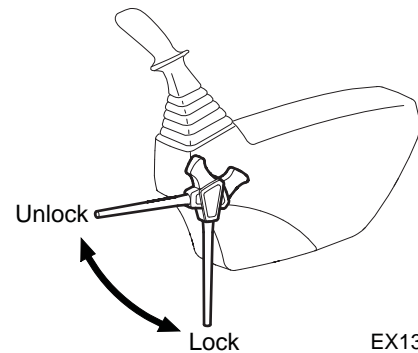

Figure 37

EX1300566

of the boom, arm, and attachment or swing functions when the controls are moved.

6. With the safety lever still in the "LOCK" position, move the travel controls. There must be no movement of the excavator tracks.
7. Move safety lever up into "UNLOCK" position. Raise the boom so the bucket (or other attachment) is about 3 m (10 ft.) off the ground. Operate the work group (joystick) lever to lower the boom slowly. While boom is lowering, move the safety lever down into "LOCK" position. Boom movement must stop. Repeat these steps for arm, bucket (attachment), swing and travel functions.
8. Lower work group to the ground and stop engine.

NOTE: *If the PILOT CUTOFF SWITCH (safety lever) does not deactivate the work group and travel functions as described above or if any parts are damaged, bent or missing, contact your DOOSAN distributor immediately for service. DO NOT MODIFY THE SYSTEM.*

Check Operation of All Exterior Lights, Horn and Control Console Indicator and Monitor Lights

1. Turn engine starter switch to "ON" position and observe all of the indicator lights.
2. Restore operation of any light bulbs that do not turn "ON" at this time.
3. Sound the horn. Repair or replace if required.
4. Turn "ON" and inspect all exterior work lights. Replace any monitors, burned out bulbs or cracked or broken housings or lenses.

**Start Engine, Check Starting Ability, and
Observe Exhaust Color at Start-up and
at Normal Operating Temperature.
Listen for Any Abnormal Sounds**

Check Operation of All Controls

IMPORTANT

Cold weather operation requires that the operator fully warm up the hydraulic oil before beginning machine operation. Follow all warm up instructions listed in the Operating Instruction section of this manual. Make sure to cycle oil through all of the components, including all cylinders, both travel motors and the swing motor. Cold hydraulic oil in the lines and components needs to be warmed before beginning full operation. If this is not done, damage to the cylinders or hydraulic motors can occur.

1. With the engine at rated speed, operate all of the controls.
2. Follow cold weather hydraulic system warm-up procedures.
3. Note any slow operations or unusual movements. Determine the cause and repair the fault before operating.

50 HOUR / WEEKLY SERVICE

Perform All Daily Service Checks

Grease Arm and Front Attachment Pins

Grease every 10 hours for first 100 hours and every 50 hours thereafter.

NOTE: *If the unit has been running or working in water the front attachment must be greased on a 10 hour/daily basis.*

- Position machine as shown below and lower the front attachment to the ground and stop engine.
- Press the grease fitting and inject grease with the grease gun on the marked point
- After injection, clean off the old grease that has been purged.

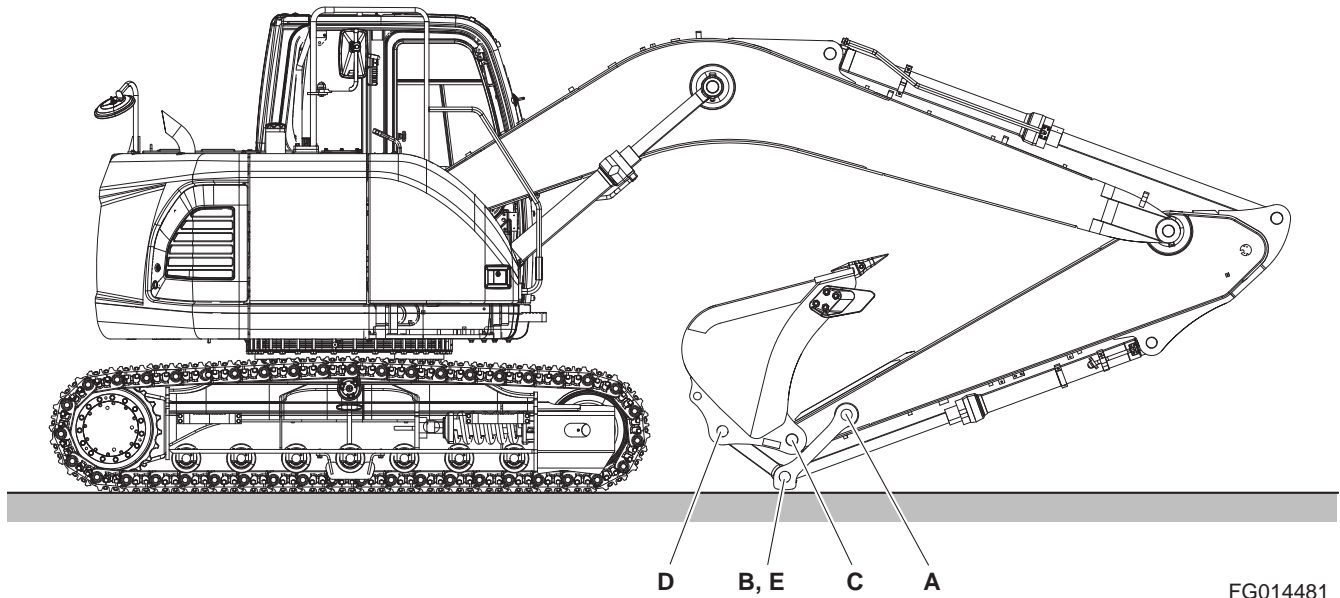

FG014481

Figure 38

| Reference Number | Description |
|------------------|--------------------------------|
| A | Arm Link Joint Pin (1 Point) |
| B | Link Joint Pin (2 Points) |
| C | Arm Bucket Joint Pin (1 Point) |

| Reference Number | Description |
|------------------|-----------------------------------|
| D | Bucket Link Joint Pin (1 Point) |
| E | Bucket Cylinder Rod Pin (1 Point) |

- A. Arm link joint pin (1 point)
- B. Link joint pin (2 points)
- C. Arm bucket joint pin (1 point)
- D. Bucket link joint pin (1 point)

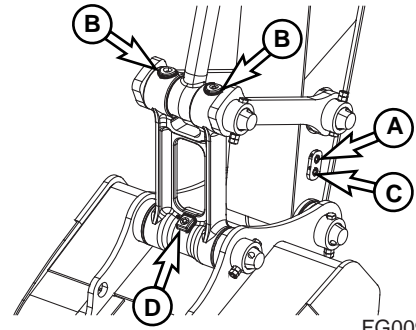

FG009561

Figure 39

- E. Bucket cylinder rod pin (1 point)

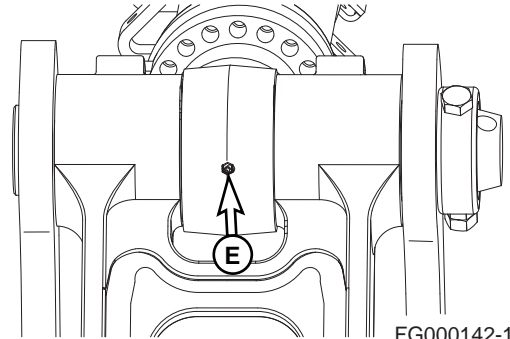

FG000142-1

Figure 40

Grease Swing Bearing

1. Park machine on firm and level ground. Lower the front attachment to the ground and stop engine.
2. There are three grease fittings for the swing bearing. Do not over lubricate. Purge old grease with new. Remove all purged grease.

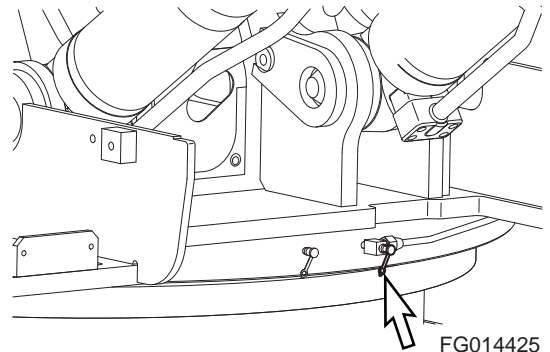

FG014425

Figure 41

Grease Dozer Blade Pin (Optional)

NOTE: Grease it per 10 hours during initial period of 100 hours after buying your new machine, after which period grease it per 50 hours.

NOTE: In case of performing work underwater, grease it per 10 hours irrespective of elapsed period.

1. Lower dozer blade to the ground.
2. Inject grease at total 6 points by 3 points per dozer cylinder by means of using grease gun.
3. Neatly remove old grease that has leaked out after greasing.

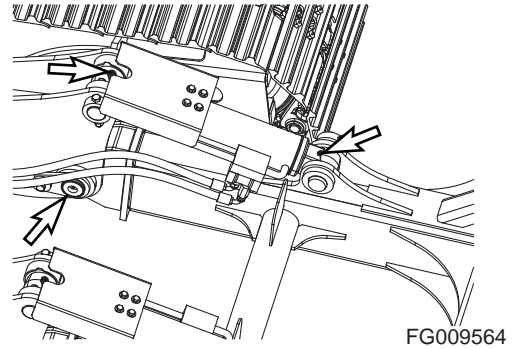

Figure 42

Drain Water and Sediment from Fuel Tank

1. Perform this procedure before operating the machine.
2. Drain water and sediment from bottom of fuel tank into a suitable container.

NOTE: Dispose of drained fluid according to local regulations.

NOTE: Always completely fill fuel tank at end of each workday to prevent condensation from forming on the inside walls of the tank.

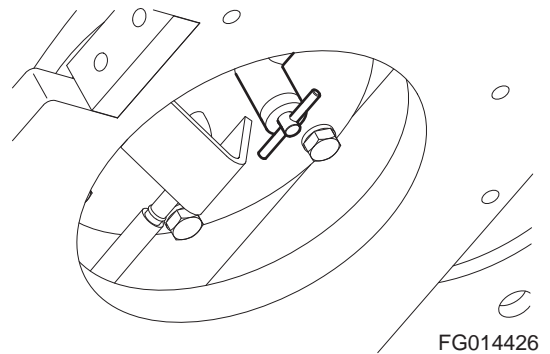

Figure 43

Check Engine Fan Belt for Cracks, Wear and Correct Tension (After First 50 Hours)

1. Inspect after first 50 hours of operation and every 250 hours thereafter. For details, See "Check Engine Fan Belt Tension" on page 4-33.

Inspect Track Assemblies for Proper Tension and Loose, Worn or Damaged Parts (Links, Shoes, Rollers, Idlers)

1. Do a daily walk-around inspection of all components including the track assemblies. Look for missing, damaged or excessively worn parts. See "Track Tension" on page 4-79.
2. Jack up each track and perform the two speed travel motor test.

250 HOUR / MONTHLY SERVICE

Perform All Daily and 50 Hour Service Checks

Grease Arm and Front Attachment Pins

Grease every 10 hours for first 100 hours and every 250 hours thereafter.

NOTE: *If the unit has been running or working in water the front attachment must be greased on a 10 hour/daily basis.*

- Position machine as shown below and lower the front attachment to the ground and stop engine.
- Press the grease fitting and inject grease with the grease gun on the marked point
- After injection, clean off the old grease that has been purged.

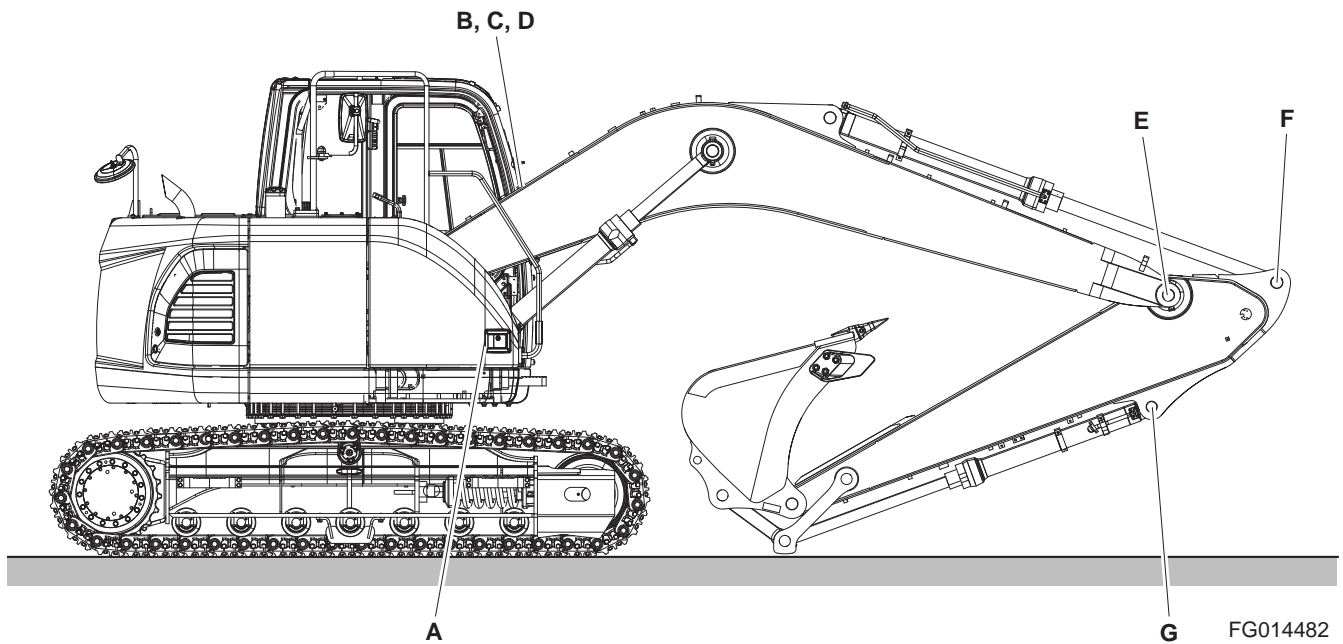

Figure 44

| Reference Number | Description |
|------------------|-----------------------------------|
| A | Boom Cylinder Head Pin (2 Points) |
| B | Boom Foot Pin (2 Points) |
| C | Boom Cylinder Rod Pin (2 Points) |
| D | Arm Cylinder Head Pin (1 Point) |

| Reference Number | Description |
|------------------|------------------------------------|
| E | Boom Arm Joint Pin (2 Points) |
| F | Arm Cylinder Rod Pin (1 Point) |
| G | Bucket Cylinder Head Pin (1 Point) |

A. Boom cylinder head pin (2 points)

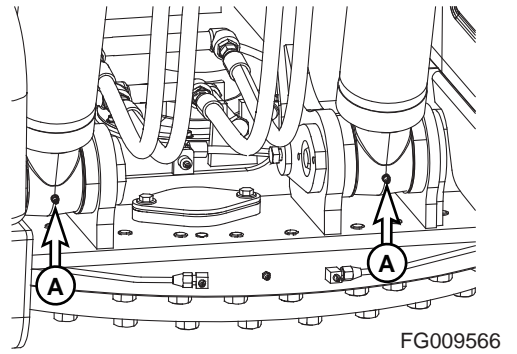

Figure 45

- B. Boom foot pin (2 points)
- C. Boom cylinder rod pin (2 points)
- D. Arm cylinder head pin (1 point)

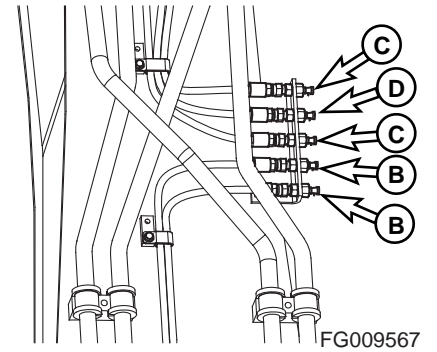

Figure 46

- E. Boom arm joint pin (2 points)
- F. Arm cylinder rod pin (1 point)

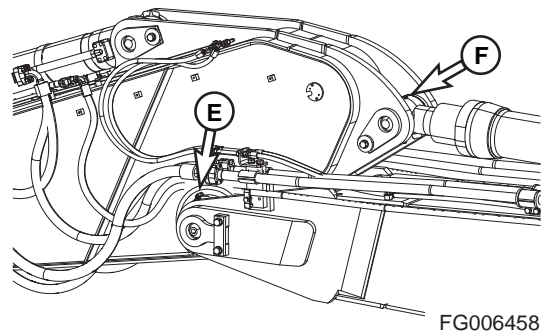

Figure 47

G. Bucket cylinder head pin (1 point)

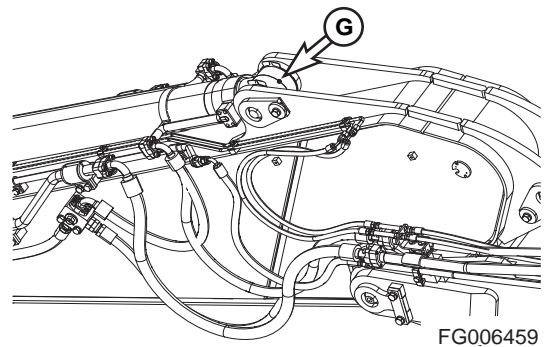

Figure 48

Check Engine Fan Belt Tension

IMPORTANT

A loose fan belt can cause engine overheating, poor charging, and/or premature belt wear. A belt that is too tight can cause damage to the water pump, alternator bearing or belt.

1. Inspect every 250 hours. (Inspect after first 50 hours of operation.)
2. With the engine shut off, check the tension of the fan belt by pressing downwards on the belt, midway between the fan pulley and alternator pulley. The belt should flex approximately 10 mm (0.4 in). See Figure 49. To adjust the belt, loosen the alternator adjustment plate bolts, adjust the belt tension and retighten the bolts.

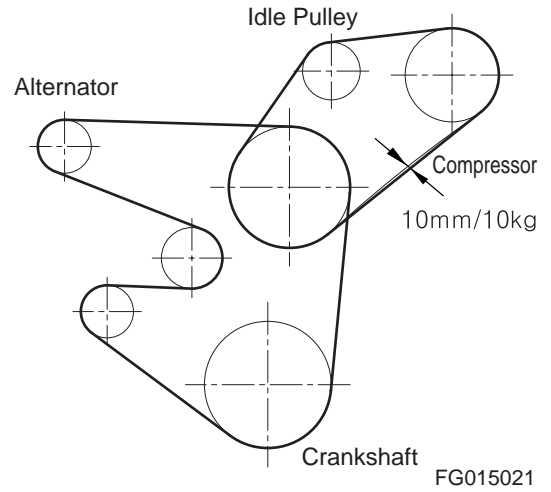

Figure 49

Check Engine Fan Belt Wear



WARNING

AVOID DEATH OR SERIOUS INJURY

Keep clear of engine fan and fan drive belts when the engine is running. Rotating fan and belt contact can cause injury.



WARNING

AVOID DEATH OR SERIOUS INJURY

When checking, adjusting or replacing drive belts, care must be taken to prevent accidental cranking of the engine. Be sure the starter switch is in the "OFF" position and the controls are tagged.

1. Replace badly worn, greasy or severely cracked belts immediately. These conditions prevent proper belt function. Visually inspect the belt. Check the belt for intersecting cracks. Transverse (across the belt width) cracks are acceptable. Longitudinal (direction of belt length) cracks that intersect with transverse cracks are not acceptable. Replace the belt if it is frayed or has pieces of material missing.
2. Before installing new belts, make sure all pulley grooves are clean and not worn. Replace pulley, if damaged, or if the grooves are worn.
3. All pulley support bearings, shafts, and brackets must be in working order.
4. When replacing belts and pulleys, pulley alignment must be checked with belts tensioned and brackets securely clamped. A misalignment that can be detected by the eye is detrimental to belt performance.
5. Do not force the belts into the pulley grooves by prying with a screwdriver or pry bar. This will damage the belt side cords which will cause the belts to turn and result in complete destruction of the belts in operation.
6. Belts on new machines and replacement belts lose their tension as they seat into the pulley grooves. Check the tension of new belts at 50 hour intervals until tension is stabilized and thereafter, every 250 hours. If the tension falls below the required minimum, the belt slips damaging the belts and pulley grooves.

NOTE: *When operating in abrasive conditions, check tension every 100 hours.*

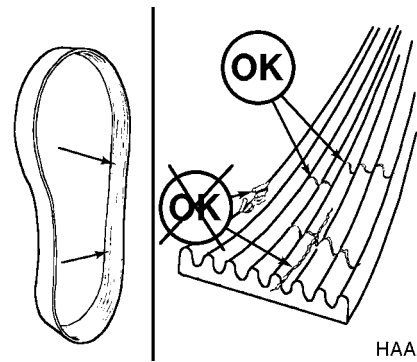

Figure 50

HAAA4030

Change Breaker Filter (Optional)



WARNING

AVOID DEATH OR SERIOUS INJURY

The hydraulic oil will be hot after normal machine operation.

Allow the system to cool down before changing pilot filter.

1. Park machine on firm and level ground. Lower the front attachment to the ground and stop engine.
2. Loosen the hydraulic oil tank breather cap to release pressure.
3. Locate breaker filter assembly (Figure 51).
4. Position a container under the filter assembly. Remove drain plug and completely drain the assembly.
5. Using a 30 mm spanner, unscrew filter housing from filter bottom.
6. Remove O-ring from filter head.
7. Replace filter.
8. Apply a small amount of oil around the entire O-ring and install the filter housing on the filter head.

NOTE: *Tightening torque: 27 kg•m (265 Nm, 195 ft lb)*

9. Install drain plug in bottom of filter housing.
10. After changing breaker filter, vent air from pump and check level of hydraulic oil tank.

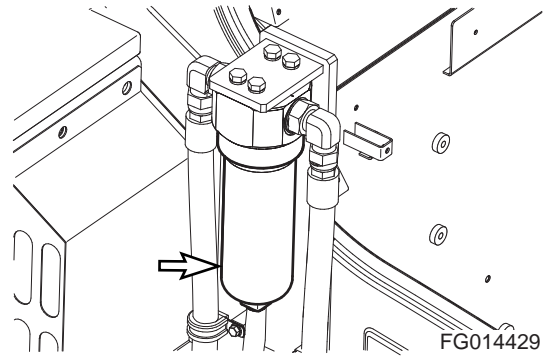

Figure 51

Replace Hydraulic Oil Return Filter (After First 250 Hours)

NOTE: *Replace hydraulic oil return filter after first 250 hours of operation or rebuild, then every 1,000 hours thereafter (See page 4-48).*

Change Pilot Filter (After First 250 Hours)

NOTE: *Change pilot filter after first 250 hours and every 1,000 hours thereafter (See page 4-49).*

Inspect Pins and Bushings of Front End Attachments for Signs of Wear

Check Fluid Levels in Batteries

See "Inspection of Battery Electrolyte Level" on page 4-69 for further information.

Inspect for Any Loose or Missing Nuts and Bolts

Inspect Fuel System Hose Clamps

500 HOUR / 3 MONTH SERVICE

Perform All Daily, 50 and 250 Hour Service Checks

Grease Swing Gear and Pinion



AVOID DEATH OR SERIOUS INJURY

Greasing swing gear and pinion must be serviced by only one person.

1. Remove inspection cover and inspect the condition of the grease. Make sure that water or other contaminants are not noticeable.

NOTE: *The upper structure must be rotated a little at a time so the entire face of the swing gear can be lubricated. Use extreme caution when performing this operation.*

2. If water or other contaminations are found, remove lower access cover so the gear teeth can be thoroughly cleaned and lubricated.
3. Install access covers after lubricating gear teeth.

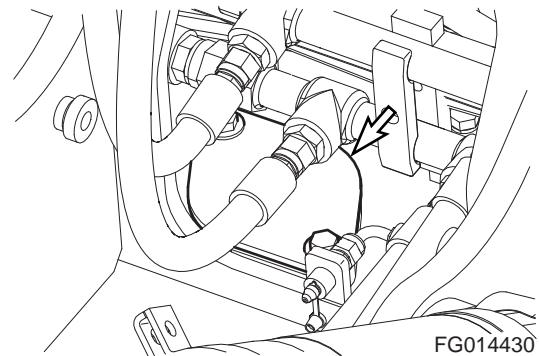

Figure 52

FG014430

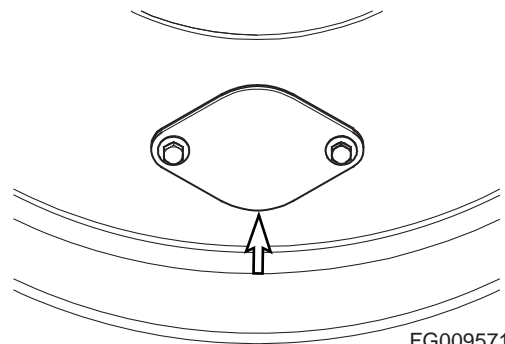

Figure 53

FG009571

Change Engine Oil and Filter

NOTE: Change engine oil and filter after 500 hours of operation or rebuild.



AVOID DEATH OR SERIOUS INJURY

DO NOT change oil on a hot engine. Allow the engine to cool down before attempting to change the engine oil and filter to avoid burns by touching hot engine parts.

1. Position a larger container under the engine. Remove cap (1, Figure 54) and install hose (2) to drain the engine oil. Remove hose (2) and install cap (1).

NOTE: Dispose of drained fluids in compliance with all applicable environmental laws and regulations.

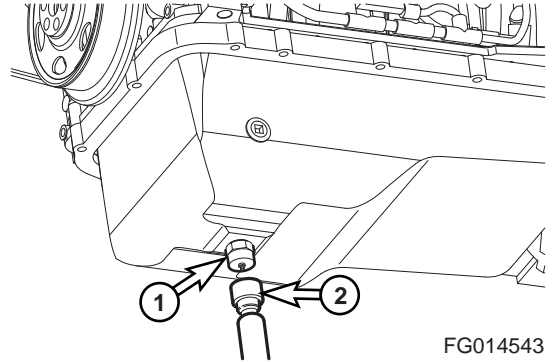

Figure 54

FG014543

2. Replace engine oil filter by using filter wrench. The engine oil filter is a spin-on type. See Figure 55. Remove and discard filter.
3. Install new filter. Apply a small amount of oil around filter gasket. Screw filter on head until gasket contacts head, turn filter 1/2 turn more.

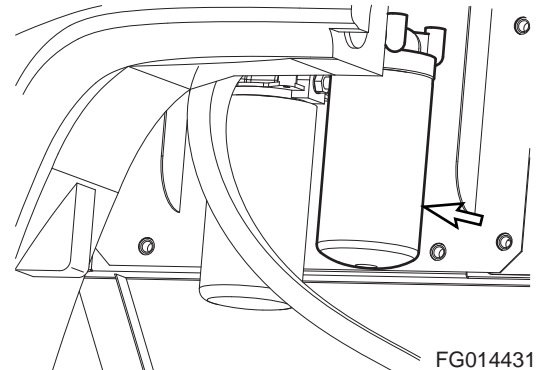

Figure 55

FG014431

4. Refill the engine with the correct oil through the oil fill port (Figure 56). Refer to the Lubrication Table of this manual for the recommended oil for the operating conditions.

NOTE: See "Fluid Capacities" on page 4-9 for capacity.

5. Start engine. Run engine for five minutes at "LOW IDLE", and check engine oil pressure light.
6. Stop engine. Look for signs of leaks at filter. Recheck oil level after fifteen minutes.

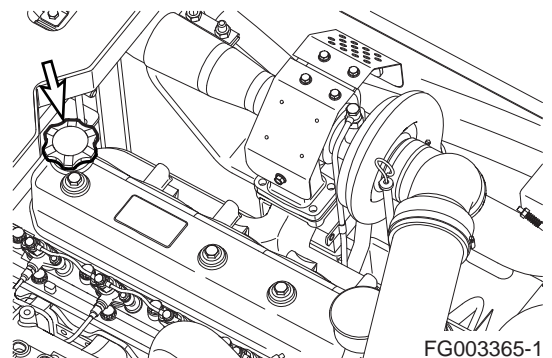

Figure 56

FG003365-1

Clean Air-Conditioning Outer Filter

The unit is equipped with an air filtration system which filters out dirt and dust particles from air being circulated into operator's cabin. This filter must be cleaned out.

NOTE: *In the unit is being operated in a dusty environment, the cleaning and replacement must be performed more frequently. If filter is damaged, replace damaged filter with a new one.*



WARNING

AVOID DEATH OR SERIOUS INJURY

All service and inspection of air-conditioning system must be performed with the starter switch in the "O" (OFF) position.



WARNING

AVOID DEATH OR SERIOUS INJURY

If using compressed air to clean the element, make sure that proper eye protection is worn.

NOTE: *All right and left call outs are based on the operator being seated in the operator's seat facing the front.*

1. The outer filter is located behind the operator's seat.

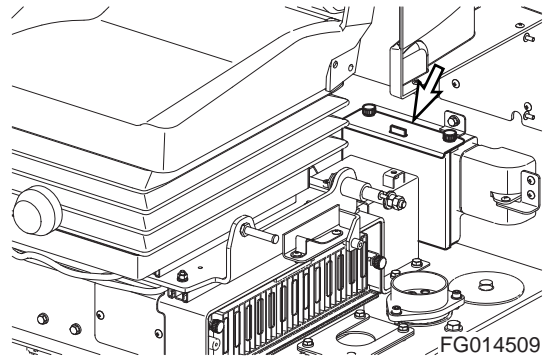

Figure 57

2. Open the cover by the removing knobs (Figure 58).

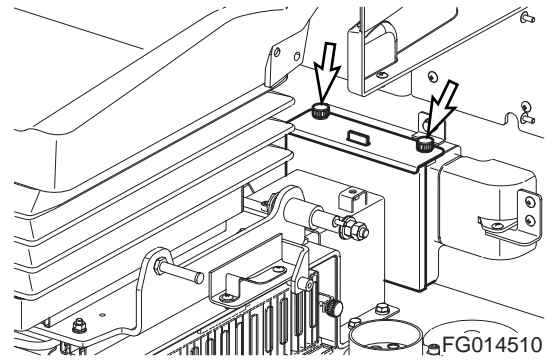

Figure 58

3. Remove filter (Figure 59) and inspect for any damage.
4. Use compressed air to clean filter. If filter is still dirty, then change to new one.
5. Reassemble filter and cover in reverse order.

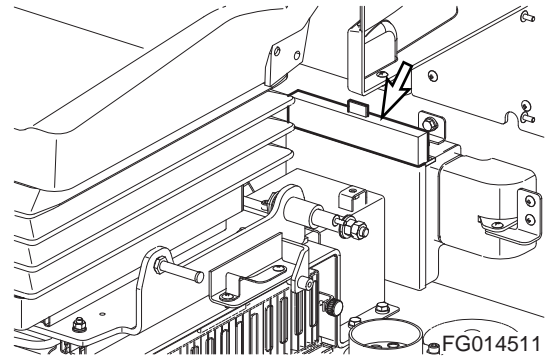

Figure 59

Check and Clean Air-Conditioning Inner Filter

 **WARNING**

AVOID DEATH OR SERIOUS INJURY

All service and inspection of air-conditioning system must be performed with the starter switch in the "O" (OFF) position.

 **WARNING**

AVOID DEATH OR SERIOUS INJURY

If using compressed air to clean the element, make sure that proper eye protection is worn.

1. Open the cover by removing knobs (1, Figure 60).
2. Remove screw (2, Figure 61) and filter (3, Figure 61) from the cover.

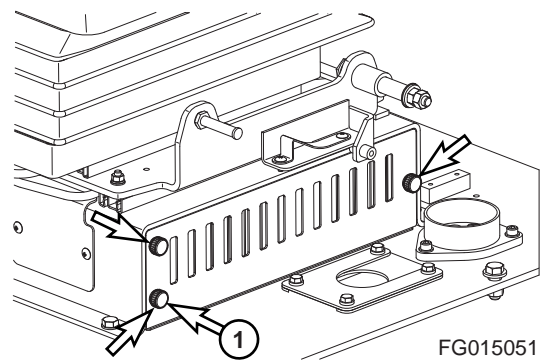
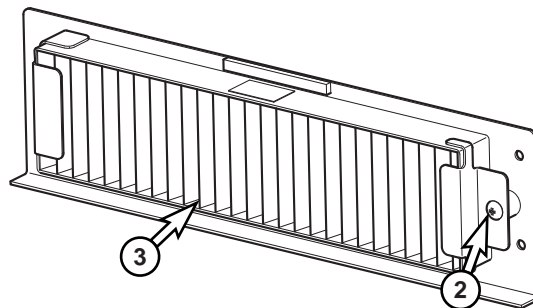

Figure 60

3. Use compressed air for cleaning filter.
If the filter is damaged, replace it by new one.
If the filter is very dirty use a mild soap or detergent and water to clean it.
4. Reassemble filter in reverse order.

IMPORTANT

If water was used to clean filter, be certain it is completely dry before installing.



FG015052

Figure 61

Clean Radiator, Oil Cooler, Intercooler, Fuel Cooler and Air Conditioner Condenser Core



AVOID DEATH OR SERIOUS INJURY

If compressed air, steam or water hit your body directly, there is danger of injury. Always wear protective glasses, mask and safety shoes during the cleaning process. Make sure that all extra personnel are clear of the work area.

1. Open the rear left door and engine cover.
2. Loosen the wing bolt(s) and remove dust net from in front of oil cooler and intercooler.
3. Clean the outside of the radiator and oil cooler, intercooler and fuel cooler with compressed air, steam or water. Wash from the outside of the engine compartment inwards. Repeat the cleaning process from the inside of the engine compartment outwards to remove all dirt and debris.

NOTE: Clean dust net and install it after cleaning radiator, oil cooler, intercooler and fuel cooler.

4. Clean air conditioner condenser core with compressed air, steam or water.

IMPORTANT

To prevent damage to the cores, apply compressed air from an appropriated distance. Damaged core can cause water leakage or overheating. In a dusty site, check the core daily, irrespective of the maintenance interval.

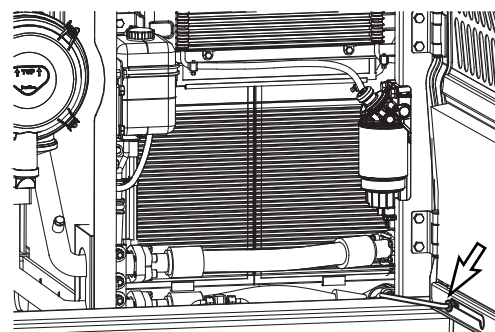

FG009572

Figure 62

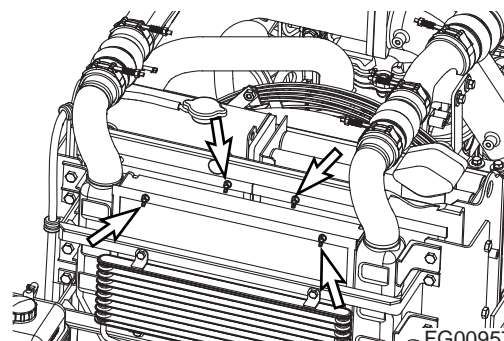

FG009573

Figure 63

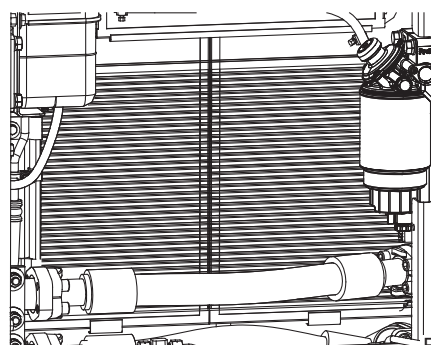

FG009574

Figure 64

Clean Outer Filter of Air Cleaner

NOTE: Clean outer filter every 500 hours/3 months of service.

NOTE: If air cleaner clogged warning light (Figure 65) on instrument panel comes "ON" the air cleaner must be serviced.

NOTE: When working in severely dusty conditions, the service interval must be shortened.



WARNING

AVOID DEATH OR SERIOUS INJURY

Never clean or attempt to remove the air cleaner filter if the engine is running.

If using compressed air to clean the filter, make sure that proper eye protection is worn.

1. Locate the air cleaner assembly.

NOTE: When it reaches every 500 hours or If indicator light (Figure 65) on instrument panel comes "ON" the air cleaner must be serviced.

NOTE: Replace outer filter after cleaning 5 times or every 2,000 hours/1 year of service.

2. Remove and clean rubber evacuator valve (1, Figure 66) from bottom of air cleaner housing cover (2). Inspect seal lips for wear or damage. Replace valve if necessary.

NOTE: Install evacuator valve with lips parallel to the cover.

3. Remove the access cover (2, Figure 67) by loosening the latches (3).

4. Remove outer filter (4, Figure 67) from the housing. Do not remove inner filter (5).

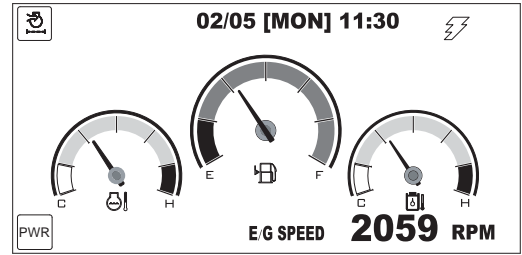

FG013734

Figure 65

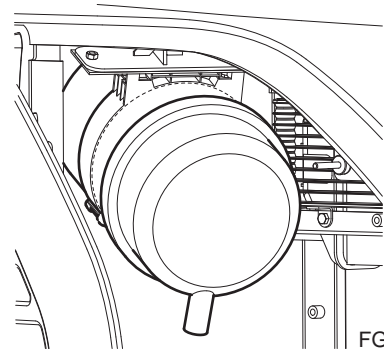

FG014432

Figure 66

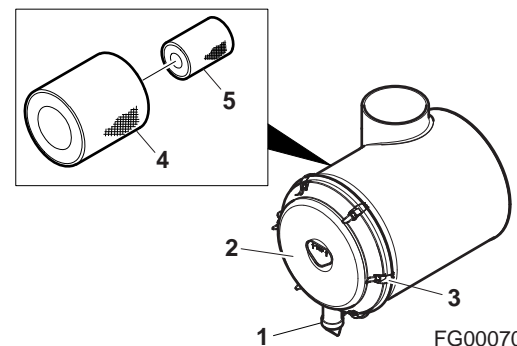

FG000702

Figure 67

- Clean the outer filter (4, Figure 67) by blowing compressed air from the inside of the filter towards the outside. Do not use more than 205 kPa (30 psi) air pressure.

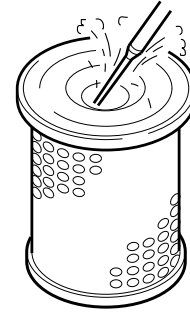

Figure 68

HAOC570L

- Check outer filter by shining a light through it. If small holes or thinner parts are found on the element after cleaning it, replace the filter.
- Clean the inside of the air cleaner body and the inside of the air cleaner cover. Do not use compressed air.
- Properly install the air filter and cover.
- After filter service be sure to install cover with arrows pointing "UP".

NOTE: *If after cleaning the outer filter, the air cleaner clogged indicator remains "ON", replace the outer and inner filters. Do not clean inner filter.*

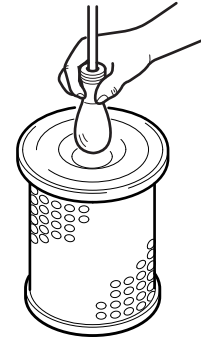

Figure 69

FG000412

Change of Water Separator & Pre Fuel Filter (Fuel Prefilter)

1. Open the right rear side door to access fuel prefilter.
2. Position a small container under prefilter. Drain fuel by opening drain valve on bottom of filter.

NOTE: *Dispose of drained fluids in compliance with all applicable environmental laws and regulations.*

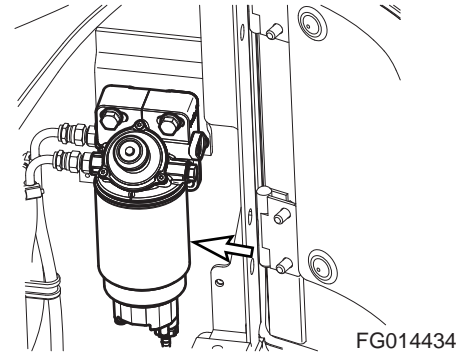

Figure 70

3. Remove bowl using supplied tool.
4. Remove cartridge.

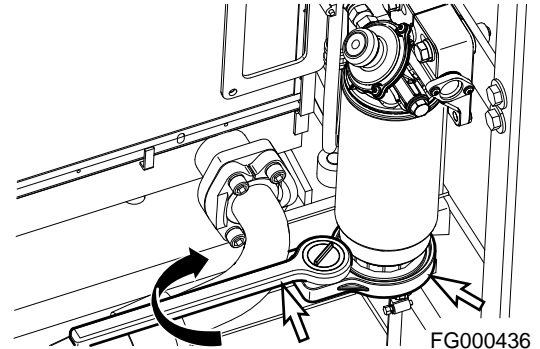

Figure 71

5. Coat surface of packing (2, Figure 72) with fuel on new cartridge (1).
6. Tighten the cartridge by hand until the packing comes into contact with the surface of the filter housing head.
7. When it reach the surface, tighten the cartridge about 3/4 of a turn more.
8. Coat surface of seal (3, Figure 72) with fuel, and tighten the bowl with tool.

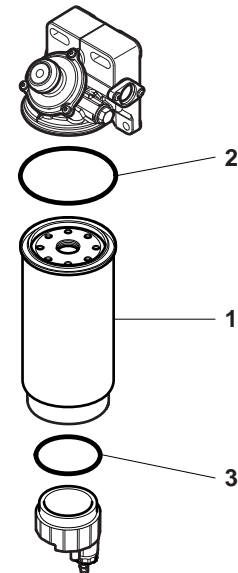

Figure 72

Change Main Fuel Filter



WARNING

AVOID DEATH OR SERIOUS INJURY

Exchange filter after waiting for engine to cool. Be careful of fire hazards. Do not smoke.

1. Access fuel filter through right side door.
2. Position a small container under fuel filter.
3. Unscrew fuel filter from head assembly. Discard fuel filter.

NOTE: *Dispose of drained fluids in compliance with all applicable environmental laws and regulations.*

4. After cleaning filter head, install new fuel filter. Screw filter on head until gasket contacts head, and turn filter 1/2 turn more with a filter wrench.

NOTE: *Coat fuel filter gasket with fuel.*

NOTE: *Fill fuel filter with clean fuel. This will help reduce fuel system priming.*

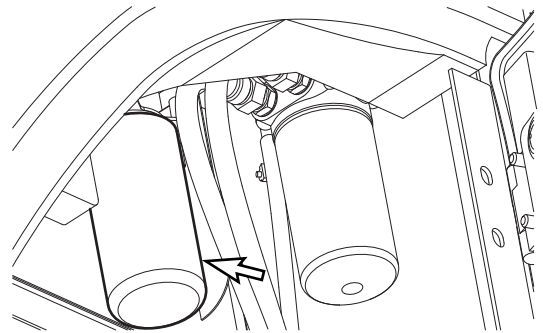

FG014435

Figure 73

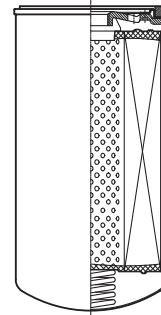

FG000478

Figure 74

Fuel System Priming

If air remains in the fuel inlet line to the engine, it can cause the engine to run in an abnormal condition. Air may impact the starting capability of the engine, and may also result in surging engine speeds.

If the machine happens to have run out of fuel, or if the fuel filter has been replaced, air may need to be bled using the following procedure:

1. Stop engine.
2. Loosen plug (1, Figure 75) on the fuel prefilter head.
3. Pump the hand operated primer pump (2, Figure 75) on the fuel prefilter. Pump primer until fuel is present at plug hole in fuel prefilter head.
4. Tighten plug (1, Figure 75) in fuel prefilter head.
5. Continue to pump primer pump until a strong resistance is felt.
6. Start engine and look for signs of leaks.
7. Repeat procedure if necessary.

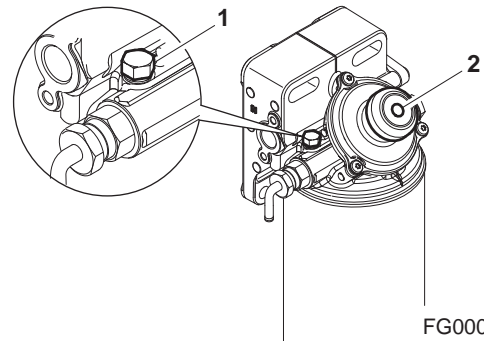

FG000431

Figure 75

Check Oil Level in Travel Reduction Device (One on Each Side of Unit)



WARNING

AVOID DEATH OR SERIOUS INJURY

The gear oil is very hot after the machine has been operating. Shut all systems down and allow them to cool.

Before removing the motor case, loosen the plug slightly to allow pressurized air to escape. Residual pressure in the travel reduction device can cause the plug to be dislodged and oil to squirt out suddenly.

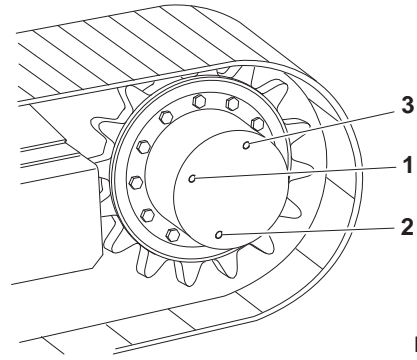

Figure 76

FG028800

| Reference Number | Description |
|------------------|----------------|
| 1 | Oil Level Plug |
| 2 | Drain Plug |
| 3 | Fill Plug |

1. Make sure that the machine is on firm and level ground.
2. Rotate the track until ports (1 thru 3, Figure 76) are in their proper positions as shown.
3. Loosen fill plug (3, Figure 76) slightly to allow pressurized air to escape.
4. Remove oil level plug (1, Figure 76).
5. Check oil level. The oil must be near the bottom of the level plug opening.
6. Add oil through the fill plug (3, Figure 76) opening, if necessary.
7. Clean and install oil level and fill plugs (1 and 3, Figure 76).
8. Repeat this procedure on the other travel reduction device.

Change Oil in Travel Reduction Device (One on Each Side of Unit) (After First 500 Hours)

NOTE: Drain and refill oil after first 500 hours of operation or rebuild, and every 1,000 hours thereafter (See page 4-50).

Change Swing Reduction Device Oil (Drain and Refill After First 500 Hours)

NOTE: Change swing reduction device oil after first 500 hours on a new machine and every 1,000 hours thereafter (See page 4-51).

1,000 HOUR / 6 MONTH SERVICE

Perform All Daily, 50, 250 and 500 Hour Service Checks

Grease Swing Reduction Device

1. Park machine on firm and level ground. Lower the front attachment to the ground and stop engine.
2. Remove air vent plug (1, Figure 77) from swing reduction device.

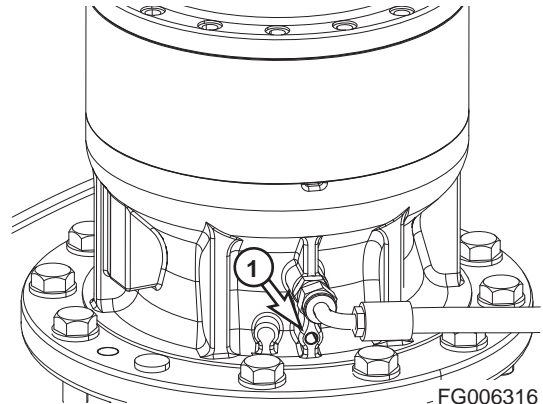

Figure 77

3. Press grease fitting and inject grease with the grease gun on the marked point (2, Figure 78).
4. Install air vent plug (1, Figure 77) in swing reduction device.

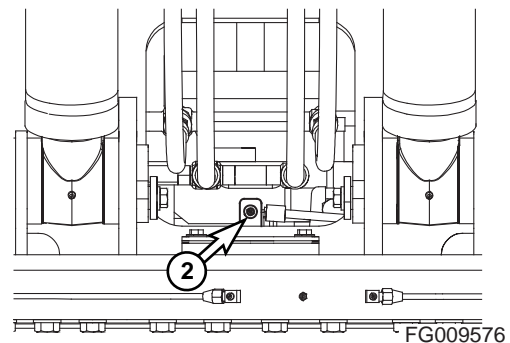

Figure 78

Change Air Breather Filter

1. Park machine on firm and level ground. Lower the front attachment to the ground and stop engine.
2. Lift the breather cap (2, Figure 79) slightly to release the internal pressure.
3. Unscrew the bolt (1, Figure 79) and take off the breather cap (2, Figure 79).
4. Change a filter cartridge (3, Figure 79) and assemble the breather cap by tightening the bolt.

NOTE: Used filter should always be disposed of according to local regulations.

NOTE: When the machine is operated under dusty work sites, the air breather filter needs to be cleaned or replaced on a regular basis even before the expected replacement date.

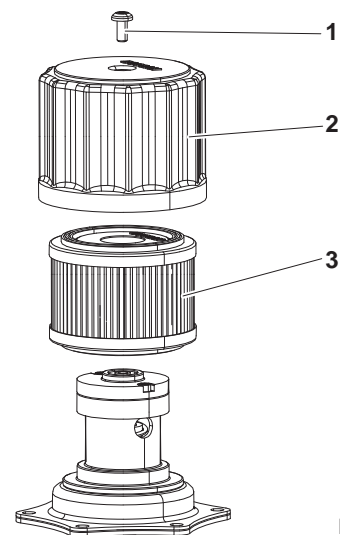
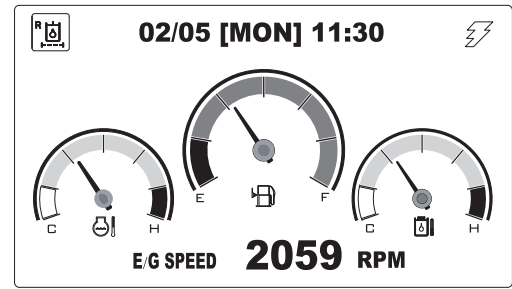

Figure 79

Replace Hydraulic Oil Return Filter

NOTE: Change hydraulic oil return filter after first 250 hours of operation or rebuild, and every 1,000 hours thereafter.

NOTE: If return filter clogged warning light (Figure 80) on instrument panel comes "ON" the return filter must be serviced.



FG013832

Figure 80

WARNING

AVOID DEATH OR SERIOUS INJURY

The hydraulic oil will be hot after normal machine operation. Allow the system to cool before attempting to service any of the hydraulic components.

The hydraulic tank is pressurized. Loosen the hydraulic breather cap slightly to allow the pressurized air to vent. After the pressure has been released, it is safe to remove either the fill cap or service covers or drain water from the tank.

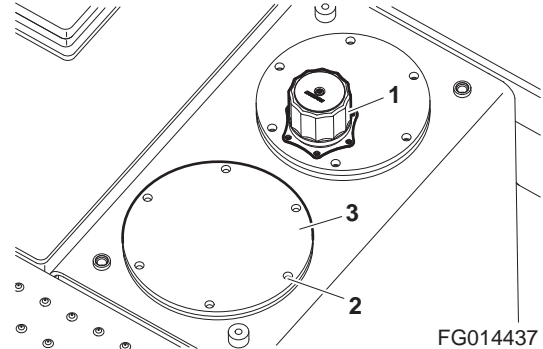

FG014437

Figure 81

IMPORTANT

Make sure to clean any dirt or water from the top of the hydraulic tank, especially around the fill port and filter ports.

1. Park machine on firm and level ground. Lower the front attachment to the ground and stop engine.
2. Lift the breather cap (1, Figure 81) slightly to release the internal pressure.
3. Remove bolts (2, Figure 81) and service cover (3). Remove spring (4), valve (5) O-ring (6), and bypass strainer (7), and then filter (8).

4. Remove filter and discard.

NOTE: Used filter should always be disposed of according to local regulations.

5. Install new filter and a new O-ring. Install bypass strainer, valve and spring. Install service cover plate.
6. Tighten the breather cap (1, Figure 81).
7. Run engine for ten minutes at low idle to purge air from circuit.
8. Check level in hydraulic oil tank (See page 4-17). Add oil if necessary.

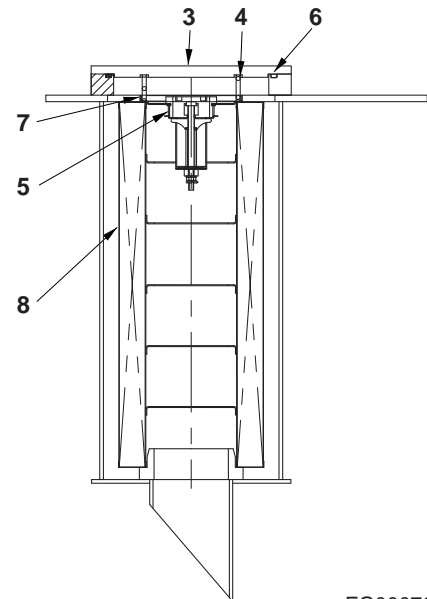

FG000761

Figure 82

Change Pilot Filter

NOTE: Change pilot filter after first 250 hours of operation or rebuild, and every 1,000 hours thereafter.

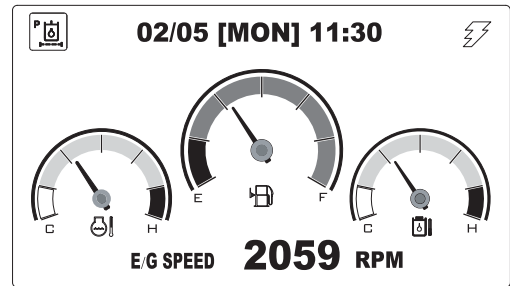

FG013895

Figure 83



WARNING

AVOID DEATH OR SERIOUS INJURY

The hydraulic oil will be hot after normal machine operation.

Allow the system to cool down before changing pilot filter.

1. Park machine on firm and level ground. Lower the front attachment to the ground and stop engine.
2. Lift the breather cap (1, Figure 81) slightly to release the internal pressure.
3. Locate pilot system filter assembly.
4. Unscrew canister (2, Figure 84) and remove O-ring (3) and filter cartridge (4).

NOTE: The canister will be filled with oil. Use caution when removing this assembly.

5. Insert a new filter cartridge and O-ring. Apply a small amount of oil around the entire O-ring and install the canister assembly onto the filter head (1, Figure 84).

NOTE: Used filter should always be disposed of according to local regulations.

6. After changing pilot filter, vent air from pump and check level of hydraulic oil tank.

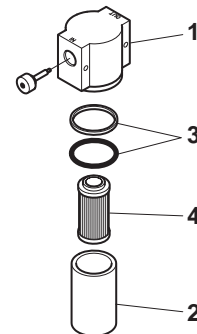

DS1703795

Figure 84

Change Oil in Travel Reduction Device (One on Each Side of Unit)



WARNING

AVOID DEATH OR SERIOUS INJURY

The gear oil is very hot after the machine has been operating. Shut all systems down and allow them to cool.

Before removing the motor case, loosen the plug slightly to allow pressurized air to escape. Residual pressure in the travel reduction device can cause the plug to be dislodged and oil to squirt out suddenly.

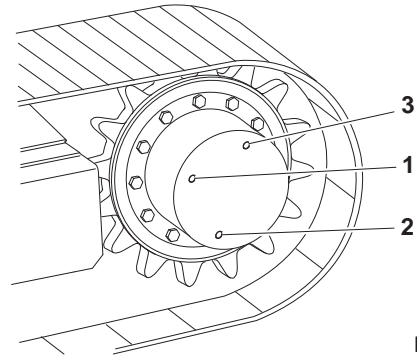

Figure 85

FG028689

| Reference Number | Description |
|------------------|----------------|
| 1 | Oil Level Plug |
| 2 | Drain Plug |
| 3 | Fill Plug |

NOTE: Drain oil after first 500 hours of operation or rebuild, and every 1,000 hours thereafter.

1. Make sure that the machine is on firm and level ground.
2. Rotate the track until ports (1 thru 3, Figure 85) are in their proper positions as shown.
3. Place a container under drain plug (2, Figure 85) and remove plugs (1 thru 3) to drain the travel reduction gear oil.

NOTE: Dispose of drained fluids in compliance with all applicable environmental laws and regulations.

4. Install drain plug (2, Figure 85). Refill the travel reduction gear case with fluid through fill port (3) until fluid level is at port (1). Install level plug (1) and fill plug (3).

NOTE: See "Fluid Capacities" on page 4-9 for capacity.

5. Repeat this procedure on the other travel reduction device.

Change Swing Reduction Device Oil

NOTE: Change swing reduction device oil after first 500 hours of operation or rebuild and every 1,000 hours thereafter.



WARNING

AVOID DEATH OR SERIOUS INJURY

The gear oil is very hot after the machine has been operating. Shut all systems down and allow them to cool.

1. Set a container under excavator.
2. Remove cap (3, Figure 87) and install hose (4) to drain the swing reduction device oil.

NOTE: Dispose of drained fluids in compliance with all applicable environmental laws and regulations.

3. After draining oil, remove hose and install cap.

4. Remove breather/fill cap (2, Figure 86) and add oil to "H" mark on dipstick (1).

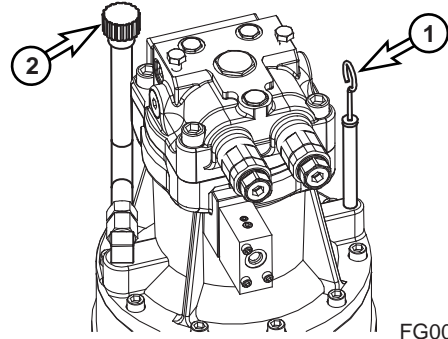

Figure 86

FG009555

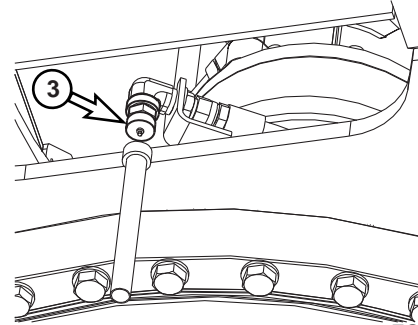

Figure 87

FG009556

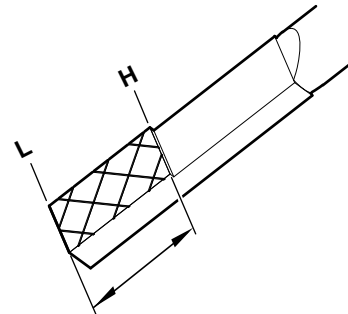

Figure 88

FG000419

Change Air-Conditioning Outer Filter

The unit is equipped with an air filtration system which filters out dirt and dust particles from air being circulated into operator's cabin. This filter must be cleaned out.

NOTE: *In the unit is being operated in a dusty environment, the cleaning and replacement must be performed more frequently. If filter is damaged, replace damaged filter with a new one.*



AVOID DEATH OR SERIOUS INJURY

All service and inspection of air-conditioning system must be performed with the starter switch in the "O" (OFF) position.

NOTE: *All right and left call outs are based on the operator being seated in the operator's seat facing the front.*

1. The outer filter is located behind the operator's seat.
2. Open the cover by the removing knobs (Figure 90).

3. Remove filter (Figure 91) and replace with new one.
4. Reassemble in reverse order.

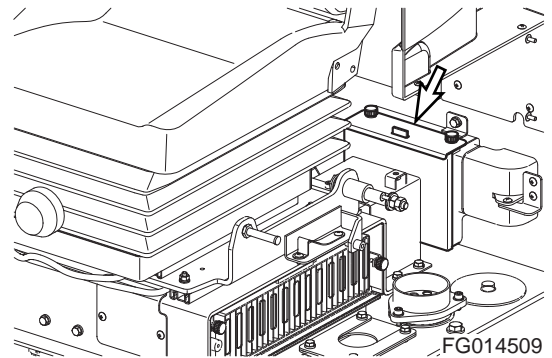

Figure 89

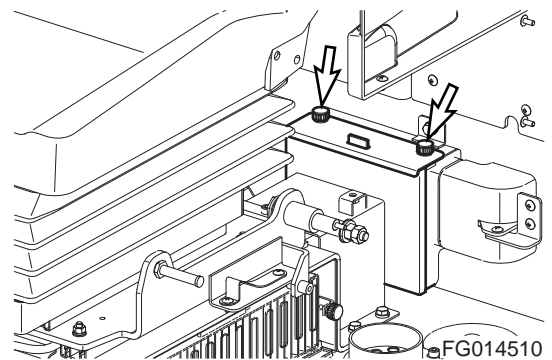

Figure 90

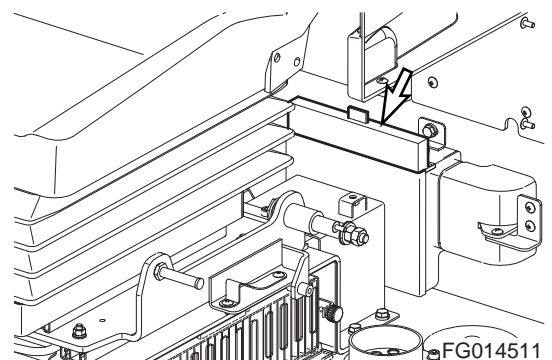

Figure 91

Change Air-Conditioning Inner Filter

WARNING

AVOID DEATH OR SERIOUS INJURY

All service and inspection of air-conditioning system must be performed with the starter switch in the "O" (OFF) position.

1. Open the cover by removing knobs (1, Figure 60).
2. Remove screw (2, Figure 61) and filter (3, Figure 61) from the cover.
3. Replace it by new one.
4. Reassemble filter in reverse order.

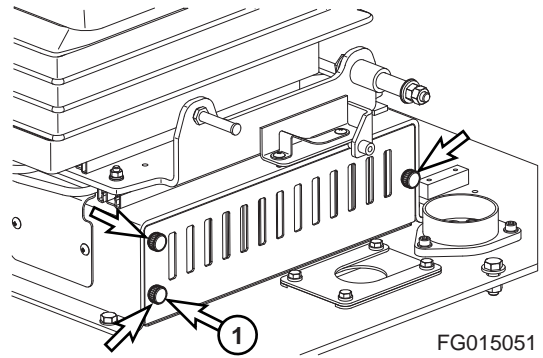

Figure 92

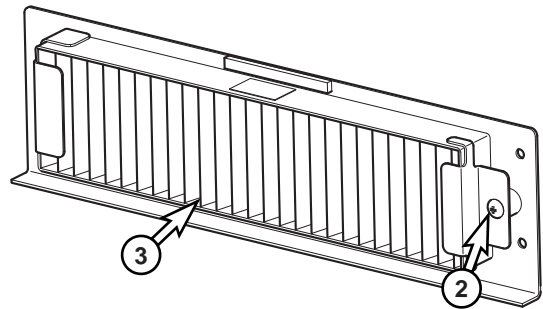

Figure 93

Check Air Conditioner Refrigerant



WARNING

AVOID DEATH OR SERIOUS INJURY

Mixing of tobacco smoke and freon is deadly.

Do not smoke while servicing or recharging air-conditioning system.

Contact with refrigerant can result personal injury, frost bite. Wear Protective glasses when refrigerant lines are opened.

System may still under pressure, release it slowly in a well ventilated area.

Inhaling air conditioner refrigerant gas through a lit cigarette or other smoking method or inhaling fumes released from a flame contacting air conditioner refrigerant gas, can cause bodily harm or death.

Use a certified recovery and recycling cart to properly remove the refrigerant from the air conditioning system.

1. Run engine at about 1,800 rpm. Operate for a minimum of ten minutes to stabilize the system.
2. Press the "HI" fan speed switch to set maximum air flow.
3. Put the temperature control switch in maximum cooling position.
4. Press the "Internal Air Circulation" switch.
5. Compare the flow of bubbles in the sight glass of receiver dryer with the drawings in the following table.

IMPORTANT

Overfilling refrigerant can cause dangerous high-pressure and poor cooling action; and low refrigerant level can cause compressor damage.

Always maintain refrigerant at normal level.

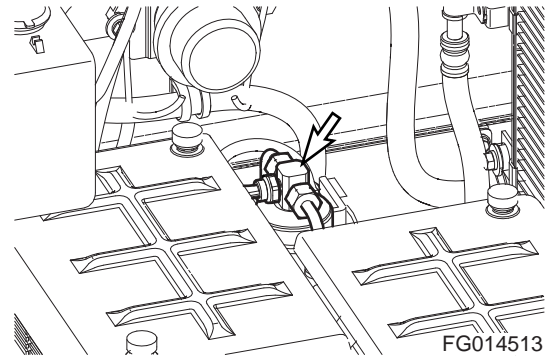
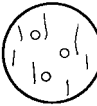
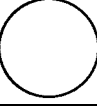
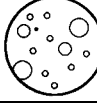

Figure 94

| Amount of Refrigerant | Appearance of the Sight Glass | Solutions |
|-----------------------|---|--|
| Normal |  <p>Almost clear. Any bubbles disappear.</p> | |
| High |  <p>No bubbles are seen.</p> | Charge or withdraw the system with the correct amount of HFC-134a refrigerant. |
| Low |  <p>A flow of bubbles is visible.</p> | |

Change Fuel Cap Filter



WARNING

AVOID DEATH OR SERIOUS INJURY

External shock or damages to fuel cap may lead to permanent damage to filter.

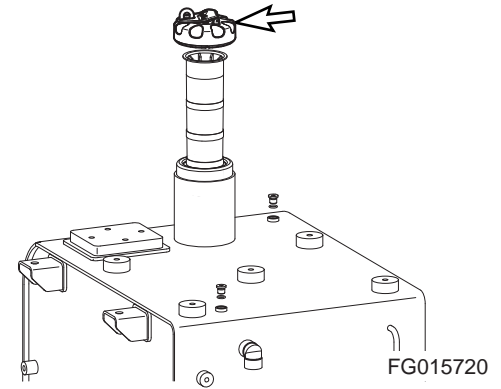

Figure 95

1. See under the fuel cap as shown on (Figure 96). Rotate bolt to CCW direction to loosen.

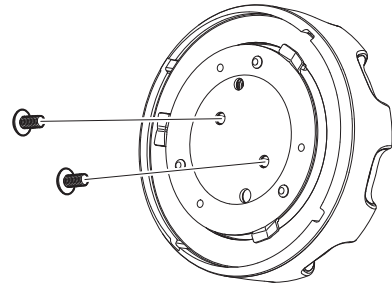

Figure 96

2. After disengaging it as shown on (Figure 97), carefully lay it on floor.

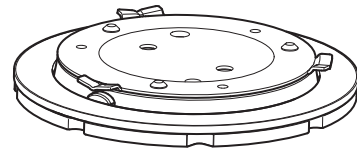

Figure 97

3. After disengaging, disengage rubber as shown on (Figure 98).

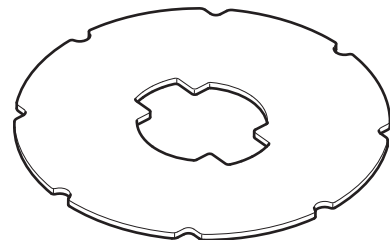
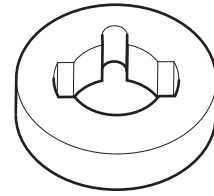

Figure 98

4. After disengaging as shown on (Figure 98), you may now exchange it to a new filter as shown on (Figure 99).



FG015687

Figure 99

5. After exchanging to a new filter, you may now assemble back in reverse order.

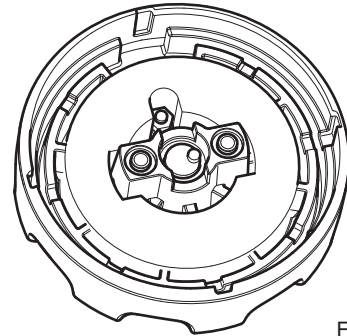

FG015688

Figure 100

Check and Adjust Engine **

Contact your nearest DOOSAN dealer.

Engine dealer for checking and adjusting the following items:

- Engine Compression Pressure.
- Injection Pressure.
- Injection Timing.

2,000 HOUR / YEARLY SERVICE

Perform All Daily, 50, 250, 500 and 1,000 Hour Service Checks

Replace Outer and Inner Air Cleaner Elements



WARNING

AVOID DEATH OR SERIOUS INJURY

Never clean or attempt to remove the air cleaner element if the engine is running.

NOTE: Replace outer element after cleaning 5 times or every 2,000 hours of service.

NOTE: Replace inner element whenever a new outer element is installed.

If there is clogged filter signal on the gauge panel, use the following procedure.

1. Open the access door at the rear of the cabin.
2. Remove the evacuator valve (1, Figure 102) and air cleaner cover (2).

NOTE: Inspect evacuator valve seal lips for wear or damage. Replace valve if necessary. Install evacuator valve with lips parallel to the cover.

3. Remove outer filter (4, Figure 102) from the air cleaner housing.
4. Clean the air cleaner cover and the inside of the air cleaner housing.
5. Remove inner filter (5, Figure 103).
6. Clean out inside of air cleaner housing. Do not use compressed air to blow out housing.
7. Install new inner filter. Do not clean and reuse inner element.
8. Install new outer filter.
9. Install air cleaner cover and evacuator valve.

NOTE: Make sure that all gaskets and cover are properly installed and seated.

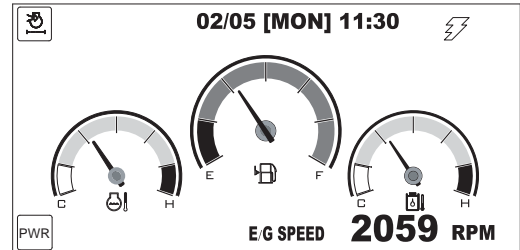

Figure 101

FG013734

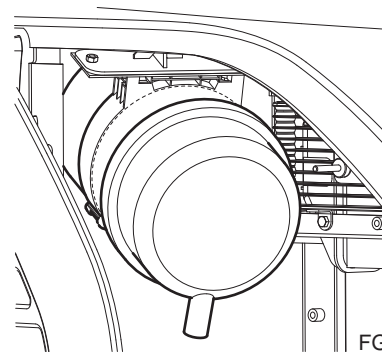

Figure 102

FG014432

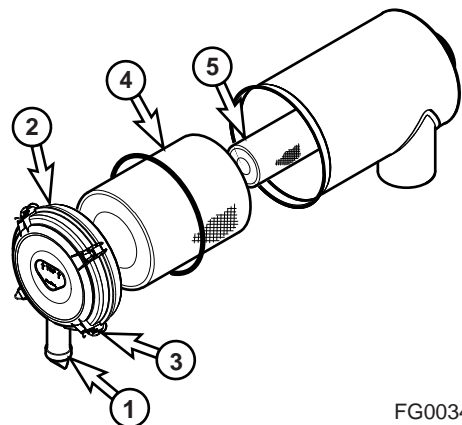

Figure 103

FG003466

Change Radiator Coolant

NOTE: Do not mix ethylene glycol and propylene glycol antifreeze together. See "Engine Cooling System" on page 4-72, for further details.



WARNING

AVOID DEATH OR SERIOUS INJURY

Allow the engine to cool before releasing the radiator cap. Make sure to loosen the cap slowly to release any remaining pressure.

Radiator cleaning is performed while the engine is running. Take extreme caution when working on or near a running engine. Make sure to lock out and tag the controls notifying personnel that service work is being performed.

Do not remove radiator cap unless it is required. Check the coolant level in the coolant recovery tank.

IMPORTANT

Do not mix up the antifreeze from different makers. Mixing the two compounds can cause generation of foreign material which can damage the system. Therefore, it is recommended to use authorized DOOSAN genuine antifreeze solution.

To achieve the best cooling performance, keep the mixing ratio of the antifreeze and water by 50 : 50. Using water only can corrode the coolant circuit.

In bitterly cold working conditions, the customer should frequently check the performance of the coolant for appropriateness for the weather and then determine change cycle of the coolant.

1. Slowly open the radiator cap to allow any pressure to escape.
2. Place a container under the radiator and open the drain valve (2, Figure 105).

NOTE: Dispose of drained fluids in compliance with all applicable environmental laws and regulations.



Figure 104

ARO1760L

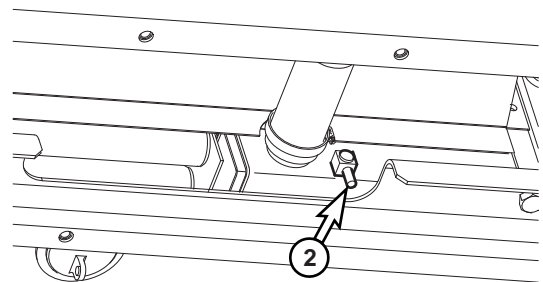

Figure 105

FG001407

3. Remove coolant drain plug (1, Figure 106) from engine.
4. Install drain plug, and close drain valve after coolant has completely drained from system.
5. Fill cooling system with a flushing solution.
6. Run engine at low idle until the coolant temperature gauge reaches the "BLUE ZONE". Run engine for another ten minutes.
7. Allow engine to cool.
8. Drain flushing fluid and fill system with water.
9. Run engine again to allow water to completely circulate.
10. After allowing engine to cool, drain water and fill system with proper antifreeze mixture for ambient temperature. Refer to coolant concentration table. See "Antifreeze Concentration Tables" on page 4-74.
11. Run engine without radiator cap installed, so that all air will be purged from system. Fill radiator to fill neck.
12. Drain and fill radiator coolant recovery tank.

NOTE: *When refill or replace coolant, select "heater-full hot" mode to fully open the water valve.*

Coolant will then flow into the heater's core to prevent air from being trapped in it.

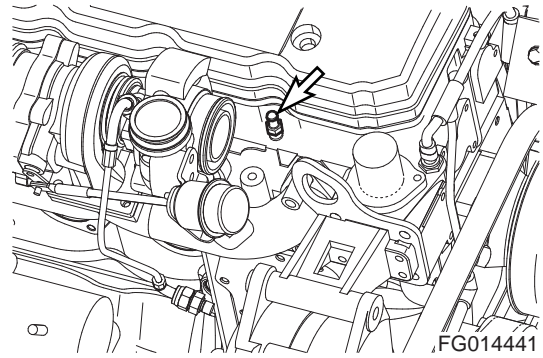
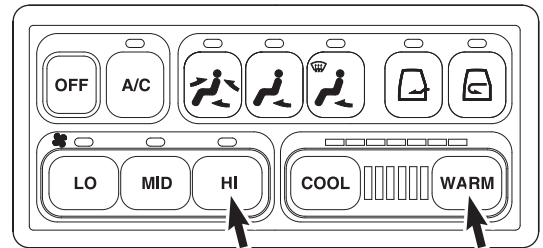

Figure 106



EX1502246

Figure 107

Hydraulic Oil Exchange and Suction Strainer Cleaning



WARNING

AVOID DEATH OR SERIOUS INJURY

The hydraulic oil will be hot after normal machine operation. Allow the system to cool before attempting to service any of the hydraulic components.

The hydraulic tank is pressurized. Loosen the breather cap to allow the pressurized air to vent. After the pressure has been released, it is safe to remove either the fill cap or service covers.

IMPORTANT

Make sure to clean any dirt or water from the top of the hydraulic tank, especially around the fill port and filter ports.

Hydraulic oil change interval is 2,000 hours, only when DOOSAN Genuine Oil is used. If another brand of oil is used, guaranteed change interval is 1,000 hours.

NOTE: *Based on the type of excavating being completed, the working conditions (extremely hot or dusty) and the extra front end attachments being used (hydraulic breaker, etc.), the hydraulic fluid will need to be changed more frequently.*

1. Park machine on firm and level ground. Swing upper structure parallel to tracks. Lower boom and position bucket on ground as shown in Figure 109.
2. Move safety lever to "LOCK" position.
3. Stop engine.
4. Release pressurized air from hydraulic tank by rotating breather cap (1, Figure 112).



Figure 108

ARO1760L

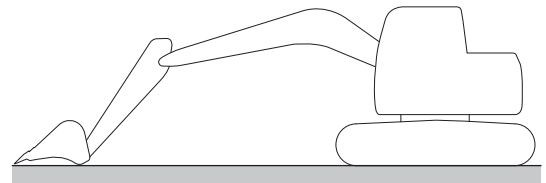

Figure 109

EX1300561

- Drain hydraulic oil from tank into a container capable of holding 147.8 liters (39 U.S. gal.). After draining tank, install drain plug.

IMPORTANT

Be careful of squirting oil when removing drain plug.

NOTE: *Used filter and used oil should always be disposed of according to local regulations.*

- Carefully remove bolts and cover (2, Figure 112) from top of hydraulic oil tank. There is a spring (3) under the cover that will force the cover up.
- Remove spring (3, Figure 112) and strainer (5), by pulling on rod (4).
- Clean inside and outside of strainer. Replace strainer if it is broken.
- Position strainer (5, Figure 112) on boss portion of suction pipe (6).

NOTE: *Measurement "A" is 735 mm (25.59 in).*

- Fill the hydraulic oil tank. Check level using sight gauge on side of tank.
- Place spring (3, Figure 112) on rod (4) and assemble cover (2).
- After replacing and cleaning the hydraulic oil, filter and strainer, vent the system. See "Venting and Priming Hydraulic System" on page 4-81.

IMPORTANT

When the hydraulic breaker is being used, because of the higher heat generated by this unit, use replacement intervals recommended under the "Hydraulic Oil and Filter Service Intervals" on page 3-37.

- Check level of hydraulic oil tank. (See page 4-17)

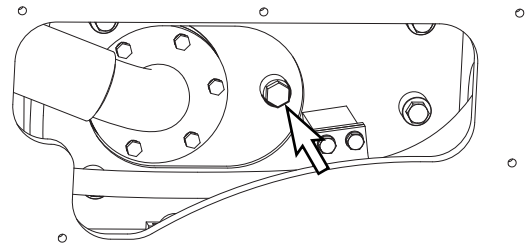

Figure 110

FG014419

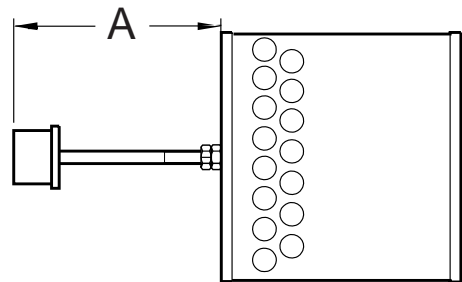

Figure 111

HAOC411L

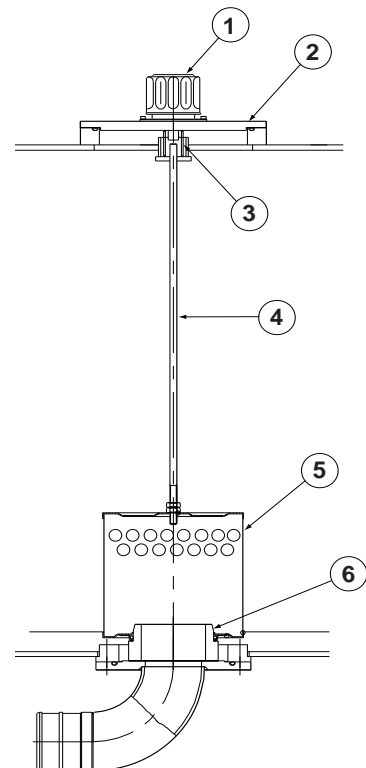

Figure 112

ARO1720L

Check Alternator and Starter**

**These checks need to be completed by an authorized DOOSAN dealer.

Check All Rubber Antivibration Shock Mounts

Perform and Record Results of Cycle Time Tests

Inspect Machine to Check for Cracked or Broken Welds or other Structural Damage

Check, Adjust Valve Clearance **

Check Head Bolt Torques

4,000 HOUR / BIENNIAL SERVICE

Major Parts - Periodic Replacement

To ensure safe operation and work, perform periodic inspections. Also, to increase safety, replace the following parts. These parts are the ones most often subjected to abrasion, heat and fatigue. Exchange these parts with new ones at the designated time intervals, even if the old parts look good.

Always replace all related parts such as gaskets and O-rings. Use only original equipment manufacturers parts.

| Major Component | | Parts Name to be Exchanged Periodically | Time to Exchange |
|------------------|-------------|---|------------------------|
| Engine | | Fuel hose (Tank to fuel prefilter) | 2 years or 4,000 hours |
| | | Fuel hose (Fuel prefilter to fuel cooler) | |
| | | Fuel hose (Fuel cooler to ECU) | |
| | | Fuel hose (Tank to CP pump) | |
| | | Heater hose (Heater to engine) | |
| | | Heater hose (Heater to radiator) | |
| | | Air Conditioner hose | |
| Hydraulic System | Body | Pump suction hose | 2 years or 4,000 hours |
| | | Pump discharge hoses | |
| | | Pump side branch hoses | |
| | | Swing motor hoses | |
| | | Travel motor hoses | |
| | Work Device | Boom cylinder line hoses | |
| | | Arm cylinder line hoses | |
| | | Bucket cylinder line hoses | |

12,000 HOUR / 6 YEAR SERVICE

Hose In-service Lifetime Limit (European Standard ISO 8331 and EN982 CEN)

European regulations state that in-service life of any hydraulic hose may not exceed six years. DOOSAN recommends the following:

- Hoses at the customer premises cannot be stored more than 2 years before being discarded or installed on a machine.
- In-service lifetime of hoses fitted on a machine can never exceed 6 years, but replace hoses described in "Major Parts - Periodic Replacement" on page 4-63, every 2 years. Always replace hoses having exceeded the allowed in-service lifetime irrespective of the external appearance/wear.
- Always store hoses in a dark place at a maximum of 65% relative humidity, between 0°C (32°F) and 35°C (95°F) but as close as possible to 15°C (59°F) and away from copper, manganese or tube generating Ozone.

AIR-CONDITIONING SYSTEM

NOTE: See "Clean Air-Conditioning Outer Filter" on page 4-39.

Check Control Panel

When a function switch is pushed, the last setting has to be displayed on the LCD display.

When the light switch is turned to "I" position, the LED for illumination in the control panel has to turn "ON".

Check Air Conditioner Hoses

Check the hose for cracking and damage.



CAUTION

AVOID INJURY

When a leak occurs, dirt will accumulate in the area where the leak is. Consult a DOOSAN distributor or sales agency.

Check Condenser

Inspect the condenser for dust and debris. Clean if necessary.

NOTE: See "Clean Radiator, Oil Cooler, Intercooler, Fuel Cooler and Air Conditioner Condenser Core" on page 4-41.

Check Magnetic Clutch

Check the magnetic clutch for dirt and interference.

Push the "A/C" switch to energize magnetic clutch and check the magnetic clutch.

Check Belt Tension

NOTE: See "Check Engine Fan Belt Tension" on page 4-33.

BUCKET

Bucket Tooth Replacement



WARNING

AVOID DEATH OR SERIOUS INJURY

Due to the possibility of flying metal objects, always wear safety helmet, protective gloves and eye protection when changing bucket teeth.

Curl the bucket upwards and place the round rear surface of the bucket firmly on the ground. Shut the engine off and lock out the hydraulic controls before working on the bucket.

NOTE: *These instructions are only for DOOSAN OEM buckets. If you are using other manufacturers buckets, refer to their specific instructions.*

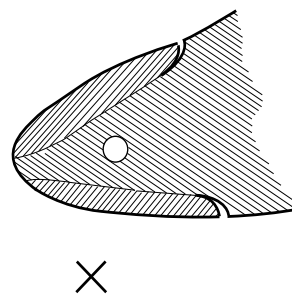
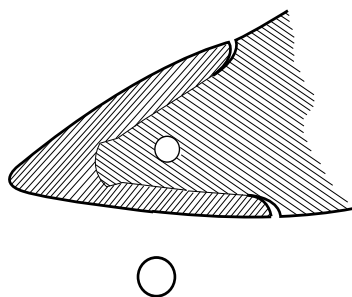

HAOC680L

Figure 113

1. On a routine basis, inspect bucket teeth to make sure that tooth wear or breakage has not developed. Do not allow replaceable bucket teeth to wear down to a point that bucket adapter is exposed. See Figure 113.
2. To replace a tooth (1, Figure 114), use a hammer and punch to drive locking pin (2) and lock washer (3) out of tooth adapter (4).
3. Once worn tooth has been removed, use a putty knife to scrape adapter as clean as possible.
4. Slide new tooth into position and insert lock washer.
5. Insert locking pin into tooth and with a hammer, drive pin in until lock washer seats in locking groove.

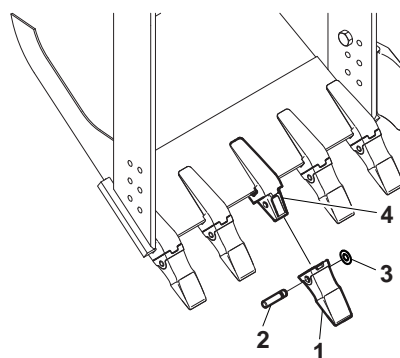

FG000346

Figure 114

Bucket O-ring Replacement



WARNING

AVOID DEATH OR SERIOUS INJURY

Due to possibility of flying metal objects, always wear safety helmet, protective gloves and eye protection when changing pins.

1. Inspect bucket O-rings on a routine basis. If worn or damaged, replacement is necessary.
2. Roll old O-ring (1, Figure 116) onto boss (2) around bucket pin (3). Remove bucket pin and move arm or bucket link (4) out of way.

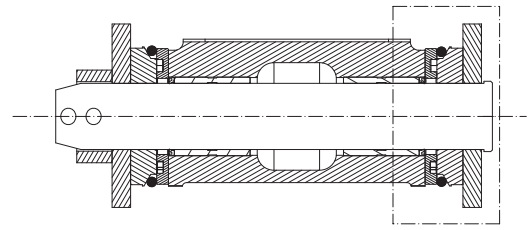

FG006750

Figure 115

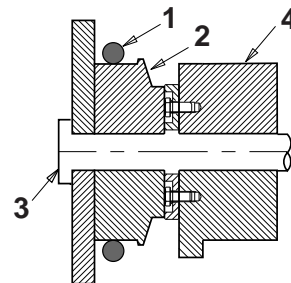

ARO1390L

Figure 116

3. Remove old O-ring and temporarily install new O-ring (1, Figure 117) onto bucket boss (2). Make sure that O-ring groove on both bucket link (4) and boss have been cleaned.
4. Realign arm or link with bucket pin hole and insert bucket pin (3, Figure 116).

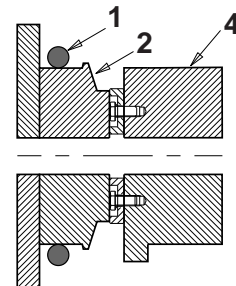

ARO1391L

Figure 117

5. Roll new O-ring (1, Figure 118) into O-ring groove.

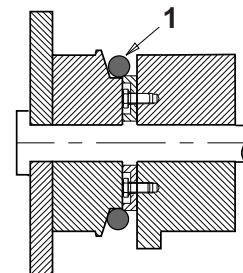

ARO1392L

Figure 118

ELECTRICAL SYSTEM

NOTE: *Never disassemble electrical or electronic parts. Consult with a DOOSAN distributor or sales agency before servicing.*

Battery



WARNING

AVOID DEATH OR SERIOUS INJURY

Battery electrolyte contains sulfuric acid and can quickly burn the skin and eat holes in clothing. If you spill acid on yourself, immediately flush the area with water.

Battery acid could cause blindness if splashed into the eyes. If acid gets into the eyes, flush them immediately with large quantities of water and see a doctor at once.

If you accidentally drink acid, drink a large quantity of water or milk, beaten egg or vegetable oil. Call a doctor or poison prevention center immediately.

When working with batteries, always wear safety glasses or goggles.

Battery generates hydrogen gas, so there is danger of an explosion. Do not bring lighted cigarettes near the battery, or do anything that will cause sparks.

Before working with batteries, stop engine and turn the starter switch to "O" (OFF) position.

Avoid short circuiting the battery terminals through accidental contact with metallic objects, such as tool.

When removing or installing, check which is the positive (+) terminal and negative (-) terminal.

When removing the battery, first disconnect the negative (-) terminal. When installing the battery, first connect the positive (+) terminal.

If the terminals are loose, there is danger that the defective contact may generate sparks that will cause an explosion. When installing the terminals, install them tightly.

Batteries in Cold Weather

In colder weather a greater drain is placed on the batteries when they are used for the preheat cycle and when starting a cold engine. Battery performance decreases as the temperature gets lower.

In extremely cold weather, remove batteries at night and move them to a warm location. This will help to keep them at a higher power level.

Inspection of Battery Electrolyte Level

This machine has two maintenance free batteries. They never require the addition to water.

When the charge indicator becomes transparency, it means low electrolyte state because of the leakage or charging system error. Determine the cause of problem and replace the batteries immediately.

Check Charging State

Check charging state through the charging indicator.

- GREEN: Sufficiently charged.
- BLACK: Insufficient charged.
- TRANSPARENT: Replace battery.

Check the Battery Terminals

Be certain that the battery is held securely in its compartment. Clean the battery terminals and the battery cable connectors. A solution of baking soda and water will neutralize acid on the battery surface, terminals, and cable connectors. Petroleum jelly or grease can be applied to the connectors to help prevent corrosion.

Battery Replacement

When the charging indicator indicates transparency state, replace the battery. The batteries should always be replaced in pairs.

Using an old battery with a new one will shorten the life span of the new battery.

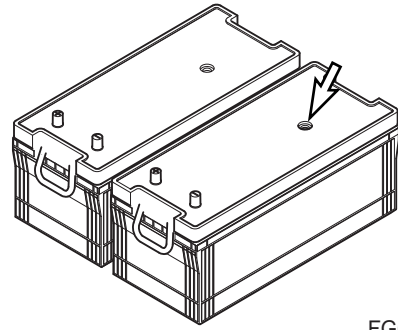

FG000347

Figure 119

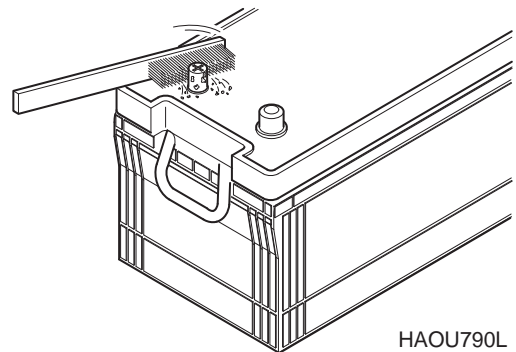

HAOU790L

Figure 120

Fuses

1. The fuses in the fuse box are used to protect the various electrical circuits and their components from being damaged. See Figure 121. The fuses used are standard automotive type fuses.
2. The section on "Fuse Identification" on page 4-71, lists the circuits and the fuse amperage required for each circuit. If a fuse blows, determine the cause and repair any faults or failures.
3. Do not insert a higher amperage fuse into a lower amperage slot. Serious damage to the electrical components or fire can result.

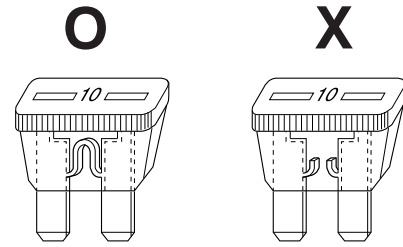

HAOC670L

Figure 121



CAUTION

AVOID INJURY

Before replacing a fuse, be sure to turn starter switch to "O" (OFF) position.

Fuse Boxes

There are two fuse boxes (Figure 122) in the right cover behind the seat. The fuses prevent electrical devices from overloading or shorting.

A decal attached inside the fuse box's cover indicates the function and amperage of each fuse.

Spare fuses are mounted on the inside of fuse box's cover. (One each of a 10A, 15A, 20A and 30A.)

Change a fuse if the element separates. If the element of a new fuse separates, check the circuit and repair the circuit.

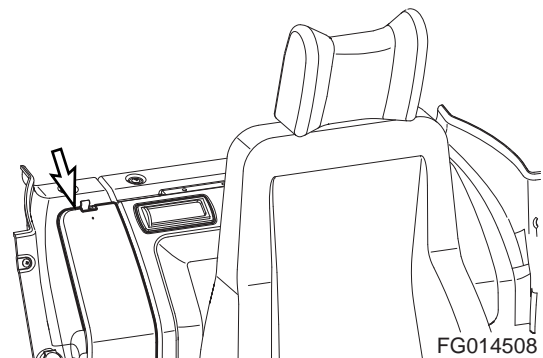

Figure 122



CAUTION

AVOID INJURY

Always replace fuses with the same type and capacity fuse that was removed. Otherwise, electrical damage could result.

Fuse Identification

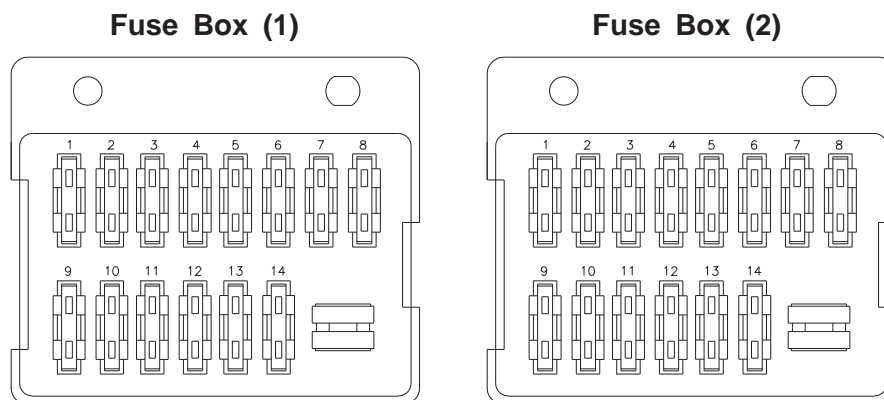

FG004974

Figure 123

| No. | Fuse Box One | |
|-----|--|----------|
| | Name | Capacity |
| 1 | Warning Light (Optional) | 10A |
| 2 | 2-pump (Optional) | 10A |
| 3 | Cigar Lighter | 10A |
| 4 | 12V Power | 10A |
| 5 | Wiper, Washer | 10A |
| 6 | Lower Wiper (Optional) | 10A |
| 7 | Stereo | 10A |
| 8 | Starter Switch, Hour Meter | 10A |
| 9 | Spare | 30A |
| 10 | Air Conditioner, Heater | 20A |
| 11 | Shear, Breaker (Optional) | 20A |
| 12 | Seat Heater (Optional) | 15A |
| 13 | EPOS, Booster, Travel speed changer, Booster | 15A |
| 14 | ECU | 15A |

| No. | Fuse Box Two | |
|-----|-----------------------------------|----------|
| | Name | Capacity |
| 1 | Horn | 10A |
| 2 | Quick Coupler (Optional) | 10A |
| 3 | Travel Alarm (Optional) | 10A |
| 4 | Auxiliary Mode | 10A |
| 5 | Check Connector | 10A |
| 6 | Pilot Cutoff | 10A |
| 7 | Memory Backup | 10A |
| 8 | Room Light | 10A |
| 9 | Cabin Light (Optional) | 30A |
| 10 | Work Light | 20A |
| 11 | Fuel Heater | 20A |
| 12 | Instrument Panel, Pressure Sensor | 15A |
| 13 | Headlight | 15A |
| 14 | Fuel Pump (Optional), Wiper | 15A |

ENGINE COOLING SYSTEM

General

Keeping an engine's cooling system in peak operating condition can have many benefits in keeping a machine in good operating condition. A properly functioning cooling system will improve fuel efficiency, reduce engine wear, and extend component life.

Always use distilled water in the radiator. Contaminants in tap water neutralize the corrosion inhibitor components. If tap water must be used, Refer to "Table of Standards for Allowed Tap Water" on page 4-74. Water that has been treated with a water softener also contains salt that will cause corrosion of components. Water from creeks and stagnant pools usually contain dirt, minerals and/or organic material that are deposited in the cooling system and impair cooling efficiency. As such, the use of distilled water is recommended.

Engine coolant shall be mixed with antifreeze solution and water in ratio of 50 : 50.

Coolant shall be checked every 500 hours of operation for ensuring adequate concentration of antifreeze solution and additives.

Engine overheating is often caused by bent or clogged radiator fins. The spaces between the fins can be cleaned by use of air or water under pressure. When straightening bent fins, use care not to damage the tubes or break the bonding joint between the fins and the tubes.



WARNING

AVOID DEATH OR SERIOUS INJURY

Pressure at air nozzle must not exceed 2 kg/cm² (28 psi). Always wear goggles when using compressed air.

Do not pour cold water into radiator when engine is hot and water level is below the top of the tubes. Such action could result in damage to engine cylinder heads.

Heavy-duty diesel engines require a balanced mixture of water and antifreeze. Drain and replace the mixture 1 year or 2,000 hours of operation, whichever comes first. This will eliminate buildup of harmful chemicals.

Antifreeze is essential in any climate. It broadens the operating temperature range by lowering the coolant's freezing point and by raising its boiling point. Do not use more than 50% antifreeze in the mixture unless additional antifreeze protection is required. Never use more than 60% antifreeze under any condition.

Types of Antifreeze

Ethylene Glycol - DOOSAN Genuine Antifreeze Solution
(for all seasons)

Ethylene glycol is a very hazardous material to human beings, animals and environment. Drain of coolant must be disposed of by an authorized waste material treatment service provider.

The color does not provide a standard. Unauthorized coolant may have the same color. Please check the label on the container. Use genuine product.

IMPORTANT

Do not mix solutions from different manufacturers. Otherwise, the performance may be deteriorated. It is recommended to use the standard product from DOOSAN.

In extreme temperatures, the performance of the coolant must be checked frequently and the coolant change cycle adjusted as necessary.

Engine parts that are made of aluminum are quickly worn out by nitrite, and therefore you should make sure to use nitrite-free coolant.

Antifreeze Concentration Tables

| Ethylene Glycol - DOOSAN Genuine Antifreeze Solution (for all seasons) (2,000 Hour/1 Year) | | |
|---|---------------|------------|
| Ambient Temperature | Cooling Water | Antifreeze |
| -20°C (-4°F) | 67% | 33% |
| -25°C (-13°F) | 60% | 40% |
| -30°C (-22°F) | 56% | 44% |
| -40°C (-40°F) | 50% | 50% |

NOTE: The concentration shall be kept at 50% and in worst case at 30% minimum for the least corrosion resistance.

NOTE: Replacement cycle of the DOOSAN Genuine Product is 2,000 hours or one year.

Table of Standards for Allowed Tap Water

| Requirement | | | | | |
|-------------|--------------------|----------|----------------|--------------|-----------|
| Item | Inorganic chloride | Sulfates | Total Hardness | Total Solids | Acidity |
| Value | < 40 ppm | < 50 ppm | < 9.5° d.H | < 340 ppm | 5.5 - 9.0 |

PPM (Parts Per Million) - Unit of concentration of minor materials.

- 1 ppm = 1 mg/1 kg, 1 mL/1 L

° d.H - Unit of concentration of minor materials.

- 1° d.H = 17 ppm



CAUTION

AVOID INJURY

The standard of tap water is for reference only, and may not be regarded as a standard.

If quality of the water is not trustable, stop using tap water whenever possible and use distilled water.

FUEL TRANSFER PUMP (OPTIONAL)

IMPORTANT

Dry operating fuel pump for more than fifteen seconds can cause wear and/or damage to pump.

- Cooling and lubrication of pump is achieved by fuel passing through pump. If pump is dry operated, heat generated by moving parts will cause damage to pump rotors, vanes and seals.

Do not operate pump for more than fifteen minutes at a time.

- Continuous usage of pump over recommended time interval will cause overheating of motor and will result in causing motor damage.

Do not use refueling pump for other types of fuel or fluids. (Use only for diesel fuel.)

- Do not use refueling pump for other types of fuel which have a low flash point.
- Do not use refueling pump for fuel contaminated with water or high humidity. Moisture in pump mechanism can cause rust and can create pump failure.

Always operate pump using strainer installed on inlet hose. This will prevent any foreign materials from being introduced into pump. Always maintain pump and all of its components in a clean condition.

- If dirt or other foreign materials enter pump, it can become lodged between the rotor and/or vanes and generate heat which can cause pump damage.
- Do not remove strainer or use a strainer with larger mesh to increase flow of fuel.

Be careful not to overfill or spill fuel.

Make sure direction of check valve is in line with flow direction of fuel.

If any pump parts or components become lost, damaged or inoperable, immediately replace it with a new ones.



WARNING

AVOID DEATH OR SERIOUS INJURY

If there are any sign of leakage while operating transfer pump, inspect the following components to prevent any fires or hazardous fuel spills.

- Check all hoses leading to and from the transfer pump.
- Check all hose clamps.
- Check transfer pump inlet port.

The transfer pump is used to transfer fuel from a refueling source to the fuel tank. A check valve is installed in the inlet hose to prevent fuel from flowing back from fuel tank to source. A strainer is installed in inlet hose to prevent any foreign material from being introduced into transfer pump or fuel tank.

A thermal limiter, built into the motor, will automatically shut off power if motor is overheating to protect it from being damaged.

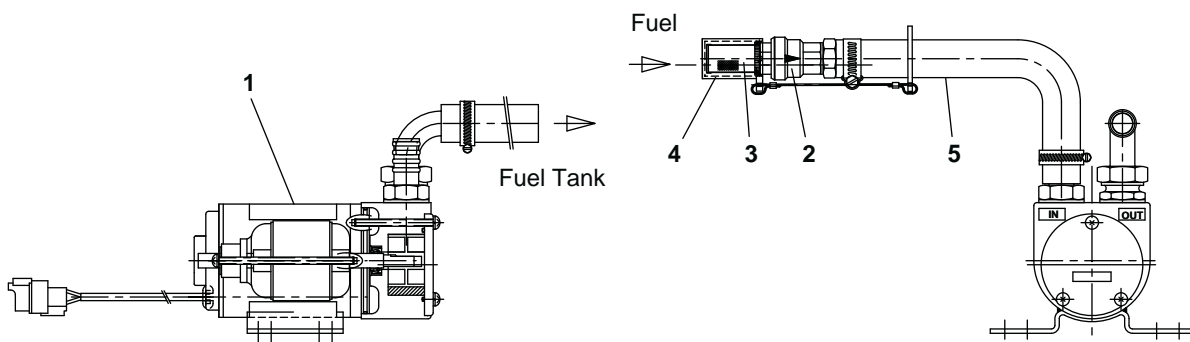

FG000161

Figure 124

| Reference Number | Description |
|------------------|-------------|
| 1 | Body |
| 2 | Check Valve |
| 3 | Strainer |

| Reference Number | Description |
|------------------|--------------|
| 4 | Strainer Cap |
| 5 | Inlet Hose |

1. Remove strainer cap (4, Figure 124) from strainer (3) on end of inlet hose (5).

NOTE: *Keep strainer cap (4, Figure 124) in a safe location to reseal strainer (3) after refueling is complete.*

2. Insert inlet hose (5, Figure 124) into refueling tank.
3. Turn fuel pump switch (Figure 125) inside of battery box on front side to "I" (ON) position.

NOTE: *Transfer pump rate of flow is approximately 35 lpm (9.24 U.S. gpm). Use extra care not to overfill fuel tank so fuel does not over flow.*

4. Once fuel transfer is completed, immediately turn switch to "O" (OFF) position to stop pump.
5. Lift inlet hose (5, Figure 124) from fueling source and turn switch to "I" (ON) position for two - three seconds to drain remaining fuel from hose to fuel tank.
6. Install strainer cap (4, Figure 124) on inlet strainer (3) and return hose (5) to storage position.

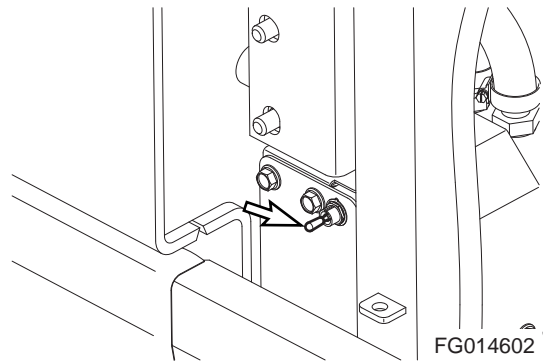

Figure 125

HANDLING OF ACCUMULATOR



WARNING

AVOID DEATH OR SERIOUS INJURY

Even though the engine is stopped, the hydraulic accumulators for the pilot system are still charged. Do not disconnect any pilot system hoses until accumulator pressure has been released from the circuit. To release pressure, turn the starter switch to "I" (ON) position and operate all hydraulic control levers and forward/reverse travel levers. Even though the engine is shutdown hydraulic actuated components may move while releasing pilot pressure. Keep all personnel away from excavator while performing this operation.

- Move safety lever to "LOCK" position after stopping engine.
- DO NOT mishandle accumulator(s). They are very dangerous because they contain high-pressure nitrogen gas.
- DO NOT punch a hole or apply heat or fire to an accumulator.
- DO NOT weld on accumulator, or try attaching anything to it.
- When replacing an accumulator, contact a DOOSAN distributor or sales agency so the gas can be properly released.
- Wear safety goggles and protective gloves when working on an accumulator. Hydraulic oil under pressure can penetrate the skin and cause serious injuries.

Release pilot accumulator pressure using the following procedure:

1. Park machine on firm and level ground. Lower the front attachment to the ground and stop engine.
2. Move safety lever to "RELEASED" position.
3. Turn starter switch to "I" (ON) position.
4. Fully stroke work and travel levers in all directions.
5. Move safety lever to "LOCK" position.
6. Turn key to "O" (OFF) position and remove from starter switch.
7. Remove accumulator by unscrewing it slowly.

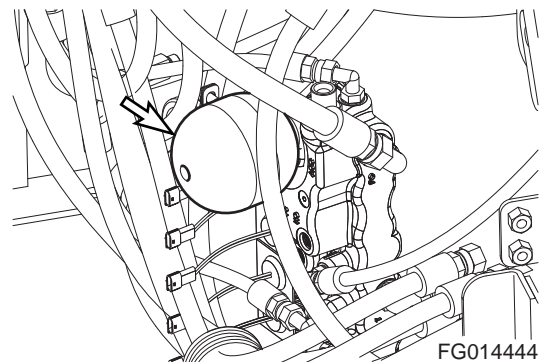

Figure 126

TRACK TENSION



WARNING

AVOID DEATH OR SERIOUS INJURY

Measuring track tension requires two people. One person must be in the operator's seat, operating the controls while the other person makes dimensional checks. Block frame to make sure the machine won't move or shift position during service. Warm up the engine to prevent stalls, park the excavator in an area that provides level, uniform ground support and/or use support blocks when necessary.

NOTE: *The track tension must be adjusted in accordance with the operating conditions. If a lot of dust stick to the track assembly in the working place, keep the track as loose as possible.*

Track shoe link pins and bushings wear with normal usage, reducing track tension. Periodic adjustment is necessary to compensate for wear and it may also be required by working conditions.

1. Track tension is checked by jacking up one side of the excavator. See Figure 127. Place blocking under frame while taking measurement.

Turn the track backward 1 ~ 2 turns.

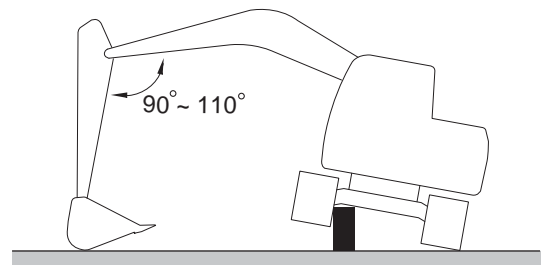

EX1300536

Figure 127

2. Measuring the distance (A, Figure 128) between the bottom of the side frame and the top of the lowest crawler shoe. Recommended tension for operation over most types of terrain is as below table.

NOTE: *Clean off the tracks before checking clearance for accurate measurements.*

3. Too little sag in the crawler track (less than clearance distance "A" on below table) can cause excessive component wear. The recommended adjustment can also be too tight causing accelerated stress and wear if ground conditions are wet, marshy or muddy.

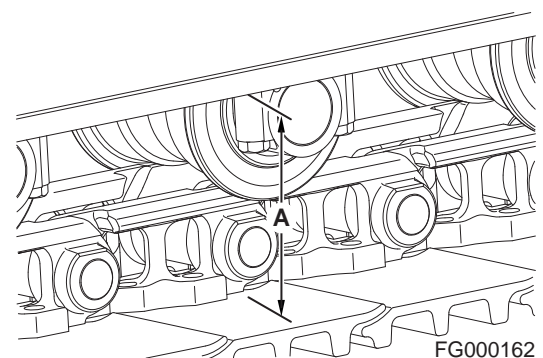

FG000162

Figure 128

- A track that is properly adjusted may have a different sag according to the track options. Contact your dealer for information.

| Terrain Type | Distance "A" |
|--------------|----------------------------------|
| Normal | 275 ~ 305 mm (10.8 ~ 12.0 in) |



WARNING

AVOID DEATH OR SERIOUS INJURY

The track adjusting mechanism is under very high-pressure. **NEVER** release grease pressure too fast. The track tension grease valve should never be loosened more than one (1) complete turn from the fully tightened down position. Bleed off grease pressure slowly. Keep your body away from the valve always. Always wear eye and face protection when adjusting track tension.

- Track tension adjustments are made through the grease fitting (1, Figure 129) in the middle of each side frame. Adding grease increases the length of an adjustment cylinder (2). Extending the adjustment cylinder, increases the pressure on the tension spring pushing the track idler wheel outward.
- If there is not enough slack or clearance in the tracks and the adjustment is too tight, the idler wheel and adjusting cylinder can be retracted by bleeding off grease through hole in adjustment cylinder (2, Figure 129).

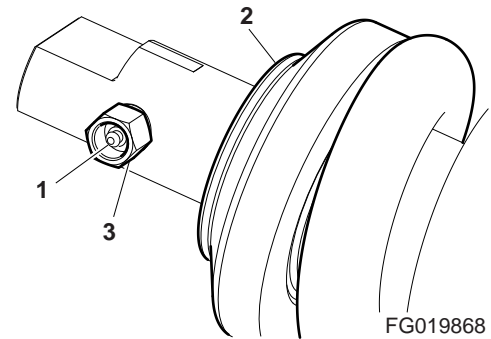

Figure 129

FG019868

VENTING AND PRIMING HYDRAULIC SYSTEM

Main System Pump

NOTE: *If pump is run without sufficient oil in the main hydraulic pump, damage can occur. Always vent pump of air after draining hydraulic system.*

1. With the engine stopped, remove vent plug (Figure 130) to see if any oil is present.
2. If oil is not present, fill pump with oil through port (Figure 130).
3. Install vent plug (Figure 130) first.
4. Start engine and run it for several minutes at low idle engine speed. This will pressurize the hydraulic oil tank and system.
5. Slowly loosen vent plug (Figure 130) several turns, until hydraulic oil flows out of plug. This shows that air has been released.
6. Tighten the plug (Figure 130).

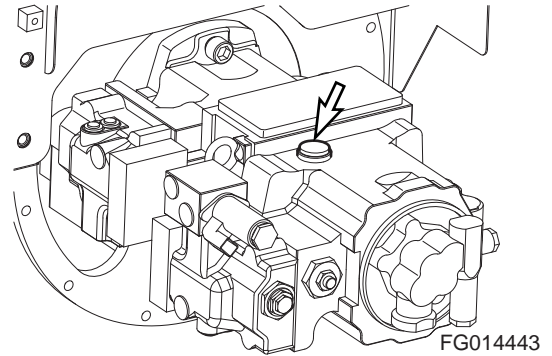

Figure 130

FG014443

Hydraulic Cylinders

IMPORTANT

If cylinders are operated in high idle after the hydraulic system has been drained or the cylinder has been rebuilt, damage to piston packing and seals can occur. Always vent air from cylinders at low idle and at a slow speed.

1. Run engine at low idle. Extend and retract each cylinder to within 100 mm (4 in) of fully stroking it 4 - 5 times.
2. Operate fully extend and retract each cylinder 3- 4 times.
3. Repeat procedure until cylinders extend and retract smoothly.

Swing Motor

IMPORTANT

If the air is not vented from the system, it will cause damage to the swing motor and bearings.

NOTE: *Perform this only when oil has been drained from swing motor.*

1. Stop engine.
2. Disconnect drain hose and fill swing motor case with hydraulic oil.
3. Connect the drain hose.
4. Start engine and set throttle at "LOW IDLE" and swing upper structure slowly two full revolutions to the left and right.

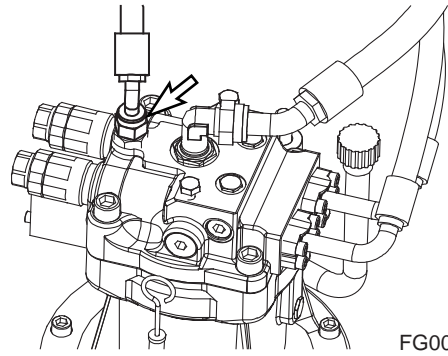

FG009596

Figure 131

Travel Motor

NOTE: *Perform this only when oil is drained from travel motor*

1. Stop engine
2. Disconnect drain hose (Figure 132) and fill motor case with hydraulic oil.
3. Connect drain hose.
4. Start engine and set engine speed control dial to "LOW IDLE". Run the engine for one minute and slowly drive excavator forwards and backwards.

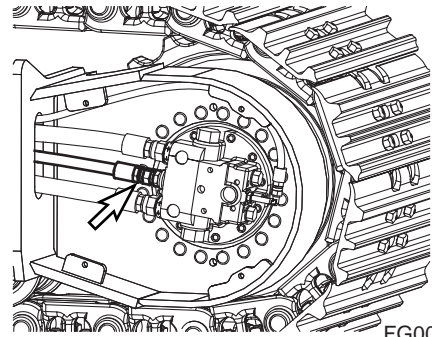

FG009597

Figure 132

General Venting

1. After venting air from all components, stop engine and check the hydraulic oil level. Fill hydraulic oil tank to "H" mark on sight gauge.
2. Start engine and operate all controls again, run engine for five minutes to ensure all systems have been vent and purged of air. Move engine speed to "LOW IDLE", and check hydraulic oil level again. Add oil as necessary.
3. Check for oil leaks and clean all fill and venting locations.

LONG TERM STORAGE

Perform the following if storing the excavator for more than one month.

| Conditions | Maintenance Required |
|------------------|--|
| Cleaning | Pressure wash the undercarriage and track assemblies. Inspect for damage or loose or missing parts. |
| Lubrication | Perform all daily lubrication procedures. |
| | Apply a coating of light oil to the exposed plated metal surfaces, such as hydraulic cylinder rods, etc. |
| | Apply a coating of light oil to all of the control linkages and control cylinders (control valve spools, etc.). |
| Battery | Remove the battery from the excavator or remove the battery leads from the battery to fully charge and store. |
| Cooling System | Inspect the coolant recovery tank to make sure that the antifreeze level in the system is at the correct level. |
| | Every 90 days, use a hydrometer to measure the protection level of the coolant. Refer to the antifreeze/coolant protection chart to determine the amount of protection the cooling system requires. Add coolant as required. |
| Hydraulic System | Once a month, start the engine and follow the "Hydraulic Oil Warm-up" procedures listed in this manual. |

MAINTENANCE IN SPECIAL CONDITIONS

NOTE: See "Operation Under Unusual Conditions" on page 3-43 for other recommendations.

| Conditions | Maintenance Required |
|---|---|
| Operating in mud, water or rain. | Perform a walk around inspection to check for any loose fittings, obvious damage to the machine or any fluid leakage. |
| | After completing operations, clean mud, rocks or debris from the machine. Inspect for damage, cracked welds or loosened parts. |
| | Perform all daily lubrication and service. |
| | If the operations were in salt water or other corrosive materials, make sure to flush the affected equipment with fresh water. |
| Operating in an extremely dusty or hot environment. | Clean the air intake filters on a more frequent basis. |
| | Clean the radiator and oil cooler fins to remove embedded dirt and dust. |
| | Clean the fuel system intake strainer and fuel filter more frequently. |
| | Inspect and clean as required the starter and alternator. |
| Operating in rocky terrain. | Check the undercarriage and track assemblies for damage or excessive wear. |
| | Inspect for loose or damaged fittings or bolts. |
| | Relax track tension. |
| | On a more frequent basis, inspect the front end attachments for damage or excessive wear. |
| | Install a top guard and front guard as required for protection against falling rock. |
| Operating in extreme cold. | Use the proper fuel for the temperature conditions. |
| | Using a hydrometer, check the antifreeze to make sure that it is providing the proper cold weather freeze protection. |
| | Verify the condition of the batteries. In extremely cold weather remove the batteries at night and store them in a warmer area. |
| | Remove mud buildup as soon as possible to prevent it from freezing to the undercarriage and causing damage. |

Transportation

Obey all local, state or federal regulations for the transportation of the excavator. If unsure of regulations check with local authorities.

Check the intended route for road width, overhead clearances, weight restrictions, and traffic control regulations. Special approval or permits may be required.

LOADING AND UNLOADING

Warning for Counterweight and Front Attachment Removal



DANGER

AVOID DEATH

DOOSAN warns any user, that removal of the counterweight from the machine, front attachment or any other part, may affect the stability of the machine. This could cause unexpected movement, resulting in death or serious injuries. DOOSAN is not liable for any misuse.

Never remove counterweight or front attachment unless the upper structure is in-line with the lower structure.

Never rotate the upper structure once the counterweight or front attachment has been removed.

×

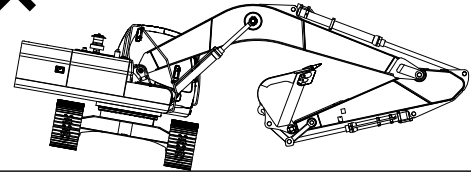

×

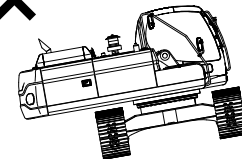

FG000371

Figure 1



WARNING

AVOID DEATH OR SERIOUS INJURY

When transporting the machine, know the width, height, length and weight.

Loading or unloading the machine can be a dangerous operation. Make sure to run the engine at the lowest speed setting, and travel at the slowest speed possible.

Make sure that ramp being used can handle the weight of the machine. If required, add blocking under the ramp for additional support.

Make sure that ramp surface is free of grease or mud that could cause the machine to slip or slide.

Make sure that trailer is parked on firm and level ground before attempting to load/unload the excavator.

If it is required to turn the machine while it is on the trailer, make sure to do this at the slowest engine and travel speeds possible.

Make sure to secure the excavator onto the trailer as required by local transportation laws.

| Total Height | Total Width | Total Length | Weight | Remarks |
|---------------------|---------------------|----------------------|----------------------------------|---------------------------------------|
| 2,795 mm (9' 2") | 2,800 mm (9' 2") | 7,230 mm (23' 7") | 14.4 metric tons (15.87 tons) | 5.2 m Boom 2.6 m Arm 600 G Shoe |

1. Make sure that trailer is parked on firm and level ground. See Figure 2.
2. Make sure that ramps that are being used are designed to handle the weight of the excavator. If required, add blocking under the ramp to provide additional support.
3. The ramp angle must be less than or not exceeding a 15° angle. Ramps steeper than this can cause a problem when loading or unloading.

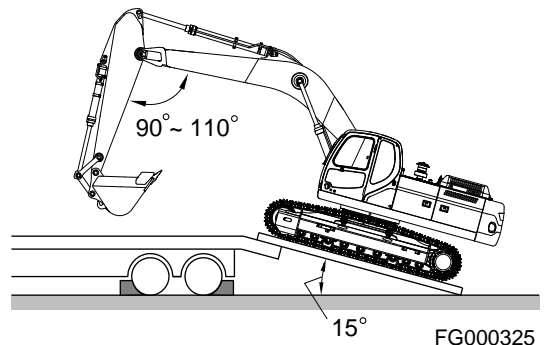
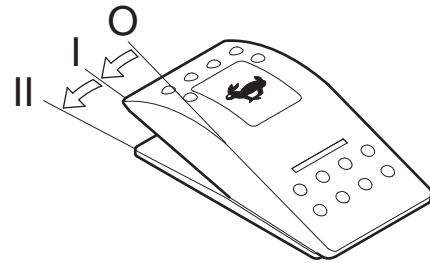

Figure 2

- Set the travel speed selector switch to "O" (OFF) position. See Figure 3.



FG000023

Figure 3

- Turn "OFF" auto idle selector button (1, Figure 4). The indicator symbol will be disappeared.
- Move engine speed to "LOW IDLE".

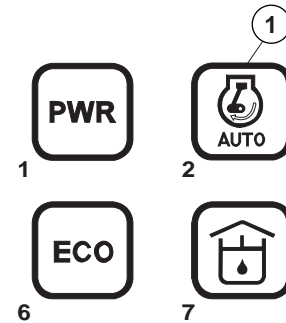

FG013833

Figure 4

- If the machine is equipped with work equipment, set the work equipment at the front, and travel forward to load it.

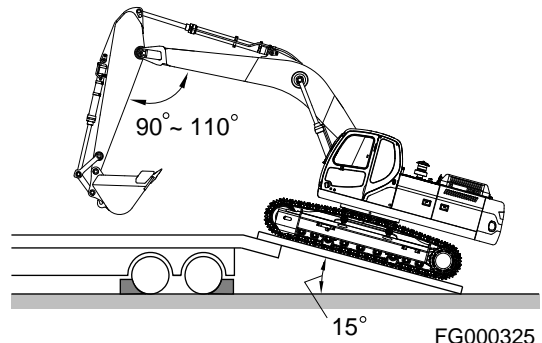

FG000325

Figure 5

- The unit does not require disassembly for normal over-the-road transportation. If the boom and arm need to be removed, the counterweight will place more weight on the rear of the machine. Make sure to back the excavator onto the trailer so the counterweight end of the excavator is positioned on the ramp first. See Figure 6.

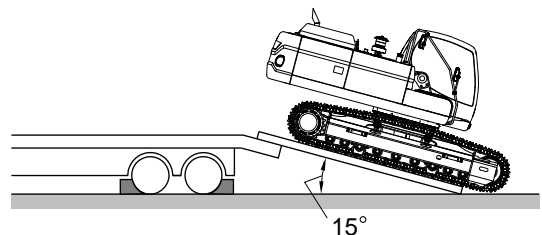

FG000326

Figure 6

9. Extend bucket and arm cylinders to maximum length and then lower the boom slowly.

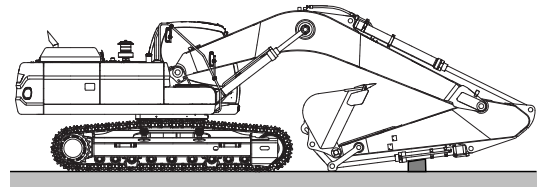

FG000327

Figure 7

10. Move safety lever to "LOCK" position.

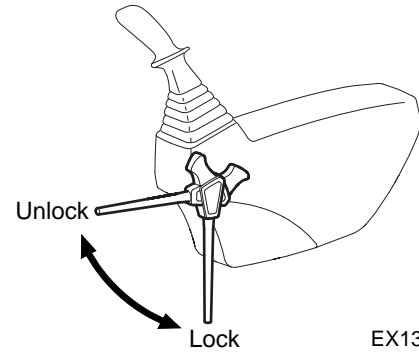

EX1300566

Figure 8

11. Stop engine by turning key to "O" (OFF) position (Figure 9).
12. Remove key from starter switch.

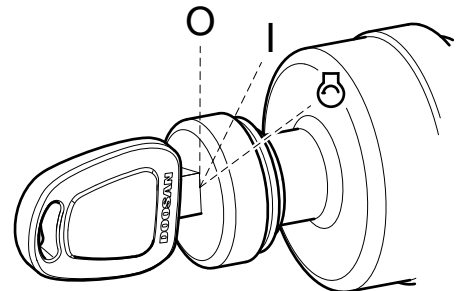

FG000175

Figure 9

13. Make sure to secure the excavator onto the trailer before transporting. Place blocking (1, Figure 10) in front of and behind each track. Tie front and rear (2, Figure 11) and tie down point (3, Figure 11) on the lower frame with wire cable as required by local transportation laws.
14. Refer to the Dimensions for Transportation table and drawing for overall machine height and width measurements. Make sure to position the excavator as shown. If not transported in this position, the height measurements may be different.

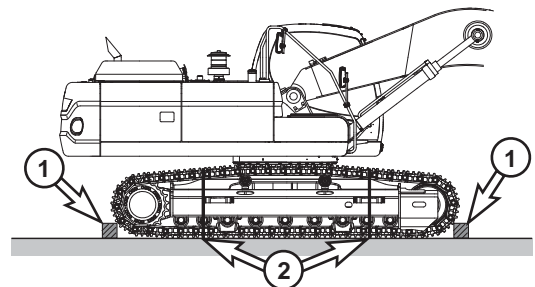

FG000334

Figure 10

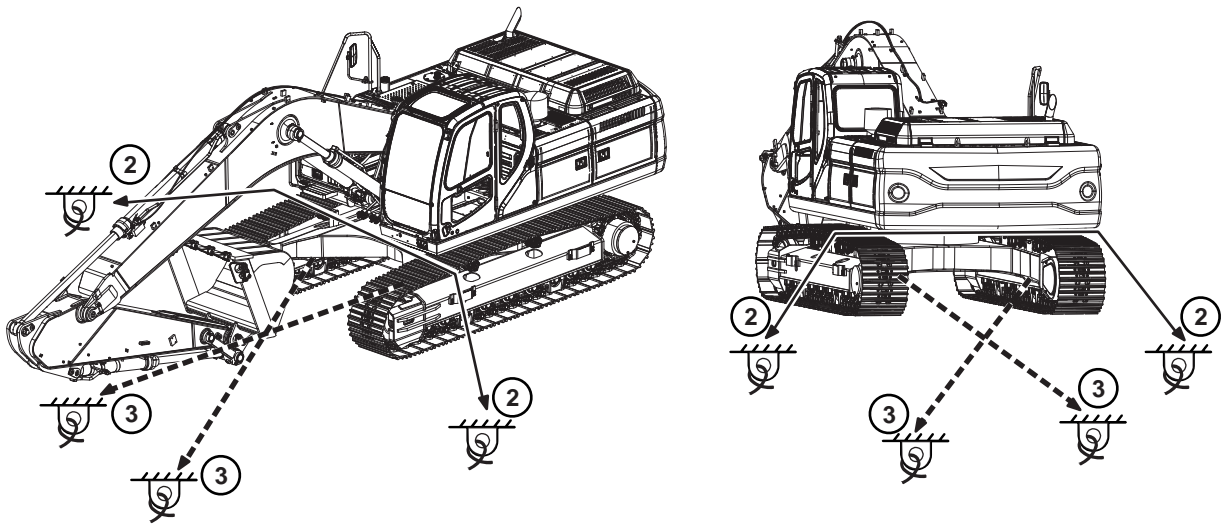

FG014870

Figure 11

LIFTING MACHINE



WARNING

AVOID DEATH OR SERIOUS INJURY

Never lift the machine with a person in the cabin or on the machine.

Never enter the area under or around a raised machine.

Improper lifting can allow load to shift and cause death or serious injury or property damage.

When lifting, move the safety lever to "LOCK" position to prevent the machine from moving unexpectedly.

Use only properly rated cables and slings

Never go in the area under or around the machine when it is raised.

Always use the posture given in the procedure below and use the proper lifting equipment to lift the machine.

1. Refer to "Specification" section of this manual for weight and dimensional information.
2. Lower the work equipment to the ground as shown in the diagram on the right
3. Lower the dozer blade to the ground. (if equipped)
4. Move safety lever to "LOCK" position. Stop engine.
5. Ensure that there is nothing around the operator's compartment, close the cab door and front glass securely.
6. Bind wire ropes between the 1st and 2nd track rollers from the front and between the 1st and 2nd track rollers from the rear.
7. Use spreader bars between the wire rope and the machine to prevent damage to the rope or machine. Set the lifting angle (1, Figure 12) of the wire rope to 30° - 40°.
8. After the machine comes off the ground, check the hook condition and the lifting posture, and then lift slowly.

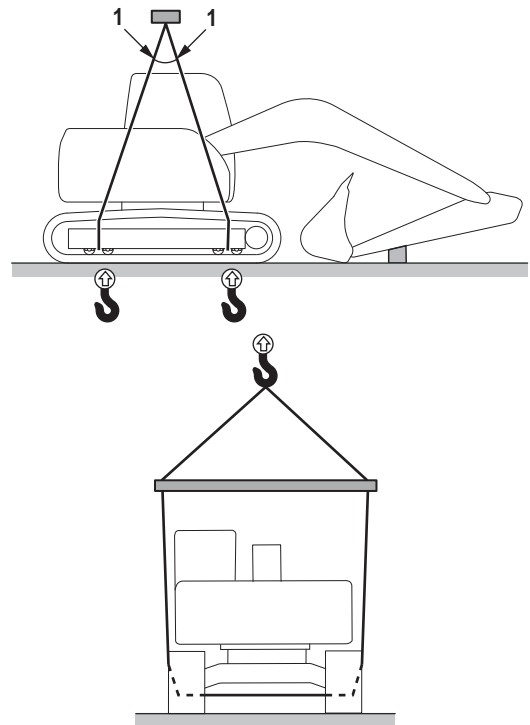

Figure 12

EX1300819

Specification

STANDARD SPECIFICATION

| Component | | Specification | | |
|--------------------|---|----------------------------|-----------------------|----------------|
| | | Metric | English | |
| Bucket Capacity | CECE | 0.51 m ³ | 0.67 yd ³ | |
| | PCSA | 0.59 m ³ | 0.77 yd ³ | |
| Operating Weight | | 14.3 metric tons | 15.8 tons | |
| Engine | Model | CUMMINS QSB 4.5 | | |
| | Type | Water Cooled - 4 Cylinders | | |
| | Rated Gross Output (Working Mode) | 110 ps @ 1,850 rpm | 108 hp @ 1,850 rpm | |
| | Rated Gross Output (Single Travel Mode) | 110 ps @ 2,000 rpm | 108 hp @ 2,000 rpm | |
| | Maximum Torque | 44.8 kg.m @ 1,400 rpm | 324 ft lb @ 1,400 rpm | |
| | Fuel Tank Capacity | 235 liters | 62.1 U.S. gal. | |
| Hydraulic Pump | Type | Axial Piston | | |
| | Discharging Pressure | 350 kg/cm ² | 5,000 psi | |
| | Maximum Discharge Quantity | 2 x 114 liters/min | 2 x 25.1 U.S. gpm | |
| | Hydraulic Oil Capacity | Tank Level | 85 liters | 22.4 U.S. gal. |
| | | Full | 131 liters | 34.6 U.S. gal. |
| System | | 161 liters | 42.5 U.S. gal. | |
| Performance | Digging Capability | Bucket | 11.1 metric tons | 12.2 tons |
| | | Arm | 6.0 metric tons | 6.6 tons |
| | Swing Speed | 10.8 rpm | | |
| | Travel Speed | High-speed | 5.0 km/h | 3.1 MPH |
| | | Low-speed | 3 km/h | 1.9 MPH |
| | Traction Force | High-speed | 7.25 metric tons | 8.0 tons |
| | | Low-speed | 12.5 metric tons | 13.8 tons |
| | Gradeability | 35° (70% slope) | | |
| Ground Pressure | 0.41 kg/cm ² | 5.8 psi | | |
| Ground Clearance | | 410 mm | 16.1 in | |
| Track Shoe Width | | 600 mm | 23.6 in | |
| Upper Roller Qty. | | 1 per side | | |
| Bottom Roller Qty. | | 7 per side | | |

OVERALL DIMENSIONS

One - Piece Boom

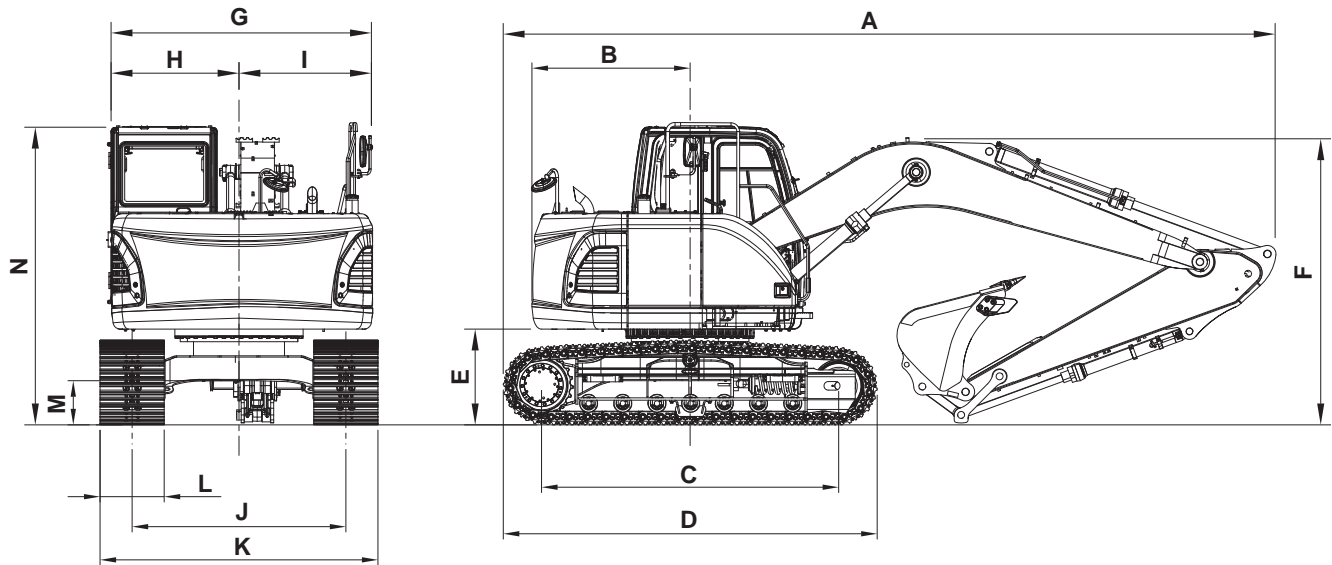

DS1800433

Figure 1

| Dimension | 4.6 m (15' 1") One - Piece Boom | | |
|-----------|---|---|---|
| | 2.1 m (6' 11") Arm | 2.5 m (8' 2") Arm | 3.0 m (9' 10") Arm |
| A | STD: 7,240 mm (23' 9") LC: 7,370 mm (24' 2") | STD: 7,230 mm (23' 9") LC: 7,360 mm (24' 1") | STD: 7,190 mm (23' 7") LC: 7,320 mm (24' 0") |
| B | 1,480 mm (4' 10") | | |
| C | DX140LCR: 3,035 mm (9' 11")/DX140R: 2,780 mm (9' 1") | | |
| D | DX140LCR: 3,755 mm (12' 4")/DX140R: 3,500 mm (11' 5") | | |
| E | 895 mm (2' 11") | | |
| F | 2,580 mm (8' 5") | 2,710 mm (8' 11") | 3,090 mm (10' 2") |
| G | 2,440 mm (8' 0") | | |
| H | 1,190 mm (3' 11") | | |
| I | 1,250 mm (4' 1") | | |
| J | 1,990 mm (6' 6") | | |
| K | 2,590 mm (8' 6") | | |
| L | 600 mm (2' 0") | | |
| M | 410 mm (1' 4") | | |
| N | 2,795 mm (9' 1") | | |

Two - Piece Boom

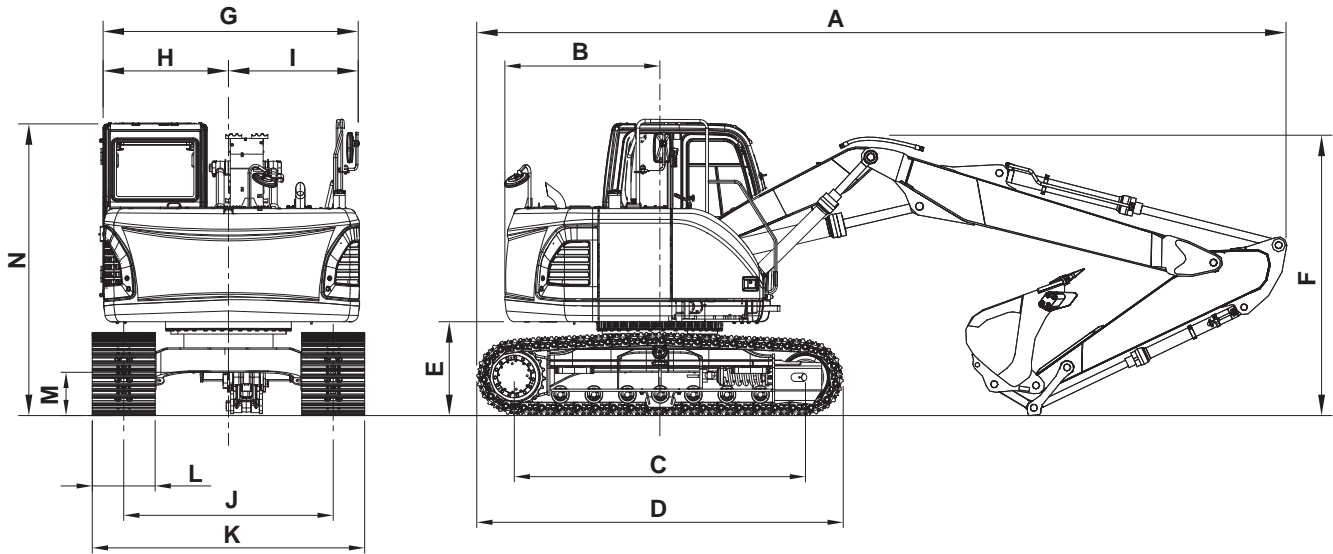

DS1800434

Figure 2

| Dimension | 4.98 m (16' 4") Two - Piece Boom | |
|-----------|---|-------------------|
| | 2.1 m (6' 11") Arm | 2.5 m (8' 2") Arm |
| A | 8,060 mm (26' 5") | 8,015 mm (26' 4") |
| B | 1,480 mm (7' 2") | |
| C | DX140LCR: 3,035 mm (9' 11")/DX140R: 2,780 mm (9' 1") | |
| D | DX140LCR: 3,755 mm (12' 4")/DX140R: 3,500 mm (11' 5") | |
| E | 895 mm (2' 9") | |
| F | 2,580 mm (8' 5") | 2,680 mm (8' 7") |
| G | 2,440 mm (8' 0") | |
| H | 1,190 mm (3' 9") | |
| I | 1,250 mm (4' 1") | |
| J | 1,990 mm (6' 6") | |
| K | 2,590 mm (8' 6") | |
| L | 600 mm (2' 0") | |
| M | 410 mm (1' 4") | |
| N | 2,795 mm (9' 1") | |

WORKING RANGE

One - Piece Boom

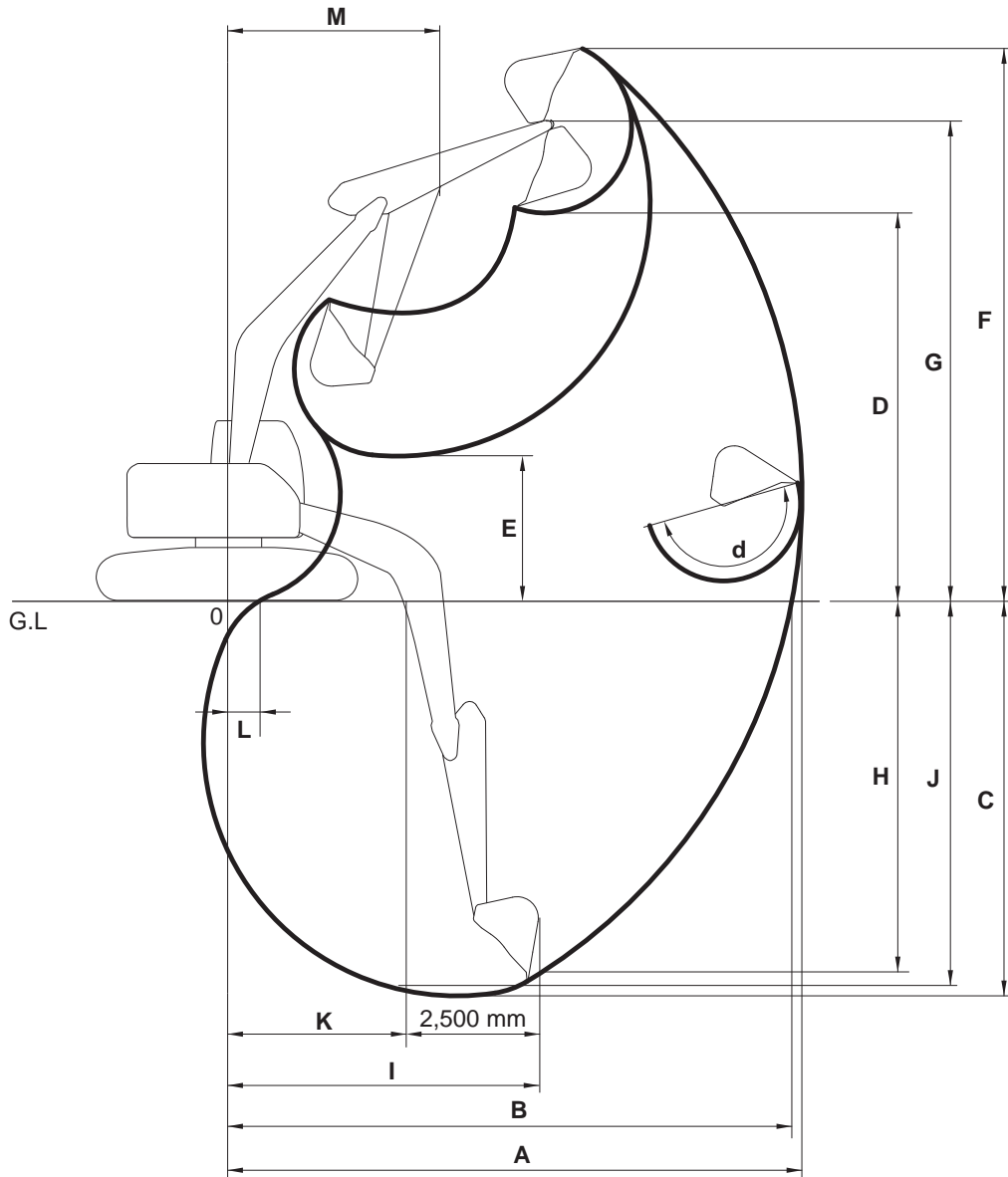

EX1500446

Figure 3

| DIM. | Boom | 4.6 m (15' 1") | | |
|------|-----------------------------|---|-------------------|---|
| | Arm | 2.1 m (6' 11") | 2.5 m (8' 2") | 3.0 m (9' 10") |
| | Bucket Type (PCSA) | 0.51 m ³ (0.67 yd ³) | | 0.39 m ³ (0.51 yd ³) |
| A | Max. Digging Reach | 7,845 m (25' 9") | 8,300 m (27' 3") | 8,680 m (28' 6") |
| B | Max. Digging Reach (Ground) | 7,690 m (25' 3") | 8,155 m (26' 9") | 8,540 m (28' 0") |
| C | Max. Digging Depth | 5,100 m (16' 9") | 5,500 m (18' 1") | 6,000 m (19' 8") |
| D | Max. Loading Height | 6,390 m (21' 0") | 6,840 m (22' 5") | 7,055 m (23' 2") |
| E | Min. Loading Height | 2,895 m (9' 6") | 2,505 m (8' 3") | 2,085 m (6' 10") |
| F | Max. Digging Height | 8,800 m (28' 10") | 9,280 m (30' 5") | 9,470 m (31' 1") |
| G | Max. Bucket Pin Height | 7,695 m (25' 3") | 8,185 m (26' 10") | 8,370 m (27' 6") |
| H | Max. Vertical Wall Depth | 3,810 m (12' 6") | 4,555 m (14' 11") | 4,735 m (15' 6") |
| I | Max. Radius Vertical | 5,690 m (18' 8") | 5,555 m (18' 3") | 5,925 m (19' 5") |
| J | Max. Depth to 2,500 mm Line | 4,410 m (14' 6") | 4,900 m (16' 1") | 5,480 m (18' 0") |
| K | Min. Radius 2,500 mm Line | 1,360 m (4' 6") | 1,360 m (4' 6") | 1,360 m (4' 6") |
| L | Min. Digging Reach | -35 m (-1' 11") | 350 m (1' 2") | 850 m (2' 9") |
| M | Min. Swing Radius | 1,885 m (6' 2") | 1,995 m (6' 7") | 2,290 m (7' 6") |
| d | Bucket Angle | 173° | 173° | 173° |

Two - Piece Boom

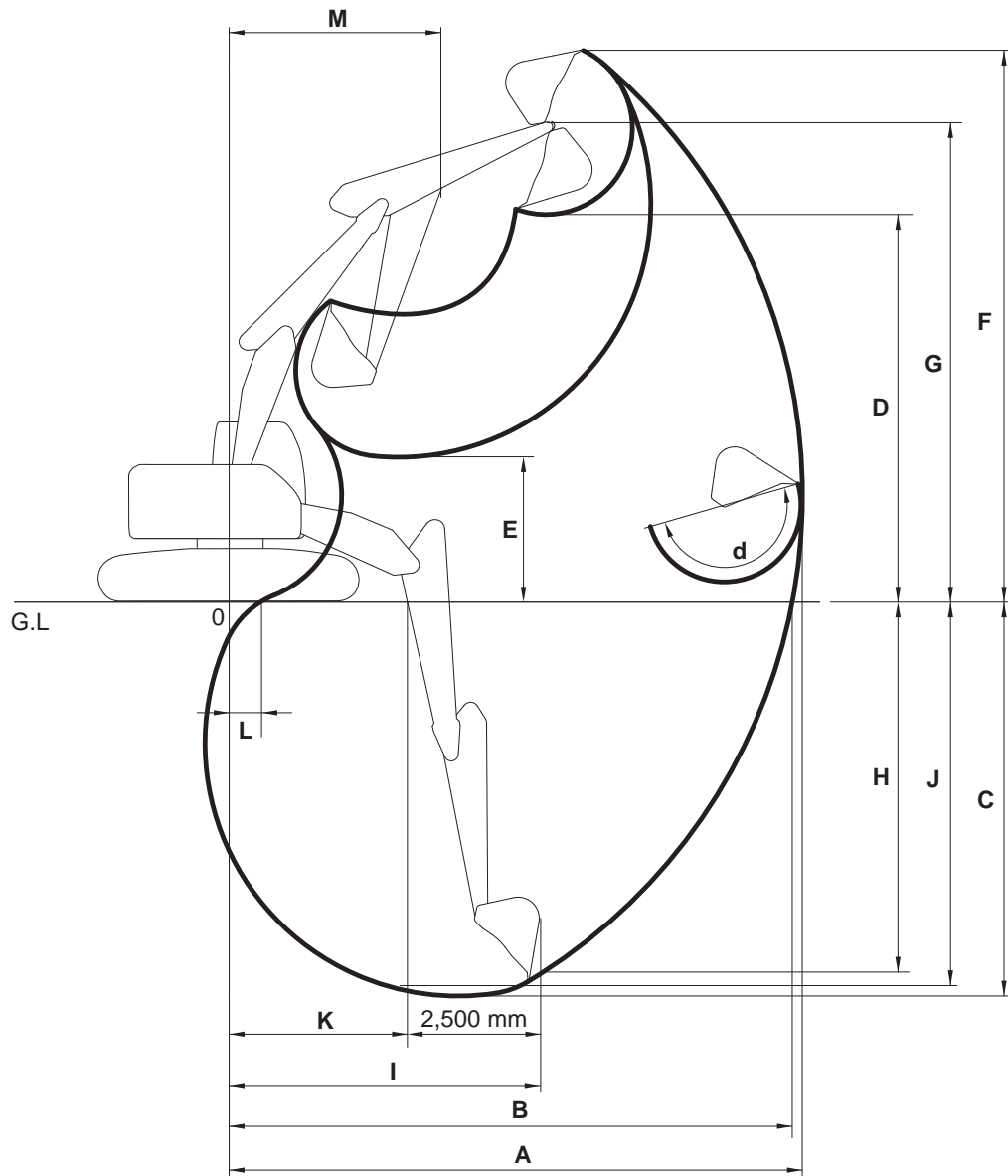

DS1801619

Figure 4

| DIM. | Boom | 4.6 m (15' 1") | |
|------|-----------------------------|---|-------------------|
| | Arm | 2.1 m (6' 11") | 2.5 m (8' 2") |
| | Bucket Type (PCSA) | 0.45 m ³ (0.59 yd ³) | |
| A | Max. Digging Reach | 8,270 m (27' 2") | 8,720 m (28' 7") |
| B | Max. Digging Reach (Ground) | 8,125 m (26' 8") | 8,584 m (28' 2") |
| C | Max. Digging Depth | 5,345 m (17' 6") | 5,735 m (18' 10") |
| D | Max. Loading Height | 6,605 m (21' 8") | 7,045 m (23' 1") |
| E | Min. Loading Height | 3,135 m (10' 3") | 2,740 m (9' 0") |
| F | Max. Digging Height | 8,975 m (29' 5") | 9,445 m (31' 0") |
| G | Max. Bucket Pin Height | 7,820 m (25' 8") | 8,260 m (27' 1") |
| H | Max. Vertical Wall Depth | 4,165 m (13' 8") | 4,715 m (15' 6") |
| I | Max. Radius Vertical | 5,805 m (19' 1") | 5,670 m (18' 7") |
| J | Max. Depth to 2,500 mm Line | 5,135 m (16' 10") | 5,565 m (18' 3") |
| K | Min. Radius 2,500 mm Line | 1,230 m (4' 0") | 1,250 m (4' 1") |
| L | Min. Digging Reach | -250 m (-1' 2") | -745 m (-3' 7") |
| M | Min. Swing Radius | 2,450 m (8' 0") | 2,500 m (8' 2") |
| d | Bucket Angle | 173° | 173° |

APPROXIMATE WEIGHT OF WORKLOAD MATERIALS

IMPORTANT

Weights are approximations of estimated average volume and mass. Exposure to rain, snow or groundwater; settling or compaction because of overhead weight and chemical or industrial processing or changes because of thermal or chemical transformations could all increase value of weights listed in table.

| Material | Density 1,200 kg/m ³ (2,000 lb/yd ³), or less | Density 1,500 kg/m ³ (2,500 lb/yd ³), or less | Density 1,800 kg/m ³ (3,000 lb/yd ³), or less | Density 2,100 kg/m ³ (3,500 lb/yd ³), or less |
|------------------------------------|---|---|---|---|
| Charcoal | 401 kg/m ³ (695 lb/yd ³) | - | - | - |
| Coke, blast furnace size | 433 kg/m ³ (729 lb/yd ³) | - | - | - |
| Coke, foundry size | 449 kg/m ³ (756 lb/yd ³) | - | - | - |
| Coal, bituminous slack, piled | 801 kg/m ³ (1,350 lb/yd ³) | - | - | - |
| Coal, bituminous r. of m., piled | 881 kg/m ³ (1,485 lb/yd ³) | - | - | - |
| Coal, anthracite | 897 kg/m ³ (1,512 lb/yd ³) | - | - | - |
| Clay, DRY, in broken lumps | 1,009 kg/m ³ (1,701 lb/yd ³) | - | - | - |
| Clay, DAMP, natural bed | - | - | 1,746 kg/m ³ (2,943 lb/yd ³) | - |
| Cement, portland, DRY granular | - | - | 1,506 kg/m ³ (2,583 lb/yd ³) | - |
| Cement, portland, DRY clinkers | - | 1,362 kg/m ³ (2,295 lb/yd ³) | - | - |
| Dolomite, crushed | - | - | 1,522 kg/m ³ (2,565 lb/yd ³) | - |
| Earth, loamy, DRY, loose | - | 1,202 kg/m ³ (2,025 lb/yd ³) | - | - |
| Earth, DRY, packed | - | - | 1,522 kg/m ³ (2,565 lb/yd ³) | - |
| Earth, WET, muddy | - | - | 1,762 kg/m ³ (2,970 lb/yd ³) | - |
| Gypsum, calcined, (heated, powder) | 961 kg/m ³ (1,620 lb/yd ³) | - | - | - |

| Material | Density 1,200 kg/m³ (2,000 lb/yd³), or less | Density 1,500 kg/m³ (2,500 lb/yd³), or less | Density 1,800 kg/m³ (3,000 lb/yd³), or less | Density 2,100 kg/m³ (3,500 lb/yd³), or less |
|--------------------------------|--|--|--|--|
| Gypsum, crushed to 3 inch size | - | - | 1,522 kg/m ³ (2,565 lb/yd ³) | - |
| Gravel, DRY, packed fragments | - | - | - | 1,810 kg/m ³ (3,051 lb/yd ³) |
| Gravel, WET, packed fragments | - | - | - | 1,922 kg/m ³ (3,240 lb/yd ³) |
| Limestone, graded above 2 | - | 1,282 kg/m ³ (2,160 lb/yd ³) | - | - |
| Limestone, graded 1-1/2 or 2 | - | 1,362 kg/m ³ (2,295 lb/yd ³) | - | - |
| Limestone, crushed | - | - | 1,522 kg/m ³ (2,565 lb/yd ³) | - |
| Limestone, fine | - | - | 1,602 kg/m ³ (2,705 lb/yd ³) | - |
| Phosphate, rock | - | 1,282 kg/m ³ (2,160 lb/yd ³) | - | - |
| Salt | 929 kg/m ³ (1,566 lb/yd ³) | - | - | - |
| Snow, light density | 529 kg/m ³ (891 lb/yd ³) | - | - | - |
| Sand, DRY, loose | - | - | 1,522 kg/m ³ (2,565 lb/yd ³) | - |
| Sand, WET, packed | - | - | - | 1,922 kg/m ³ (3,240 lb/yd ³) |
| Shale, broken | - | 1,362 kg/m ³ (2,295 lb/yd ³) | - | - |
| Sulfur, broken | 529 kg/m ³ (891 lb/yd ³) | - | - | - |

Index

Numerics

1,000 Hour / 6 Month Service 4-47
10 Hour / Daily Service 4-15
12,000 Hour / 6 Year Service 4-64
2,000 Hour / Yearly Service 4-57
250 Hour / Monthly Service 4-31
4,000 Hour / Biennial Service 4-63
50 Hour / Weekly Service 4-28
500 Hour / 3 Month Service 4-37

A

Abnormal State Warning Symbols 2-27
Adjust Valve Clearance 4-62
Air Intake System 4-24
 Outer Element of Air Cleaner 4-42
 Replace Outer Air Cleaner Element 4-57
Air-Conditioning Inner Filter 4-53
Alternator and Starter 4-62
Antifreeze Concentration Tables 4-74
Antivibration Shock Mounts 4-62
Ashtray 2-64
Audio Control Panel 2-10
Auto Idle Mode 3-20
Auto Idle Selection 2-46
Auto Idle Selector Button 2-32
Auxiliary Mode Switch 2-9
Avoid High-voltage Cables 1-40

B

Batteries 4-36
Battery 4-68
 Electrolyte Level 4-69
 Terminals 4-69
 Voltage 2-26
Battery Disconnection 1-10
Battery Explosion 1-10
BHL Control Pattern (US Only) 1-13
Boom, Arm and Front Attachment Pins 4-28, 4-31
Boost Mode 3-21
Booster Button 2-17
Booster Cable 3-7
Breaker Operating Precautions 3-34
Breaker Selection 2-46
Bucket 4-66
 O-ring 4-67

Teeth and Side Cutters 4-23
Tooth 4-66

C

Cabin Light 2-54
Cabin Storage Compartments 2-64
Cabin Work Light Switch 2-13
Ceiling Cover 2-60
Change Air Breather Filter 4-47
Charge Warning 2-23
Check and Confirmation After Stopping Engine 3-12
Cigarette Lighter 2-15
Circuit Breaker 2-54
Clock 2-22, 2-37
Cold Weather Hydraulic System Warm-up 3-10
Cold Weather Starting 3-6
Communication
 Error Warning 2-26
 Indicator 2-25
Comparison for Road Liners and Metal Shoes 3-47
Component Locations 2-2
Constant Speed Button 2-14
Control Valve Door 2-67
Coolant and Water for Dilution 4-8
Coolant Temperature Warning 2-23
Cooling System
 Clean Radiator, Oil Cooler and Air Conditioner
 Condenser Coil 4-41
 Engine 4-72
 Engine Coolant Temperature Warning 2-23
 Oil Cooler Dust Net 4-22
 Radiator Coolant 4-58
 Refill Cooling System 4-22
Cracks and Faulty Welds 4-25
Crush Hazard 1-11
Cup Holder 2-65
Cycle Time Tests 4-62

D

Description of Lubrication and Service Chart 4-11
Digital Clock 2-22
Display Selection 2-36
Display Selector Button 2-34
Door Side Latch 2-63
Down Arrow Button 2-34

Dozer Lever 2-18

E

EC Declaration of Conformity 0-1

Economic Mode Selector Button 2-31

Economy Mode Selection 2-45

Electric Welding Attention 1-17

Electrical System 4-68

Emergency Exit 1-12

Engine

Adjust Valve Clearance 4-62

Check and Adjust Engine 4-56

Check Warning 2-24

Coolant Temperature Gauge 2-21

Coolant Temperature Warning 2-23

Cover 2-67

Emergency Stop Switch 2-10

Fan Belt 4-33, 4-34

Head Bolt Torques 4-62

Oil and Filter 4-38

Oil Level 4-16

Oil Pressure Warning 2-23

Speed 2-26

Speed Control Dial 2-9

Start 3-4

Start and Stop 3-2

Stopping 3-11

Entanglement in Rotating Parts 1-9

ESC Button 2-36

Excavator Rated Lift Capacity Tables 1-58

F

Fall Hazard 1-12

Falling Object (Optional) 1-15

Fan Belt 4-30

Filter / Oil Info 2-38

Filter State 2-27

Flow Control 2-43

Flow Control Button 2-32

Flying Debris or Objects 1-11

Front

Bottom Window 2-62

End Attachments 4-36

Hydraulic Pump Pressure 2-27

Upper Windows 2-61

Windows 2-61

Fuel

Gauge 2-20

Heater Switch 2-18

Level 4-19

Main Fuel Filter 4-45

System 4-45

Transfer Pump 4-75

Tank Drain Valve 4-30

Transfer Pump 4-75

Fuse

Boxes 2-55, 4-70

Fuses 4-70

Fusible Link 2-55

Identification 4-71

G

Gauges

Engine Coolant Temperature Gauge 2-21

Fuel Gauge 2-20

Hour Meter 2-22

Hydraulic Oil Temperature 2-21

Multifunction Gauge 2-22, 2-25

General Hazard 1-8

General Venting 4-82

H

Handling a New Excavator 3-1

Handling of Accumulator 4-78

Hanger 2-65, 2-66

Head Bolt Torques 4-62

Heater and Air Conditioner 2-48

Additional Operating Instruction 2-52

Control Panel 2-13, 2-49

Filter 4-39, 4-52

Location of Controls and Vents 2-48

Memory Function of Used Mode 2-52

Refrigerant 4-54

System 4-65

Home Button 2-35

Horn Button 2-16

Hose Clamps 4-36

Hot Pressurized Fluid 1-9

Hot Surface 1-12

Hour Meter 2-22

Hydraulic Attachments (Optional) 3-33

Hydraulic Breaker (Optional) 1-17

Hydraulic Oil Check (Optional) 1-16

Hydraulic System

Flow Control 2-43

Front Hydraulic Pump Pressure 2-27

General Venting 4-82

Hydraulic Breaker

Hydraulic Hoses and Tubing 3-33

Oil and Filter 3-37

Selection 3-33

Hydraulic Cylinders 4-81

Hydraulic Oil Exchange 4-60

Hydraulic Oil Return Filter 4-36, 4-48

Hydraulic Oil Tank 4-17

Hydraulic Oil Temperature Gauge 2-21

Leaks in the Hydraulic System 4-18

Main System Pump 4-81

Oil Exchange 4-60
Rear Hydraulic Pump Pressure 2-27
Swing Motor 4-82
Warm-up 3-9

I

Impact Hazard (Optional) 1-13
Indicator
 Communication Indicator 2-25
Indicator Lights
 Charge Warning 2-23
 Coolant Temperature Warning 2-23
 Engine Check Warning 2-24
 Engine Oil Pressure Warning 2-23
 Preheating Indicator 2-24
 Warning Light 2-24
 Work Light 2-24
Information and Location for Safety Decals 1-6
Inspecting Engine Before Starting 3-2
Instrument Panel 2-17, 2-19
Intermittent Speed Button 2-14
ISO Control Pattern 1-13

K

Keep Bystanders Away 1-9

L

Language 2-37
Leaks in the Fuel System 4-19
Leaks in the Hydraulic System 4-18
Levers
 Adjusting Reclining 2-57
 Adjusting the Seat Forward 2-56
 Adjusting the Seat's Angle 2-56
 Angle Adjustment of Armrest 2-57
 Dozer Lever 2-18
 Safety Lever 2-18
 Travel Lever 2-17
Lift/Tie down (Optional) 1-17
Lifting Machine 5-6
Lifting Objects 3-41
light Switch 2-12
Lights
 Cabin 2-54
Loading and Unloading 5-1
Long Life Operation 3-49
Long Term Storage 4-83
Lubrication and filters 3-2
Lubrication and Service Chart 4-10

M

Magnetic Clutch 4-65
Main Menu 2-33

Maintenance in Special Conditions 4-84
Maintenance Intervals 4-13
Miscellaneous Access Doors 2-67
Mode Selection 3-19
Mode Selector Buttons 2-31
Multifunction Gauge 2-22, 2-25

N

Nuts and Bolts 4-36

O

Oil Cooler Dust Net 4-22
Oil Level of Travel Reducer 4-46
Opening the Window 2-61
Operating
 Instructions 3-19
 Precautions 3-26
Operation 3-1
Operation In
 Extreme Cold 3-43
 Extreme Heat 3-44
 High Altitudes 3-46
 Rainy or Humid Conditions 3-46
 Salt Water Areas 3-46
Operation of All Switches 4-25
Operation Selection Display 2-45
Operation Under Unusual Conditions 3-43
Operational Checks Before Starting Engine 3-3
Operational Controls and Panels 2-6
Operator's Area 2-4
Operator's Compartment Light 2-54
Other Signal Words 1-3
Outer Air Cleaner Element 4-57
Outer Element of Air Cleaner 4-42
Overall Dimensions 6-2
Overload Warning Switch (Optional) 2-18

P

Panels
 Air Conditioner Control Panel 2-13
 Audio Control 2-10
 Heater and Air Conditioner 2-48
 Heater and Air Conditioner Control Panel 2-49
 Instrument 2-17
 Instrument Panel 2-19
 Wiper Switch Panel 2-14
Parking Excavator 3-31
Password
 Activated 2-20
 Set Password 2-41
Password Activated 2-20
Pilot Cutoff Switch 2-54
Pilot Filter 4-36, 4-49
Pins and Bushings 4-36

- Power Boost Selection 2-46
- Power Mode 3-19
- Power Mode Selection 2-45
- Power Mode Selector Button 2-31
- Power Socket 2-15
- Preheating Light 2-24
- Preliminary Work Machine Setup for Maintenance 4-4
- Pressurized Gas and Fluid 1-11
- Preventive Maintenance 4-1
- Pump Pressure
 - Front Pump 2-27
 - Rear Pump 2-27

Q

- Quick Coupler Operation Selection (Optional) 2-47
- Quick Coupler Switch (Optional) 2-9

R

- Radiator Coolant 4-58
- Rear Hydraulic Pump Pressure 2-27
- Refill Cooling System 4-22
- Road Liners (Machine equipped with road liner) 3-47
- Road Liners Information 3-47
- Roll Over Protective Structure (ROPS) 1-41
- ROPS Certification 1-41
- ROPS Warning (Optional) 1-14
- Rotating Buttons 2-16
- Rotating Fan 1-10

S

- Safety Decals 1-4
- Safety Decals With Text 1-4
- Safety Decals Without Text (No-Text) 1-5
- Safety Lever 2-18, 3-12
- Safety Precautions 4-3
- Seat 2-56
- Seat Adjustment
 - Adjusting Reclining 2-57
 - Adjusting the Seat Forward 2-56
 - Adjusting the Seat's Angle 2-56
 - Adjustment of Lumbar Support 2-57
 - Air Suspension Seat 2-59
 - Angle Adjustment of Armrest 2-57
 - Headrest 2-57
 - Left and Right Control Stand Location 2-59
- Seat Belt 1-35, 2-58, 4-24
- Seat Warmer Switch (Optional) 2-15
- Selection Button 2-34
- Selection of
 - Breaker 2-45, 2-46
 - Overload Alarm 2-46
 - Power Boost Selection 2-45

- Quick Coupler Operation 2-47
 - Shear 2-45, 2-46
- Serial Numbers 4-3
- Set Password 2-41
- Setting Clock 2-37
- Shear Buttons 2-17
- Shear Selection 2-46
- Shutdown
 - Check and Confirmation After Stopping Engine 3-12
 - Engine Shutdown 3-11
 - Parking Excavator 3-31
- Side Door 2-67
- Specification 6-1
- Standard Mode Selection 2-45
- Standard Specification 6-1
- Starter Switch 2-8
- Starting Engine Using a Booster Battery 3-7
- Start-up
 - Cold Weather Hydraulic System Warm-up 3-10
 - Cold Weather Starting 3-6
 - Engine Start 3-4
 - Hydraulic System Warm-up 3-9
 - Inspection Before Starting Engine 3-2
 - Operational Checks Before Starting Engine 3-3
 - Starting Engine Using a Booster Battery 3-7
- Stereo 2-53
 - Audio Control Panel 2-10
- Structural Damage 4-62
- Suction Strainer 4-60
- Sun Visor 2-65
- Swing
 - Bearing 4-29
 - Gear and Pinion 4-37
 - Motor 4-82
 - Reduction Device 4-21, 4-46, 4-47, 4-51
- Switches
 - Auto Idle Selector Button 2-32
 - Automatic Travel Speed Control 3-14
 - Auxiliary Mode 2-9
 - Booster Button 2-17
 - Cabin Work Light Switch 2-13
 - Cigar Lighter 2-15
 - Constant Speed Button 2-14
 - Display Selector Button 2-34
 - Down Arrow Button 2-34
 - Economic Mode Selector Button 2-31
 - Engine Emergency Stop 2-10
 - Engine Speed Control 3-19
 - Engine Speed Control Dial 2-9
 - ESC Button 2-36
 - Flow Control Button 2-32
 - Fuel Heater 2-18
 - Home Button 2-35
 - Horn Button 2-16

- Intermittent Speed Button 2-14
- light Switch 2-12
- Overload Warning (Optional) 2-18
- Pilot Cutoff Switch 2-54
- Power Mode Selector Button 2-31
- Power Socket 2-15
- Quick Coupler (Optional) 2-9
- Rotating Buttons 2-16
- Seat Warmer (Optional) 2-15
- Selection Button 2-34
- Shear Buttons 2-17
- Starter Switch 2-8
- Travel Speed Selector Switch 2-11
- Travel/Swing Alarm (Optional) 2-16
- Up Arrow Button 2-33
- Warning Light Switch 2-13
- Washer Button 2-14

Symbols

- Air Cleaner Clogged Warning 2-29
- Hydraulic Oil Overheat Warning 2-28
- Return Filter Clogged Warning 2-29

T

- Table of Recommended Lubricants 4-6
- Tie down (Optional) 1-17
- Towing Procedure 3-32
- Track Assemblies 4-30
- Track Tension 4-79
- Transportation 5-1
- Travel 3-13
 - Control Lever Operation 3-15
 - Instructions 3-16
 - Reduction Device 4-46, 4-50
 - Speed Selector Switch 2-11
- Travel Lever 2-17
- Travel/Swing Alarm Switch (Optional) 2-16

U

- Ultra Low Sulfur Diesel Fuel (Optional) 1-14
- Unloading and Loading 5-1
- Up Arrow Button 2-33
- Using Road Liners 3-48

V

- Venting and Priming Hydraulic System 4-81
 - General Venting 4-82
 - Hydraulic Cylinders 4-81
 - Main System Pump 4-81
 - Swing Motor 4-82
- Visibility Information 1-19

W

- Warning Light 2-24
- Warning Light Switch 2-13
- Warning Tag - "Do Not Operate" 1-9
- Warranty for Road Liners 3-47
- Washer Button 2-14
- Water Separator & Pre Fuel Filter (Fuel Prefilter) and Drain Water As Required 4-20
- Weight of Workload Materials 6-8
- Welding Repairs 1-48
- Window Washer Liquid 4-23
- Windows
 - Front 2-61
 - Front Bottom 2-62
 - Front Upper 2-61
 - Opening 2-61
 - Sun Visor 2-65
- Wiper Switch Panel 2-14
- Work Levers (Joysticks) (ISO Pattern) 3-22
- Work Light Indicator 2-24
- Working Range 6-4

DOOSAN[®]



WARNING: Cancer and Reproductive Harm.

For more information go to www.P65 warnings.ca.gov.



WARNING: Breathing diesel engine exhaust exposes you to chemicals known to the State of California to cause cancer and birth defects or other reproductive harm.

- Always start and operate the engine in a well-ventilated area.
- If in an enclosed area, vent the exhaust to the outside.
- Do not modify or tamper with the exhaust system.
- Do not idle the engine except as necessary.

For more information go to www.P65 warnings.ca.gov/diesel.

Doosan Infracore North America

2905 Shawnee Industrial Way
Suite 100
Suwanee, GA 30024