



# OZip-DC/DC Converter Software

Oztek Intelligent Power Module

## Features

- Bi-directional Buck/Boost Topology
- Low Ripple Interleaved Implementation
- Current or Voltage Control Modes
- Pre-charge Control
- CAN or Modbus RS-485 Interface
- Easy Setup via Serial Port with PC based GUI

## Description

The DC/DC Software application is designed for use with Oztek's OZip family of Intelligent Power Modules. Intended for OEM applications, the OZip based DC/DC converter provides high performance and efficiency in an off the shelf solution.

The Interleaved Buck/Boost converter is a bi-directional DC to DC converter topology that can be used to convert either a low DC voltage to a higher DC voltage, or vice a versa.

By interleaving three converter legs with their modulators offset by  $120^\circ$ , the ripple current, and hence ripple voltage seen on the output is significantly reduced, due to the cancellation between phases. The bi-directional capability of the converter allows it to both source and sink current while regulating the output voltage.

The converter is fully configurable through a CAN or Modbus RS-485 serial interface using the supplied Power Studio™ configuration tool.

The OZip-DC/DC Converter leverages Oztek's 15+ years of experience providing digital power solutions to demanding OEMs, and will accelerate your time to market while reducing development cost and risk.

Compact and rugged, the IP55 rated modules have been qualified for high reliability and long life in the most demanding applications. Multiple air and liquid cooled configurations are available to satisfy a wide range of application requirements. Visit [oztekkorp.com](http://oztekkorp.com) for more info.

Innovative Thinking for Power Control

## Typical Applications

### PV/Battery Based Grid Tie Systems

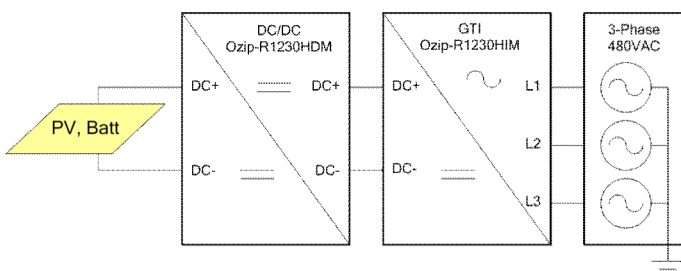

### High Speed Turbo-Generators

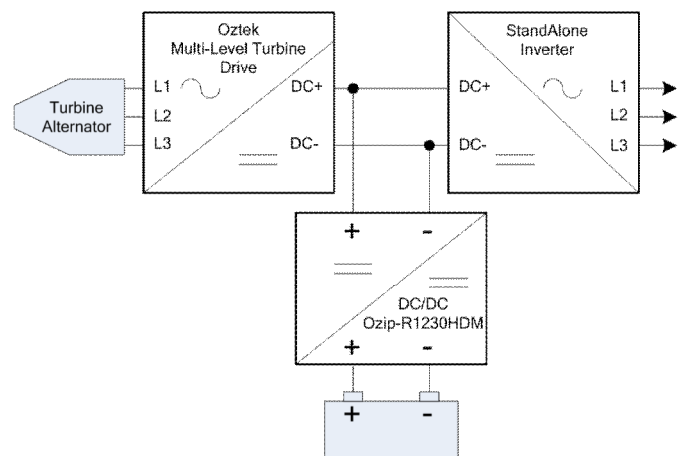

# OZip-DC/DC Converter Software

## System Implementation

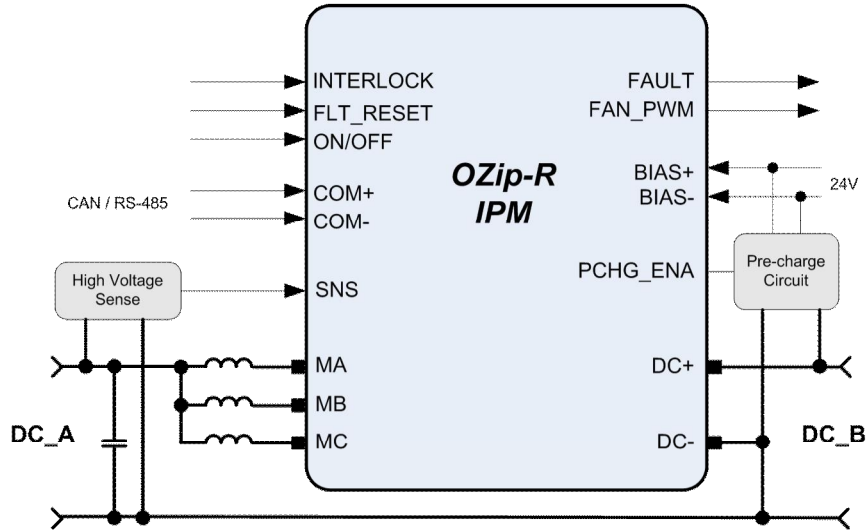

## Power Studio™

Power Studio™ is a Windows based GUI that can be used to easily configure and control the OZip DC/DC Converter. The tool communicates with the converter over the CAN or RS-485 serial port and provides a simple, intuitive user interface. Features include:

- Simple Tabbed Interface
  - ◆ Dashboard
  - ◆ Configuration
  - ◆ Instrumentation
- Converter Configuration
  - ◆ Edit Configurations
  - ◆ Download/Upload Configurations
  - ◆ Archive multiple configuration files
- Dashboard for Control and Monitoring
- Firmware Update Utility

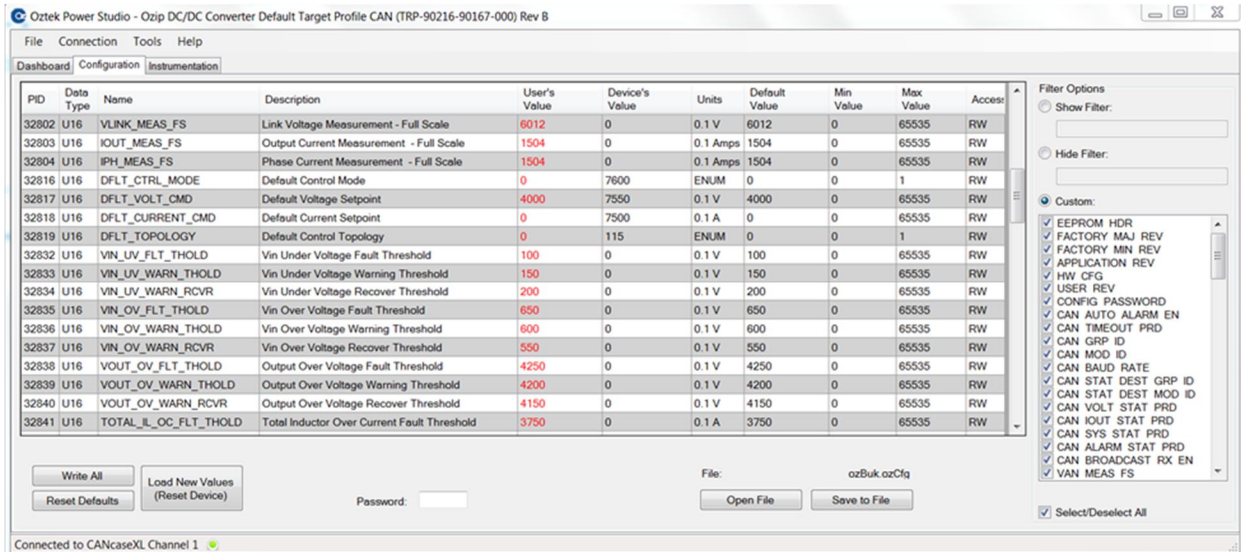

## How To Specify

Typical OZip part number:

OZip-R 12 60 L D C

