

INSOL TECHNICAL DATA SHEET

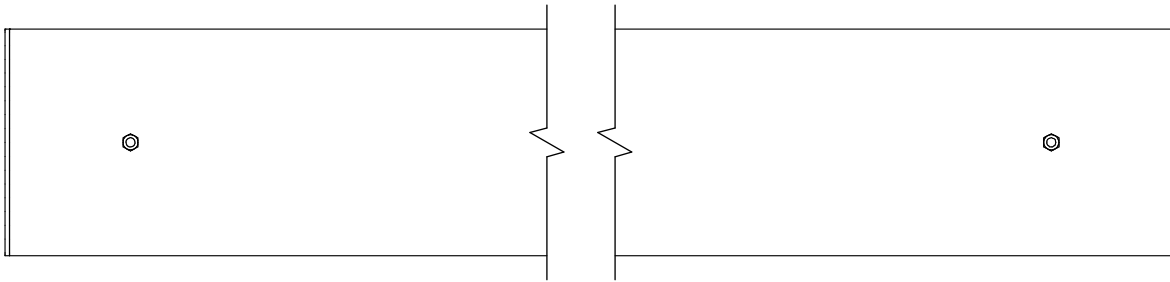

PLAN VIEW

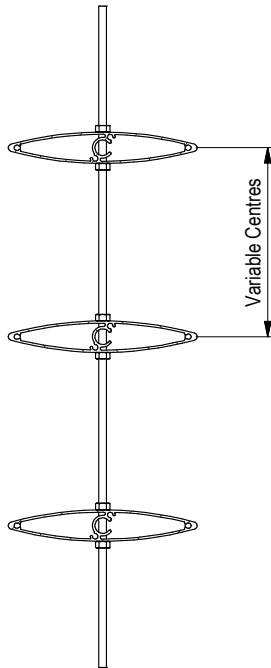

SECTIONED VIEW

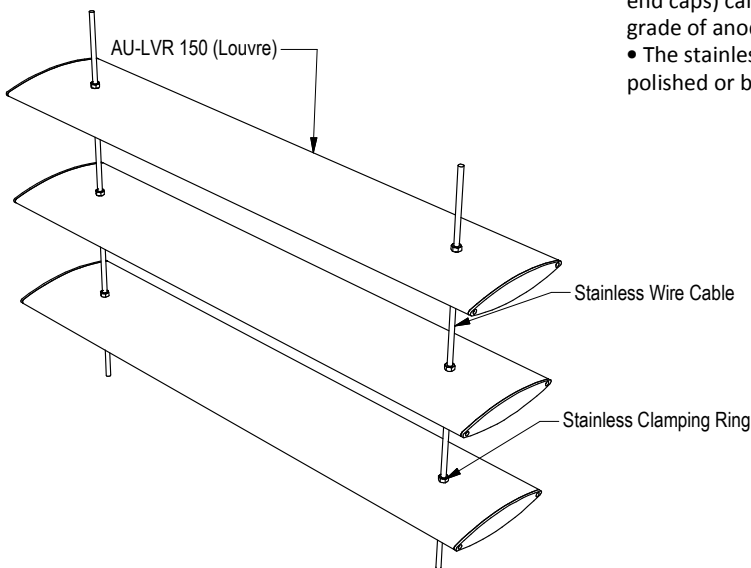

Pictorial

Configuration and layout:

- The louvre blades can be set at any centres.
- No tilt can be set to the blades with this system - blades must be set horizontally.
- Once installed, the louvre blades are fixed in position and cannot be altered.

Assembly and Installation:

- The louvre blades are drilled and threaded on to the stainless cable prior to the fitting of the tensioning fork to the end of the cable.
- Once the stainless cables are fitted to the support structure and tensioned correctly, the louvres are positioned and locked in place with clamping rings on either side of the blade.

Structural Requirements:

- Cables and supports are required at centres appropriate to the wind loading on the louvre blade. See Span Data Table for spans relative to wind zones.
- The stainless cables must be tensioned to a degree that prevents any flex under wind load on the louvre blades. This tension must be calculated on a project specific basis, and the support structure must be engineered to withstand the loading applied.

Componentry and Finishes:

- Insol recommends the use of Ronstan stainless steel cable and components. Technical literature can be obtained from www.ronstanrigging.com
- Contact Insol for advice on the correct cable componentry to use on each specific project.
- All the aluminium components (the louvre blade and end caps) can be finished with any exterior powder coat or grade of anodising.
- The stainless components are typically supplied in a polished or brushed stainless finish.

Not sure if this is the correct fixing detail for your project? Contact Insol to discuss your requirements - we will be able to recommend the most suitable fixing methods for your specific scenario.

**AURORA™ 150
CABLE MOUNTED**



© 2014 All rights reserved
Insol Ltd
Ph: 0800 34 6000
www.insolnz.co.nz

Scale: N.T.S.
Date: 7/03/2014

AU-LVR 150 CM Ver. 1