

INSOL TECHNICAL DATA SHEET

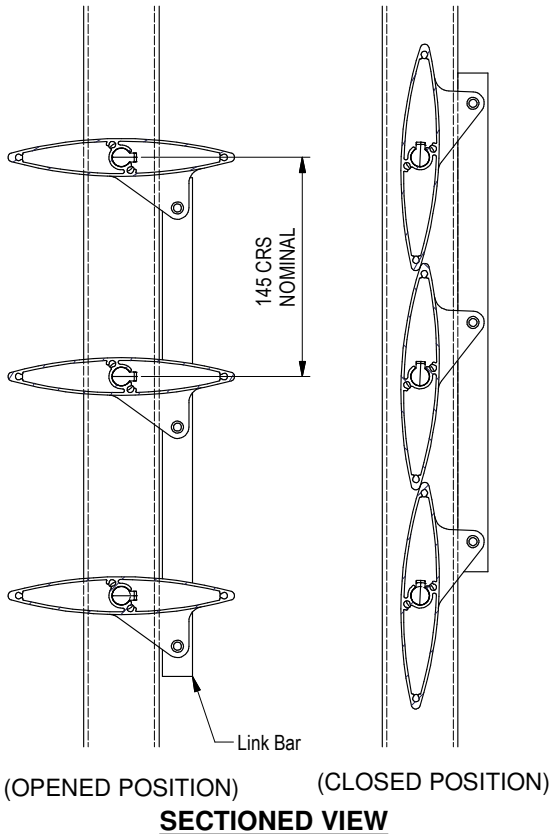
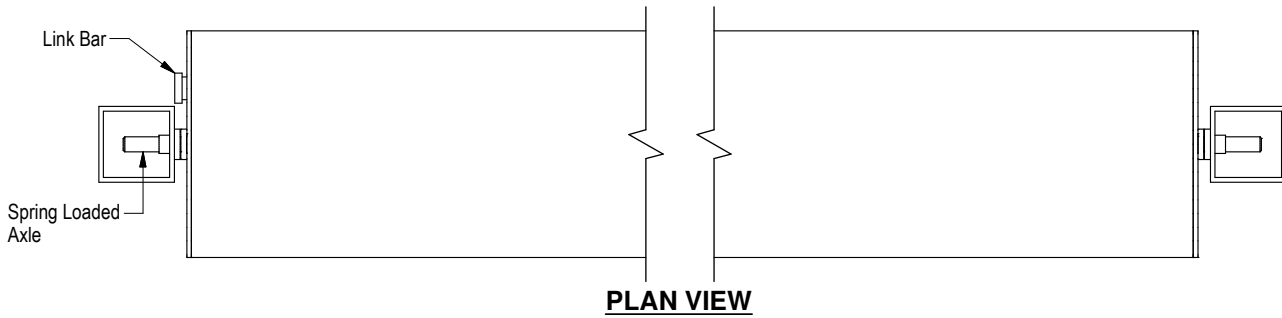

Configuration and layout:

- The louvre blades are set at 145mm centres, giving 5mm overlap between blades.
- Blades can be opened to 115° from the fully closed position.
- All louvre blades in a single panel are connected together with a link bar, and operate simultaneously.

Assembly and Installation:

- The louvre blades are fitted to the aluminium side rails with spring loaded axles. If required, the spring axles can be depressed and the individual louvre blades removed.
- The size of the aluminium side rail can be varied to suit individual project requirements. If required, the box section side rail can be substituted for an aluminium u-channel. Both box section and u-channel must be a minimum of 25mm thick to take the spring loaded axles.

Structural Requirements:

- The length of the louvre blade must be within the span appropriate to the wind loading on the louvre blade. See Span Data Table for spans relative to wind zones.
- The louvre side rail can be fitted to, or incorporated in, a wide range of structures including but not limited to: fixed panels, sliding shutters and fences.
- The fixing detail of the side rail to the main support structure varies dependent on the type of structure. Contact Insol for project specific recommendations.

Componentry and Finishes:

- All the aluminium components (the louvre blade, end caps, link bar and side channel) can be finished with any exterior powder coat or grade of anodising.
- The link bar pivots and spring loaded axles rotate within engineered plastic bushes.
- All fixings and axles are fabricated from stainless steel.

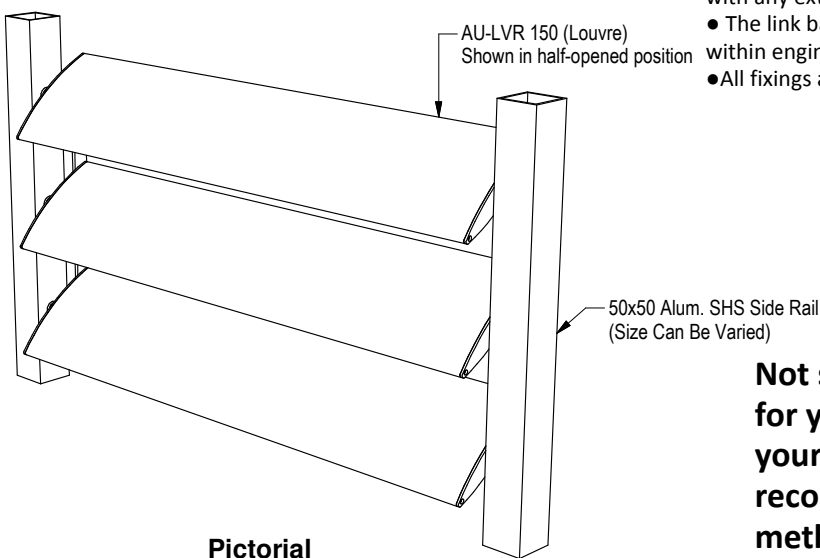

Not sure if this is the correct fixing detail for your project? Contact Insol to discuss your requirements - we will be able to recommend the most suitable fixing methods for your specific scenario.

**AURORA™ 150
MANUALLY OPERABLE**



© 2014 All rights reserved
Insol Ltd
Ph: 0800 34 6000
www.insolnz.co.nz

Scale: N.T.S.
Date: 7/03/2014

AU-LVR 150 MO Ver. 1