

# INSOL TECHNICAL DATA SHEET

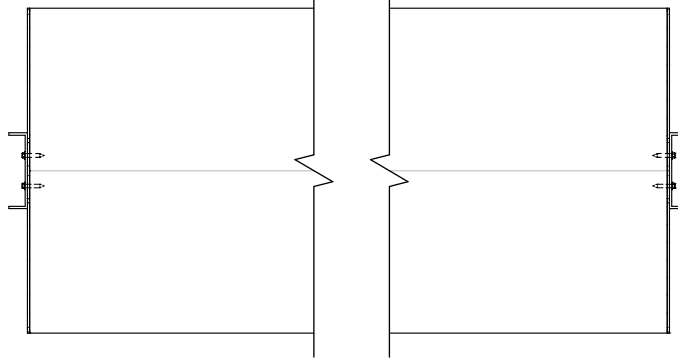

**PLAN VIEW**

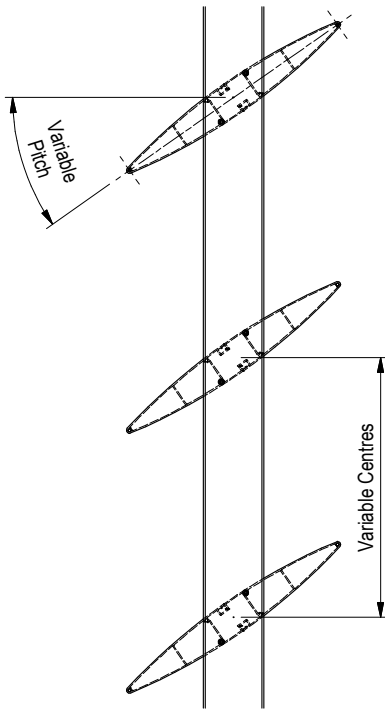

**END FIXING DETAIL**

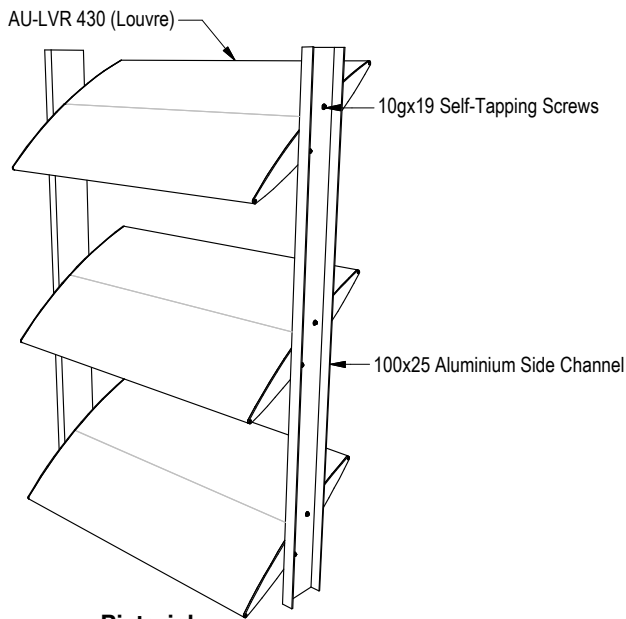

**Pictorial**

**Configuration and layout:**

- The louvre blades can be set at any centres.
- Blade angle can be set at any degree of pitch between completely flat and 90° vertical.
- Once the degree of pitch has been decided upon and the louvres are installed, the angle of the blades is fixed and cannot be changed.

**Assembly and Installation:**

- The louvre blades are fixed to the side channels with stainless 10x19 self-tapping screws.
- The size of the side channel can be varied to suit individual project requirements. If required, the channel can be substituted for an aluminium flat bar, angle or box section.

**Structural Requirements:**

- The length of the louvre blade must be within the span appropriate to the wind loading on the louvre blade. See Span Data Table for spans relative to wind zones.
- The fixing detail of the side channel to the main support structure varies dependent on the type of structure. Contact Insol for project specific recommendations.

**Componentry and Finishes:**

- All the aluminium components (the louvre blade, end caps and side channel) can be finished with any exterior powder coat or grade of anodising.
- Any louvre blades that are too wide to be covered by the side channel are fitted with a 3mm end cap, finished to match the louvre.
- All fixings are stainless steel.

**Not sure if this is the correct fixing detail for your project? Contact Insol to discuss your requirements - we will be able to recommend the most suitable fixing methods for your specific scenario.**

**AURORA™ 430  
END FIXING TO CHANNEL**



© 2014 All rights reserved  
Insol Ltd  
Ph: 0800 34 6000  
www.insolnz.co.nz

Scale: N.T.S.  
Date: 11/03/2014

**AU-LVR 430 EF Ver. 1**