



# Instruction Manual

**Scrubmaster B30 / B30 CL (7715)**

## Introduction

### **Preface**

Dear customer, It is our desire that the good characteristics of the Scrubmaster B30 should justify the confidence you demonstrated by making this purchase. Prior to the first drive, carefully read the chapter "Safety Information" as well, in order to ensure you a safe working with the machine.

Your own safety, as well as the safety of others, depends to a great extent on how the vehicle is moved and operated. Before using the equipment for the first time, read this original manual thoroughly, act according to the information contained and keep it in a safe place for future reference or subsequent owners. The manual provides valuable information about operation, service and maintenance. The warning symbols as used in this manual identifies items relevant to safety. Please observe the safety provisions (see chapter "Safety Information").

Your authorised Hako dealer will be pleased to answer further questions regarding the vehicle or the operation and maintenance manual.

Please be advised explicitly that we cannot accept any legal issues out of the contents of this manual. If repair work has to be performed make sure that only genuine spare parts are used; only genuine spare parts may guarantee a dependable machine. We reserve the right for technical improvement.

Valid as of: April 2014

**Hako GmbH**  
**D-23843 Bad Oldesloe**  
**Hamburger Str. 209-239**  
**Telephon +49 4531 806-0**

### **Proper use**

The machine is a vacuum scrubbing machine for wet cleaning of hard-surfaced floors. This machine is intended for commercial use, for example in hotels, schools, hospitals, factories, shops, offices and rental businesses. Using the machine beyond this scope of application will be deemed improper use; The manufacturer cannot be held liable for consequential damages; the user alone bears the risk.

The term of proper use also includes operation, maintenance and repair work to be performed in compliance with the manufacturer's specifications.

The Scrubmaster B30 may only be operated, serviced and repaired by personnel who are familiar with the work involved and are aware of the risks. The applicable accident prevention laws must be observed and any generally accepted health and safety directives must be maintained.

Based on the conception, design and construction of the model introduced onto the market by us, the machine complies with the applicable basic safety and health requirements stipulated in

## Introduction

the EC directives (refer to the Declaration of Conformity). The EC Declaration of Conformity is no longer considered valid in the event of modifications to the machine not authorized by us. The manufacturer is not deemed liable for any damage resulting from unauthorized modifications to the machine.

### **Notes on warranty**

The terms of the sales contract apply. Damages are not subject to warranty if they are due to non-compliance with the maintenance and service provisions. The maintenance work has to be performed by an authorized Hako service center and confirmed in the "Maintenance certificate" which is the warranty document.

The following is excluded from warranty: fuses, natural wear, damages caused by overload, inexpert handling and unauthorized modification of the machine. Moreover, any claim for warranty cannot be accepted if damages of the machine are caused by fitting parts or accessories without Hako's prior and explicit consent or by non-compliance with the maintenance instructions.

### **Acceptance of the machine**

Upon arrival, check machine for possible damages in transit. Follow unpacking instructions on shipping pallet. Each unit has been tested and thoroughly inspected before shipment. Any damage is the responsibility of the delivery carrier who should be notified immediately.

### **Disposing of the machine**

Render the machine inoperable. It must not represent a source of risks to children. Dispose of the machine in accordance with the applicable local regulations. For further information on disposal and recycling, contact the authorized Hako dealer where you purchased the machine.

Used batteries with the recycling symbol contain reusable commodities. The heavy metals contained simultaneously represent a serious risk to health and to the environment. Never open batteries or damage them. Never touch, inhale or swallow any material inside batteries. Health hazard! Never allow batteries to pollute the environment. Risk of contaminating the ground and water! In accordance with the symbol with the crossed out bin, these batteries must

not be disposed of in domestic waste. The return and recycling of old batteries must be agreed on with your authorized Hako dealer in accordance with the Battery Law § 6 and § 8 (BattG).





<b>Preface</b> . . . . .	<b>2</b>	<b>3</b>	<b>Operation</b> . . . . .	<b>20</b>	5.4.6	Disposing of batteries. . . . .	43
Proper use . . . . .	2	3.1	Method of operation . . . . .	20	5.5	Solution tank . . . . .	44
Notes on warranty . . . . .	3	3.1.1	Brush head . . . . .	20	5.5.1	Filling the solution tank. . . . .	45
Acceptance of the machine . . . . .	3	3.1.2	Solution tank . . . . .	20	5.5.2	Emptying the solution tank . . . . .	45
Disposing of the machine. . . . .	3	3.1.3	Squeegee. . . . .	21	5.5.3	Cleaning the fresh water filter	45
<b>1 Safety information</b> . . . . .	<b>5</b>	3.1.4	Recovery tank . . . . .	21	5.6	Soiled Water tank. . . . .	46
1.1 Safety and Warning Symbols. . . . .	5	3.1.5	Power flow / traction drive . . . . .	21	5.6.1	Empty Soiled Water Tank . . . . .	47
1.2 General Provisions. . . . .	6	3.1.6	Batteries and charger. . . . .	22	5.6.2	Clean Soiled Water Tank . . . . .	47
1.3 Operating information. . . . .	7	3.1.7	Options. . . . .	22	5.6.3	Clean Suction Filter . . . . .	47
1.4 Maintenance information . . . . .	8	3.2	Operating and indicator elements . . . . .	23	5.6.4	Checking the Draining valve seal. . . . .	47
1.5 Particular risks . . . . .	9	3.2.1	Operating panel . . . . .	23	5.6.5	Checking the Tank lid seal . . . . .	47
1.6 Information for Protection of Environment. . . . .	10	3.2.2	Operating elements on the machine . . . . .	31	5.7	Brush head. . . . .	48
1.7 Labels on the machine . . . . .	11	<b>4</b>	<b>Technical Data</b> . . . . .	<b>33</b>	5.7.1	Changing the brushes . . . . .	49
<b>2 First Operation</b> . . . . .	<b>13</b>	<b>5</b>	<b>Maintenance and Service</b> . . . . .	<b>35</b>	5.7.2	Changing the deflector roller . . . . .	49
2.1 Instruction. . . . .	13	5.1	Hako system maintenance. . . . .	35	5.7.3	Changing the sealing strip . . . . .	49
2.2 Initial charging procedure. . . . .	13	5.2	Maintenance Document. . . . .	36	5.8	Squeegee. . . . .	50
2.3 Before Putting into Operation . . . . .	13	5.3	Maintenance Schedule. . . . .	37	5.8.1	Cleaning the squeegee . . . . .	50
2.4 Switching the machine on . . . . .	14	5.4	Battery system . . . . .	41	5.8.2	Changing the sealing strips . . . . .	50
2.5 Operation . . . . .	15	5.4.1	Charging batteries . . . . .	42	5.8.3	Adjusting the sealing strips . . . . .	51
2.5.1 Useful tips . . . . .	16	5.4.2	Charge status indicator . . . . .	42			
2.5.2 Error code table . . . . .	17	5.4.3	Total discharge signal transducer (TSG) . . . . .	43			
2.6 Stopping and switching off the machine . . . . .	18	5.4.4	Servicing the driving batteries . . . . .	43			
2.7 After completing work. . . . .	18	5.4.5	Replacing the batteries . . . . .	43			
2.8 Transportation and lashing points . . . . .	19						
						<b>EC-Declaration of Conformity</b> . . . . .	<b>53</b>

## Safety information

### 1 Safety information

#### 1.1 Safety and Warning Symbols

All paragraphs in this manual referring to your personal safety, the safety of your machine and the environment protection are attributed one of the following warning symbols:

Symbol	Hazardous for...	Description
Safety Provisions 	persons and goods	Safety Provisions in dangerous situation caused by misuse inaccurate adherence of instructions or prescribed work routine.
CAUTION 	the machine	important information on handling the machine in order to maintain operability.
Ecological hazard 	the environment	due to use of substances representing an inherent danger to health of environment

## Safety information

### 1.2 General Provisions

- Apart from the provisions contained in this instruction manual, the general safety provisions and the accident prevention regulations as imposed by law have to be complied with.
- Before taking your machine into operation, carefully read the instruction manual as well as other separate instructions for accessories or attached implements and comply with all points mentioned there during work.
- Persons being trained by qualified Hako technicians only are authorised to operate, service and repair the machine.
- This vehicle is not intended to be used by persons (including children) with limited physical or mental capabilities or persons without sufficient experience and ability.
- You are advised to thoroughly study the safety instructions since precise knowledge only helps avoiding errors during operation of the machine and thus guarantee faultless usage of the machine.
- The operating instructions have to be at hand at the place of use of the machine, and therefore have to be kept readily available at the machine.
- When selling or letting the machine for rent, hand out these documents to the new owner/operator and have the transfer certified!
- The warning and instruction plates attached to the machine contain valuable advice about safe operation. Immediately replace incomplete or illegible labels.
- As far as safety standards are concerned, spare have to equal genuine spare parts!

## Safety information

### 1.3 Operating information

- Before starting the machine up for the first time, the battery to be used must be fully charged, properly, by implementing the initial battery charge routine. Please pay attention to the operating manual provided with the charging unit as well as the manual from the battery manufacturer. Hako assumes no liability for damage to the battery caused by a fault when the battery is charged for the first time.
- Check the operational safety of the machine each time before starting it up! Clear any faults immediately!
- Before starting work, the operator must be fully familiar with all adjustment, operating and control elements as well as their respective function! It is too late to do this when the machine is actually in operation!
- Always wear heavy duty, non-slip footwear when working with the machine.
- The machine may only be driven on and the equipment used on those surfaces which have been approved by the contractor or person appointed by him.
- When using the machine, it is essential to pay attention to third parties, especially children.
- Start driving immediately after switching on the brush head drive otherwise imprints of the brush could be produced on the floor.
- Only use cleaning agents suitable for the vendor (non-foaming) and observe all the use, disposal and warning information provided by the cleaning agent manufacturer.
- Only open empty recovery tanks.
- The machine is not suitable for clearing up hazardous, inflammable or explosive fluids, dust or substances.
- It is forbidden to use the machine in potentially explosive atmospheres.
- To prevent unauthorized use of the machine, remove the key from the main switch (Scrubmaster B30 CL only).
- When transporting the machine, the squeegee and brush head must be raised. The way of driving must be adapted to the local conditions.
- The machine has been conceived for use on level surfaces with a maximum gradient of 2%.

## Safety information

### 1.4 Maintenance information

- Operating personnel must complete the necessary daily and weekly maintenance work. All other maintenance work must be completed at your nearest Hako service center.
- The maintenance work and maintenance intervals prescribed in the operating manual must be adhered to.
- Suitable tools must be used for cleaning and maintenance work.
- The machine must be inspected by a recognized technical expert in respect of operational safety, within the terms of the applicable accident prevention laws, at reasonable intervals (we recommend at least once a year) and following modification or repairs.
- Spare parts must comply with the minimum technical requirements stipulated by the manufacturer! This is ensured by the use of original spare parts.
- Before cleaning and servicing the machine or replacing parts, switch off the motors and main switch (Scrubmaster B30 CL only).
- To prevent unauthorized use of the machine, remove the key from the main switch (Scrubmaster B30 CL only).
- Always disconnect the battery terminal before starting any work on the electrical installation.
- When working in the area of the raised recovery tank, it must be hinged open fully to prevent it being knocked shut or further open and down unintentionally.
- It is not permitted to clean the machine with a pressure washer or steam blaster.
- It is not permitted to use aggressive and corrosive cleaning agents.
- Allow the machine to dry after being cleaned, e.g. over the weekend.
- Only start the machine up when all the safety equipment has been installed and brought to its protecting position.



## Safety information

### 1.5 Particular risks

#### Electronics

- In the case of defects in the electrical installation, switch the vehicle off immediately and clear the fault.
- Work on the electrical equipment may only be carried out by electricians who have received the necessary training and in accordance with the electrical engineering regulations.
- The vehicle's electrical equipment must be inspected/checked at regular intervals. Defects, such as loose connections and cable damage, must be rectified immediately.
- Only use original fuses with the prescribed amperage.

#### Batteries

- Observe the information in the operating manual provided by the battery manufacturer.
- Before charging the batteries, read and take heed of the safety information regarding the charging area/charging station.
- Batteries may only be handled and changed by qualified service person-

nel.

- The unit is set up for running on maintenance-free and sealed batteries. Use maintenance-free batteries only!
- Due to a change in the center of gravity, only batteries approved by Hako may be installed at the intended position.
- Never lay any metallic objects or tools on batteries - risk of short circuit!
- Ensure sufficient ventilation in the charging area when charging the batteries – risk of explosion!
- For further safety information, refer to flyer 88-60-2556 - Information on Driving Batteries.

#### Information on the power plug

- Only take hold of the power plug and power cable when your hands are dry.
- Never insert the power plug in the socket if the base is wet or damp.
- Never immerse the power cable or power plug in water or other fluids clean them in running water. Risk of electric shock!
- Dry any power plugs and power ca-

bles which have become damp with a dry cloth before connecting them in power sockets.

- Pay attention that the power socket is dry.
- We recommended the use of splash-proof power sockets complying with DIN VDE 0620-1.
- Pay attention that no water or fluids can get on to live machine parts. If water should penetrate to such parts, disconnect the power plug immediately and have the vehicle checked at an authorized Hako service center.
- The power connection cable must be inspected for signs of damage at regular intervals. If damage is detected, the cable must be replaced prior to further use.

## Safety information

### 1.6 Information for Protection of Environment

- For safe use of substances inheriting a danger to health and environment specific knowledge is required.
- Observe the legal directives and local regulations for disposal of detergents.
- Used batteries labelled as recyclable contain reusable economic goods. According to the crossed dustbin label these batteries must not be added to the normal waste.

## Safety information

### 1.7 Labels on the machine

The following safety and warning labels are attached to the machine where easily legible.



Missing or illegible labels must be replaced immediately.

Company logo (Fig. 1/1)

Rating plate (Fig. 1/2a)

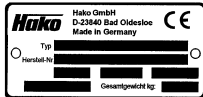

Explosive gases (Fig. 1/2b)

**ACHTUNG:** Explosive Gase – Flammen und Funken vermeiden – Während des Ladens für ausreichende Belüftung sorgen.  
**Caution:** Explosive gases – Avoid fires and sparks – Provide for sufficient ventilation during loading!  
**Précaution:** Gaz explosifs – Éviter des flammes et étincelles – Pourvoir suffisante ventilation pendant chargement!

Yellow Point (parts of maintenance)  
(Fig. 1/3)

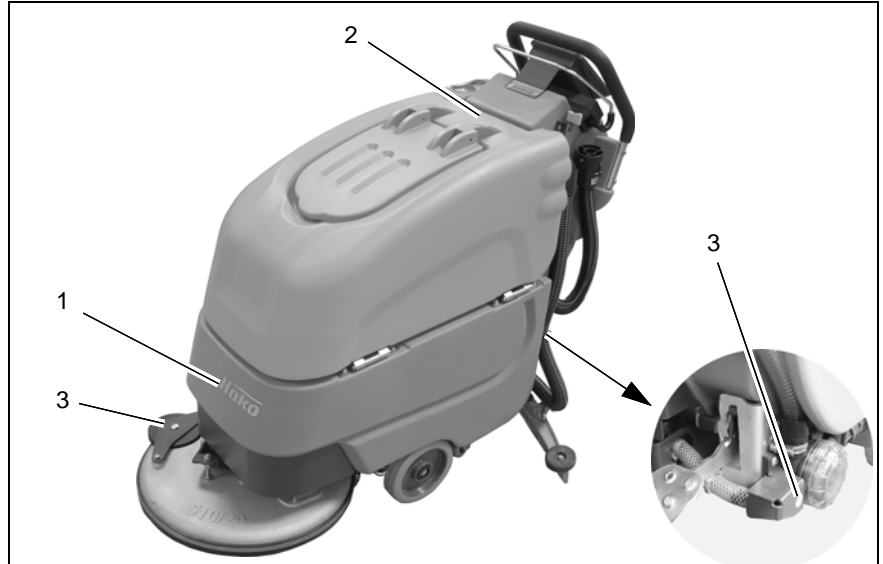

Fig.1

## Safety information

Waste water draining hose (Fig. 2/3)



A = Read and observe the operating manual (Fig. 2/4)

B = Maximum permissible gradient 2% (Fig. 2/4)

C = Do not clean the machine with a pressure washer (Fig. 2/4)



Fig.2

Only maintenance-free batteries (Fig. 2/4)

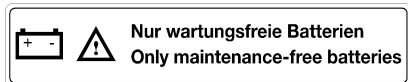

## 2 First Operation

### 2.1 Instruction

Instruction is required before first operation. First instruction into handling of the machine must be held by a qualified person sent by your local Hako contract dealer. Your Hako dealer will be informed by the manufacturer upon delivery of the machine and will contact you to make a date for instruction.

### 2.2 Initial charging procedure



Before first operation of the machine, fully charge the battery with an initial charging procedure and comply with the operating instructions of the charger as well as with those of the battery manufacturer. Hako cannot be held liable for damages resulting from an insufficient initial charge.

### 2.3 Before Putting into Operation

Complete the following inspections before taking the machine into operation:

1. Check the area around the machine for signs of leakage. Hoses, lines and tanks must be free from any leakage or damage.
2. Install brushes and squeegee, see maintenance chapter.
3. Install batteries and connect battery plug, see maintenance chapter.
4. Check battery charge and proceed to re-charging of batteries if required. Generally proceed to initial charging before first operation of the machine.
5. Empty recovery tank and clean it if required, see maintenance chapter.
6. Refill solution tank and add cleaning agent according to the manufacturer's recommendations.



Use only cleaning agents suitable for automatic machines (low-foaming) and comply with the instructions for use, disposal and with the warning information specified by the cleaning agent's manufacturer.

## First Operation

### 2.4 Switching the machine on



Before switching the machine on, please read the safety information in Chapter 1.

Carry out the following preliminary work so that the machine is ready to operate:

- If necessary, disconnect the power plug of the charging device from the socket and place it in the holder. If the power plug is not inserted properly in the holder (Fig. 3/1), the machine is not ready to operate!



Fig.3

- Switch the machine on by actuating the switch (Fig. 4/1) from position (0) to position (1).

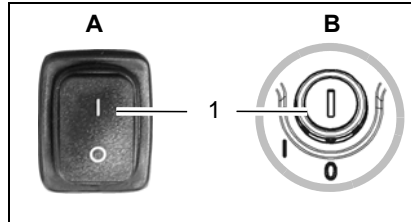

Fig.4

# First Operation

## 2.5 Operation

### Scrubmaster B30

1. Switch the machine on at the main switch. The suction turbine is switched on.
2. Lower the squeegee using the squeegee lever.
3. Lower the brush head using the foot pedal.
4. Draw back the bar on the bail system. The brush head drive and solution supply are switched on.
5. Set the solution quantity with the hand valve.
6. Push the machine. The power flow of the brush head drive supports the forward drive.



Start driving immediately after switching on the brush head drive otherwise imprints of the brush could be produced on the floor. Raise the brush head when driving over thresholds.

### Scrubmaster B30 CL

1. Switch the machine on using the key switch. All the units are in Standby
2. Lower the squeegee using the squeegee lever. The suction turbine is switched on.
3. Lower the brush head using the foot pedal.
4. Pull the dead-man's switch on the bail system. The brush head drive is switched on.
5. Set the solution quantity using the button on the operating panel.
6. Set the driving direction and speed using the bail system.
7. To alter the cleaning intensity of the cleaning process, use the buttons on the operating panel to change the solution quantity and switch the solution supply on and off.



Start driving immediately after switching on the brush head drive otherwise imprints of the brush could be produced on the floor. Raise the brush head when driving over thresholds.

## First Operation

### 2.5.1 Useful tips

Before beginning wet cleaning, sweep the floor. This not only improves the cleaning effect but also reduces the machine's liability to wear.

The floor should be treated twice in the case of particularly dirty floors or to remove wax (thorough cleaning). During the first cleaning process, the floor is scrubbed with a cleaning agent dosage appropriate to the degree of soiling, whereby the squeegee is raised.

The cleaning agent is left to act on the floor for approx. 5 to 10 minutes according to the manufacturer's instructions, then scrub the floor again and, after that, treat it with the squeegee lowered.

Important information: pay attention to the correct dosage of the cleaning agent. The correct dosage helps to reduce costs and protect the environment. The development of excessive foam impairs the machine's function. It indicates there is too much cleaning agent or the wrong one has been selected for the cleaning process being completed. Unused component parts of a cleaning agent which end up in the waste water lead to the development of

foam. Information on dosage is provided on the cleaning agent container. Use the manufacturer's information as an initial basis. Practical experience will ensure that you quickly find out which is the right Hako cleaning agent and the optimum dosage to suit your needs.



## First Operation

### 2.5.2 Error code table

In addition to the Service indicator (wrench), a four-digit service code appears in the indicator field. The dots in the service code flash. Clear the fault or note down the service code and inform your authorized Hako dealer.

<b>Error</b>	<b>Cause</b>	<b>Remedy</b>
1.2.5.2.	Brush motor overload	Let the brush motor cool down
1.2.6.1.	Brush is blocked	Remove foreign bodies
1.2.6.5.	Brush semiconductor	Allow the machine to cool down or inform Hako service
1.2.6.6.	Brush is not installed	Install the brush
1.4.2.1.	Suction turbine semiconductor	Allow the machine to cool down or inform Hako service
3.2.1.1.	Invalid TSG setting	Inform Hako service
4.6.1.2.	Internal SE error	Inform Hako service

## First Operation

### 2.6 Stopping and switching off the machine

#### Scrubmaster B30

1. Stop the drive and release the safety switch:
  - The brush drive and solution supply are switched off
2. Raise the brush head.
3. Raise the squeegee.
4. Switch off the machine with the main switch.

#### Scrubmaster B30 CL

1. Release the safety switch:
  - The traction drive, brush drive and solution supply are switched off.
2. Raise the brush head.
3. Raise the squeegee.
  - The suction turbine continues to run approx. 10 seconds.
4. Switch off the machine with the key switch.
5. The machine must be protected and secured against being started up accidentally and uncontrolled movements.

### 2.7 After completing work

1. Drive to an appropriate maintenance area.
2. Stop the machine and switch it off.
3. Empty the recovery tank and flush it.



Observe the applicable laws and local regulations when disposing of cleaning agents.

4. Check the solution filter.
5. Check the sealing strips and suction hose.
6. Check the electrical equipment, functions and settings.
7. Clean the machine.
8. Charge the batteries.

If the machine is to be shutdown for a longer period, the solution tank must be emptied.



It is not permitted to clean the machine with a pressure washer or steam blaster.

## First Operation

### 2.8 Transportation and lashing points

When running the machine to the site of use, the squeegee and brush head must be raised.

When the machine is to be transported on another vehicle or trailer, it must be secured against rolling away. Lash the machine down securely. To do this, it must be secured at the front (on both sides) and rear at the hold points (Fig. 5/1).

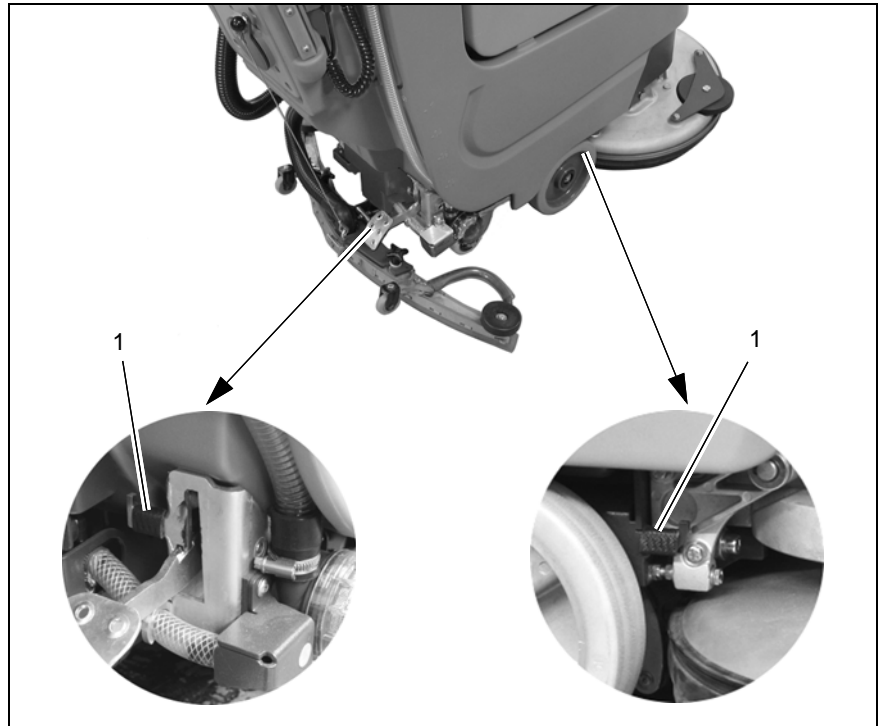

Fig.5

Scrubmaster B30

### 3 Operation

#### 3.1 Method of operation

##### General information

The Scrubmaster B30 is a scrubber dryer for the wet cleaning of hard floors.

##### 3.1.1 Brush head

The brush in the brush head (Fig. 6/1) is driven by an electric motor. The brush head is lowered by means of the brush pedal. The floor is cleaned by the rotary brush and cleaning agent. The brush can be removed for maintenance purposes by pressing a button.

##### 3.1.2 Solution tank

The solution tank (Fig. 6/2) is filled through a detachable filling neck. The Scrubmaster B30 solution tank has a volume of approx. 30 liters. The fill level can be seen through a transparent hose. The cleaning agent quantity can be regulated.

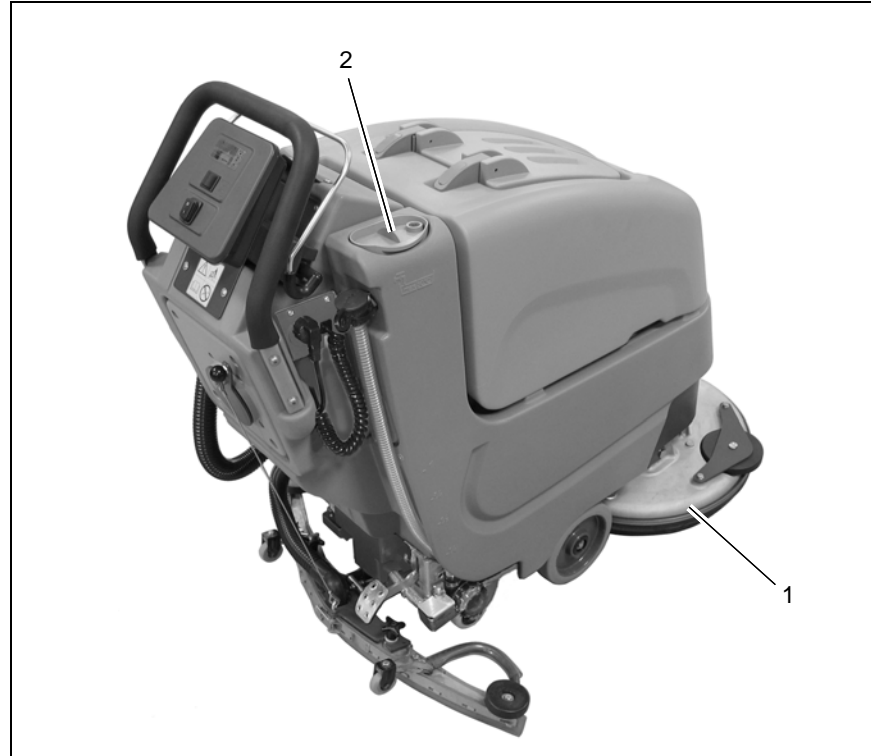

Fig.6

Scrubmaster B30

## Operation

### 3.1.3 Squeegee

The squeegee (Fig. 7/1), which is hooked in and can move, is lowered by means of a hand lever and adapts perfectly to the floor through the sealing strips. The suction turbine vacuums up the waste water from the floor.

### 3.1.4 Recovery tank

The waste water which is vacuumed up is fed from the squeegee to the recovery tank (Fig. 7/2) via a suction hose. A hand-held suction hose is available as an option to clean and vacuum up solution from inaccessible areas.

### 3.1.5 Power flow / traction drive

The hand-guided Scrubmaster B30 is optimally supported by the power flow of the brush drive. The Scrubmaster B30 CL is provided with a continuously adjustable traction drive. The driving speed, driving direction and dynamic deceleration are controlled by the electronic drive control.



Fig.7

Scrubmaster B30

## Operation

### 3.1.6 Batteries and charger

The machine is equipped with maintenance-free batteries (Fig. 8/1), a fully automatic battery charger (Fig. 8/2) and a total discharge signal transducer (TSG) to protect it against total discharge. Pay attention here to the safety information. For information on driving batteries, refer to supplementary sheet 88-60-2556

### 3.1.7 Options

- Hand suction tool incl. cleaning tools (7036.40)
- Dosing system (7056.02)
- Floating unit (7743)

Scrubmaster B30 only:

- Onboard dosing system (7678)

Scrubmaster B30 CL only:

- Onboard dosing system (7678.05)
- Tool connection (7724)



Please refer to our spare parts catalogue in Internet under [www.hako.com](http://www.hako.com) for information on accessories such as brushes, rollers, pads, drive plates with centerlock and suction lips.

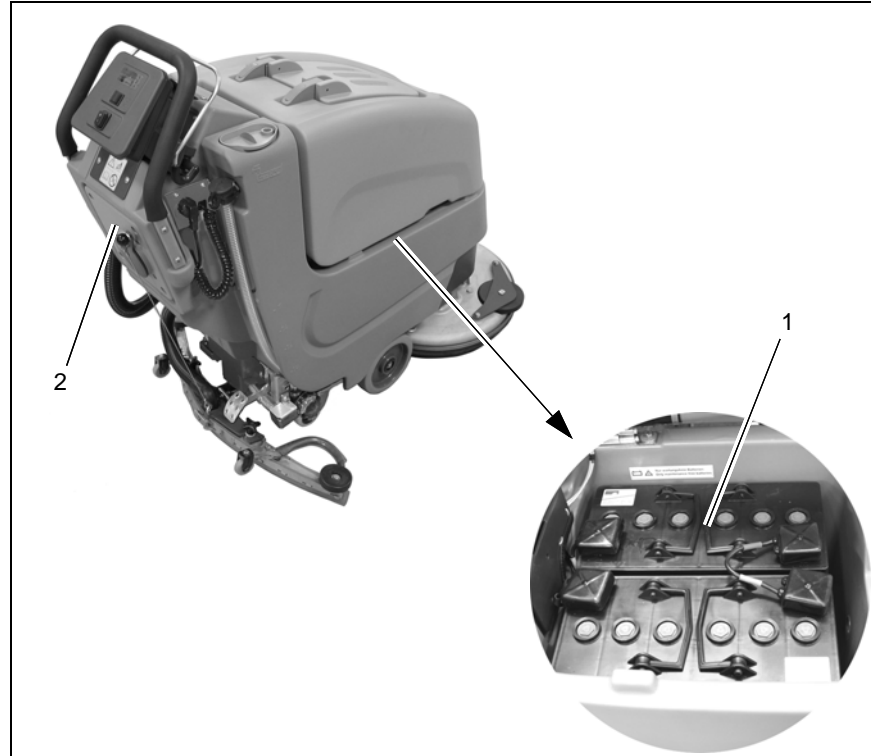

Fig.8

Scrubmaster B30

## Operation

### 3.2 Operating and indicator elements

#### 3.2.1 Operating panel Scrubmaster B30

- 1 Indicator field for:
  - operating hour counter,
  - service indicator, and
  - charge status indicator
- 2 Charge mode indicator
- 3 Main switch
- 4 Bail system switch
- 5 Brush ejector

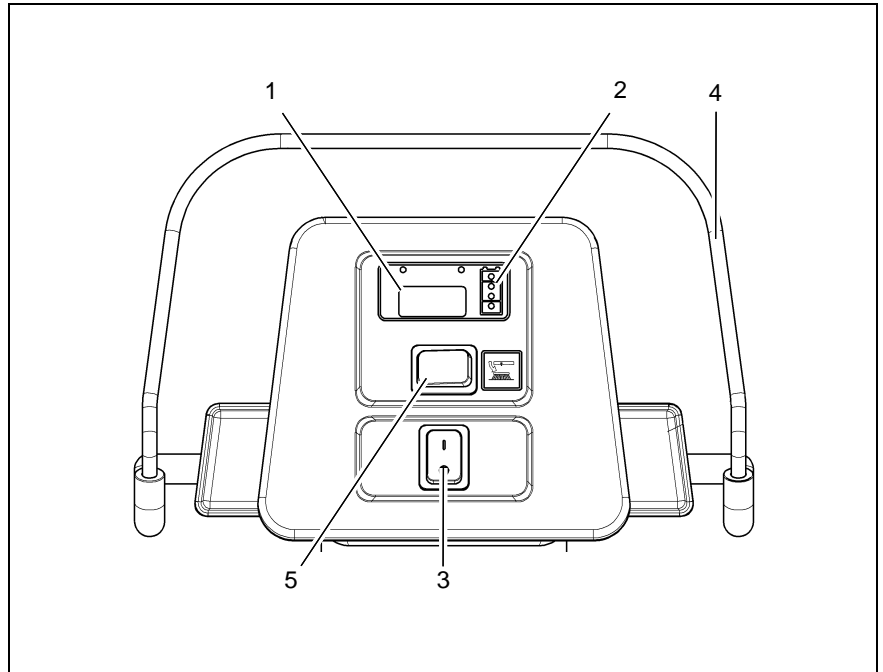
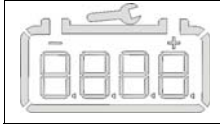

Fig.9

Scrubmaster B30

## Operation



### Indicator field (Fig. 9/1)

The indicator field provides a central function monitoring facility and indicates all operating states.

### Operating hour counter

After switching on, the software version, last service code and current number of operating hours appear briefly in the indicator field. Then the charge status is indicated.

### Service indicator

The service indicator lights up when an error has occurred in the system and the cleaning or driving process is interrupted. In addition to the service indicator (wrench), a four-digit service code appears in the indicator field. The dots in the service code flash.

Clear the fault or note down the service code and inform your authorized Hako dealer.

### Charge status indicator

After switching on, the indicator field displays the charge status indicator. The four icons indicate the current battery charge status during operation.

4 icons: charge level 100%-60%

3 icons: charge level 60%-40%

2 icons: charge level 40%-20%

1 icon: charge level less than 20%

Battery icon flashes = three minutes until

OFF.

Charge the batteries, refer to section 5.4



## Operation

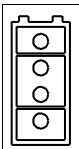

### Charge mode indicator (Fig. 9/2)

Four green LEDs indicate the charge mode with reference to the current charging stage. If the battery is discharged, the two bottom LEDs light up. While charging, the other LEDs light up one by one.

The number of LEDs lit up corresponds to the following charge status:

1 LED:

Soft start, battery pre-charge cycle

2 LEDs

Main charge cycle - battery is being charged

3 LEDs

Trickle charge - charge level 80%

4 LEDs

Charge cycle complete - charge level 100%. Charge retention is enabled



Flashing of the bottommost LED is indicative of a fault. See charger manual.



Hako chargers are designed to work continuously, i.e., at the end of the charge cycle, the charger automatically enables charge retention to ensure that the battery is always perfectly charged. To get the most from your battery and optimize its service life, it is best to always fully charge the battery (four LEDs on).



### Main switch (Fig. 9/3)

The main switch is used to switch the electrical system on and off.

### Bail system switch (Fig. 9/4)

Letting go of the bail system switch during operation stops the brush head drive and the solution supply. The suction turbine remains switched on. Pulling up the bail system switch enables the brush head drive's power flow effect to support the machine drive.

### Brush ejection button (Fig. 9/5)

Press the brush ejection button to eject the brush for maintenance purposes, see paragraph 0.1.1

## Operation

### Scrubmaster B30 CL

- 1 Indicator field for:
  - operating hour counter,
  - service indicator, and
  - charge status indicator
- 2 Charge mode indicator
- 3 Main switch
- 4 Bail system switch
- 5 Direction switch
- 6 Driving speed control
- 7 Symbol for silence kit
- 8 Symbol for tool connection (option)
- 9 Silence kit on/off button
- 10 Tool connection on/off button (option)
- 11 Solution dosage button
- 12 Solution supply on/off button
- 13 Brush ejector

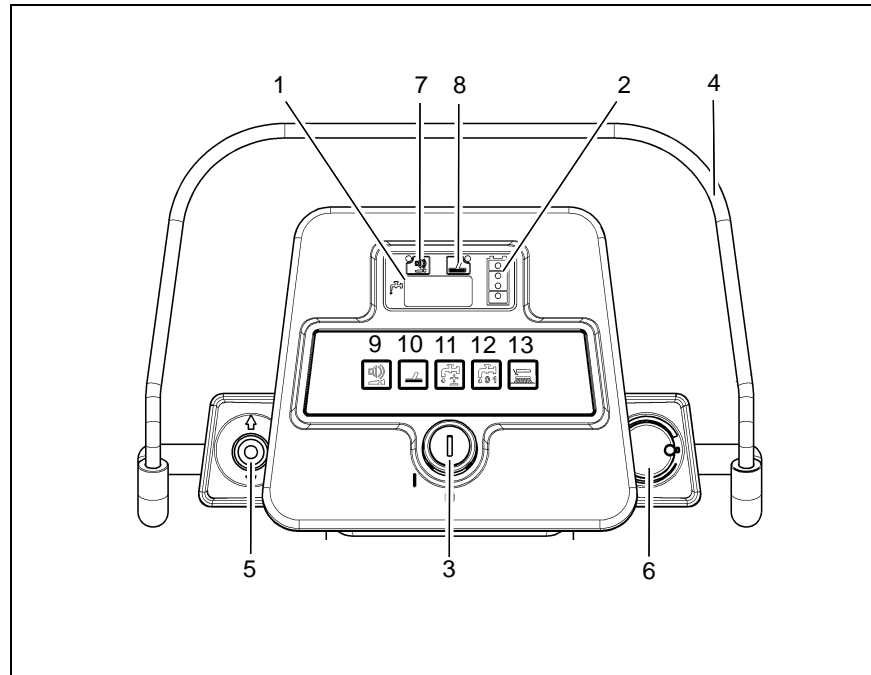
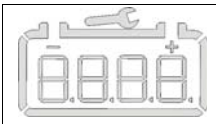

Fig.10 Scrubmaster B30 CL

## Operation



### Indicator field (Fig. 10/1)

The indicator field provides a central function monitoring facility and indicates all operating states.

### Operating hour counter

After switching on, the software version, last service code and current number of operating hours appear briefly in the indicator field. Then the charge status is indicated.

### Service indicator

The service indicator lights up when an error has occurred in the system and the cleaning or driving process is interrupted. In addition to the service indicator (wrench), a four-digit service code appears in the indicator field. The dots of the service code flash and an acoustic beep is issued.

Clear the fault or note down the service code and inform your authorized Hako dealer.

### Charge status indicator

After switching on, the indicator field displays the charge status indicator. The four icons indicate the current battery charge status during operation.

4 icons: charge level 100%-60%

3 icons: charge level 60%-40%

2 icons: charge level 40%-20%

1 icon: charge level less than 20%

Battery icon flashes = three minutes until OFF.

Charge the batteries, refer to section 5.4

## Operation

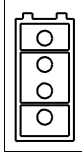

### Charge mode indicator (Fig. 10/2)

Four green LEDs indicate the charge mode with reference to the current charging stage. If the battery is discharged, the two bottom LEDs light up. While charging, the other LEDs light up one by one.

The number of LEDs lit up corresponds to the following charge status:

1 LED:

Soft start, battery pre-charge cycle

2 LEDs:

Main charge - battery is being charged

3 LEDs:

Trickle charge - charge level 80%

4 LEDs:

Charge cycle complete - charge level 100%. Charge retention is enabled.



Flashing of the bottommost LED is indicative of a fault. See charger manual.



Hako chargers are designed to work continuously, i.e., at the end of the charge cycle, the charger automatically enables charge retention to ensure that the battery is always perfectly charged. To get the most from your battery and optimize its service life, it is best to always fully charge the battery (four LEDs on).



### Main switch (Fig. 10/3)

The main switch is used to switch the electrical system on and off. The indicator field displays the software version and last service code briefly after switching on.



Remove the key to prevent unauthorized use of the machine.

### Bail system switch (Fig. 10/4)

Letting go of the bail system switch during operation stops the traction drive, the brush head drive and the solution supply. The suction turbine remains switched on.

## Operation



### **Direction switch (Fig. 10/5)**

The direction switch is used to preselect the driving direction for the machine.  
Switch to front = forward drive  
Switch to rear = reverse drive  
To change the driving direction, bring the machine to a stop, select the new direction and start again.



### **Driving speed control (Fig. 10/6)**

The driving speed control is a continuously adjustable knob to set the machine speed.



### **Symbol for silence kit (Fig. 10/7)**

The LED lights up when the silence kit function is switched on.



### **Symbol for tool connection (option) (Fig. 10/8)**

The LED lights up when the tool connection function is switched on.



### **Silence kit button (Fig. 10/9)**

The silence kit button is used to switch low-noise operation on and off. The silence kit reduces the noise made by the vacuuming equipment.



### **Tool connection button (option) (Fig. 10/10)**

The tool connection button is used to switch operation of the spray and vacuum tool on and off.

## Operation

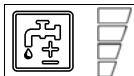

### Solution dosage button (Fig. 10/11)

The solution quantity can be adjusted during operation. The level selected appears as an icon in the indicator field.

To adjust the solution quantity, press the button until the required level is indicated. Conditions to set the solution quantity:

- Main switch is switched on
- Brush head is lowered
- Pull up the bail system switch



### Solution supply on/off button (Fig. 10/12)

The button serves to switch the solution supply on and off. When the brush is switched on, the last solution quantity set is automatically reactivated but this setting can be altered, however, with the solution dosage button.



### Brush ejection button (Fig. 10/13)

The brush can be removed for maintenance purposes by pressing a button.

#### Eject brush:

Raise the brush head. Press the button for approx. 5 seconds when the brush head is raised. Brush ejection is indicated in the indicator field by four icons which light up successively.



After brush ejection, the top and bottom row of symbols flash alternately. The machine is not ready to operate. Switch the machine off using the main switch.



#### Attach brush:

Switch the machine on again using the main switch. Position the brush centered under the raised brush head. Lower the brush head. When the brush head drive is switched on by means of the bail system switch, the brush is automatically attached.

## Operation

### 3.2.2 Operating elements on the machine

- 1 Solution tank filling neck
- 2 Squeegee lift lever
- 3 Solution filter
- 4 Solution draining hose
- 5 Power supply line to charger
- 6 Brush head lift foot pedal
- 7 Waste water draining hose
- 8 Hand valve for water dosage (Scrubmaster B30 only)

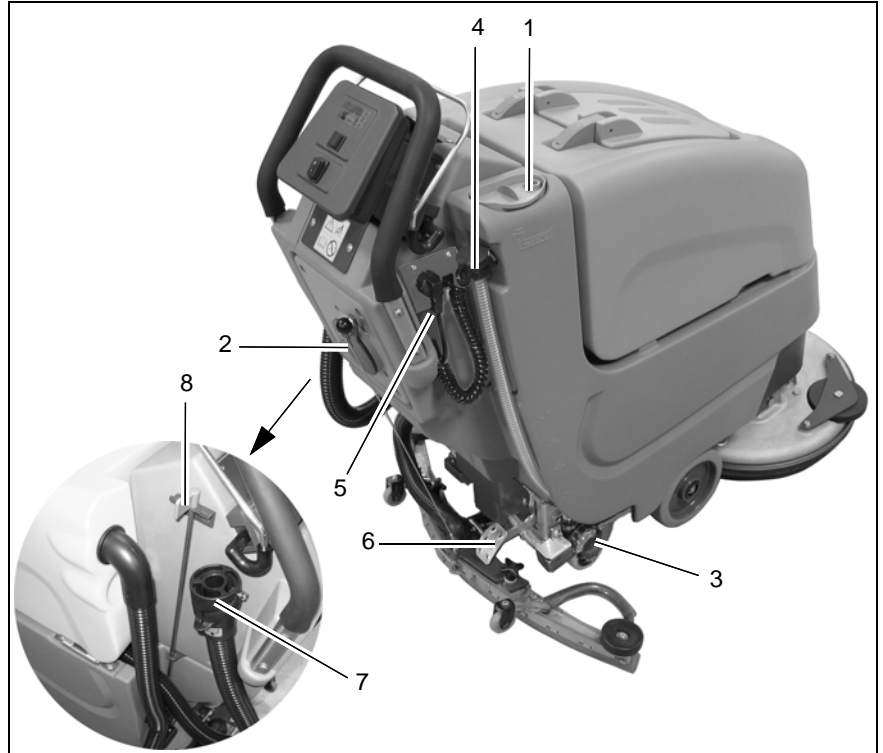

Fig.11 Scrubmaster B30

## Operation

### **Solution tank filling neck (Fig. 11/ 1)**

The solution tank is filled through a detachable filling neck. The fill level can be seen through the draining hose.

### **Squeegee lift hand lever (Fig. 11/2)**

Use the hand lever to lower or lift the squeegee. On Scrubmaster B30 CL machines, this also turns the suction turbine on/off.

### **Solution filter (Fig. 11/3)**

When the solution is fed from the solution tank to the brush head, the solution is cleaned by a filter insert.

### **Solution draining hose (Fig. 11/4)**

The solution tank draining hose is used to drain the solution.

### **Power supply line (Fig. 11/5)**

The power supply line feeds power to the charger. Following completion of the charging process, insert the grounded plug firmly in the holder with the integrated machine immobilizer.

### **Brush head lift foot pedal (Fig. 11/6)**

This pedal raises and lowers the brush head.

### **Waste water draining hose (Fig. 11/ 7)**

Use this hose to drain any waste water previously drawn up into the waste water tank.

### **Solution hand valve (Fig. 11/8)**

Scrubmaster B30 features a hand valve for adjusting the amount of water supplied to the brush head. The solution quantity can be regulated between 0 l/min and 1.85 l/min.



## Technical Data

### 4 Technical Data

Machine length (17"/20")	cm	127
Machine height	cm	109
Machine width without squeegee (17"/20")	cm	50
Machine width with squeegee (17"/20")	cm	78
Working width (17"/20")	cm	43
Squeegee width (17"/20")	cm	76
Area coverage, theoretical (17"/20")	m <sup>2</sup> /h	1720
Nominal voltage	V	24
Power consumption, traction drive (Scrubmaster B30 CL/CLH only)	W	180
Power consumption, aspirating engine	W	410
Power consumption, brush motor	W	720
No. of brushes	Pieces	1
Brush diameter (17"/20")	cm	43
Working speed	kph	4,0
Solution tank	Liter	32
Recovery tank	Liter	34
Weight with batteries (80Ah) (power flow/traction drive)	kg	155/166
Weight with solution and batteries (80Ah) (power flow/traction drive)	kg	189/200

## Technical Data

<b>Noise emission value</b>		Without silence mode	With silence mode
Sound power level ( $L_{wAd}$ ) measured according to DIN EN 60335-2-72 under maximum working conditions:	dB (A)	84	82
The sound pressure level ( $L_{pA}$ ) (at the ear of the operator) measured according to DIN IEC 60335-2-72 under normal working conditions:	dB (A)	64	61
Measurement inaccuracy ( $K_{pA}$ ):	dB (A)	2	2
<b>Vibration</b>			
The weighted effective value of acceleration, measured in accordance with DIN EN ISO 5349-1, to which the upper parts of the body (hand-arm) are exposed under normal working conditions:	$m/s^2$	< 2.5	< 2.5
The weighted effective value of acceleration, measured in accordance with DIN EN ISO 2631-1, to which the body (feet-seat) is exposed under normal working conditions:	$m/s^2$	< 0.5	< 0.5
<b>Battery charger</b>			
Line voltage	V		230
AC mains power	A		1.8
Charging voltage	V		24
Charging rate	A		12.6

### 5 Maintenance and Service

#### General information



It is essential to pay attention to the information in Chapter "Safety Information" before completing any service or maintenance work!

By adhering to the maintenance work recommended by us, you can be sure that the vehicle is always ready to be put into operation.

Maintenance and repair work necessary on a daily and weekly basis can be carried out by a driver trained to complete the work, all other Hako system maintenance may only be completed by personnel who are correspondingly qualified and trained. Please contact your nearest Hako service center or Hako authorized dealer. Failure to observe this annuls any rights to claims under the terms of guarantee in respect of resulting damage or consequential damage.

Always specify the serial number in the case of inquiries and spare parts orders, refer to section 1.7 - Rating plate.

#### 5.1 Hako system maintenance

The Hako system maintenance:

- ensures that the Hako vehicle is always ready for operation (preventive maintenance),
- minimizes operating costs, maintenance and repair costs,
- ensures the vehicle has a long service life.

Hako system maintenance provides individual modules explaining the special technical work to be carried out and prescribes the intervals at which the work should be performed. Parts to be replaced for the individual maintenance tasks are defined and provided in spare parts kits.

#### Hako system maintenance, customer:

Work to be carried out by the customer according to the service and maintenance instructions in the operating manual (daily and weekly).



The machine's parts to be serviced are marked with a yellow dot and yellow areas

The operator is duly instructed when the vehicle is delivered.

#### Hako system maintenance I:

(every 125 operating hours)

Completed by technical experts from an authorized Hako service center in accordance with the specific vehicle system maintenance using spare parts kits.

#### Hako system maintenance II:

(every 250 operating hours)

Completed by technical experts from an authorized Hako service center in accordance with the specific vehicle system maintenance using spare parts kits.

#### Hako system maintenance III S:

(every 500 operating hours, safety check)

Completed by technical experts from an authorized Hako service center in accordance with the specific vehicle system maintenance using spare parts kits. Completion of all legally prescribed, safety-related tests in accordance with UVV-BGV-TÜV-VDE.

# Maintenance and Service

## 5.2 Maintenance Document

<p>Handing over</p> <p>Upgrade Test drive Handing over to the customer Instruction carried out on: at _____ operating hours</p>	<p>Hako-System-Maintenance I 125 operating hours Workshop stamp</p> <p>carried out on: at _____ operating hours</p>	<p>Hako-System-Maintenance II 250 operating hours Workshop stamp</p> <p>carried out on: at _____ operating hours</p>	<p>Hako-System-Maintenance I 375 operating hours Workshop stamp</p> <p>carried out on: at _____ operatin hours</p>
<p>Hako-System-Maintenance III/S 500 operating hours Workshop stamp</p> <p>carried out on: at _____ operating hours</p>	<p>Hako-System-Maintenance I 625 operating hours Workshop stamp</p> <p>carried out on: at _____ operating hours</p>	<p>Hako-System-Maintenance II 750 operating hours Workshop stamp</p> <p>carried out on: at _____ operating hours</p>	<p>Hako-System-Maintenance I 875 operating hours Workshop stamp</p> <p>carried out on: at _____ operatin hours</p>
<p>Hako-System-Maintenance III/S 1000 operating hours Workshop stamp</p> <p>carried out on: at _____ operating hours</p>	<p>Hako-System-Maintenance I 1125 operating hours Workshop stamp</p> <p>carried out on: at _____ operating hours</p>	<p>Hako-System-Maintenance II 1250 operating hours Workshop stamp</p> <p>carried out on: at _____ operating hours</p>	<p>Hako-System-Maintenance I 1375 operating hours Workshop stamp</p> <p>carried out on: at _____ operating hours</p>

## Maintenance and Service

### 5.3 Maintenance Schedule Hako-System Maintenance Customer

The daily and weekly maintenance intervals are to be performed by the customer/operator.

To be performed	Interval	
	daily	weekly
Fill clear water tank and proceed to chemical agent dosage	o	
Charge batteries	o	
Check brush head and clean if required	o	
Check squeegee and clean if required	o	
Empty soiled water tank, clean soiled water tank and suction filter	o	
Clean tank lid sealing of the soiled water tank	o	
Check brush head sealing strips and replace if required		o
Check brushes/pads and replace if required		o
Clean suction hose of soiled water tank		o
Check water filter and clean if required		o
Check squeegee sealing strips and eventually turn round or replace		o
Check clear water supply to brushes and clean if required		o
Check deflector roller of brush head and replace if required		o
Test drive and function test		o

## Maintenance and Service

### Hako-System Maintenance I

The following maintenance works are to be performed by an authorised Hako Service workshop.

To be performed	Interval
	every 125 hours of operation
Check battery charger	o
Check tank lid sealing of the soiled water tank and replace if required	o
Check function of bailsystem and operating panel	o
Check drain hose of the soiled water tank and replace if required	o
Grease joints at the brush lift-out	o
Check wheel fixing screws and tighten (10 Nm) if required	o
Check condition of tyres	o
Grease joints at the squeegee holder	o
Test drive and function test	o

## Maintenance and Service

### Hako-System Maintenance II

The following maintenance works are to be performed by an authorised Hako Service workshop.

To be performed	Interval
	every 250 hours of operation
Perform maintenance works according to Hako-System Maintenance I	o
Inspect steering rollers for tread damages and bearing slackness and replace if required	o
Check function of water pump and replace if required	o
Check drain hose of the soiled water tank and replace if required	o
Check deflector roller of the brush head and replace if required	o
Check suction hose for tight fitting and damages and replace if required	o
Check supporting wheel of the squeegee and replace if required	o
Test drive and function test	o

## Maintenance and Service

### Hako-System Maintenance III/S (Safety check)

The following maintenance works are to be performed by an authorised Hako Service workshop at least once yearly.

To be performed	Interval
	every 500 hours of operation
Perform maintenance works according to Hako-System Maintenance II	o
Check drive protection of the charger	o
Check function of suction turbine and replace if required (replace at the latest after 1000 operating hours)	o
Check brake of the travel drive motor (Scrubmaster B30 CL only)	o
Clean travel drive motor (Scrubmaster B30 CL only) from carbon dust and check carbon brushes for smooth operation and wearing and replace carbon brushes if required	o
Clean brush motors from carbon dust and check carbon brushes for smooth operation and wearing and replace carbon brushes if required (replace at the latest after 1000 operating hours)	o
Test drive and function test	o



## Maintenance and Service

### 5.4 Battery system

- 1 Indicator field w/ charge status indicator
- 2 Charge mode indicator
- 3 On-board charger
- 4 Charger power plug
- 5 Power plug receptacle and vehicle immobilizer
- 6 Battery terminals
- 7 Batteries
- 8 Waste water tank
- 9 Circuit diagram
- 10 Connecting line

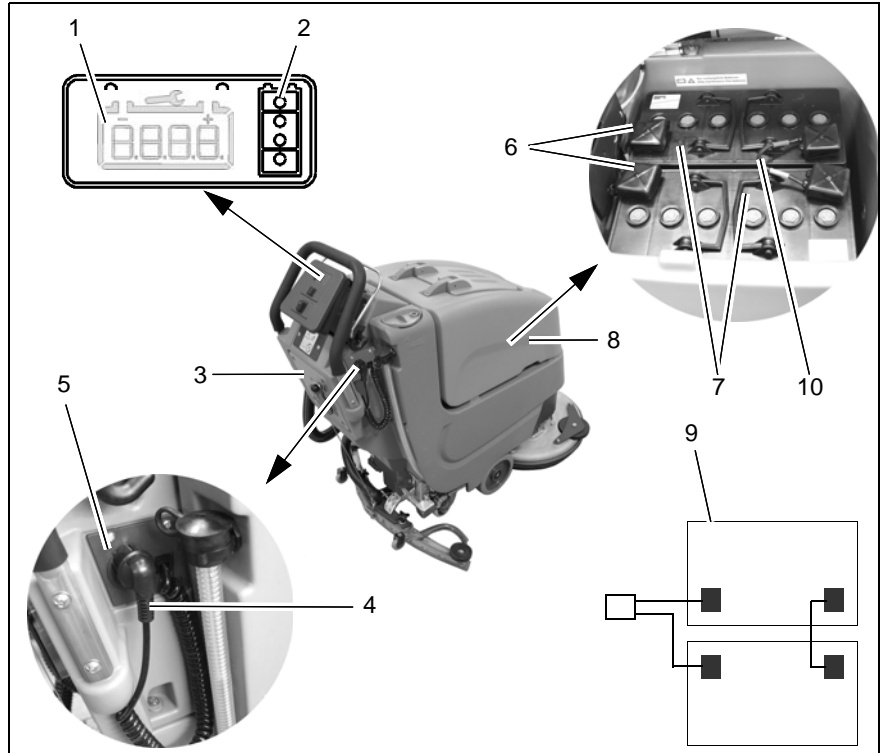

Fig.12

### 5.4.1 Charging batteries



Complete an initial battery charge cycle to properly charge the batteries prior to running the machine for the first time. Hako assumes no liability for damage to the battery caused by a fault when the battery is charged for the first time.

Ensure sufficient ventilation in the charging area when charging the batteries – risk of explosion.

Before charging the battery, wait until at least one charge status indicator bar has extinguished after operating the machine. The battery is charged by the integrated on-board charger (Fig. 12/3):

1. Turn the machine off.
2. Remove the power plug (Fig. 12/4) from its receptacle on the right-hand side.
3. Plug the connector into a 230V mains outlet.

Charging will start automatically. The charge mode indicator (Fig. 12/2) shows the progress. Pay attention to

the information in the operating manuals supplied with the charger and the battery.



You cannot turn on the machine while charging. The machine will not be ready to operate until the power plug has been returned to its receptacle (Fig. 12/5)

### 5.4.2 Charge status indicator

Check the indicator field (Fig. 12/1) for the current charge status of the batteries during operation. The charge status indicator is connected to a total discharge signal transducer (TSG) in the machine control unit. Four segments on the display are indicative of the batteries being fully charged. The segments extinguish one by one as more power is drawn from the batteries. At the discharge limit, the battery icon starts to flash and the TSG turns off the cleaning functions to prevent total battery discharge (machines with a traction drive can still be moved at reduced speed). Charge the batteries immediately!

## Maintenance and Service

### 5.4.3 Total discharge signal transducer (TSG)

The machine features a total discharge signal transducer to prevent total battery discharge.

The TSG is set to the built-in batteries at the factory. The TSG needs to be adapted to other batteries approved by Hako.



The total discharge signal transducer may only be adjusted by a licensed Hako workshop!

### 5.4.4 Servicing the driving batteries

Never keep discharged batteries but recharge them immediately!

For information on servicing driving batteries, refer to operating manual 88-60-2556.

### 5.4.5 Replacing the batteries



Use batteries approved by Hako only!



Use maintenance-free and sealed batteries only!



Batteries to be replaced by qualified service technicians only!



We recommend our licensed Hako Customer Service.

### 5.4.6 Disposing of batteries

Used batteries with the recycling symbol contain reusable commodities. Do not throw into the household waste. See section 1.6 Ecological Information.

## 5.5 Solution tank

- 1 Solution tank
- 2 Marking
- 3 Fill level hose
- 4 Solution filter
- 5 Tank cap

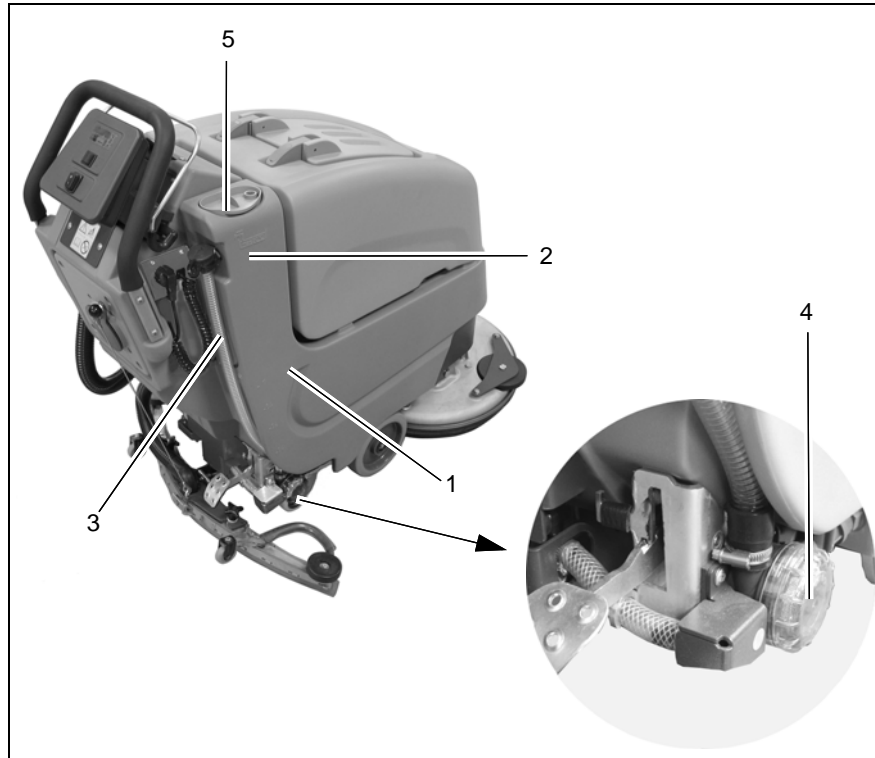

Fig.13 Scrubmaster B30

## Maintenance and Service

### 5.5.1 Filling the solution tank

Fill the solution tank (Fig. 13/1) before starting work or as necessary. Park the vehicle on a level floor area.

Open the tank cap (Fig. 13/5) and fill the solution tank up to the maximum marking (1/1)(Fig. 13/2).

### 5.5.2 Emptying the solution tank

Park the machine so that the fill level hose (Fig. 13/3) is above a drain in the floor. Remove the fill level hose from the holder and remove the cover.

### 5.5.3 Cleaning the fresh water filter

Check the solution filter (Fig. 13/4) weekly and clean or replace it as necessary.



Only clean the solution filter when the tank is empty.

1. Empty the solution tank (Fig. 13/1), see paragraph 5.5.2.
2. Screw the filter cap off.
3. Remove the filter element in the filter housing to clean it. Replace it with a new one, if necessary.
4. Replace the filter element and filter cap.

### 5.6 Soiled Water tank

- 1 Soiled Water Tank
- 2 Drain hose
- 3 Suction filter
- 4 Tank lid
- 5 Drain valve sealing
- 6 Tank lid sealing

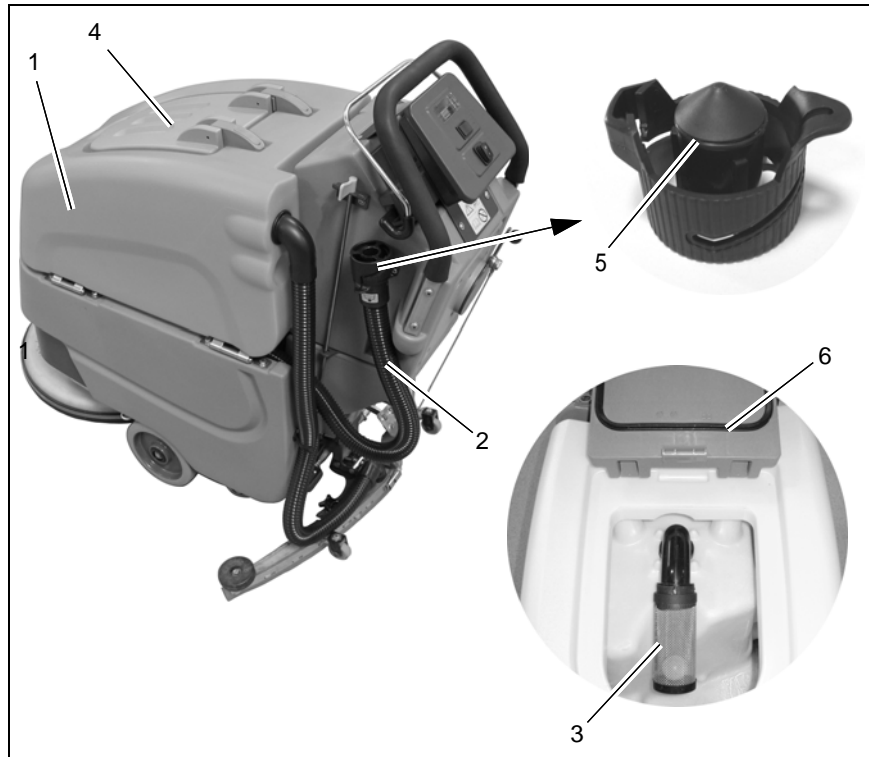

Fig.14

Scrubmaster B30

## Maintenance and Service

### 5.6.1 Empty Soiled Water Tank

Clean soiled water tank (Fig. 14/1) at daily intervals, as required or upon acoustic signal (increased suction turbine speed).

1. Take machine to appropriate place for discharge.
2. Park machine such that drain hose attains drain aperture in the floor.
3. Switch off machine.



Observe the legal provisions and the local regulations for disposal of detergents!

4. Take drain hose (Fig. 14/2) from holder and empty soiled water tank completely.

### 5.6.2 Clean Soiled Water Tank

Clean soiled water tank (Fig. 14/1) at daily intervals or as required.

1. Empty soiled water tank, see paragraph 5.6.1.
2. Open tank lid (Fig. 14/4) of the soiled water tank.
3. Take drain hose (Fig. 14/2) from holder and empty soiled water tank completely.
4. Remove remaining dirt by rinsing with clear water.
5. Rinse drain hose as well.

### 5.6.3 Clean Suction Filter

Check suction filter (Fig. 14/3) for function at daily intervals and clean if required. The suction filter is clipped and can be easily removed.

### 5.6.4 Checking the Draining valve seal

Check the functionality of the draining valve (Fig. 14/5) daily and change it after 125 operating hours at the latest. Remove the draining hose from the holder. Turn the draining valve 90° and pivot away from the draining hose. Grease the new seal and pin with Molykote.

### 5.6.5 Checking the Tank lid seal

Check the functionality of the seal in the tank cap (Fig. 14/6) daily and change it after 125 operating hours at the latest.

## 5.7 Brush head

- 1 Brush
- 2 Brush head
- 3 Brush head lift lever
- 4 Brush ejection button
- 5 Deflector roller
- 6 Sealing strip

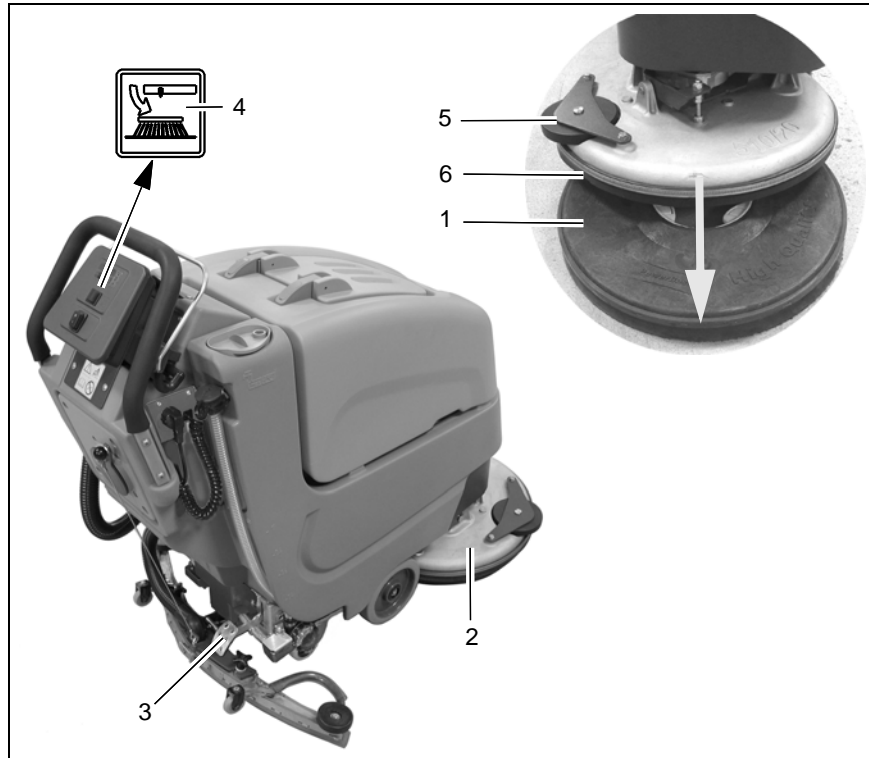

**Fig.15 Scrubmaster B30**



## Maintenance and Service

### 5.7.1 Changing the brushes

Check the brushes (Fig. 15/1) in the brush head (Fig. 15/2) weekly for signs of wear. In the case of wear to a brush length of 1.5 cm, the brushes must be changed.

#### Eject brush:

Raise the brush head using the lever (Fig. 15/3). Press the button (Fig. 15/4) for approx. 5 seconds when the brush head is raised. Brush ejection is indicated in the indicator field by four icons which light up successively.



After brush ejection, the top and bottom row of symbols flash alternately. The machine is not ready to operate. Switch the machine off using the main switch.

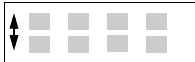

#### Attach brush:

Switch the machine on again using the main switch. Position the brush centered under the raised brush head. Lower the brush head. When the brush head drive is switched on by means of the dead-man's switch of the bail system, the brush is automatically attached.

### 5.7.2 Changing the deflector roller

Check the deflector roller (Fig. 15/5) weekly and change it as necessary.

### 5.7.3 Changing the sealing strip

Check the sealing strip (Fig. 15/6) weekly and change it as necessary. To do this, loosen the fastening device and remove the sealing strip. Installation is carried out in the reverse sequence.

## Maintenance and Service

### 5.8 Squeegee

- 1 Squeegee
- 2 Star-shaped knob
- 3 Adjusting bolt for angle adjustment
- 4 Suction hose
- 5 Fastening device
- 6 Washers for height adjustment

#### 5.8.1 Cleaning the squeegee

Check the squeegee (Fig. 16/1) daily and clean it as necessary.

To clean the squeegee raise it, disconnect the suction hose (Fig. 16/4), loosen the two star-shaped knobs (Fig. 16/2) and remove the squeegee.

#### 5.8.2 Changing the sealing strips

Check the inner and outer sealing strips on the squeegee (Fig. 16/1) weekly for signs of wear. The sealing strips can be turned four times (90°) and reused.

1. Raise the squeegee.
2. Disconnect the suction hose, loosen the two star-shaped knobs and remove the squeegee.
3. Loosen the fastening device (Fig. 16/5) and remove the outer sealing strip. Turn the sealing strip or replace it, as necessary. Change the inner sealing strip in the same way.

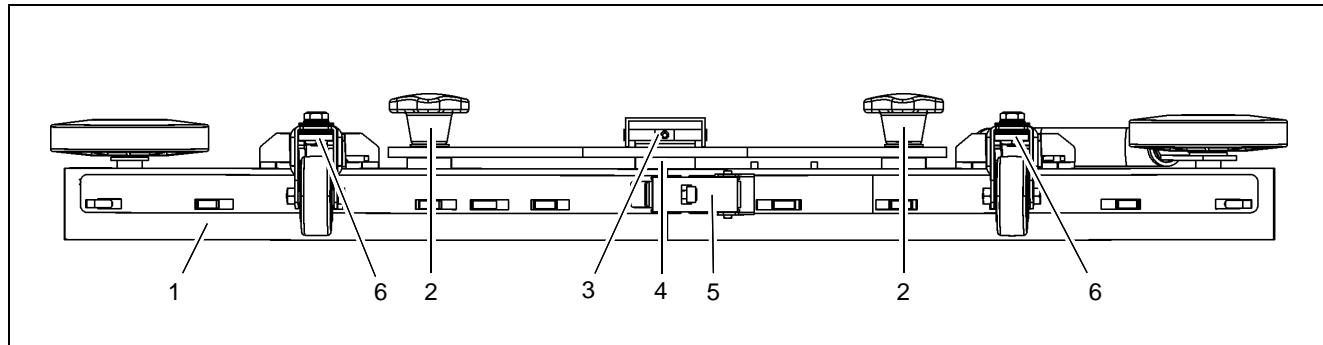

Fig.16

### 5.8.3 Adjusting the sealing strips Angle adjustment

The angle adjustment is decisive in controlling whether the squeegee's sealing strips lie evenly on the floor.

1. Park the machine on a level surface and lower the squeegee.
2. Loosen the counter nut on the adjusting bolt (Fig. 16/3) and adjust the squeegee with the adjusting bolt until the ends of the sealing strips just make contact with the floor.

Fig. A

Turn the adjusting bolt clockwise: Distance between sealing strip and floor is decreased in the middle.

Fig. B

Turn the adjusting bolt counterclockwise: Distance between sealing strip and floor is increased in the middle.

3. Switch the machine on and check the suction pattern. When driving, the sealing strips must make as even a contact as possible all around (center and outer sides).
4. Tighten the counter nut on the adjusting bolt at 7 Nm.

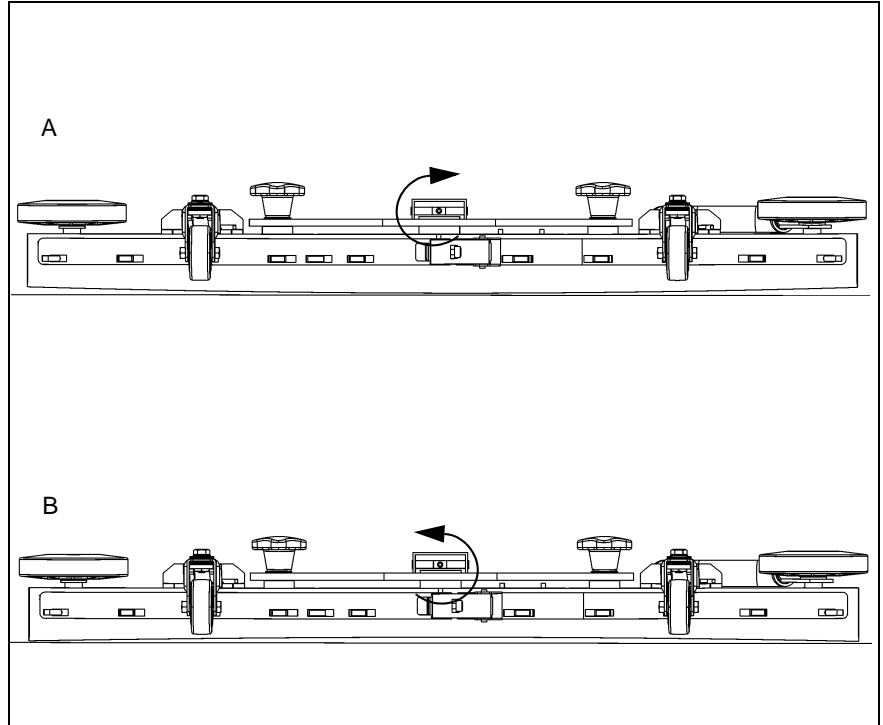

Fig.17

### Height adjustment

The height adjustment is set to 3 mm at the factory. If streaks appear despite an optimum angle adjustment, the distance of the rollers to the floor must be adjusted by changing the number of washers on the holder.

In the case of very smooth floors, e.g. varnished floors, linoleum etc.:

Number of washers = 2. This corresponds to a distance of approx. 2 mm to the floor.

In the case of very uneven floors, e.g. badly laid tiles (water does not run off):

Number of washers = 4. This corresponds to a distance of approx. 4 mm to the floor.

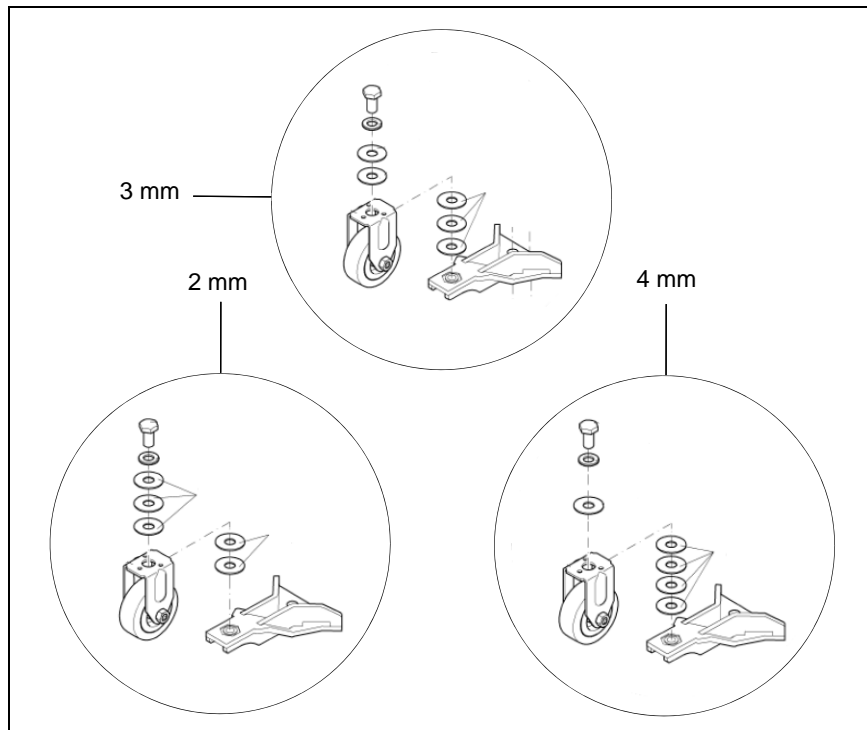

Fig.18

## EC-Declaration of Conformity (according to Directive 2006/42/EC)

**Hako GmbH**  
**Hamburger Straße 209-239**  
**D-23843 Bad Oldesloe**

declare under our sole responsibility,  
that the product

**Scrubmaster B30 / B30 CL**  
**Type: 7715**

to which this declaration relates, corresponds to the relevant basic safety and health requirement of the Directive 2006/42/EC, and to the requirements of the other relevant Directives: 2004/108/EC.

For the relevant implementation of the safety and health requirements mentioned in the Directives, the following standard (s) and / or technical specification (s) has (have) been respected:

**DIN EN 60335-2-72**  
**DIN EN 55012**  
**DIN EN 61000-6-2**

Name of the person authorised for Hako to compile the technical file:

Ludger Lüttel

Bad Oldesloe, 22.04.2014



Dr. Rainer Bavendiek  
Director R&D

**Hako**

*Clean ahead*

# Advanced Technology for a Cleaner, Better Environment



Hako GmbH • Hamburger Str. 209-239 • D-23843 Bad Oldesloe  
☎+49 4531 806-0 • Fax+49 4531 806-338

88-10-2996 - 3100-05