 <p>Communication Systems, Inc. A Leader in Patient Communication Solutions™</p>	MODEL NUMBER: <h2 style="text-align: center;">PD168-242</h2>	Document Number: PD196-402R1
	<h3 style="text-align: center;">50" and 55" TV Wall Mount Kit Installation Instructions</h3>	<h3 style="text-align: center;">Page 1 of 2</h3>

SCOPE:

TO MOUNT A TV USING A PDI PD168-242 WALL MOUNT KIT, TO EXISTING WALL MOUNTS.

TOOL LIST

1. P1 OR P2, PHILLIPS SCREW DRIVER
2. SAFETY GLASSES/GOGGLES
3. LEVEL

SAFETY STEPS:

1. ALWAYS WEAR SAFETY GLASSES/GOGGLES TO PREVENT INJURY FROM DEBRIS.
2. FOLLOW THE INSTALLATION/REMOVAL INSTRUCTIONS FOR YOUR EXISTING PRODUCTS.

NOTE:

ASSEMBLY STEP ORDER CAN BE MODIFIED FOR SPECIFIC INSTALLATION NEEDS.

STEP 1:

ATTACH THE (4) PD181-825 MOUNTING BRACKETS (#2) TO THE BACK OF THE E50/A55 LED TV USING FOUR PDIPPHMSM6X110 SCREWS (#6).

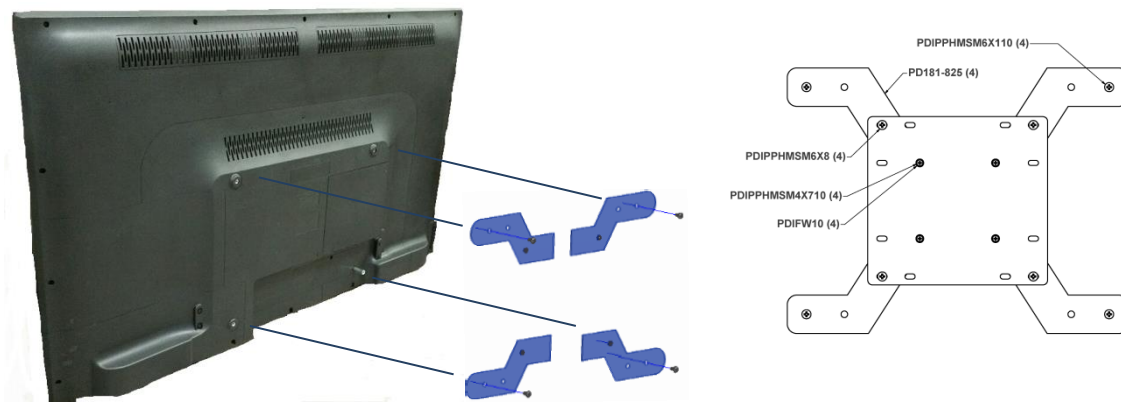

STEP 2:

ATTACH THE PD181-672 PLATE (#1) TO THE EXISTING 100mm VESA MOUNT USING FOUR PDIPPHMSM4X76 SCREWS (#4) AND FOUR PDIITLW10 WASHERS (#3). MAKE SURE THE EXISTING MOUNTING BRACKET IS ATTACHED TO THE SIDE OF THE CHOSEN PLATE WITH THE FOUR ROUND ENDS OF THE M4 INSETS. THE SIDE WITH THE FOUR HEX ENDS WILL GO TOWARDS THE BACK OF THE SET.

STEP 3:

ATTACH PARTS PREVIOUSLY ASSEMBLED ON STEP #2 TO TV USING FOUR PDIPPHMSM6X18 SCREWS (#7).

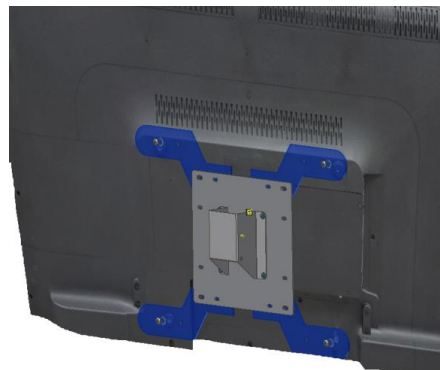

ITEM	PART NUMBER	DESCRIPTION	QTY
1	PD181-672	200mm TO 100mm ADAPTER PLATE	1
2	PD181-825	50" TV MOUNTING BRACKET	4
3	PDIFW10	#10 FLAT WASHER	4
4	PDIPPHMSM4X76	M4-.7 X 6mm PPHMS	4
5	PDIPPHMSM4X710	M4-.7 X 10mm PPHMS	1
6	PDIPPHMSM6X110	M6 X 1 10mm PHILLIPS SCREW	4
7	PDIPPHMSM6X18	M6 x 1 8mm PHILLIPS SCREW	4

VESA PATTERNS:

100MM X 100MM WITH M4 THREADS

100MM X 200MM FOR M5 FASTENERS

200MM X 200MM FOR M6 FASTENERS

PD181-672

