

APPLICATION FOR OSHPD PREAPPROVAL OF MANUFACTURER'S CERTIFICATION (OPM)

OFFICE USE ONLY

APPLICATION #: OPM-0516-13

OSHPD Preapproval of Manufacturer's Certification (OPM)

Type: New Renewal Update to Pre-CBC 2013 OPA Number: _____

Manufacturer Information

Manufacturer: PDi Communication Systems, Inc.

Manufacturer's Technical Representative: Michael Maraan

Mailing Address: 40 Greenwood Lane, Springboro, OH 45066

Telephone: 937-550-2845

Email: mmaraan@pdiam.com

Product Information

Product Name: 500, 1000 and 1400 Series Articulating Swing Arm

Product Type: TV/Monitor swing arm wall and floor mount

Product Model Number: PDI-AA-500, PDI-AA-1000, PDI-AA-1400, P14W, P14T2, P19A/T/S/C, MEDTV16, MEDTAB16, PDI-886BASE, PDI-886BASE-W

General Description: Wall mounted and floor mounted TV/monitor articulating swing arm.

Applicant Information

Applicant Company Name: PDi Communication Systems, Inc.

Contact Person: Dean Heyl

Mailing Address: 40 Greenwood Lane, Springboro, OH 45066

Telephone: 937-550-2840

Email: dhey@pdiam.com

I hereby agree to reimburse the Office of Statewide Health Planning and Development review fees in accordance with the California Administrative Code, 2016.

Signature of Applicant: 

Date: 30 November 2018

Title: Director of Engineering

Company Name: PDi Communication Systems, Inc.

Registered Design Professional Preparing Engineering Recommendations

Company Name: Degenkolb Engineers

Name: Adrian M. Nacamuli California License Number: SE 4857

Mailing Address: 1300 Clay Street, Suite 900, Oakland CA 94612

Telephone: 510-250-1216 Email: nacamuli@degenkolb.com

OSHPD Special Seismic Certification Preapproval (OSP)

- Special Seismic Certification is preapproved under OSP-
(Separate application for OSP is required)
- Special Seismic Certification is not preapproved

Certification Method(s)

- Testing in accordance with: ICC-ES AC156 FM 1950-16
- Other* (Please Specify): _____

*Use of criteria other than those adopted by the California Building Standards Code, 2016 (CBSC 2016) for component supports and attachments are not permitted. For distribution system, interior partition wall, and suspended ceiling seismic bracings, test criteria other than those adopted in the CBSC 2016 may be used when approved by OSHPD prior to testing.

- Analysis
- Experience Data
- Combination of Testing, Analysis, and/or Experience Data (Please Specify): _____

List of Attachments Supporting the Manufacturer's Certification

- Test Report Drawings Calculations Manufacturer's Catalog
- Other(s) (Please Specify): _____

OFFICE USE ONLY – OSHPD APPROVAL VALID FOR CBC 2016 & ALL PRE-2016 CODE BASED PROJECTS

Signature: Sonia Eliseo Date: 8/15/2019

Print Name: Sonia Eliseo

Title: Senior Structural Engineer

Condition of Approval (if applicable): _____



OSHPD PRE-APPROVAL OF MANUFACTURER'S CERTIFICATION

OPM-0516-13

PDI COMMUNICATION SYSTEMS INC.

DEGENKOLB ENGINEERS
1300 Clay Street, Suite 900
Oakland, CA 94612
510.272.9040 PHONE
510.272.5926 FAX

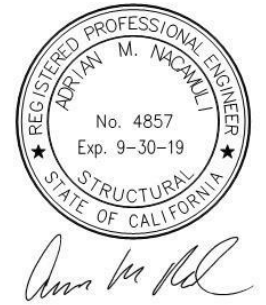

ARTICULATING SWING ARM MODELS

PDI-AA-500
PDI-AA-1000
PDI-AA-1400

PDI MONITOR MODELS

P14W MEDTV16
P14T2 MEDTAB16
P19A/T/S/C

WALL MOUNT BRACKET MODELS

PDI-179AV
PDI-871

FLOOR MOUNT BASE PLATE MODELS

PDI-886BASE
PDI-886BASE-W

GENERAL NOTES:

1. THIS OSHPD PREAPPROVAL OF MANUFACTURER'S CERTIFICATION (OPM) IS BASED ON THE CBC 2016. THE DEMAND (DESIGN FORCES) FOR USE WITH THIS OPM SHALL BE BASED ON THE CBC 2016.

2. PRE-APPROVED DESIGN AND MATERIALS CONFORM WITH THE 2016 EDITION OF THE CALIFORNIA BUILDING CODE AND ITS REFERENCED STANDARDS. DETAILS WITHIN THIS APPROVAL MAY BE USED ANYWHERE IN THE STATE OF CALIFORNIA WHERE S_{DS} VALUE IS EQUAL OR SMALLER THAN THE S_{DS} VALUES LISTED FOR EACH CASE.

3. SEISMIC FORCES ON EQUIPMENT DETERMINED PER THE 2016 CBC & ASCE 7-10 SECTION 13.3. ALL LOADS IN THIS PRE-APPROVAL ARE AT STRENGTH LEVEL AND SHALL BE USED FOR STRENGTH DESIGN.

WALL MOUNTED	FLOOR MOUNTED			
CASE 1 & 2 (PG. 2 & 3)	CASE 3 (PG. 11)	CASE 4 (PG. 11)	CASE 5 (PG. 12)	CASE 6 (PG. 12)
$S_{DS} = 2.5$ $a_p = 2.5$ $I_p = 1.5$ $R_p = 2.5$ $z/h \leq 1.0$ $F_{p,h} = 4.50 W_p$ $F_{p,v} = 0.50 W_p$	$S_{DS} = 1.8$ $a_p = 2.5$ $I_p = 1.5$ $R_p = 2.5$ $z/h = 0.0$ $\Omega_o = 2.5$ $F_{p,h} = 1.08 W_p$ $F_{p,v} = 0.36 W_p$	$S_{DS} = 2.5$ $a_p = 2.5$ $I_p = 1.5$ $R_p = 2.5$ $z/h \leq 1.0$ $\Omega_o = 2.5$ $F_{p,h} = 4.50 W_p$ $F_{p,v} = 0.50 W_p$	$S_{DS} = 2.5$ $a_p = 2.5$ $I_p = 1.5$ $R_p = 2.5$ $z/h = 0$ $\Omega_o = 2.5$ $F_{p,h} = 1.50 W_p$ $F_{p,v} = 0.50 W_p$	$S_{DS} = 2.0$ $a_p = 2.5$ $I_p = 1.5$ $R_p = 2.5$ $z/h \leq 0.9$ $\Omega_o = 2.5$ $F_{p,h} = 3.36 W_p$ $F_{p,v} = 0.40 W_p$

4. THE STRUCTURAL ENGINEER-OF-RECORD (S.E.O.R.) IS RESPONSIBLE FOR THE FOLLOWING:

- VERIFY THAT THE ANCHORS ARE AN ADEQUATE DISTANCE FROM ANY SLAB OPENINGS OR EDGES.
- VERIFY THAT THE ANCHORS ARE AN ADEQUATE DISTANCE FROM ANY NEW OR EXISTING ANCHORS.
- VERIFY THE ADEQUACY OF ANY NEW OR EXISTING MEMBERS THE SWING ARM IS ANCHORED TO THAT ARE NOT WITHIN THE SCOPE OF THIS OPM. INCLUDE THE FORCES EXERTED ON THESE ELEMENTS BY THE SWING ARM IN ADDITION TO ALL OTHER LOADS AND FORCES PRESENT IN THE STRUCTURE.
- VERIFY THAT THE INSTALLATION IS IN CONFORMANCE WITH THE 2016 CBC AND WITH THE DETAILS SHOWN IN THIS PRE-APPROVAL. VERIFY THAT THE EQUIPMENT'S ACTUAL WEIGHT, CG LOCATION, ANCHOR LOCATIONS, ANCHOR DETAILS AND THE MATERIAL AND GAGE OF THE UNIT WHERE ATTACHMENTS ARE MADE AGREE WITH THE FORMATION SHOWN IN THIS PRE-APPROVAL.

5. THE MANUFACTURER SUPPLIED BASE BRACKETS HAVE BEEN EVALUATED FOR THE WORST CASE LOADING PER THE 2016 CBC. STRUCTURAL ENGINEER-OF-RECORD (S.E.O.R.) SHALL EVALUATE BRACKET ANCHORAGE FOR CONDITIONS THAT VARY FROM THIS PRE-APPROVAL.

6. CONTRACTOR/INSPECTOR OF RECORD MUST VERIFY ANCHOR SPACING TO ADJACENT EQUIPMENT IS TO BE GREATER THAN 12".

7. THIS OPM COVERS ONLY THE SUPPORTS AND ATTACHMENTS OF THE UNIT TO THE STRUCTURE.

8. EXPANSION OR WEDGE ANCHORS INTO CONCRETE: HILTI KB-TZ (ICC ESR-1917). INSTALL ANCHORS IN ACCORDANCE WITH THE ICC REPORT AND MANUFACTURER'S RECOMMENDATIONS. TEST AT LEAST 50% OF ANCHORS NO SOONER THAN 24 HOURS AFTER INSTALLATIONS. TESTS SHALL BE CONDUCTED IN THE PRESENCE OF THE INSPECTOR OF RECORD (IOR) AND A REPORT OF THE TEST RESULTS SHALL BE SUBMITTED TO OSHPD.

TEST PER ONE OF THE FOLLOWING METHODS:

a. DIRECT PULL TENSION TEST: ANCHOR IS ACCEPTABLE IF NO MOVEMENT IS OBSERVED AT THE TEST LOAD GIVEN IN TABLE BELOW. MOVEMENT MAY BE DETERMINED WHEN THE WASHER UNDER THE NUT BECOMES LOOSE.

b. TORQUE WRENCH TEST: TEST ANCHORS TO THE REQUIRED TORQUE LOAD GIVEN IN TABLE BELOW WITHIN THE LIMIT OF ONE-HALF TURN OF THE NUT.

9. IF ANY ANCHOR FAILS DURING TESTING, UNIT MUST BE MOVED SO THAT NO ANCHOR IS WITHIN 12" OF AN ABANDONED ANCHOR.

a. AVOID DAMAGING EXISTING STEEL REINFORCING IN CONCRETE SLAB WHEN INSTALLING EXPANSION ANCHORS.

b. PROVIDE FOR FULL THREAD ENGAGEMENT OF NUT AND WASHER.

ANCHOR TEST LOAD VALUES									
ANCHOR TYPE	ANCHOR DIAMETER	EMBED hef	TENSION LOAD (LBS)	TORQUE LOAD (FT-LBS)	f'_c MIN (PSI)	MINIMUM EDGE DIST REQ.	MINIMUM SPACING REQ.	CONCRETE TYPE	MINIMUM THICKNESS
HILTI KB-TZ	3/8"	2"	1,250	25	3,000	36"	4.75"	NORMAL WEIGHT	4" AT SOLID SLAB SECTION 3-1/4" AT CONC. OVER METAL DECK
HILTI KB-TZ	3/8"	2"	650	25	3,000	36"	4.75"	SAND LIGHT WEIGHT	4" AT SOLID SLAB SECTION 3-1/4" AT CONC. OVER METAL DECK

EQUIPMENT PROPERTIES

MONITOR ARMS		
MODEL #	LENGTH	WEIGHT
PDI-AA-500	56.0"	14 LBS
PDI-AA-1400	68.0"	17 LBS
PDI-AA-1000	71.5"	17 LBS

WALL BRACKET - ADC12 ALUMINUM		
Fy = 24 KSI MIN.		
MODEL #	DIMENSIONS (IN)	WEIGHT
PDI-179AV	SEE PG. 4	6 LBS
PDI-871	SEE PG. 4	6 LBS

MONITOR PROPERTIES		
MODEL #	DIMENSIONS (IN)	WEIGHT (LBS)
P14W	14.5 x 11 x 1.9	7
P14T2	14.5 x 11 x 1.9	7
MEDTV16	18 x 13 x 3	10
MEDTAB16	18 x 13 x 3	10
P19A/T/S/C	20 x 13.75 x 2.5	13

BACKER PLATES			
MODEL #	L x W	THICKNESS	MATERIAL
PDI-254I	18" x 10"	0.1196"	A-653
PDI-254I-24	26" x 10"	0.1196"	A-653
PDI-255E	18" x 10.35"	0.1196"	A-1008 CS GRADE B
PDI-255E-24-B-C-G	15" x 10.35"	0.1196"	A-1008 CS GRADE B
PDI-218	10" x 6.50"	0.1196"	A-1008 CS GRADE B
PDI-219C	10" x 7.12"	0.1196"	A-1008 CS GRADE B
PD-133-960	10" x 7.12"	0.049"	A-1008 CS GRADE B



OSHPD PRE-APPROVAL OF MANUFACTURER'S CERTIFICATION

OPM-0516-13

PDi COMMUNICATION SYSTEMS INC.

DEGENKOLB ENGINEERS
1300 Clay Street, Suite 900
Oakland, CA 94612
510.272.9040 PHONE
510.272.5926 FAX



Adrian M. Nacmille

ARTICULATING SWING ARM MODELS

PDI-AA-500
PDI-AA-1000
PDI-AA-1400

PDI MONITOR MODELS

P14W MEDTV16
P14T2 MEDTAB16
P19A/T/S/C

WALL MOUNT BRACKET MODELS

PDI-179AV
PDI-871

FLOOR MOUNT BASE PLATE MODELS

PDI-886BASE
PDI-886BASE-W

CASE 1 ($z/h \leq 1.0$)
 $S_{ds} \leq 2.5$

SEISMIC SUPPORTS & ATTACHMENTS

SINGLE ARM, WALL-MOUNTED

SHEET NOTES:

1. FOR DESIGN FORCES AND FACTORS SEE GENERAL NOTES ON PAGE 1.
2. THIS PREAPPROVAL ENCOMPASSES ALL WEIGHTS UP TO THE MAXIMUM SHOWN.
3. STRUCTURAL ENGINEER OF RECORD (SEOR) FOR THE BUILDING SHALL PROVIDE SUPPORT STRUCTURE DESIGNED TO SUPPORT WEIGHTS AND FORCES SHOWN IN COMBINATION WITH ALL OTHER LOADS TO BE PRESENT.
4. STRUCTURAL ENGINEER OF RECORD FOR THE BUILDING SHALL VERIFY THAT INSTALLATION IS IN CONFORMANCE WITH THE CBC 2016 AND WITH THE DETAILS SHOWN IN THIS PREAPPROVAL AND SHALL VERIFY THAT THE ACTUAL EQUIPMENT WEIGHT, CENTER OF GRAVITY, LOCATION, ATTACHMENT LOCATIONS, ATTACHMENT DETAILS, AND MATERIAL AND THICKNESS OF THE UNIT WHERE THE ATTACHMENTS ARE MADE AGREE WITH THE INFORMATION CONTAINED IN THE PREAPPROVAL DOCUMENTS.
5. CONTRACTOR SHALL BE RESPONSIBLE TO VERIFY THAT FASTENERS & INSTALLATION IS IN CONFORMANCE WITH THE CBC 2016 AND WITH THE DETAILS SHOWN IN THIS PREAPPROVAL.

MAXIMUM DESIGN DEMANDS

(LOADS ARE AT LRFD PER BOLT)

ARMS EXTENDED AWAY FROM WALL

$V_u = 84$ LBS/BOLT
 $T_u = 1,070$ LBS/BOLT

ARMS EXTENDED PARALLEL TO THE WALL

$V_u = 210$ LBS/BOLT
 $T_u = 886$ LBS/BOLT

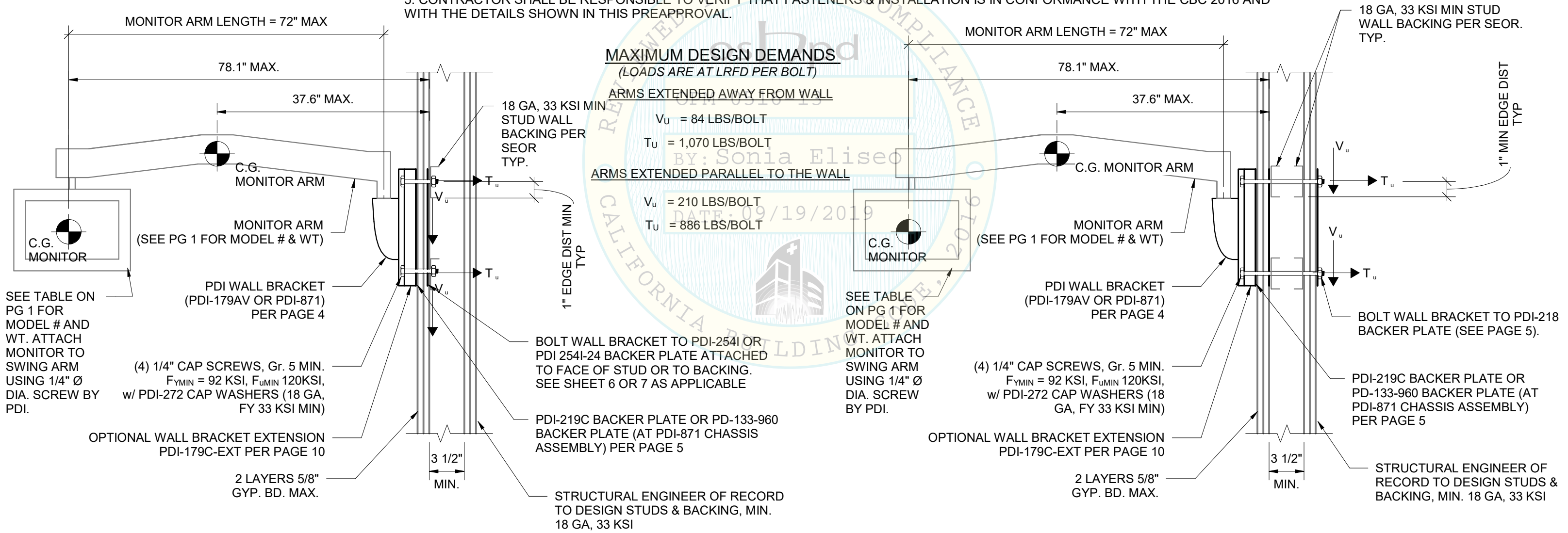

OPTION 1 - STEEL STUD WALL SECTION

MAX . C.G. OF THE (3) SWING ARM MODELS

OPTION 2 - STEEL STUD WALL SECTION

MAX . C.G. OF THE (3) SWING ARM MODELS



OSHPD PRE-APPROVAL OF MANUFACTURER'S CERTIFICATION

OPM-0516-13

PDi COMMUNICATION SYSTEMS INC.

DEGENKOLB ENGINEERS
1300 Clay Street, Suite 900
Oakland, CA 94612
510.272.9040 PHONE
510.272.5926 FAX



ARTICULATING SWING ARM MODELS

PDI-AA-500
PDI-AA-1000
PDI-AA-1400

PDI MONITOR MODELS

P14W MEDTV16
P14T2 MEDTAB16
P19A/T/S/C

WALL MOUNT BRACKET MODELS

PDI-179AV
PDI-871

FLOOR MOUNT BASE PLATE MODELS

PDI-886BASE
PDI-886BASE-W

CASE 2 ($z/h \leq 1.0$)
 $S_{DS} \leq 2.5$

SEISMIC SUPPORTS & ATTACHEMENTS

BACK TO BACK WALL-MOUNTED

SHEET NOTES:

1. FOR DESIGN FORCES AND FACTORS SEE GENERAL NOTES ON PAGE 1.
2. THIS PREAPPROVAL ENCOMPASSES ALL WEIGHTS UP TO THE MAXIMUM SHOWN.
3. STRUCTURAL ENGINEER OF RECORD (SEOR) FOR THE BUILDING SHALL PROVIDE SUPPORT STRUCTURE DESIGNED TO SUPPORT WEIGHTS AND FORCES SHOWN IN COMBINATION WITH ALL OTHER LOADS TO BE PRESENT.
4. STRUCTURAL ENGINEER OF RECORD FOR THE BUILDING SHALL VERIFY THAT INSTALLATION IS IN CONFORMANCE WITH THE CBC 2016 AND WITH THE DETAILS SHOWN IN THIS PREAPPROVAL AND SHALL VERIFY THAT THE ACTUAL EQUIPMENT WEIGHT, CENTER OF GRAVITY, LOCATION, ATTACHMENT LOCATIONS, ATTACHMENT DETAILS, AND MATERIAL AND THICKNESS OF THE UNIT WHERE THE ATTACHMENTS ARE MADE AGREE WITH THE INFORMATION CONTAINED IN THE PREAPPROVAL DOCUMENTS.
5. CONTRACTOR SHALL BE RESPONSIBLE TO VERIFY THAT FASTENERS & INSTALLATION IS IN CONFORMANCE WITH THE CBC 2016 AND WITH THE DETAILS SHOWN IN THIS PREAPPROVAL.

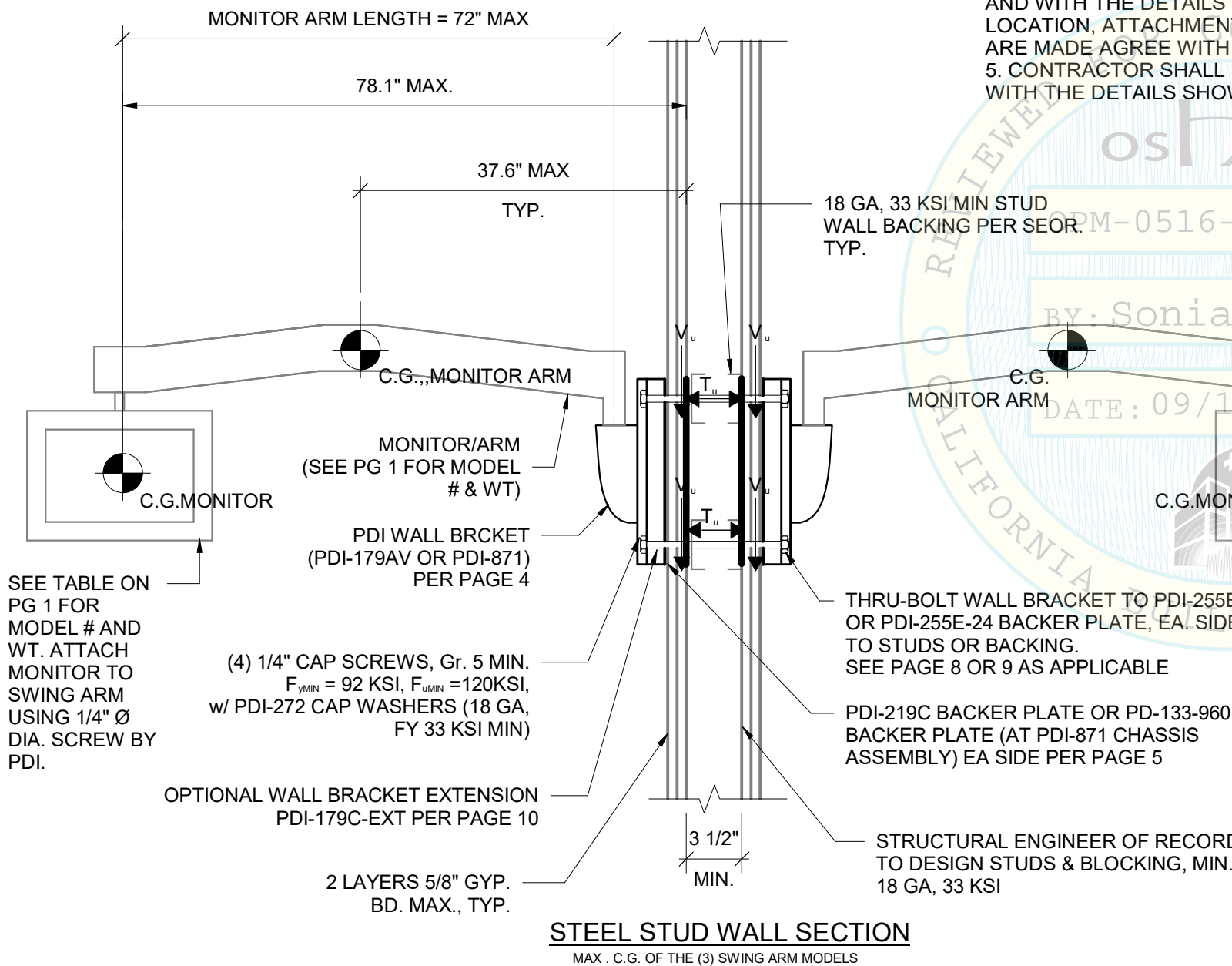

MAXIMUM DESIGN DEMANDS

ARMS EXTENDED AWAY FROM WALL

$V_u = 75$ LBS/BOLT

$T_u = 2,030$ LBS/BOLT

ARMS EXTENDED PARALLEL TO THE WALL

$V_u = 200$ LBS/BOLT

$T_u = 1,628$ LBS/BOLT

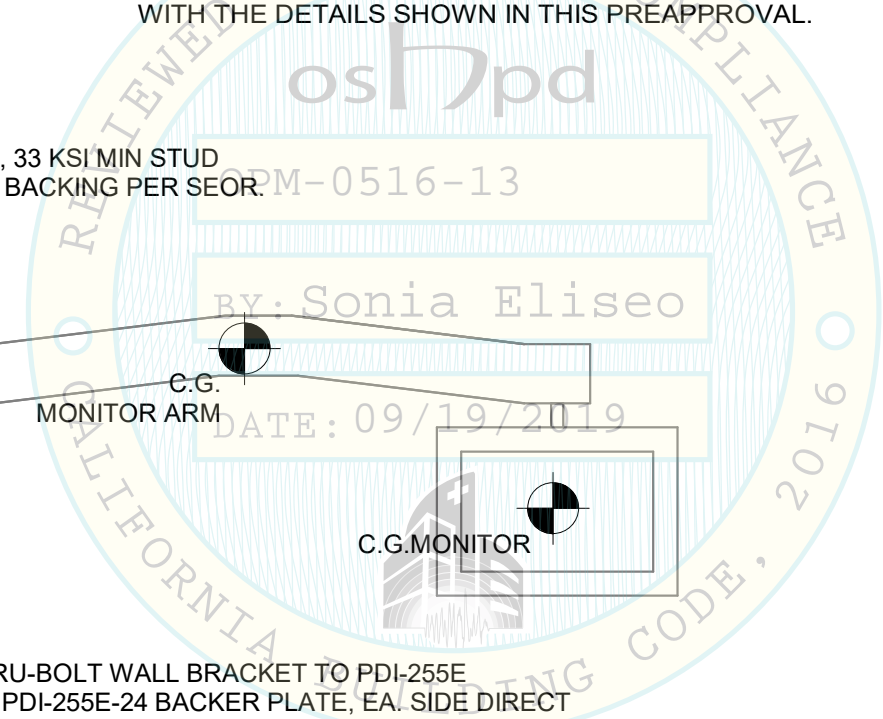

ARTICULATING SWING ARM MODELS

PDI-AA-500
PDI-AA-1000
PDI-AA-1400

PDI MONITOR MODELS

P14W MEDTV16
P14T2 MEDTAB16
P19A/T/S/C

WALL MOUNT BRACKET MODELS

PDI-179AV
PDI-871

FLOOR MOUNT BASE PLATE MODELS

PDI-886BASE
PDI-886BASE-W

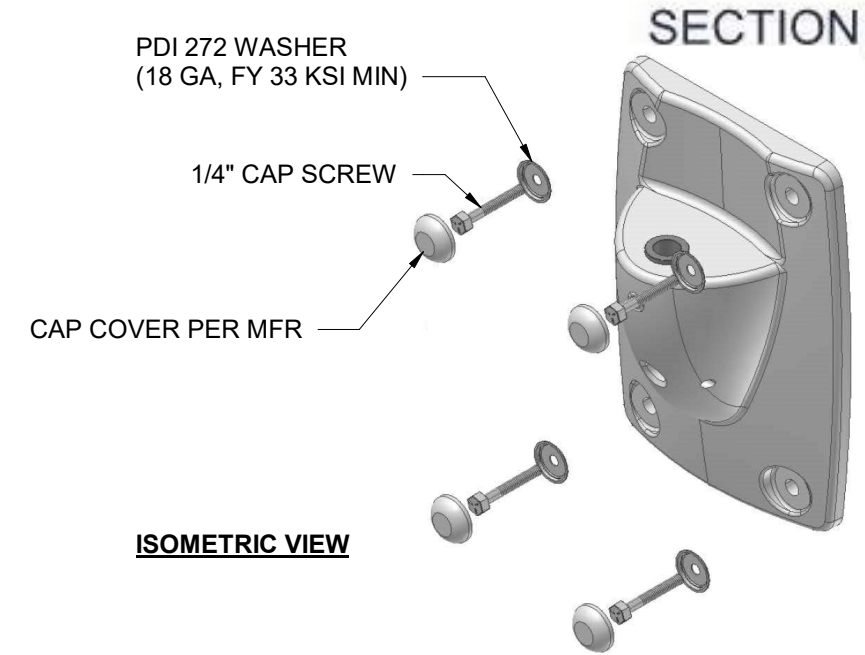
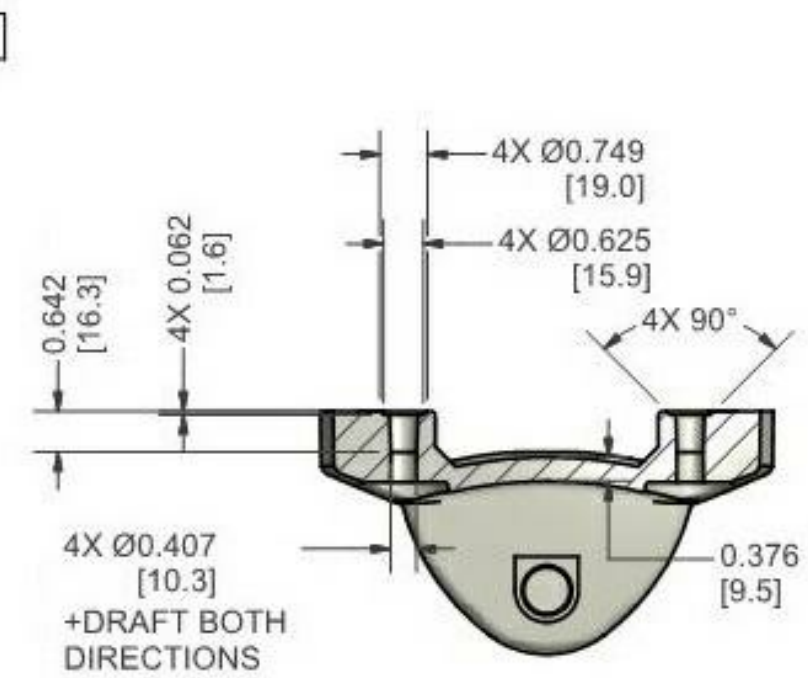
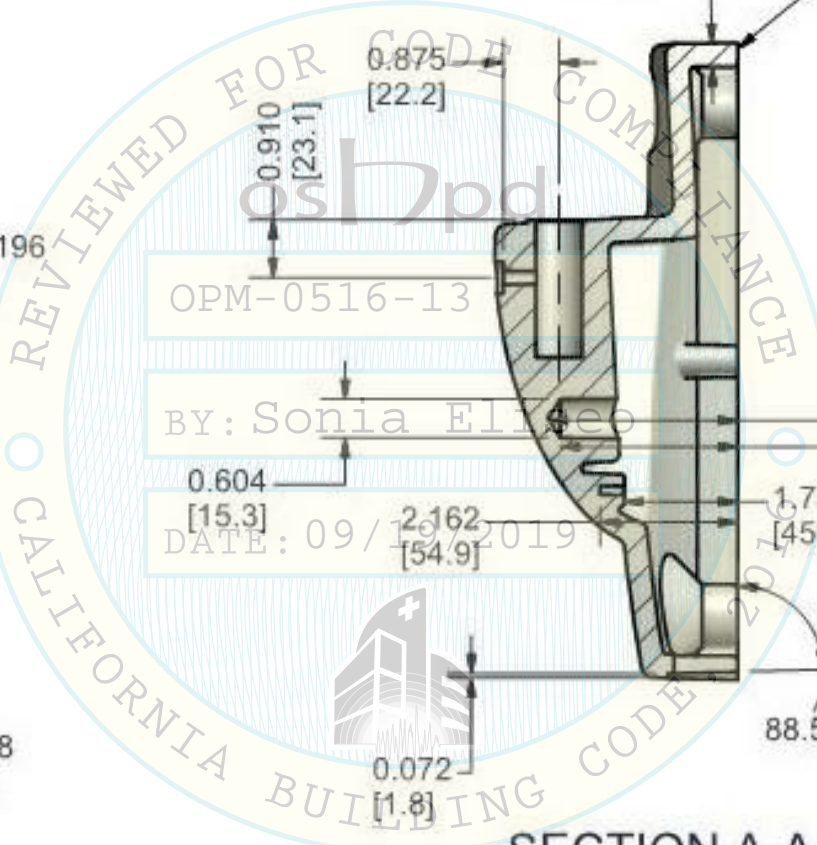
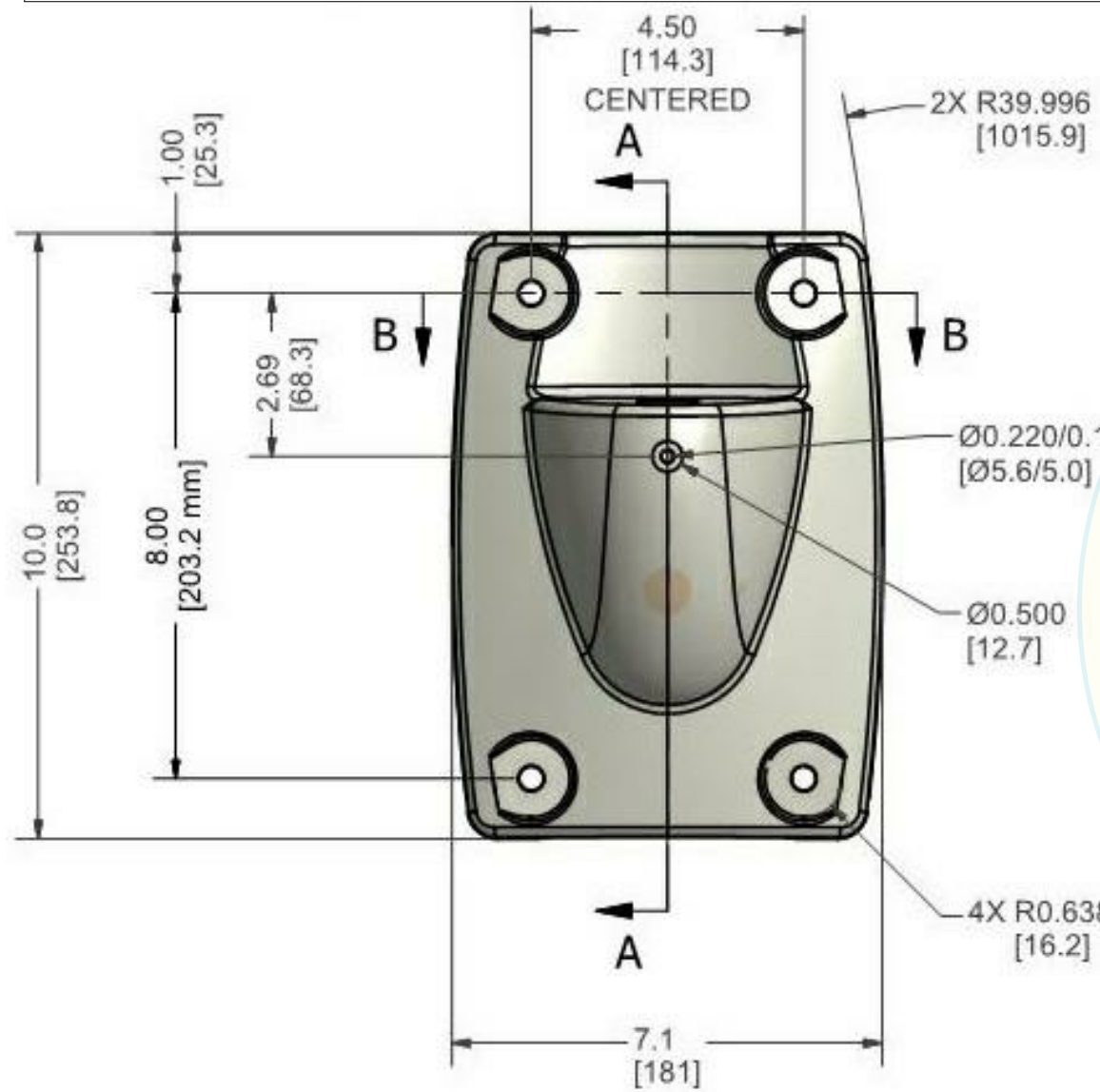

PDI-179AV / PDI-871 WALL MOUNT BRACKET
MATERIAL ADC 12 ALUMINUM (Fy = 24 KSI MIN)
THICKNESS 1/4" MIN
DIMENSIONS ARE IN INCHES
DIMENSIONS SHOWN WITHIN BRACKETS ARE IN MM

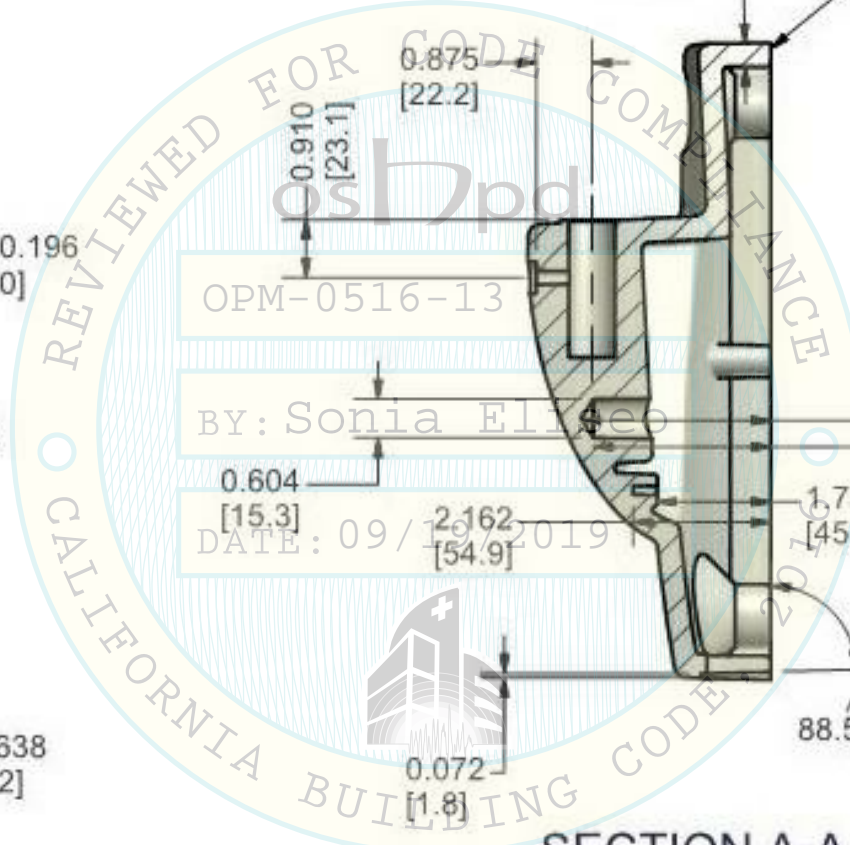



OSHPD PRE-APPROVAL OF MANUFACTURER'S CERTIFICATION

OPM-0516-13

PDi COMMUNICATION SYSTEMS INC.

DEGENKOLB ENGINEERS
1300 Clay Street, Suite 900
Oakland, CA 94612
510.272.9040 PHONE
510.272.5926 FAX



ARTICULATING SWING ARM MODELS

PDI-AA-500
PDI-AA-1000
PDI-AA-1400

PDI MONITOR MODELS

P14W MEDTV16
P14T2 MEDTAB16
P19A/T/S/C

WALL MOUNT BRACKET MODELS

PDI-179AV
PDI-871

FLOOR MOUNT BASE PLATE MODELS

PDI-886BASE
PDI-886BASE-W

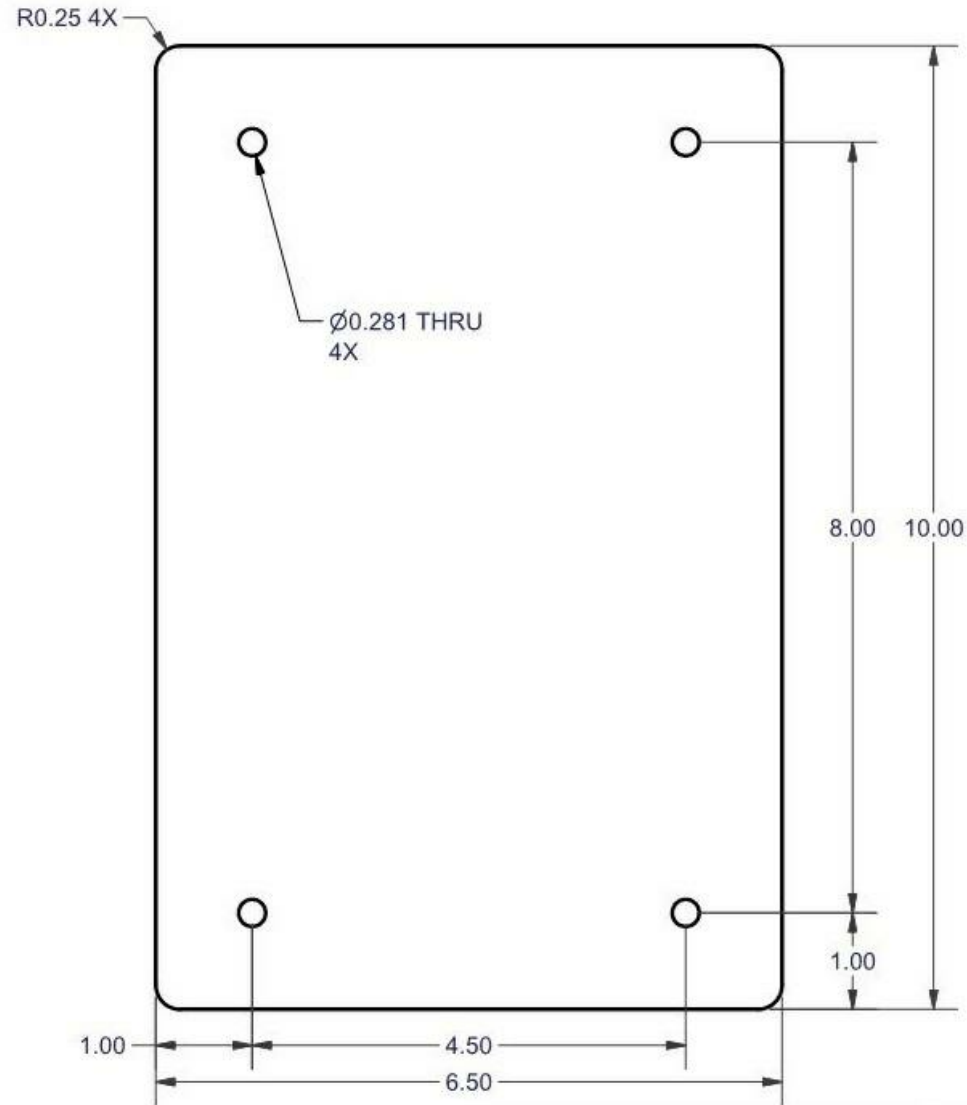

PDI-218 BACKER PLATE

MATERIAL A-1008 CS GRADE B (Fy = 24 KSI MIN)

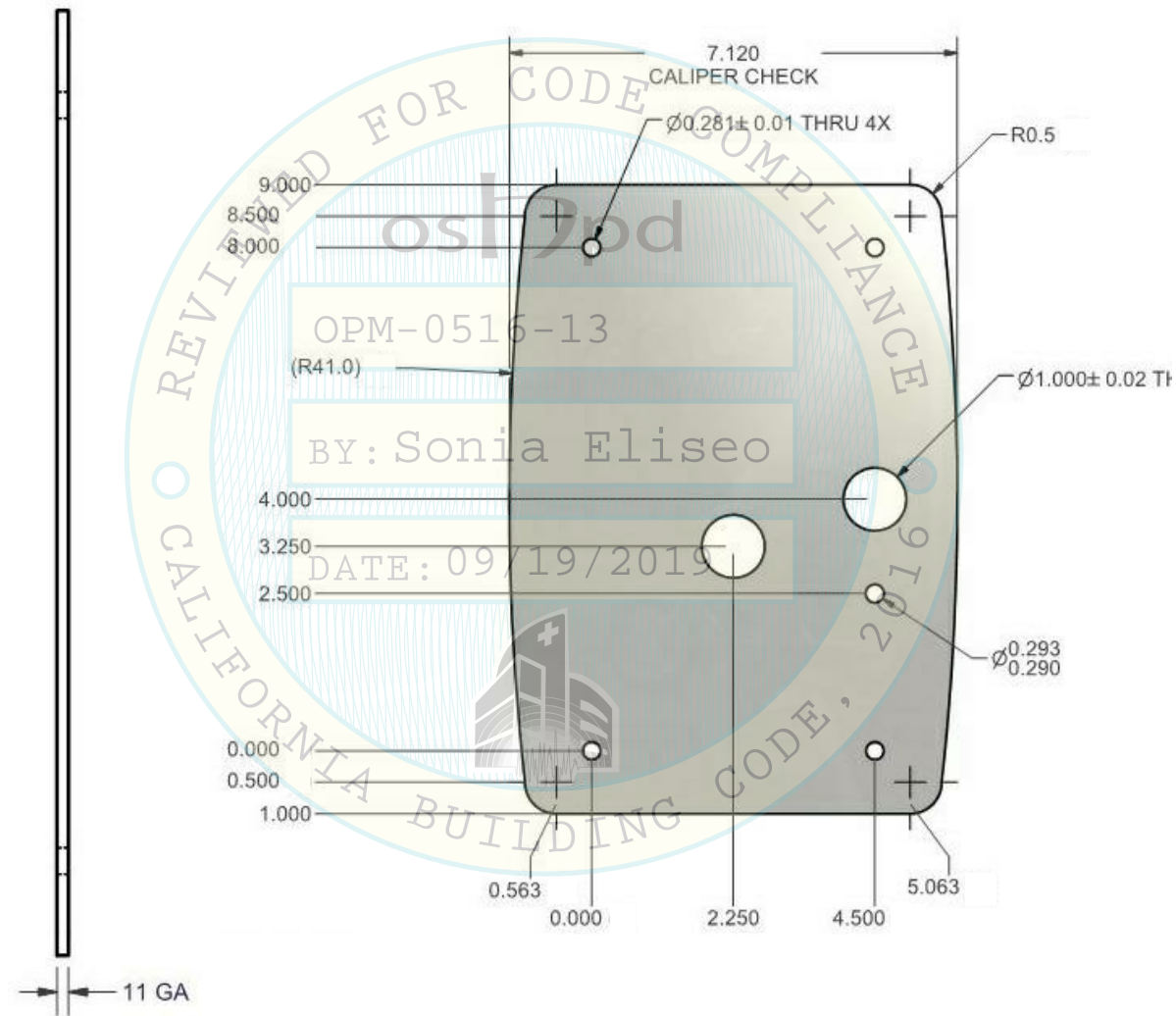

PDI-219C BACKER PLATE

MATERIAL A-1008 CS GRADE B (Fy = 24 KSI MIN)
THICKNESS 11 GA
DIMENSIONS ARE IN INCHES

Hole Table			
HOLE	XDIM	YDIM	DESCRIPTION
B1	-2.250	2.015	Ø0.344
B2	2.250	2.015	
B3	-2.250	10.015	
B4	2.250	10.015	

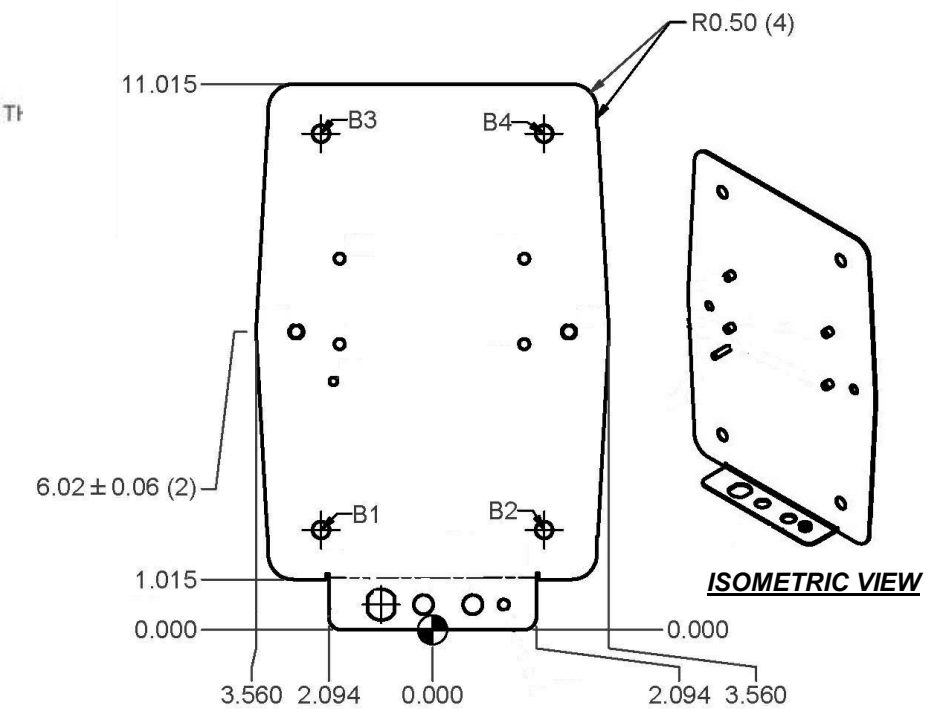

PD133-960 BACKER PLATE

MATERIAL A-1008 CS GRADE B (Fy = 24 KSI MIN)
THICKNESS 18 GA
DIMENSIONS ARE IN INCHES

ARTICULATING SWING ARM MODELS

PDI-AA-500
 PDI-AA-1000
 PDI-AA-1400

PDI MONITOR MODELS

P14W MEDTV16
 P14T2 MEDTAB16
 P19A/T/S/C

FLOOR MOUNT BASE PLATE MODELS

PDI-886BASE
 PDI-886BASE-W

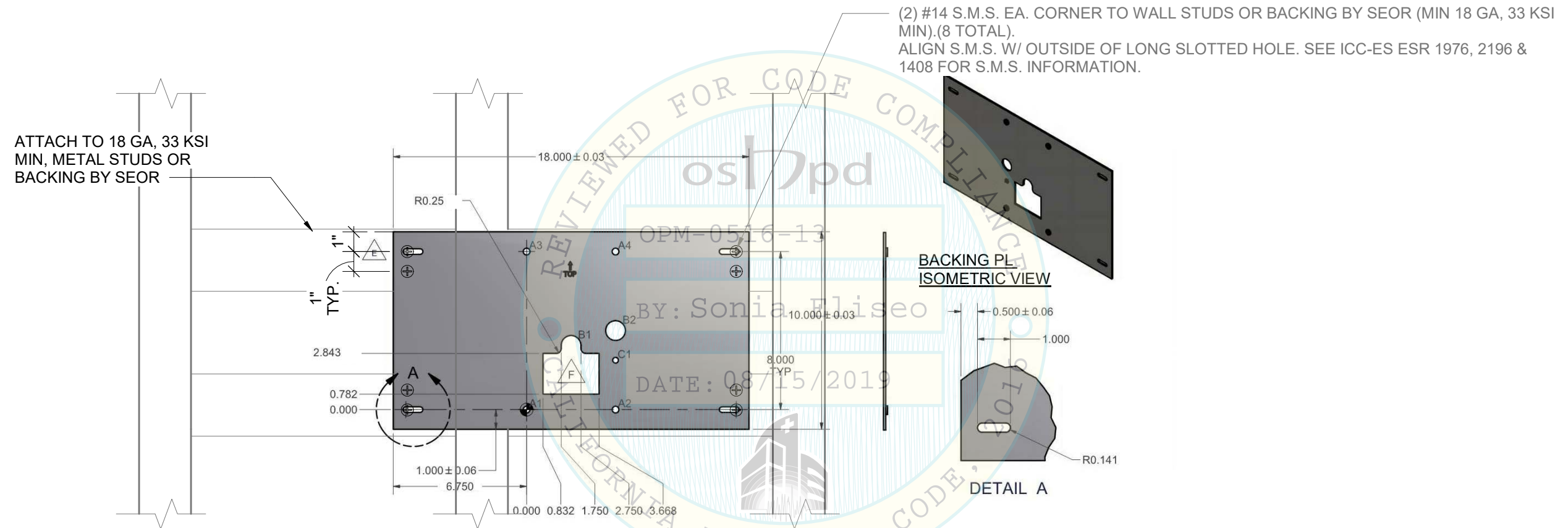

Hole Table			
HOLE	XDIM	YDIM	DESCRIPTION
A1	0.00	0.00	∅ 0.347 ∅ 0.344
A2	4.50	0.00	∅ 0.347 ∅ 0.344
A3	0.00	8.00	∅ 0.347 ∅ 0.344
A4	4.50	8.00	∅ 0.347 ∅ 0.344
B1	2.25	3.25	∅1.0
B2	4.50	4.00	∅1.0
C1	4.50	2.50	∅ 0.293 ∅ 0.290

PDI-254I BACKING PL
 MATERIAL ASTM A653 GR. 33 (Fy = 33 KSI MIN)
 THICKNESS 11 GA
 DIMENSIONS ARE IN INCHES

ARTICULATING SWING ARM MODELS

PDI-AA-500
PDI-AA-1000
PDI-AA-1400

PDI MONITOR MODELS

P14W MEDTV16
P14T2 MEDTAB16
P19A/T/S/C

FLOOR MOUNT BASE PLATE MODELS

PDI-886BASE
PDI-886BASE-W

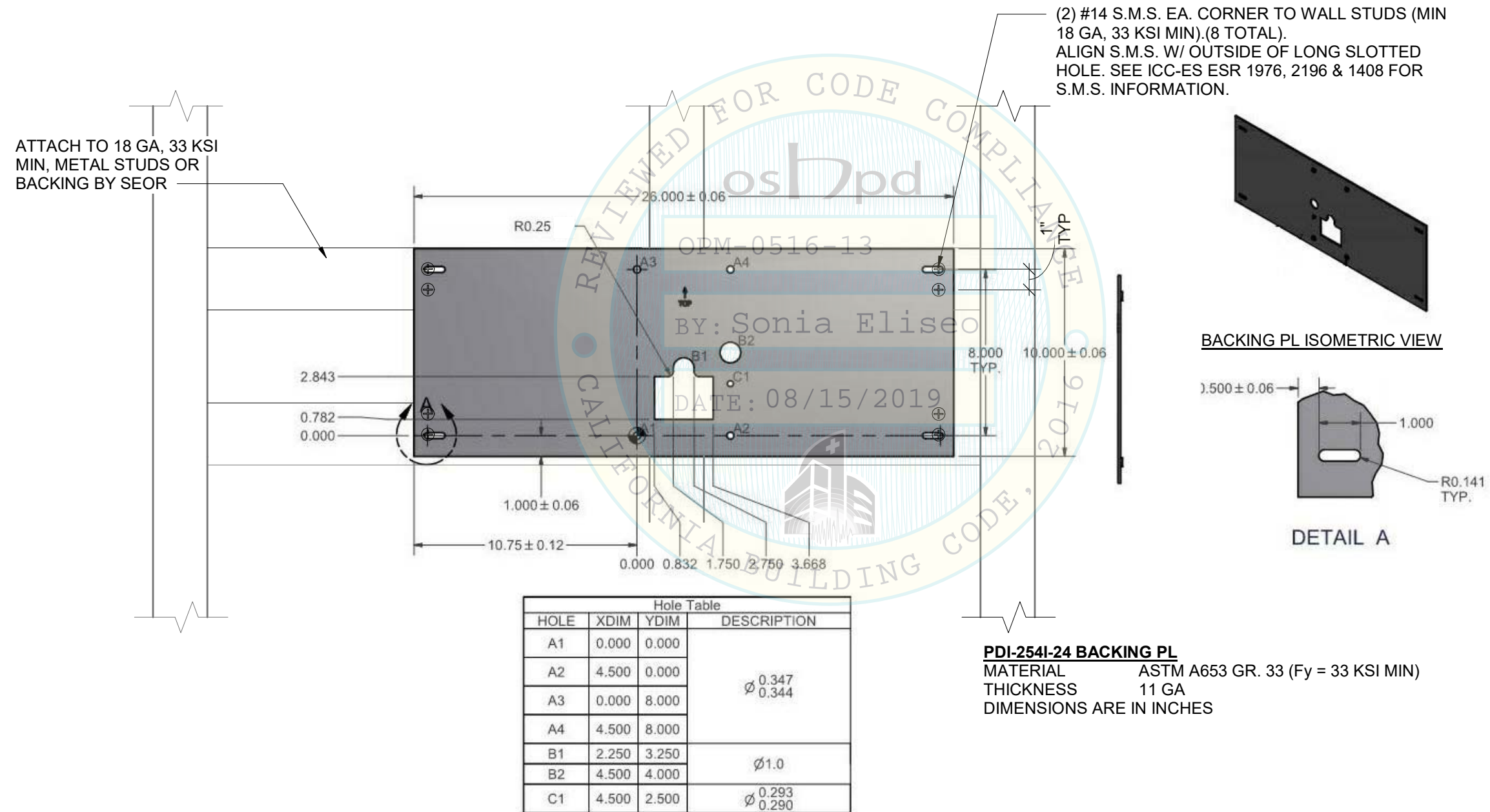

ARTICULATING SWING ARM MODELS

PDI-AA-500
PDI-AA-1000
PDI-AA-1400

PDI MONITOR MODELS

P14W MEDTV16
P14T2 MEDTAB16
P19A/T/S/C

FLOOR MOUNT BASE PLATE MODELS

PDI-886BASE
PDI-886BASE-W

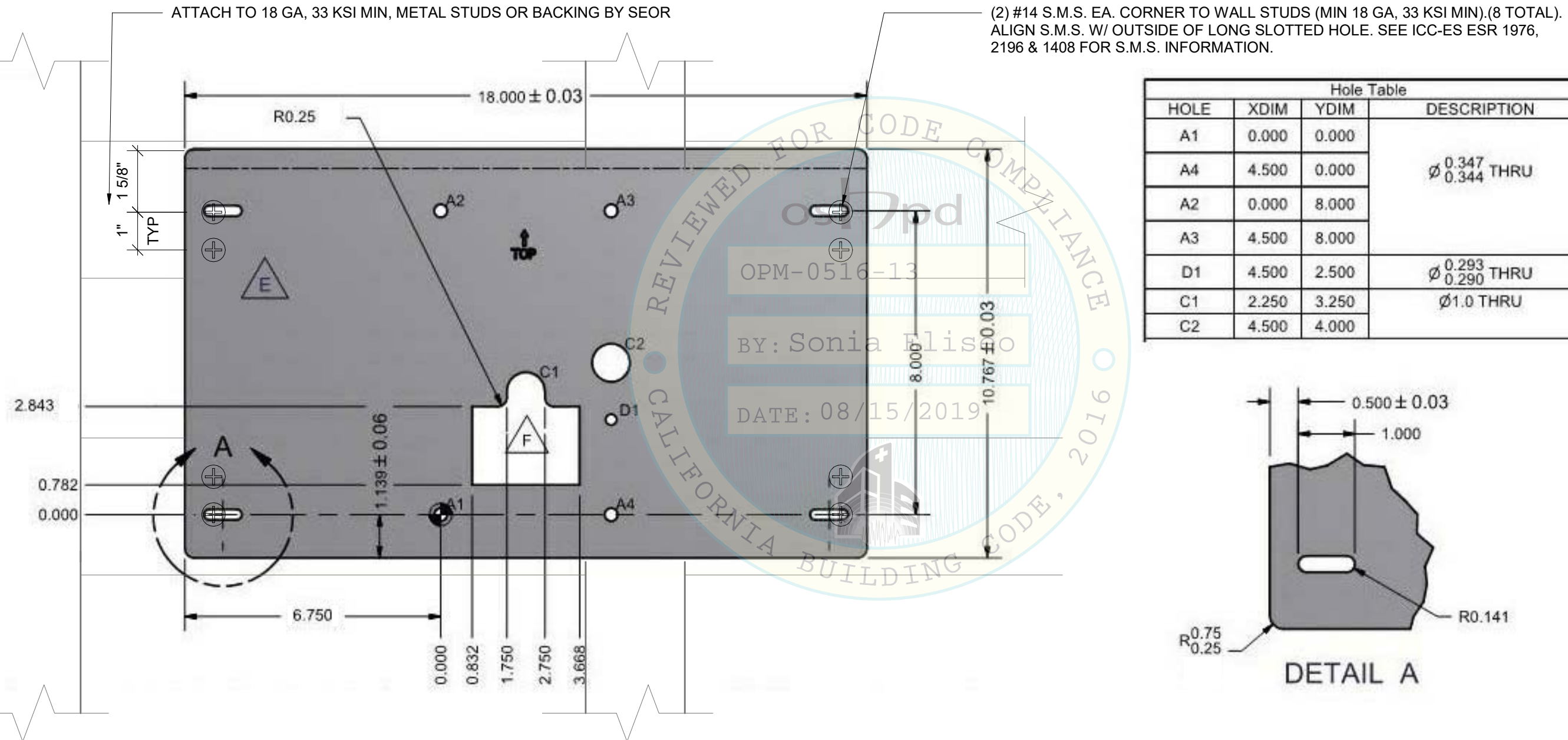

Hole Table			
HOLE	XDIM	YDIM	DESCRIPTION
A1	0.000	0.000	Ø 0.347 0.344 THRU
A4	4.500	0.000	
A2	0.000	8.000	
A3	4.500	8.000	
D1	4.500	2.500	Ø 0.293 0.290 THRU
C1	2.250	3.250	Ø1.0 THRU
C2	4.500	4.000	

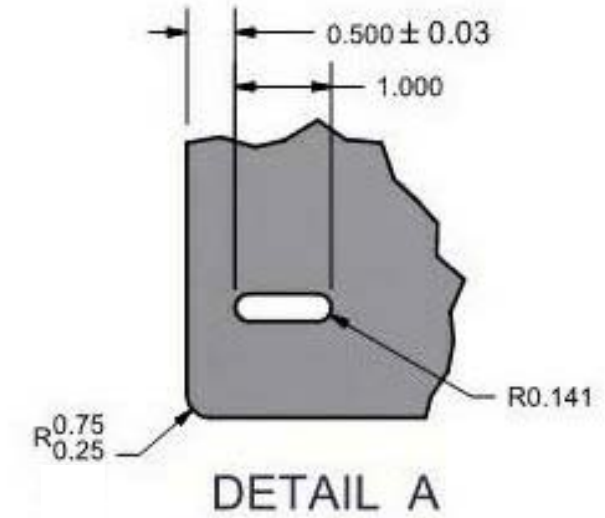

PDI-255E BACKING PL

MATERIAL A-1008 CS GRADE B (Fy = 24 KSI MIN)
THICKNESS 11 GA
DIMENSIONS ARE IN INCHES

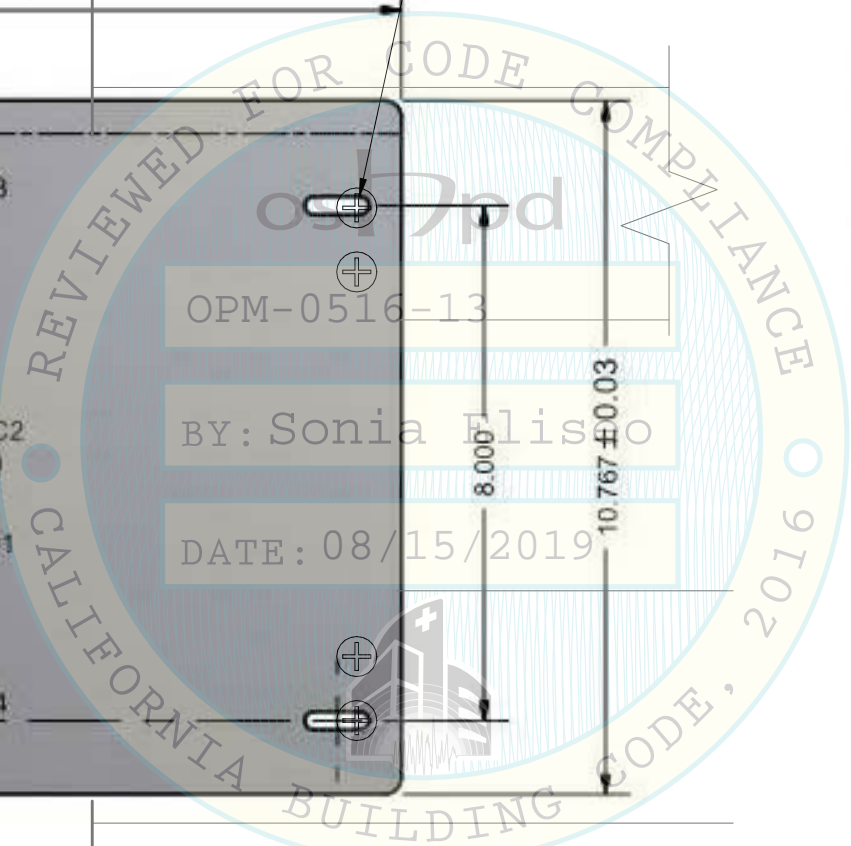

ARTICULATING SWING ARM MODELS

PDI-AA-500
PDI-AA-1000
PDI-AA-1400

PDI MONITOR MODELS

P14W MEDTV16
P14T2 MEDTAB16
P19A/T/S/C

FLOOR MOUNT BASE PLATE MODELS

PDI-886BASE
PDI-886BASE-W

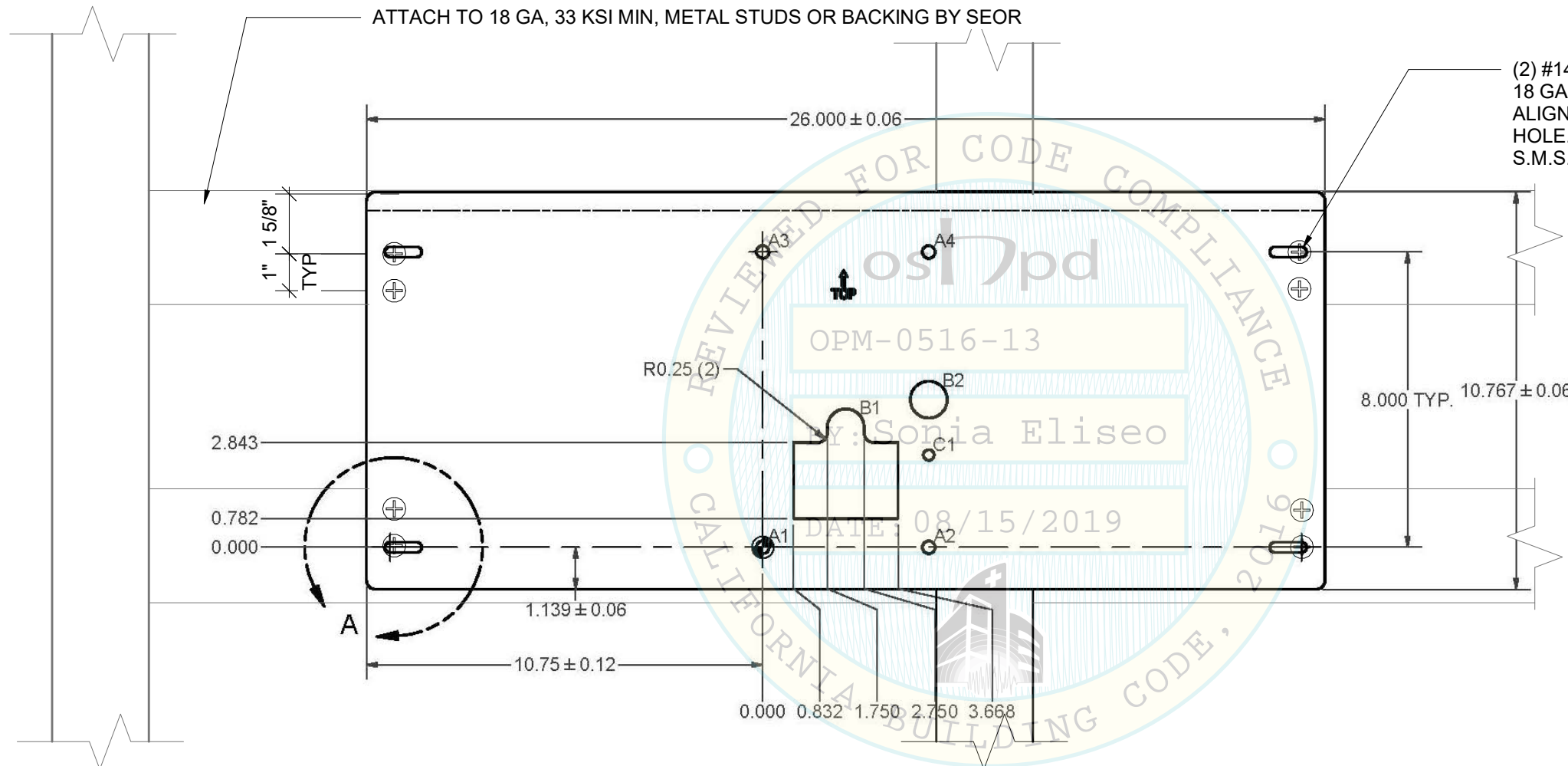

(2) #14 S.M.S. EA. CORNER TO WALL STUDS (MIN 18 GA, 33 KSI MIN).(8 TOTAL). ALIGN S.M.S. W/ OUTSIDE OF LONG SLOTTED HOLE. SEE ICC-ES ESR 1976, 2196 & 1408 FOR S.M.S. INFORMATION.

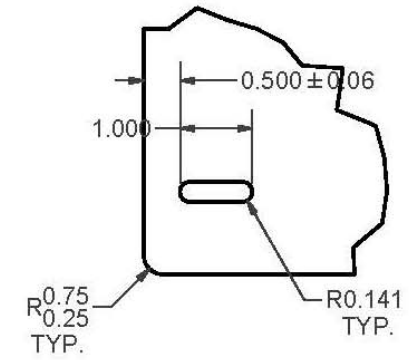

DETAIL A

BACKING PL ISOMETRIC VIEW

Hole Table			
HOLE	XDIM	YDIM	DESCRIPTION
A1	0.000	0.000	Ø 0.347 Ø 0.344 THRU
A2	4.500	0.000	
A3	0.000	8.000	
A4	4.500	8.000	
B1	2.250	3.250	Ø1.0 THRU
B2	4.500	4.000	
C1	4.500	2.500	Ø 0.293 Ø 0.290

PDI-255E-24-B-C-G BACKING PL
MATERIAL A-1008 CS GRADE B (Fy = 24 KSI MIN)
THICKNESS 11 GA
DIMENSIONS ARE IN INCHES

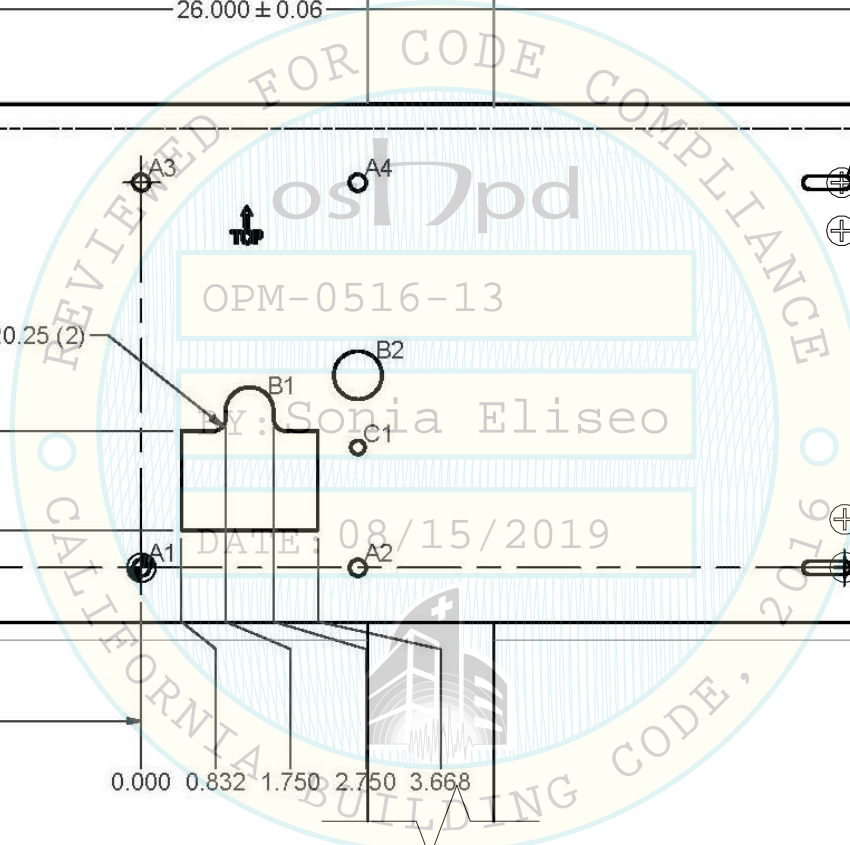



OSHPD PRE-APPROVAL OF MANUFACTURER'S CERTIFICATION

OPM-0516-13

PDi COMMUNICATION SYSTEMS INC.

DEGENKOLB ENGINEERS
1300 Clay Street, Suite 900
Oakland, CA 94612
510.272.9040 PHONE
510.272.5926 FAX



ARTICULATING SWING ARM MODELS

PDI-AA-500
PDI-AA-1000
PDI-AA-1400

PDI MONITOR MODELS

P14W MEDTV16
P14T2 MEDTAB16
P19A/T/S/C

FLOOR MOUNT BASE PLATE MODELS

PDI-886BASE
PDI-886BASE-W

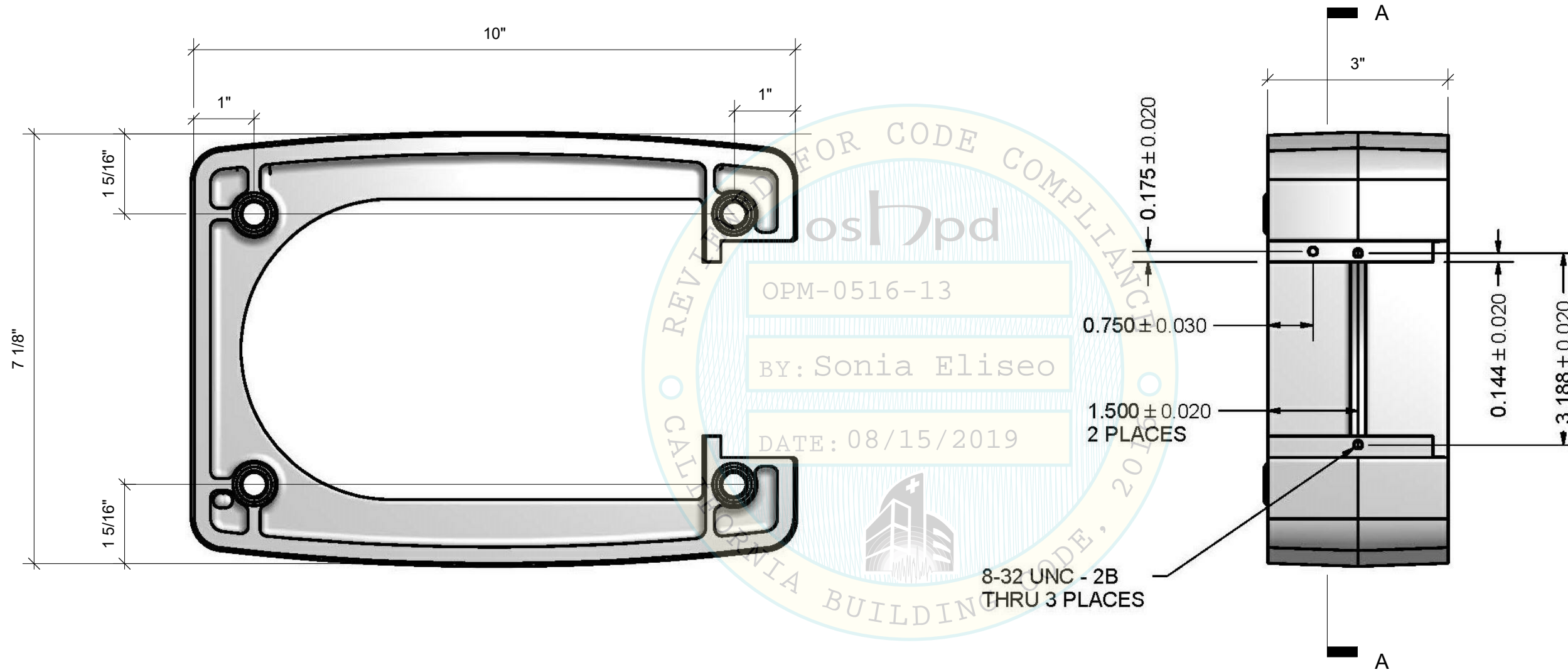

SECTION A-A

TOP VIEW

PDI-179C-EXT

MATERIAL ADC 12 ALUMINUM (Fy = 24 KSI MIN)
DIMENSIONS ARE IN INCHES

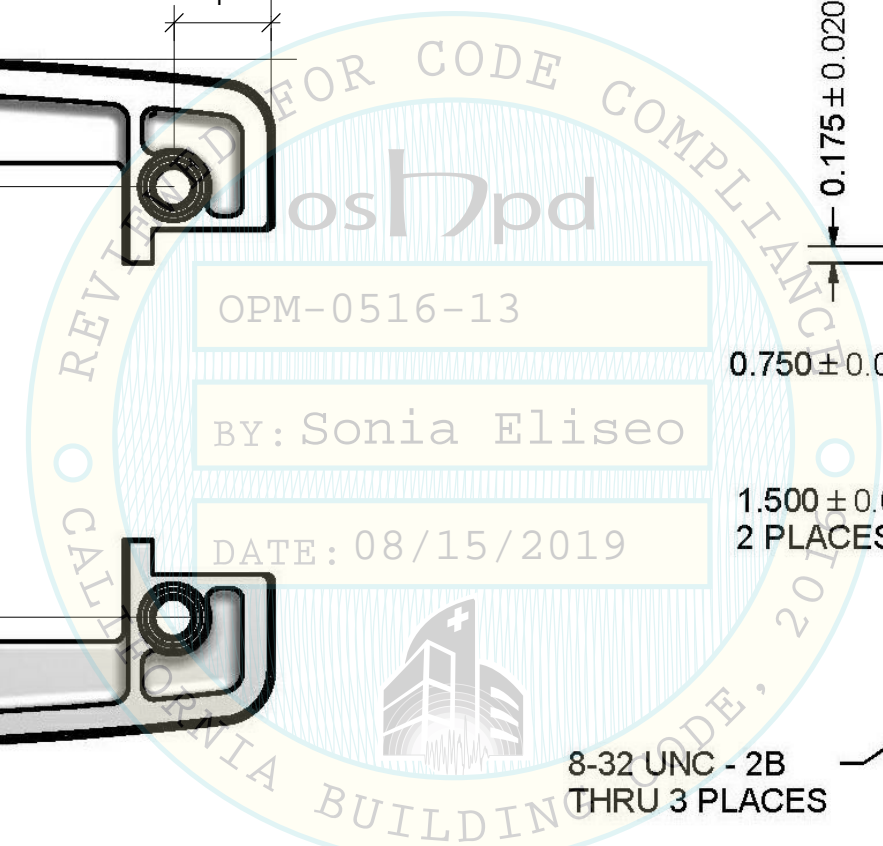

ARTICULATING SWING ARM MODELS

PDI-AA-500
PDI-AA-1000
PDI-AA-1400

PDI MONITOR MODELS

P14W MEDTV16
P14T2 MEDTAB16
P19A/T/S/C

FLOOR MOUNT BASE PLATE MODELS

PDI-886BASE
PDI-886BASE-W

CASE 3 ($z/h = 0.0$)
 $S_{Ds} \leq 1.8$

FLOOR MOUNT ON GRADE
BASE PL MODEL PDI-886BASE

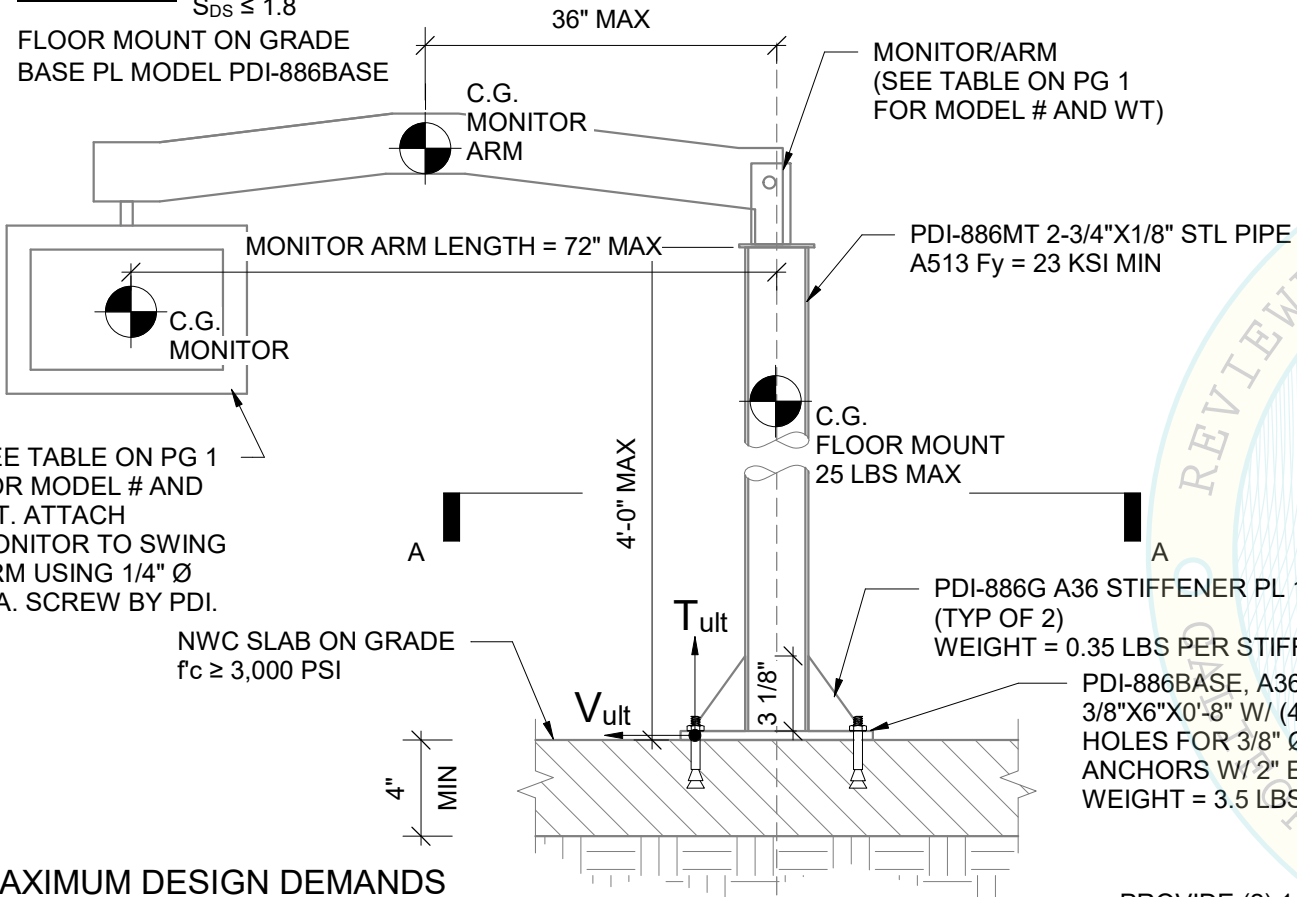

SIDE ELEVATION

$V_u = 15 \text{ LBS/ANCHOR}$

$T_u = 505 \text{ LBS/ANCHOR}$

NOTE THAT THESE DEMANDS ARE PER EXPANSION ANCHOR AND HAVE **NOT** BEEN AMPLIFIED BY Ω_o

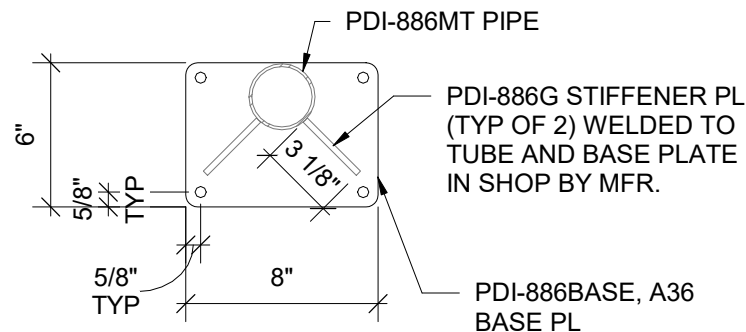

SECTION A-A

CASE 4 ($z/h \leq 1.0$)
 $S_{Ds} \leq 2.5$

FLOOR MOUNT ON ELEVATED SLAB
BASE PL MODEL PDI-886BASE

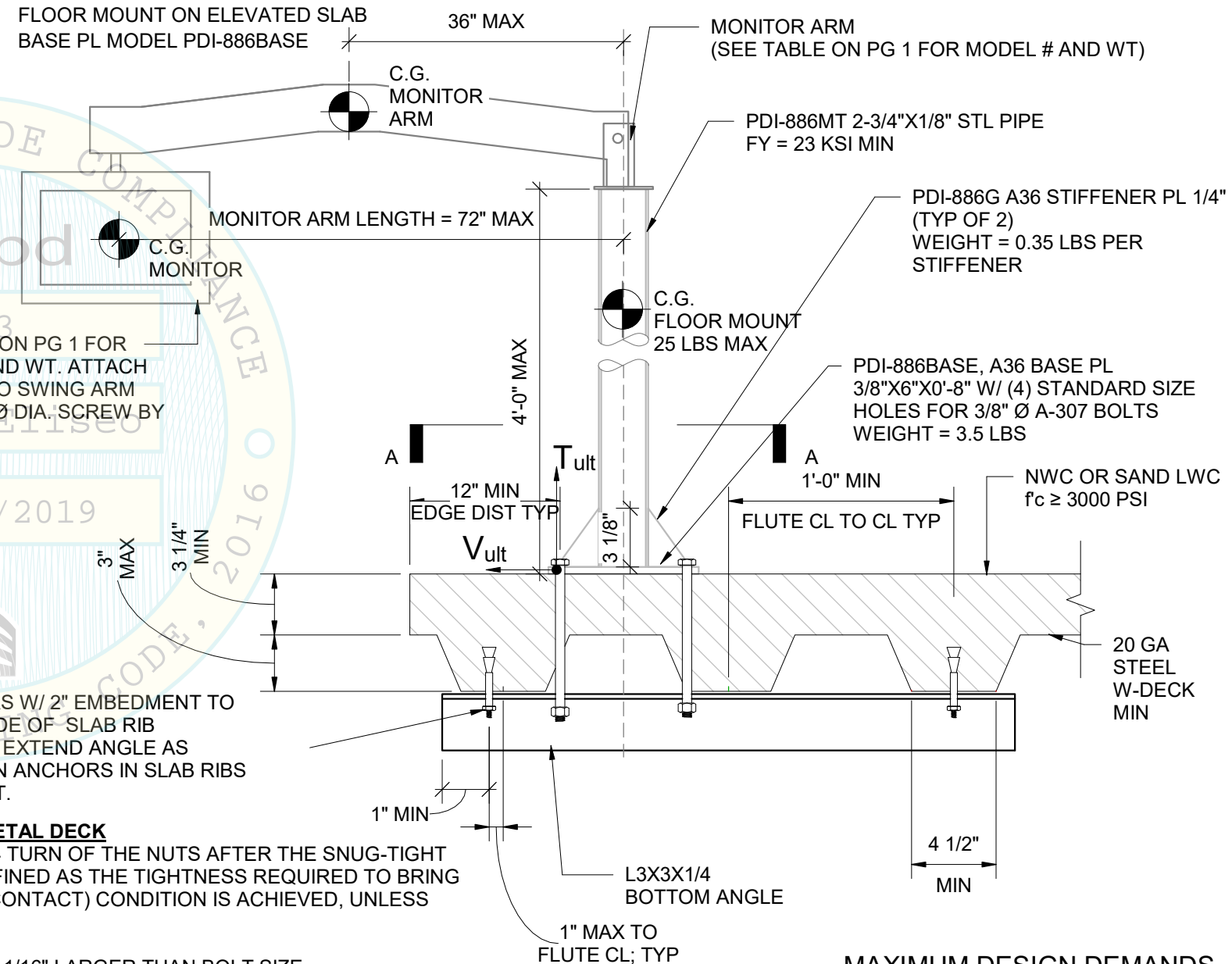

SIDE ELEVATION

MAXIMUM DESIGN DEMANDS

$V_u = 65 \text{ LBS/BOLT}$

$T_u = 1,602 \text{ LBS/BOLT}$

NOTE THAT THESE DEMANDS ARE PER BOLT AND HAVE **NOT** BEEN AMPLIFIED BY Ω_o

PROVIDE (2) 1/2" \varnothing EXPANSION ANCHORS W/ 2" EMBEDMENT TO SUPPORT ANGLE. INSTALL AT UNDERSIDE OF SLAB RIB INDEPENDENT FROM THROUGH BOLTS. EXTEND ANGLE AS REQUIRED. DO NOT INSTALL EXPANSION ANCHORS IN SLAB RIBS WHERE THROUGH BOLTS ARE PRESENT.

BOLTS THROUGH CONCRETE ON METAL DECK

A. BOLTS SHALL BE TORQUED BY 3/4 TURN OF THE NUTS AFTER THE SNUG-TIGHT (THE SNUG-TIGHT CONDITION IS DEFINED AS THE TIGHTNESS REQUIRED TO BRING THE CONNECTED PLIES INTO FIRM CONTACT) CONDITION IS ACHIEVED, UNLESS OTHERWISE NOTED.

B. THROUGH BOLT HOLES SHALL BE 1/16" LARGER THAN BOLT SIZE (HOLE SIZE = BOLT SIZE + 1/16") FOR CONCRETE.

C. THROUGH-BOLTS IN CONCRETE SHALL RECEIVE SPECIAL INSPECTION AND TESTING (THROUGH BOLTS WITH STEEL TO STEEL CONNECTION IN TENSION DO NOT REQUIRE TENSION TESTING) IN ACCORDANCE WITH REQUIREMENTS FOR POST-INSTALLED ANCHORS.

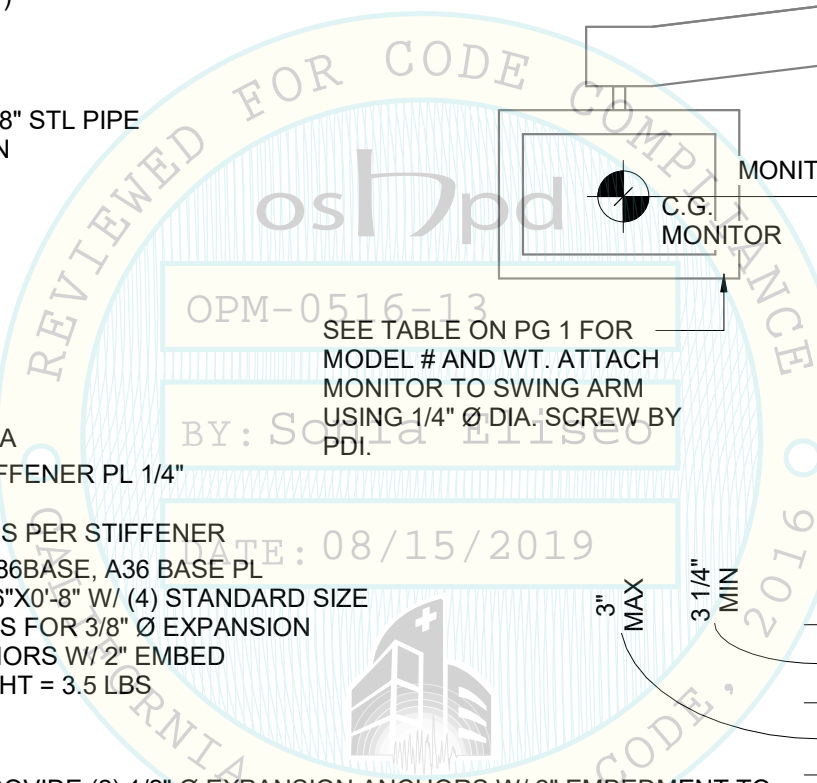

ARTICULATING SWING ARM MODELS

PDI-AA-500
PDI-AA-1000
PDI-AA-1400

PDI MONITOR MODELS

P14W MEDTV16
P14T2 MEDTAB16
P19A/T/S/C

FLOOR MOUNT BASE PLATE MODELS

PDI-886BASE
PDI-886BASE-W

CASE 5 ($z/h = 0$)
 $S_{DS} \leq 2.5$

FLOOR MOUNT ON GRADE
BASE PL MODEL PDI-886BASE-W

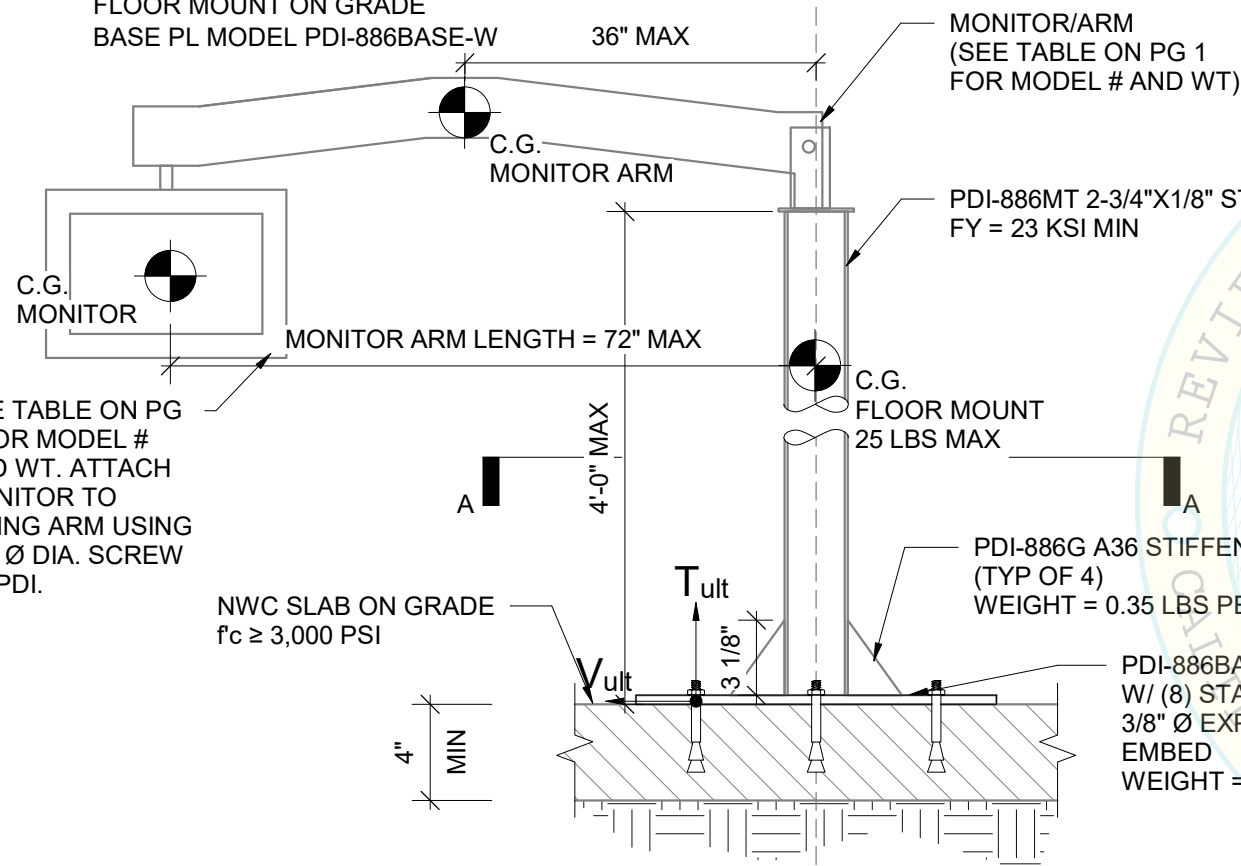

SIDE ELEVATION

CASE 6 ($z/h \leq 0.9$)
 $S_{DS} \leq 2.0$

FLOOR MOUNT ON ELEVATED SLAB
BASE PL MODEL PDI-886BASE-W

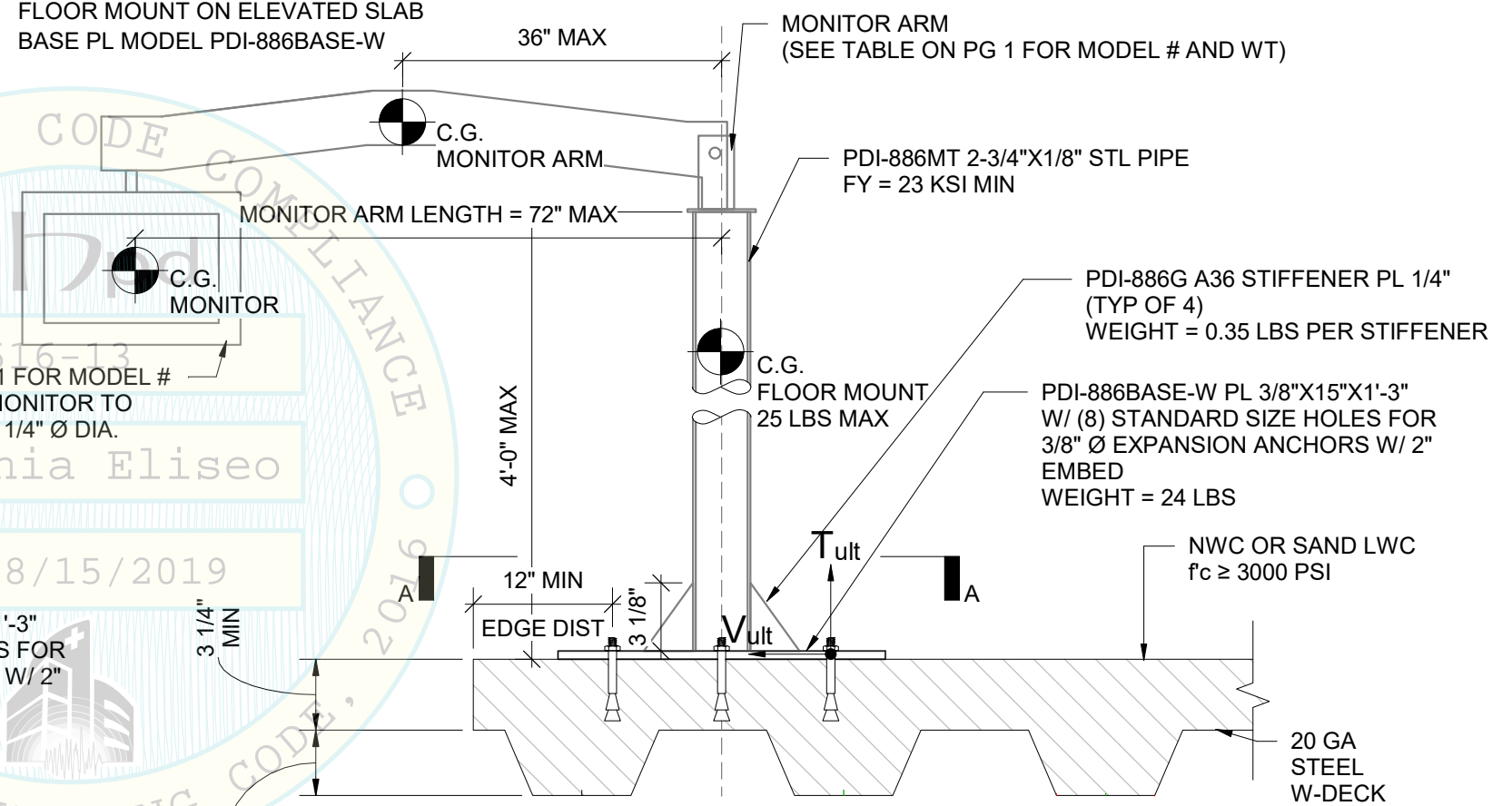

SIDE ELEVATION

MAXIMUM DESIGN DEMANDS

$V_u = 11 \text{ LBS/ANCHOR}$

$T_u = 135 \text{ LBS/ANCHOR}$

NOTE THAT THESE DEMANDS ARE PER EXPANSION ANCHOR AND HAVE **NOT** BEEN AMPLIFIED BY Ω_0

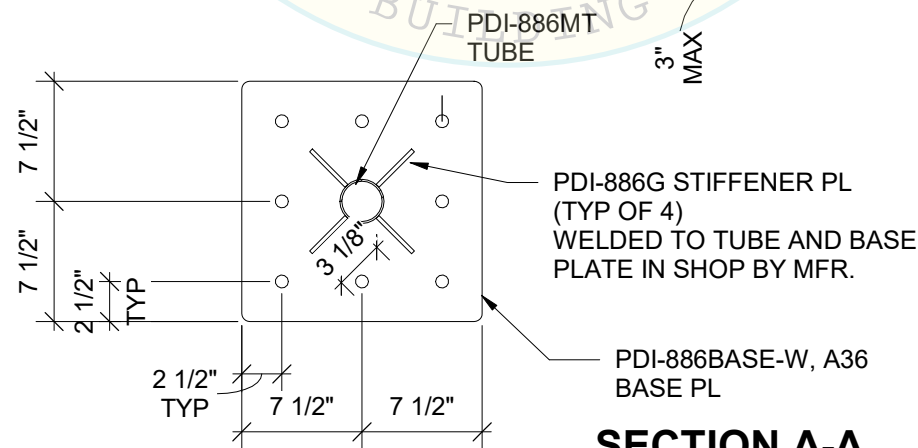

SECTION A-A

MAXIMUM DESIGN DEMANDS

$V_u = 24 \text{ LBS/ANCHOR}$

$T_u = 276 \text{ LBS/ANCHOR}$

NOTE THAT THESE DEMANDS ARE PER EXPANSION ANCHOR AND HAVE **NOT** BEEN AMPLIFIED BY Ω_0

