

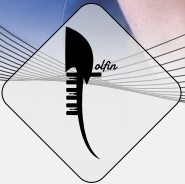

The Proven Patient Infotainment System

medTAB[®]

patient experience on demand



Differentiate your hospital patient engagement experience.

medTAB[®] delivers a personal, touchscreen experience patients easily understand and enjoy



Arm Mounts or VESA

Low-voltage Power over ENET

Easy Clean Glass Front

IPTV

Multi-touch Displays

Front Headphone Jack

Built For Healthcare

Camera/Mic

Preloaded Infotainment

Antimicrobial Plastics

medTAB¹⁶ⁱ

16" PATIENT TV-TABLET

medTAB¹⁹ⁱ

19" PATIENT TV-TABLET

ALL-IN-ONE COMPLETE TOUCHSCREEN SOLUTIONS THAT SATISFY PATIENTS & STAFF

- Everything you need for fully integrated IPTV and interactive patient engagement
- Easy to use 16" and 19" touchscreen IPTV-tablets, equal to a 90" wall TV experience
- Secure access to health records, patient education, and more
- Easily customize to differentiate your patient experience with value-added services
- Securely mounted to PDI arm systems, and continuously powered
- Fun to use yet built for healthcare safety and infection control

The TOUGHEST hardware powered by the SMARTEST software



medTAB with Dolfin Infotainment Software

The latest medTV solutions, powered by Dolfin, deliver the custom experience you desire for a consistent and personalized patient experience. The Dolfin software solution is a highly customizable content management software system (CMS) with IPTV and access to patient services that was created to expand the in-room patient infotainment experience. This easy to use head-end software was built for healthcare and is proven to improve your patient engagement experience.

BENEFITS TO PATIENTS

On-demand entertainment features

- Movies
- Videos
- Music
- Games
- Social Sites

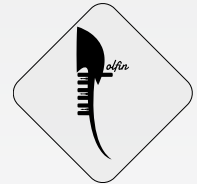

Secure access to hospital IT

- View personal health records
- Access patient education, PACS and EMR
- Easily order meals
- Provide patient feedback
- Environmental room controls for lighting, climate and window blinds
- Prayers and more

Differentiate Your Hospital Patient Engagement Experience



- ✓ Familiar technologies to entertain and satisfy patients
- ✓ Customize your health-IT integrations to deliver personalized care
- ✓ Educate your patients and improve health outcomes

- ✓ Optimize your staff efficiencies and reduce costs
- ✓ Centrally manage terminals and displays over the Ethernet
- ✓ Proven healthcare solutions you can trust by PDi, since 1980

Secure Mounts for Hospitals, Clinics, Senior Living and More

PDi's innovative designs allow devices to mount to headwalls, counters, ceilings, floors, chairs and more.

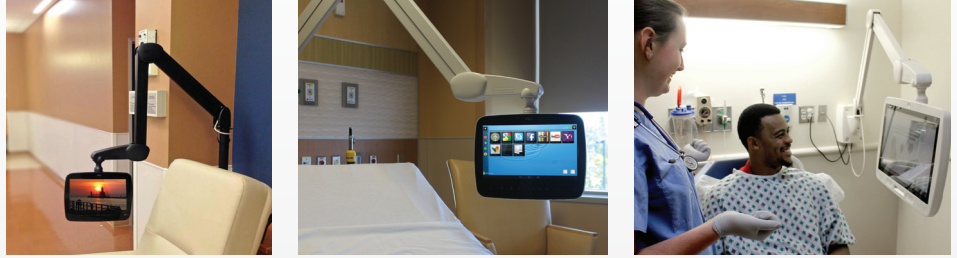

Ohio-based PDi Communication Systems, Inc. designs, manufactures and builds more complete arm-mounted bedside entertainment systems than anyone in the industry.

Allow PDi's engineering and experience to help you build the complete patient entertainment solution for your unique project needs.



68"
Reach

1400 Series Arm

- Reduces back, neck, and eye strain
- A better audio experience
- Secures your device investment
- Intelligent cable management
- UL-Listed & Antimicrobial

"...severe headaches made it difficult for my father to wear his glasses, but the TV swing arm allowed him to pull the television close and alleviate his boredom between visits from family and friends."

- Rich C.

Low-voltage Power Supplies

- Standard XLR Power and Cat6 Ethernet Cables are included with device
- Safe UL-Listed low-voltage power supplies, no batteries needed
- Available Power over Ethernet



Slim Power Mount
PDI-871XL-COLOR

Standard External
Power Supply
PDI-750XL-COLOR



color = B/C/G
where B=Black, C= Cream, G= Starlight Gray

Dimensions (inches)

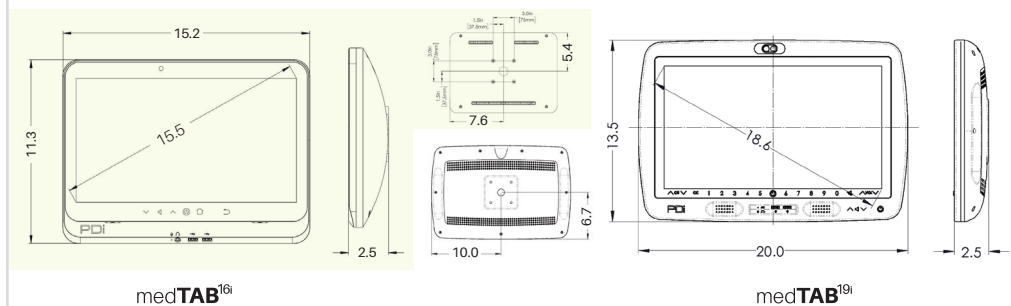

KEY FEATURES



Patient tablet with custom software plus IPTV



Compatible with PDi arms or available as VESA 75 x 75mm mount for mounting in any situation



Customizable software to educate, communicate, entertain and satisfy patients and visitors.



Standard cabinet color is Starlight Gray. Ask about black or cream.



Built by PDi for CE/CB/RoHS healthcare-grade, low voltage safety standards.



Designed, Programmed and Assembled in U.S.A.

For More Information &
How to Buy Contact:

Dr. Mohamed Amer
Regional Sales Manager
+20 100 888 8090
mamer@pdiarm.com

www.pdiarm.com/intentional-healthcare-grade-patient-displays

SPECIFICATIONS

PANEL	PDi-P16A-CWL-D	PDi-P19A-CWL-D
Diagonal Screen Size	15.6"	18.5"
Display Resolution	1920 x 1080	1280 x 720
Luminance	250 nits	300 nits
Backlight Type	LED	
Contrast Ratio	800:1	1000:1

POWER

Source	Power over Coax or Power over Ethernet
Max Consumption	34W

INPUT/OUTPUT

Ethernet	Yes
USB	2, Patient Facing
Internal SD Card	Optional
HDMI	Optional
Speakers	2x2-Watt RMS

REGULATORY

CE/CB	Yes
FCC Title 15, Part 47, Subpart B	Yes
RoHS	Yes

COMPUTER FEATURES

OS	Android 5.1 (Lollipop)
CPU	Arm A9 Quad Core 1.2GHz
WiFi	802.1 a/b/g/n
Ethernet	Yes
Touchscreen	Projected Capacitance
RAM	1GB
Storage	8GB
Camera/Microphone	Yes

DIMENSIONS	PDi-P16A-CWL-D	PDi-P19A-CWL-D
Weight Lbs. (Kg)	8 lbs (3.6 kg)	12 lbs (5.5 kg)
Unit Dimension (W/H/D) - Swivel	14.875" x 15.3125" x 1.875" 378 x 389 x 48 (mm)	20" x 17" x 2.5" 508 x 432 x 64 (mm)
Unit Dimension (W/H/D) - VESA	11.375" x 15.3125" x 1.875" 289 x 389 x 48 (mm)	20" x 13.75" x 2.5" 508 x 349 x 64 (mm)

Android is trademark of Google Inc.

medTAB is a trademark of PDi Communication Systems, Inc.

Some screen images are simulated.

Dimension and weights are approximate.

Design specification and features are subject to change without notice.