

	MODEL NUMBER: <h1 style="text-align: center;">PDI STM-AV</h1>	Document Number: PD196-193R2
	Installation of a PDI Standard AV Table Mount	Page 1 of 2

**Scope:**

To install a PDI-STM-AV swing arm mount.

**Notes:** Mounting fasteners are customer supplied. The standard fastener requirement is a 1/4" diameter grade 5 or higher fastener.

**Tool List:**

1. Safety glasses/goggles
2. Drill
3. Drill bit sized for the chosen mounting fasteners
4. 1" drill bit for coax hole
5. 1/8" hex key for pilfer proofing screw
6. Tools for installation of chosen mounting fasteners

**Safety Steps:**

1. Always wear safety glasses/goggles to prevent injury from debris.
2. Follow the installation/removal instructions for your existing products.

**Procedure:**

**Step 1:**

Locate and lay out the bolt pattern for the mounting fasteners and the coax/cable hole or cutout.

**Step 2:**

Follow the manufacturer's instructions for installation of the chosen mounting fasteners.

Drill the fastener holes to the manufacturer's specification.

Tighten the fasteners to securely hold the PDI-STM-AV to the mounting surface.

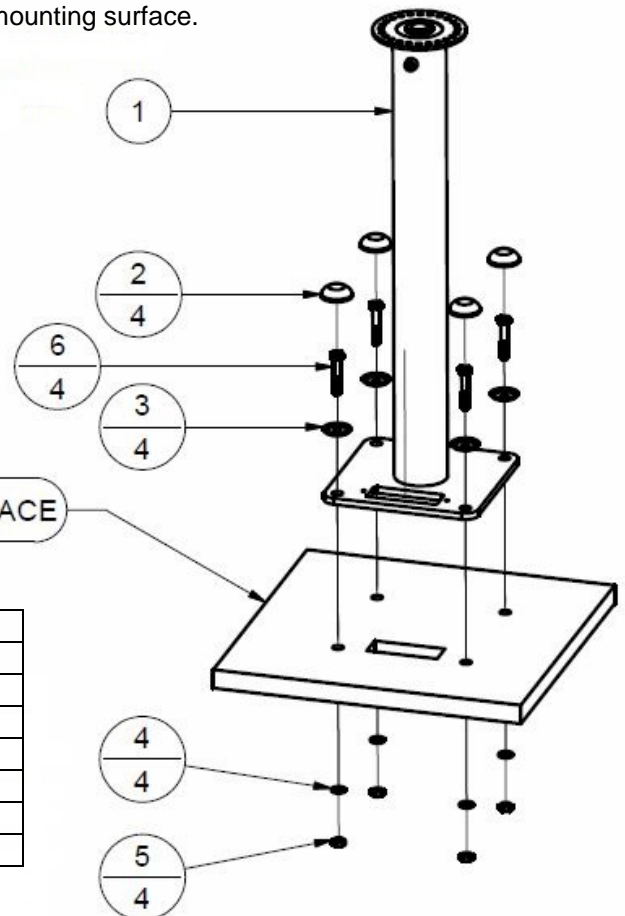
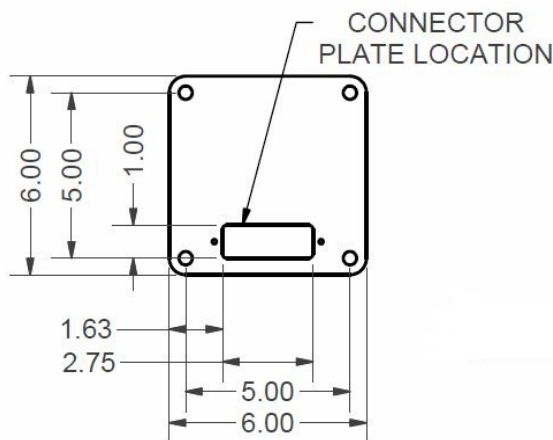

Parts List			
ITEM	QTY	PART NUMBER	DESCRIPTION
1	1	PDI-STM-AV	SINGLE TABLE MOUNT
2	4	PDI-271	CAPPLUG RH-20-JN (CREAM)
3	4	PDI-272	WASHER RHW-203
4	4	FLAT WASHER	CUSTOMER SUPPLIED
5	4	HEX NUT	CUSTOMER SUPPLIED
6	4	BOLT	CUSTOMER SUPPLIED

	MODEL NUMBER: <b>PDI STM-AV</b>	Document Number: PD196-193R2
	Installation of a PDI Standard AV Table Mount	Page 2 of 2

**Step 3:**

Use the 1/8" hex key to remove the pilfer proofing screw and spacer.

**Step 4:**

Install the arm (sold separately) into the table mount, taking care to properly align the base pin with the bushing to prevent damage to the bushing during installation.

**Step 5:**

Use the 1/8" hex key to reinstall the pilfer proofing screw and spacer.

Rotate the arm from side to side to verify that it moves smoothly and does not bind on the pilfer proofing screw.

Lift up on the arm to confirm that the arm cannot be removed while the pilfer proofing screw is installed.

