	MODEL NUMBER: PDI1295WRS	Document Number: PD196-194R4
	Installation of a PDI1295WRS and PDI1295WRS-AV Table Mounts	Page 1 of 4

SCOPE:

To install a PDI1295WRS or PDI1295WRS-AV swing arm mount.

NOTES: Mounting fasteners are customer supplied. The standard fastener requirement is a 1/4" diameter grade 5 or higher fastener.

TOOL LIST:

- 1) Safety glasses/goggles
- 2) Drill
- 3) Drill bit sized for the chosen mounting fasteners
- 4) 1" drill bit for coax hole
- 5) 5/32" hex key for pilfer proofing screw
- 6) Tools for installation of chosen mounting fasteners

SAFETY STEPS:

- 1) Always wear safety glasses/goggles to prevent injury from debris.
- 2) Follow the installation/removal instructions for your existing products.

PROCEDURE:

STEP 1:

Locate and layout the bolt pattern for the mounting fasteners and the coax/cable hole or cutout.

STEP 2:

Follow the manufacturer's instructions for installation of the chosen mounting fasteners. Drill the fastener holes to the manufacturer's specification. Tighten the fasteners to securely hold the PDI1295WRS to the mounting surface.

Installation instructions for PDI1295WRS

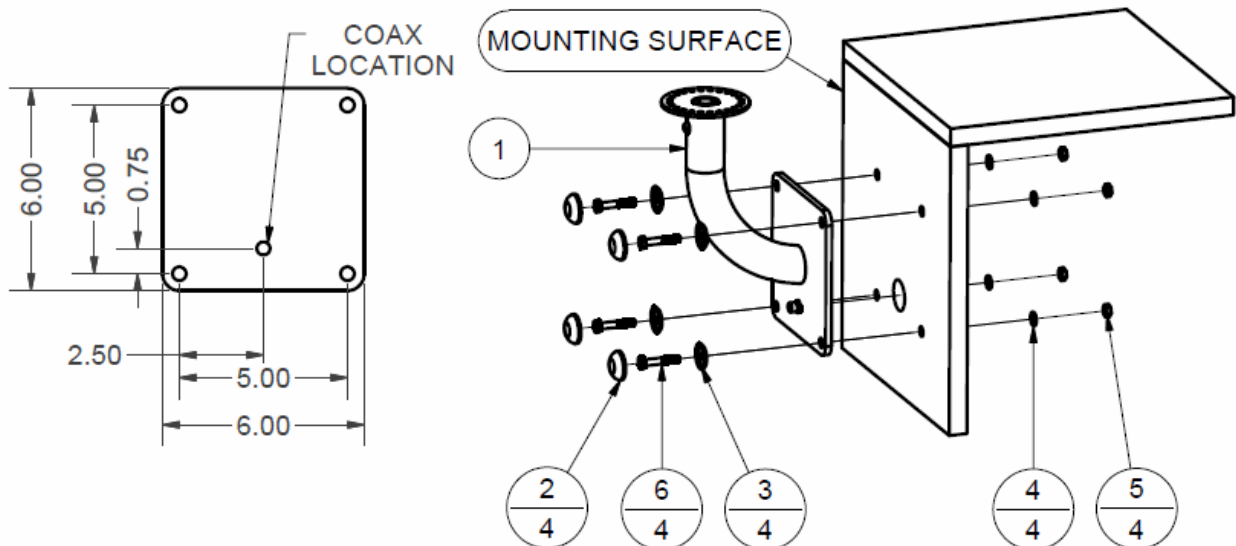

Parts List			
ITEM	QTY	PART NUMBER	DESCRIPTION
1	1	PDI1295WRS	RIGHT ANGLE TABLE
2	4	PDI-271B, C, OR G	CAPPLUG RH-20-JN
3	4	PDI-272	WASHER RHW-203
4	4	FLAT WASHER	CUSTOMER SUPPLIED
5	4	HEX NUT	CUSTOMER SUPPLIED
6	4	BOLT	CUSTOMER SUPPLIED

Installation instructions for PDI1295WRS-AV

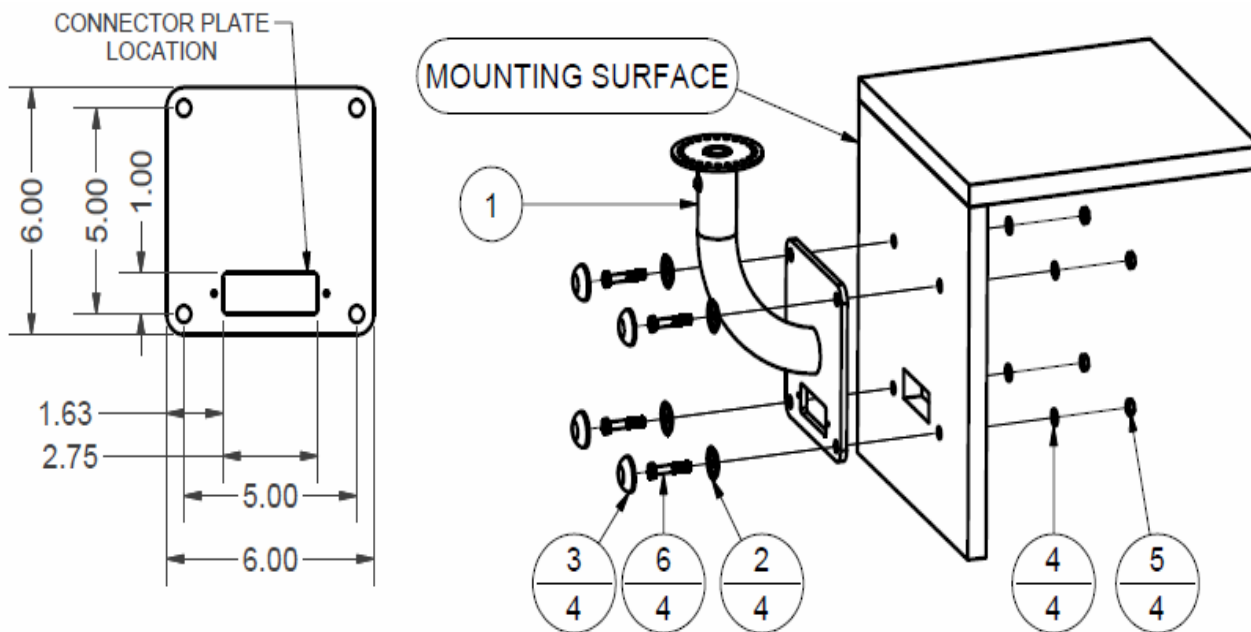

Parts List			
ITEM	QTY	PART NUMBER	DESCRIPTION
1	1	PDI1295WRS-AV	RIGHT ANGLE TABLE MOUNT
2	4	PDI-272	WASHER RHW-203
3	4	PDI-271B,C, OR G	CAPPLUG RH-20-JN
4	4	FLAT WASHER	CUSTOMER SUPPLIED
5	4	HEX NUT	CUSTOMER SUPPLIED
6	4	BOLT	CUSTOMER SUPPLIED

	MODEL NUMBER: PDI1295WRS	Document Number: PD196-194R4
	Installation of a PDI1295WRS and PDI1295WRS-AV Table Mounts	Page 3 of 4

STEP 3:

Use the 5/32" hex key to remove the pilfer proofing screw.

STEP 4:

Install the arm (sold separately) into the table mount, taking care to properly align the base pin with the bushing, to prevent damage to the bushing during installation.

STEP 5:

Use the 5/32" hex key to reinstall the pilfer proofing screw. Rotate the arm from side to side to verify that it moves smoothly and does not bind on the pilfer proofing screw. Lift up on the arm to confirm that the arm cannot be removed while the pilfer proofing screw is installed. (Figures A & B)

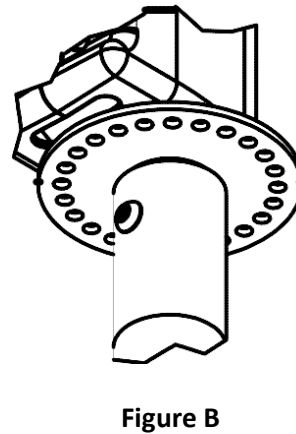
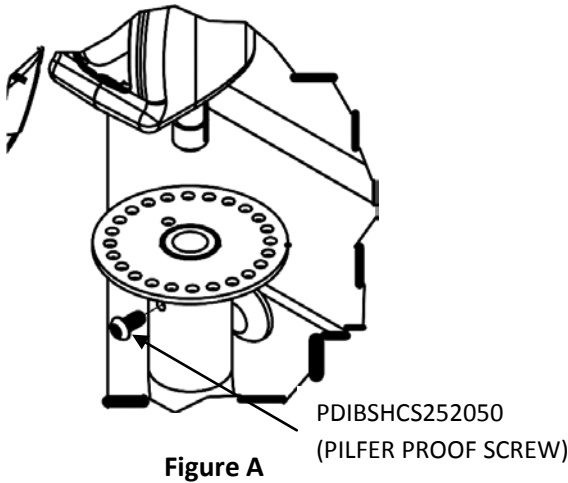

ROTATIONAL STOP DETAILS (Figure C & D)

Parts List		
QTY	PART NUMBER	DESCRIPTION
2	PDI-243	Rotational Stop Collar
2	PDIPPHMS1032100	10-32 x 1" Phillips Pan Head Machine Screw
2	PDINILN1032	10-32 Lock Nut -Nylon Insert

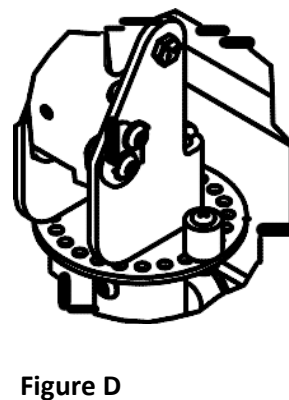
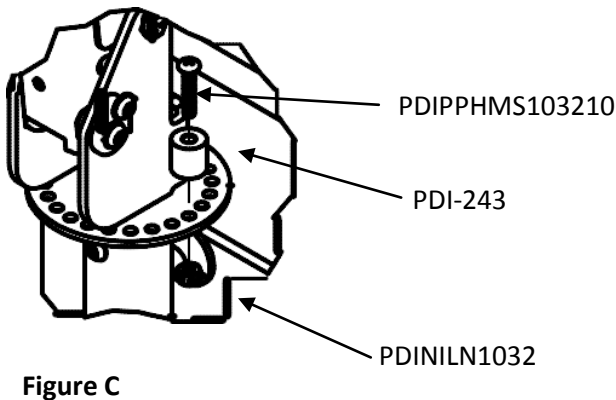

	MODEL NUMBER: PDI1295WRS	Document Number: PD196-194R4
	Installation of a PDI1295WRS and PDI1295WRS-AV Table Mounts	Page 4 of 4

Optional PDI-STM-BP Plate -Purchased separately. (It will replace the 4 Hex Nuts and Washers)
It works with both standard and AV models.

