

	MODEL NUMBER: <b>PDI-781</b>	Document Number: PD196-225R2
	Installation of PDI-781 wall bracket	Page 1 of 6

 <p>This symbol indicates that dangerous voltage constituting a risk of electric shock is present within this unit.</p>	 <table border="1"> <tr> <td style="background-color: black; color: white; text-align: center; padding: 5px;"><b>CAUTION</b></td> </tr> <tr> <td style="text-align: center; padding: 5px;">RISK OF ELECTRIC SHOCK, DO NOT OPEN!</td> </tr> </table>	<b>CAUTION</b>	RISK OF ELECTRIC SHOCK, DO NOT OPEN!	
<b>CAUTION</b>				
RISK OF ELECTRIC SHOCK, DO NOT OPEN!				
 <p>This symbol indicates that there are important operating and maintenance instructions in the literature accompanying this unit.</p>	<b>CAUTION: TO REDUCE THE RISK OF ELECTRIC SHOCK, DO NOT REMOVE COVER. NO USER SERVICEABLE PARTS INSIDE. REFER SERVICING TO QUALIFIED SERVICE PERSONNEL</b>			

**THIS INSTALLATION SHOULD BE MADE BY A QUALIFIED SERVICE PERSON AND SHOULD CONFORM TO ALL LOCAL CODES. READ AND FOLLOW THE SAFETY INSTRUCTIONS BEFORE ATTEMPTING THIS INSTALLATION.**

**NOTE to CATV system installer:** This reminder is provided to call the CATV system installer's attention to Article 820-40 of the NEC that provides guidelines for proper grounding and, in particular, specifies that the cable ground shall be connected to the grounding system of the building, as close to the point of cable entry as practical.

### **Minimum Installation Requirements:**

#### **Arm model notes:**

Contact PDI for complete list of compatible arm models that can be used with this wall bracket power supply.

#### **Wall construction notes:**

1. Wall studs are to be wood, with a 2x4 minimum size and be spaced 16" on centers.
2. Stud orientation shall be with the "4" inch dimension perpendicular to the surface plasterboard.
3. The surface plasterboard shall have a maximum thickness of 5/8".

#### **Notes for installation of PDI backer plates:**

1. Attaching fasteners will be 1/4" lag for the wood studs that provide a minimum of 2-1/2" engagement with the wood studs.

#### **Additional notes:**

At the time of this printing, these configurations have been evaluated and tested by Underwriters Laboratories. Other means of mounting may be potentially hazardous.

**Scope:**

To properly install the PDI-781 wall bracket to a support wall.

**Tool List:**

- 1) Safety glasses/goggles
- 2) 5/32 hex key or hex bit with driver
- 3) Wire stripper/crimper
- 4) Drill and appropriate bits for installation fasteners.

**Safety Steps:**

- 1) Always wear safety glasses/goggles to prevent injury from debris.
- 2) Follow the installation/removal instructions for your existing products.

**STEP 1: GUIDELINES**

- A. **LOCATION** – Make certain that the wall bracket mounting location allows for rear coax cable and ground wire entry through the wall to the back of the wall casting. Also position the wall bracket at a mounting height of 47+/- 2 inches. See Figure 1.
- B. **WALL STRENGTH** – The wall bracket mounting instructions cover the most desirable mounting method, back-to-back bracket mounting, plus some other recommended methods depending upon wall construction. **IN ALL CASES** the wall construction must be able to support a minimum loading of 350 PSI applied perpendicular to the mounting hole locations by compression or tension. Some wall construction may require internal bracing to accept the minimum loading required.
- C. **HARDWARE REQUIRMENTS** – Mounting fasteners for installation are NOT supplied with the wall bracket. Finishing Cap Covers and Cap Washers are supplied with the wall mount.
  1. All threaded rods, bolts or machine screws will be 1/4"-20UNC-2A thread or equivalent.
  2. The back-up plate is a 6-1/2" x 10", 11 gauge metal plate, with four 9/32" holes that coincide with the wall bracket. A pre-fabricated backing plate, PDI-218, is available directly from PDi.
  3. All threaded rods will be finished off with an acorn nut.
- D. **TOTAL WEIGHT** of the PDi 19" receiver and support arm system is 41 lbs approximately.

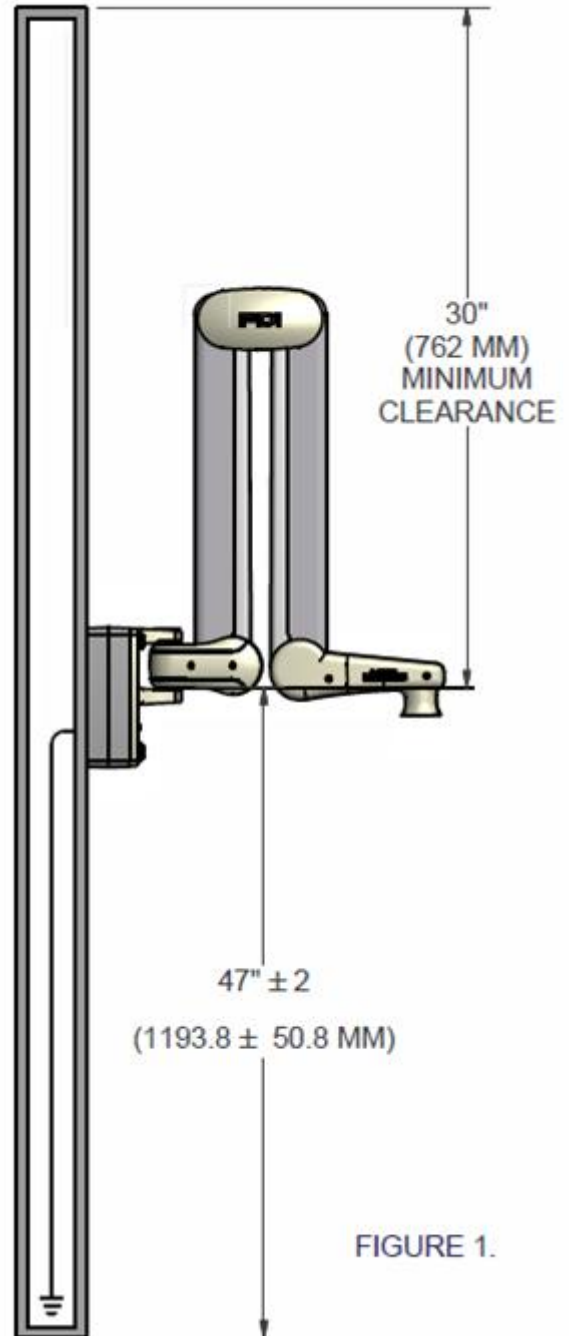
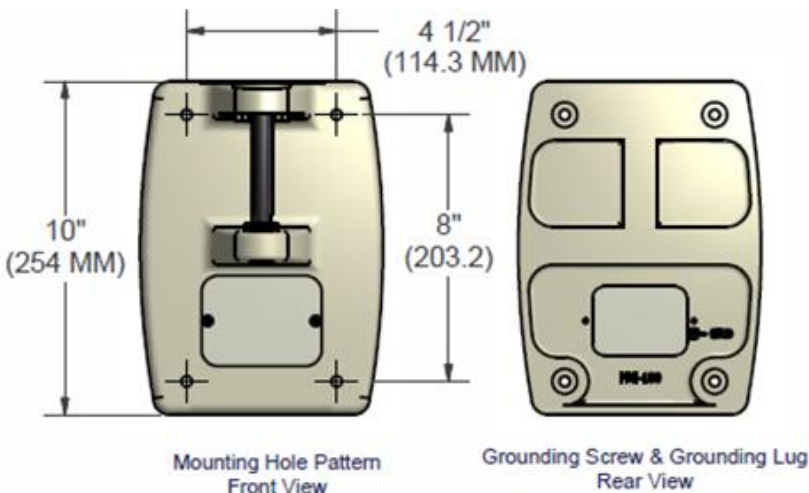
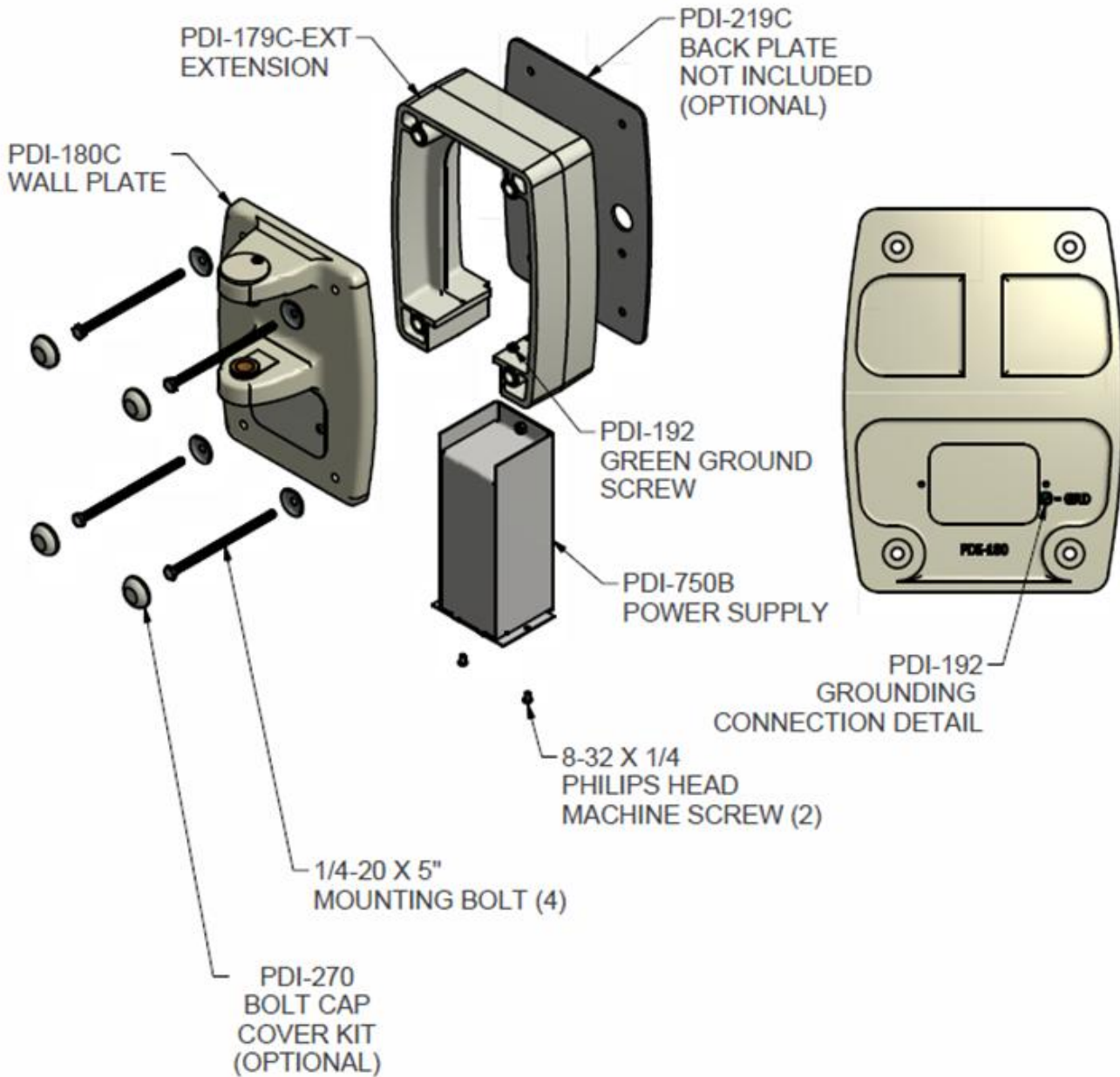

FIGURE 1.



The required mounting fasteners are to be supplied by the installer. These fasteners are to be 1/4" diameter and of Grade 5 or better material. Attachment to a PDi-254I or PDi-255E series backer plate requires 1/4-20 UNC threaded fasteners. PDi does supply the cosmetic cap cover kits with the wall brackets



NOTE: Grounding is required. Bond the green ground screw on the back of the PDI-781 wall bracket to the green ground screw on the PDI-179-ext extension. Connect these points to ground.

### BACK-TO-BACK MOUNTING

Refer to Figure 2.

1. Position the mount so the bolt pattern straddles an interior wall stud and allows for rear coax cable and ground wire entry through the wall to the back of the wall casting. Adjust the mounting height to a distance of 47+/- 2" from the floor to top of pivot hole as shown in FIGURE 1. It is also important that the mounting location be approximately 15" from the patient's bed. Please note also that the suspension arm requires a minimum clearance distance of 30" from ceiling to the top of the wall bracket. A check with the contractor/architect or Hospital Engineering Department regarding hidden objects behind the wall should be made before proceeding with this installation and final operation of the arm assembly.
2. Place a spirit level along the top surface of wall mount pivot hole and adjust for a true horizontal position. Mark the location of the mounting holes.
3. Drill the top holes completely through the wall with a 9/32" bit.
4. Drill the bottom mounting holes half-way through the wall and complete the holes from the opposite side.  
 NOTE: All holes must be drilled perpendicular to the wall so that they are spaced 4-1/2" on horizontal centers and 8" on vertical centers on the opposite side of the wall.
5. Route the coax through the front opening and secure the ground wire. Place a hex nut 5/16" on one end of each 1/4" threaded rod through the top mounting holes and through the top wall holes. Hold the wall bracket and rods in place and have an assistant fasten the mounting bracket in the opposite wall through the top holes using hex nuts. Tighten the nuts to a snug fit.
6. Cut the threaded rods 5/16" from the outside surface of the hex nut. Install and tighten cap nuts on rods.
7. Insert the additional threaded rods through the bottom mounting holes. Fasten, cut, and finish the rods as previously described in steps 5 and 6.

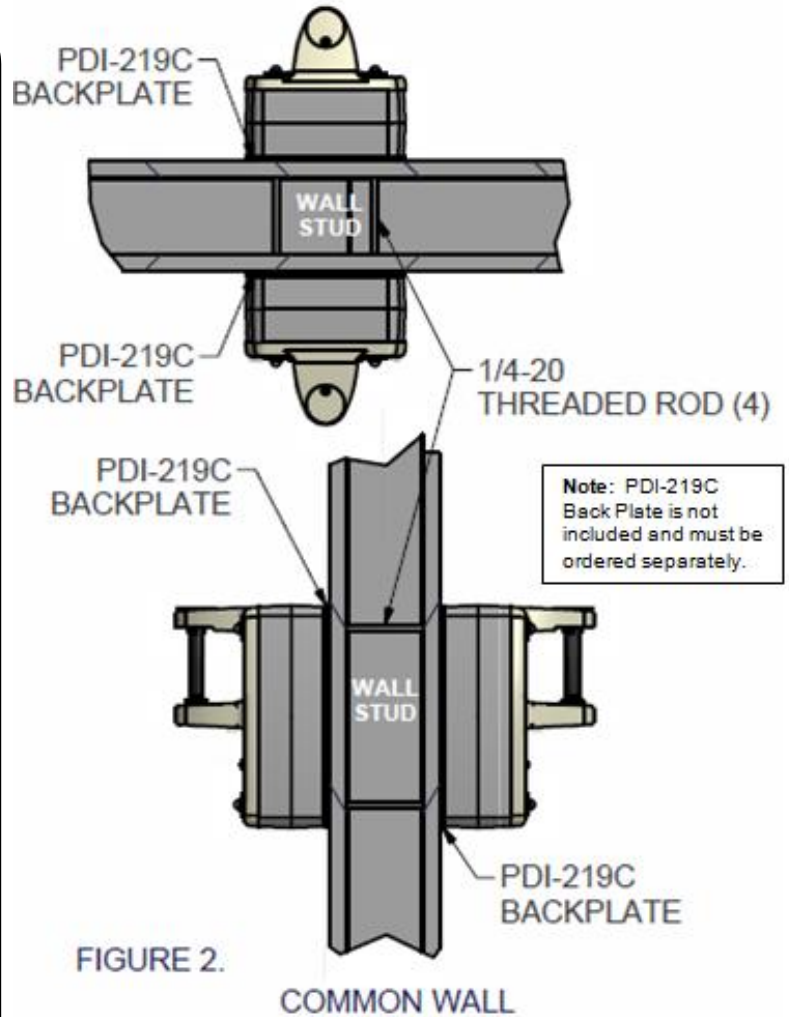

FIGURE 2.

COMMON WALL

Wiring Not Shown for Clarity

### BACK-UP PLATE MOUNTING

Refer to Figures 3 and 4.

1. Complete the first four steps 1 through 4 as previously described under "BACK-TO-BACK MOUNTING"
2. Route the coax through the front opening and secure the ground wire. Place a hex nut 5/16" from one end of threaded rod. Tighten cap nuts on rods so that the nut faces are even. Insert the threaded rods through the top and bottom mounting holes.
3. Hold the rods in place and have an assistant place and secure the back-up plate to the opposite wall using hex nuts. Cut the threaded rods 5/16" from the outside surface of the hex nuts.
4. Install and tighten cap nuts on rods.

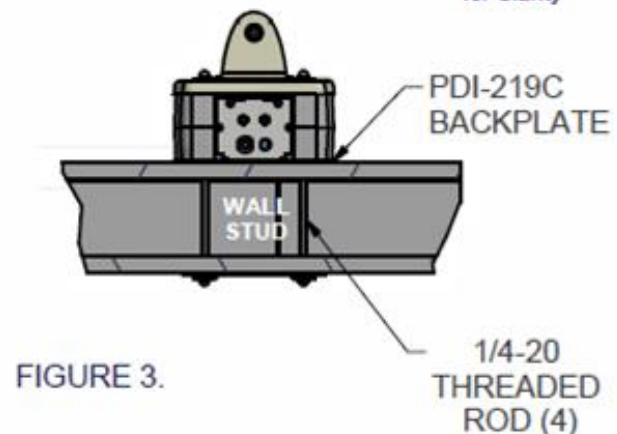

FIGURE 3.

1/4-20 THREADED ROD (4)



PDI-218 is an optional part to be purchased separately

**PDI-218  
 BACKUP PLATE**

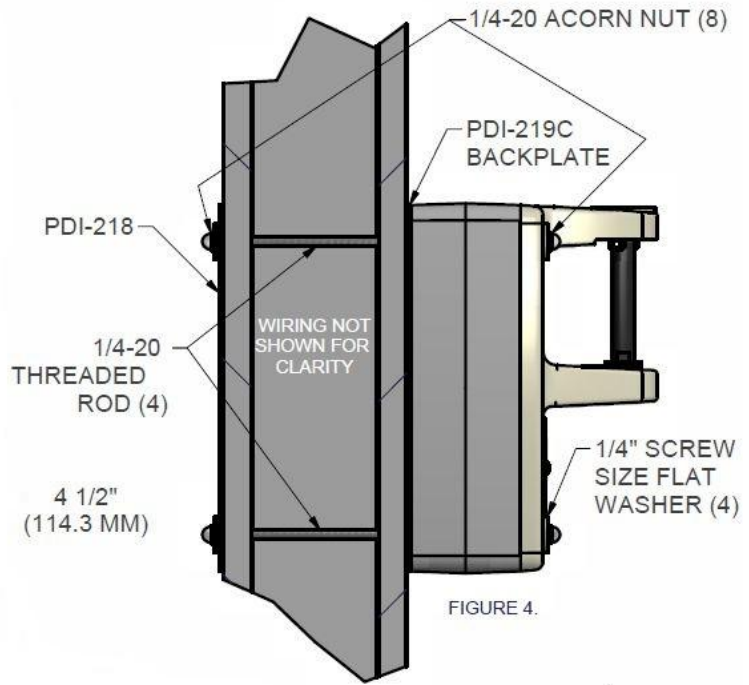
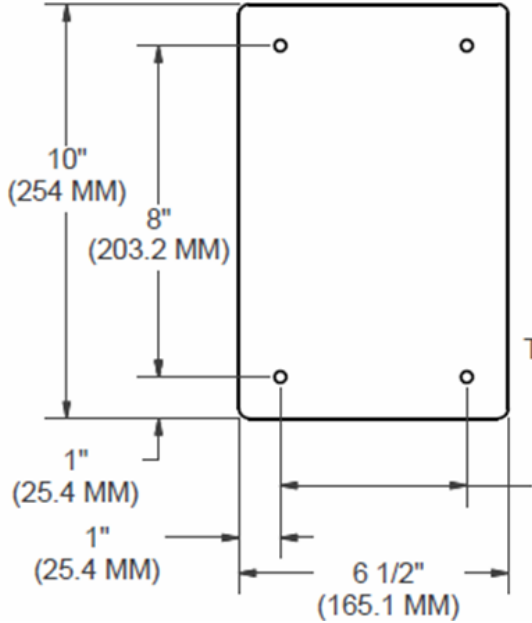

FIGURE 4.

**OTHER MOUNTING METHODS**

There are other methods to mount the wall bracket, but the PREFERRED mounting is a back-to-back system or back-up plate system as described. The mounting method used must meet the requirements as described in GENERAL GUIDELINES. The following mounting methods may be used if the previously listed precautions are adhered to.

1. SOLID CONSTRUCTION WALLS – Concrete, brick, and some types of cement block, cement expansion anchors can be used.



**Special tests should be performed on the wall before installation of the expansion anchors in the area of the bracket mounting location. Proof test the lead for the anchors to 1600 inch-pounds in tension.**

It is the responsibility of the architect and/or structural engineer, in general responsible charge of the project, to sign and submit the necessary calculations that show the adequacy of the wall where the TV arm and mounting bracket will be installed. Drill four, 3/8" diameter holes that correspond to the wall bracket mounting bolt pattern to a minimum depth of 2 1/2". Install four 3/8" x 2 1/2" HILTI KWIK BOLT cement anchors. Position the wall bracket over the exposed mounting holes. Thread bolt and washer through bracket and into hole. Tighten all bolts

2. FABRICATED BACKING PLATE – A fabricated plate is used that holds welded-on or pressed-in studs. The studs (1/4"-20UNC-2A) would be located on hole centers that coincide with the wall studs. The plate is then secured to the wall studs. A prefabricated plate PDI-254I or PDI-254I-24 is available from PDi. See FIGURE 5. An external plate is also available. Consult the backing plate instructions packed with each plate for installation details.

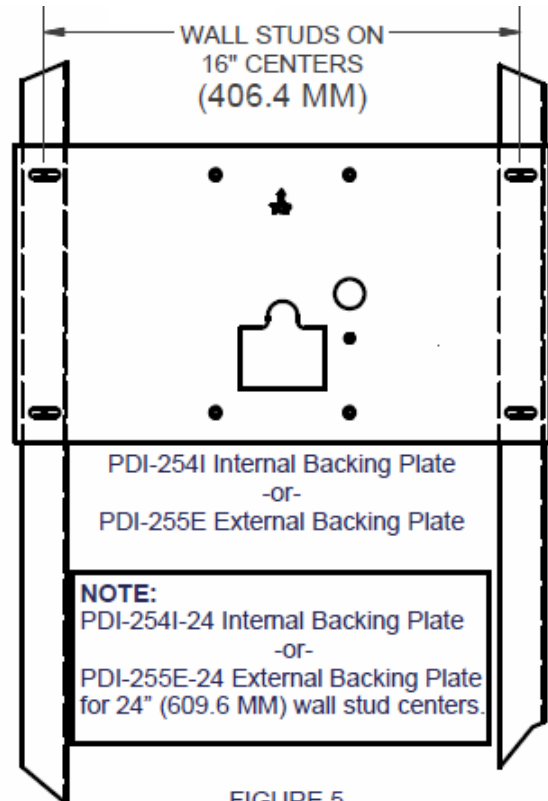

FIGURE 5.

**IMPORTANT SAFETY INSTRUCTIONS**

1. Read these instructions.
2. Keep these instructions.
3. Heed all warnings.
4. Follow all instructions.
5. Do not use this apparatus near water.
6. Clean only with dry cloth.
7. Do not block any ventilation openings. Install in accordance with the manufacturer's instructions.
8. Do not install near any heat source such as radiators, heat registers, stove, or other apparatus (including amplifiers) that produce heat.
9. Do not defeat the safety purpose of the polarized or grounding-type plug. A polarized plug has two blades with one wider than the other. A grounding type plug has two blades and a third grounding prong. The wide blade or the third prong are provided for your safety. If the provided plug does not fit into your outlet, consult an electrician for replacement of the obsolete outlet.
10. Protect the power cord from being walked on or pinched particularly at plugs, convenience receptacles, and the point where they exit from the apparatus.
11. Only use attachments/accessories specified by the manufacturer.
12. Use only with the cart, stand, tripod, bracket or table specified by the manufacturer, or sold with the apparatus. When a cart is used, use caution when moving the cart/apparatus combination to avoid injury from tip-over.
13. Unplug this apparatus during lightning storms or when unused for long period of time.
14. Refer all servicing to qualified service personnel. Servicing is required when the apparatus has been damaged in any way, such as power-supply cord or plug is damaged, liquid has been spilled or objects have fallen into the apparatus, the apparatus has been exposed to rain or moisture, does not operate normally, or has been dropped.



**OPERATION & SAFETY INSTRUCTIONS**

REFER TO FIGURE 6.

1. Attach coaxial cable from ARM to "F" fitting marked "RF/AC OUT". Wrench tighten.
2. Attach the Hospital Cable TV Cable (CATV) to the "F" fitting marked "RF IN". Wrench tighten.
3. Plug in line cord to 120 VAC outlet.
4. Verify normal TV operation.

**MAINTENANCE AND CLEANING/DISINFECTING**

1. Refer all maintenance to a qualified technician.
2. Hospital disinfectants may be used. Unplug the power supply from the wall outlet before cleaning. Dry only with a dry cloth.



**WARNING:** TO REDUCE RISK OF FIRE OR ELECTRIC SHOCK, DO NOT EXPOSE THIS POWER SUPPLY TO RAIN OR MOISTURE. THIS APPARATUS SHALL NOT BE EXPOSED TO DRIPPING OR SPLASHING AND THAT NO OBJECT FILLED WITH LIQUIDS, SUCH AS VASES, SHALL BE PLACED ON THE APPARATUS.



**CAUTION:** TO REDUCE THE RISK OF ELECTRIC SHOCK, DO NOT REMOVE COVER. NO USER SERVICEABLE PARTS INSIDE. REFER SERVICING TO QUALIFIED SERVICE PERSONNEL.



**CAUTION:** THIS POWER SUPPLY NOT FOR USE UNLESS INSTALLED INSIDE THE WALL CASTING.

**PDI-750B-SPECIFICATIONS**

Input	115VAC, 1A
Output	28VAC, 3A
Fuse	1A MDL
Insertion Loss (50MHz-850MHz)	<3dB
Return Loss (50MHz-850MHz)	>6dB

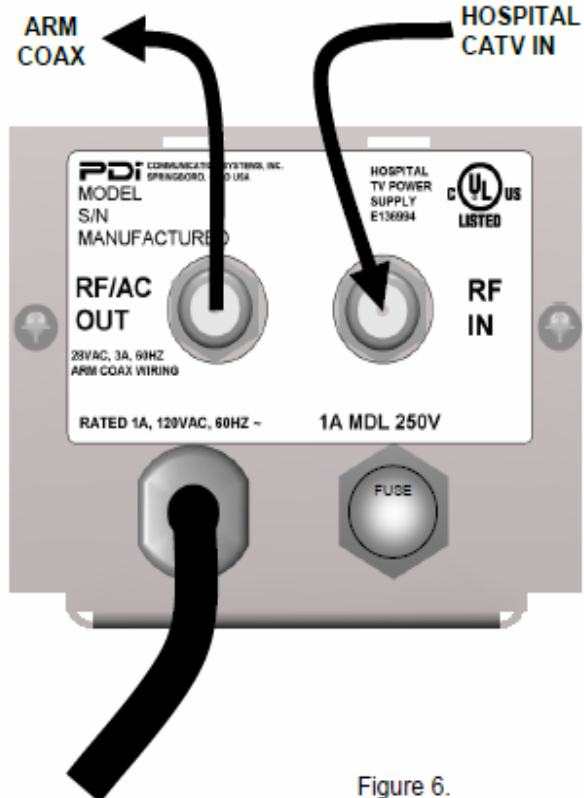

Figure 6.