

	MODEL NUMBER: PDI-STM-BP	Document Number: PD196-232R1
	Installation Instructions	Page 1 of 1

SCOPE:

To install a PDI-STM BACKER PLATE

NOTES: Mounting fasteners are customer supplied. The standard fastener requirement is a 1 / 4 - 20 diameter grade 5 or higher fastener. The backer plate has 1 / 4 – 20 threaded inserts.

TOOL LIST:

1. Safety glasses/goggles
2. Drill
3. Drill bit sized for the chosen mounting fasteners
4. 1" drill bit for coax hole
5. Tools for installation of chosen mounting fasteners

Safety Steps:

1. Always wear safety glasses/goggles to prevent injury from debris.
2. Follow the installation/removal instructions for your existing products.

PROCEDURE:

STEP 1:

Locate and layout the bolt pattern for the mounting fasteners and the coax/cable hole or cutout.

STEP 2:

Follow the manufacturer's instructions for installation of the chosen mounting fasteners.
Drill the fastener holes to the manufacturer's specification.
Tighten the fasteners to securely hold the PDI-STM to the mounting surface.

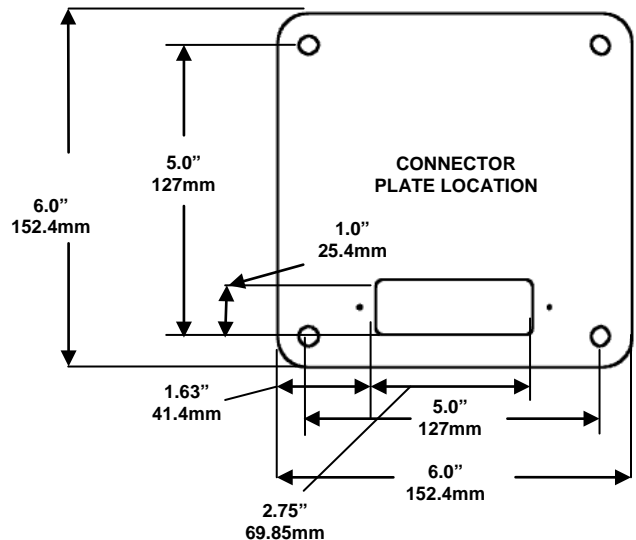
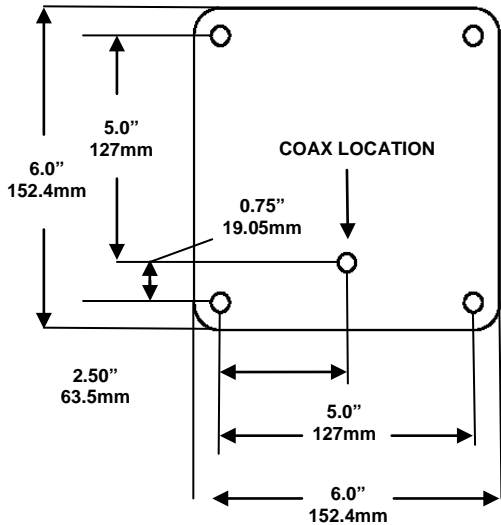
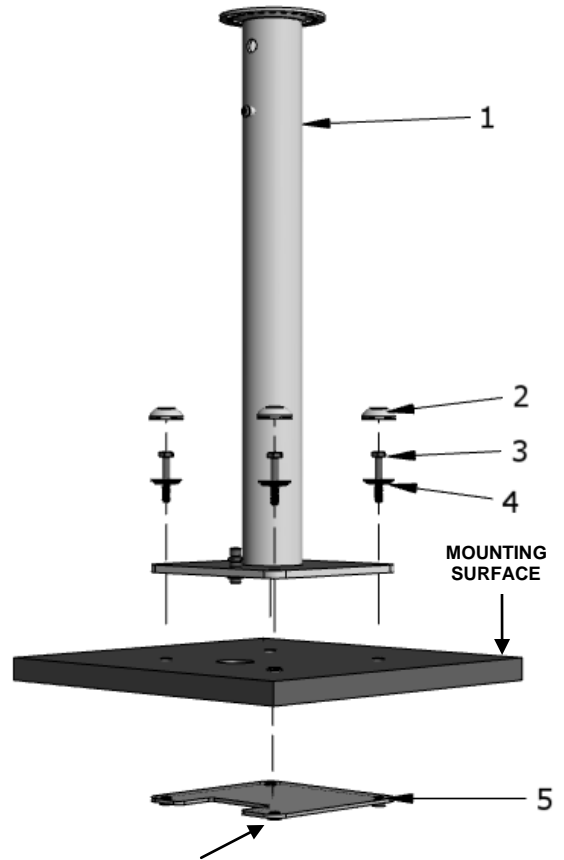

ITEM	Qty.	Part Number	Description
1	1	PDI-STM	Single Table Mount
2	4	PDI-271	Cap Plug RH-20-JN (Cream)
3	4	Bolt	Customer Supplied
4	4	Washer	Washer RHW-203
5	1	PDI-STM-BP	Backer Plate