	MODEL NUMBER: <b>PD181-677 100MM X 200MM</b>	Document Number: <b>PD196-260R1</b>
	<b>VESA Wall Mount Installation Instructions</b>	<b>Page 1 of 2</b>

**SCOPE:**

To install a PDi ELED television onto an existing PD168-103 mount using the PD181-677 adapter plate.

**NOTE:** This may also fit other manufacturer's 100mm x 100 mm VESA brackets. Mounts other than the PD168-103, may require using the M4 x 10 screws with the #10 flat washers for proper attachment.

**TOOL LIST:**

1. P1 or P2, Phillips screw driver
2. Safety glasses/goggles
3. Level

**SAFETY STEPS:**

1. Always wear safety glasses/goggles to prevent injury from debris.
2. Follow the installation/removal instructions for your existing products.

**PARTS LIST**

QTY	PART NUMBER	DESCRIPTION
1	PD181-677	100 x 200 ADAPTER PLATE
4	PDIITLW10	#10 Internal Tooth Lock Washer
4	PDIPPHMSM5X810	M5 x .8 x 10mm Long Phillips Head Screw
4	PDIPPHMSM6X116	M6 x 1 x 16mm Long Phillips Head Screw
4	PDIPPHMSM4X76	M4 x .7 x 6mm Long Phillips Head Screw
4	PDIPPHMSM4X710	M4 x .7 x 10mm Long Phillips Head Screw
4	PDIFW10	#10 Flat Washer

The PDIFW10 AND PDIPPHMSM4710 washers and screws are included to be used if this adapter plate is being paired with a thicker wall mount.

**PROCEDURE:**

1. Secure wall bracket PD181-596 (not included) to PD181-677 adapter plate using (4) PDIPPHMSM4X76 screws and (4) PDIITLW10 internal tooth lock washers as shown. (Fig. 1)

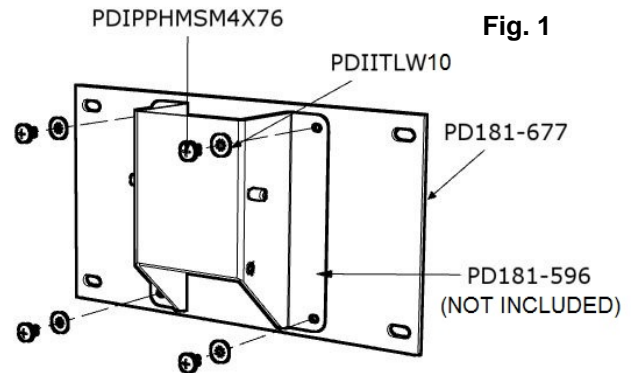

2. Secure the PD181-677 adapter plate to TV using (4) PDIPPHMSM5X810 screws for 29" TV or (4) PDIPPHMSM6X116 screws for 32" TV (Fig. 2)

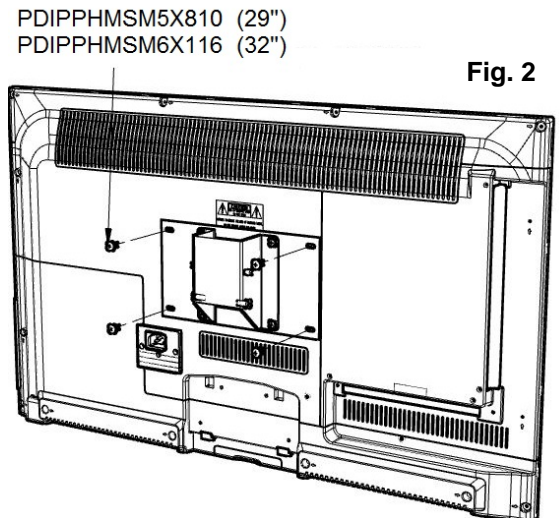

- Mate the PD181-596 mounting bracket on TV to PD181-697 bracket on wall (both parts from PD168-103 mount) using (2) PDIPPBHSCS103250 pilfer proof button head socket screws. Make sure the pivot bolts are retained in the "L" shaped slot (Fig. 3)

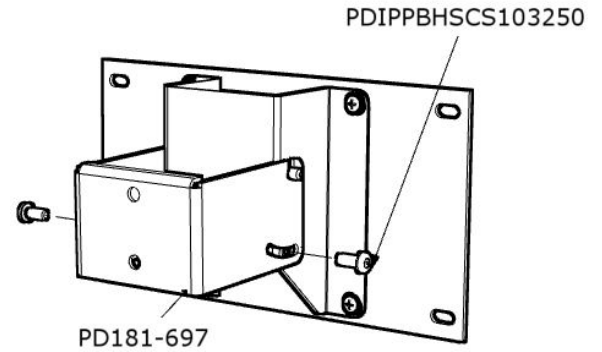
**Fig. 3**

- The TV's tilt can be adjusted by loosening both Pilfer Screws, adjusting tilting, and then tightening the (2) PDIPPBHSCS103250 pilfer proof head socket screws.

