

This mount is designed to fit a tablet:
9.4" x 6.6" x .28"
240mm x 169.5mm x 7.5mm

Power Cable Installation



Caution: Install the iPad® Air / iPad® Air 2 into the enclosure before attaching the enclosure to the support.

Tools (Included)

- T8, Pilfer tool bit

Tools (Not Included)

- Phillips screwdriver (P0 or P1)
- PD219-020 5/32" Tamper resistant tool bit for adjustment in field.

Installing Power Cord

1. Route the power cord through hole in bracket and back into inside of channel as pictured.
 Note: USB connection will be made in the nose.
2. Using Phillips screwdriver, secure **PD133-917** with **(4) PDIPPHMS44019** screws. Be sure power cord is under cover and can move freely.

Tablet Assembly

3. Place tablet screen protector **PD120-011** over the tablet. Align holes to their respective holes on the tablet.
4. Place the tablet into the enclosure base **PD133-947** so the buttons, earphone jack, speaker, and power port align with the access holes.
5. Place the enclosure front cover **PD133-948** onto the assembly and align the camera and home button openings.
6. Secure with **(4) PDIPPHMS44019** screws and **(4) PD220-119** washers as shown and hand tighten with Phillips screwdriver..

* Make sure the aligning bosses of the front cover are properly seated into the assembly holes of the enclosure base before tightening these screws.

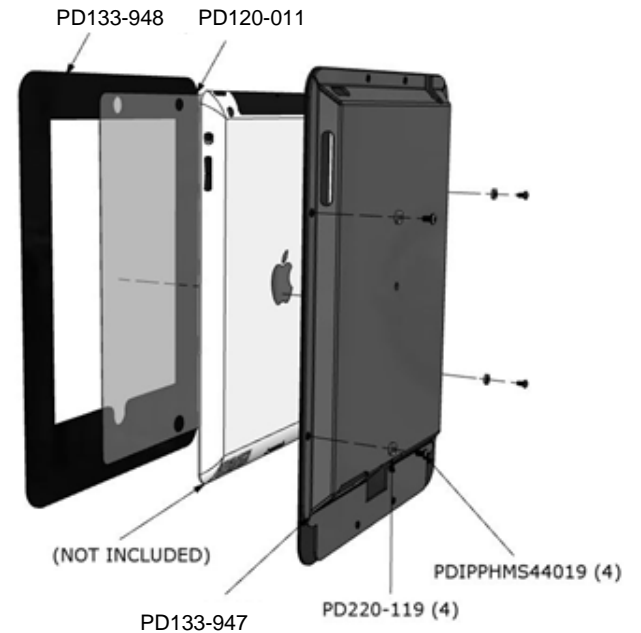
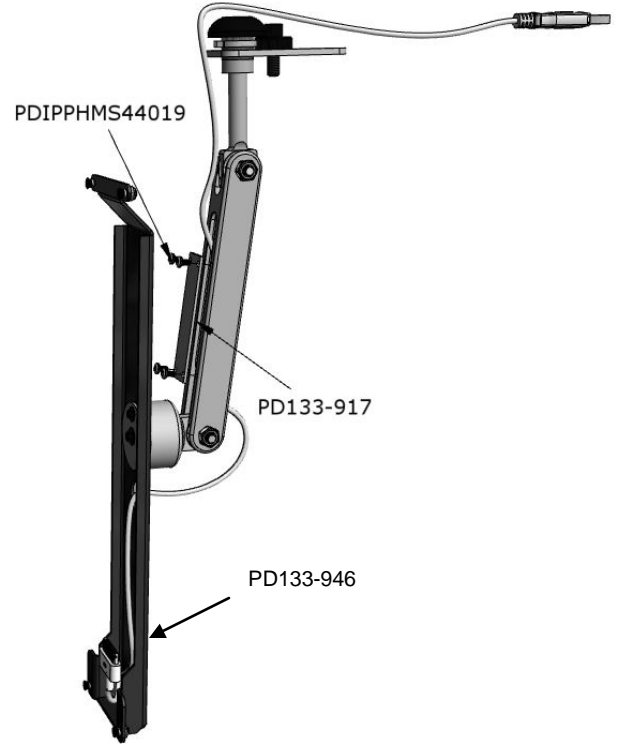

Connecting Tablet and Attaching Swivel Bracket to Tablet Assembly

7. Securely plug in the tablet power cord as shown.
8. Install (4) **PDIPPTBHSCS44025** security screws and (4) **PD220-119** washers to top and bottom of tablet assembly using T8 tool.
9. Check all assembly screws to verify they are tight.



Mounting Tablet to Arm

10. Insert the swivel assembly into the nose slot of the support arm and align the mounting hole of the assembly with the threaded mounting hole in the nose.
11. Install the supplied 1/4-20 socket head mounting bolt (**PDISHCS252075**) using a 3/16" hex key and securely tighten.
12. Route the iPad Air power cord into the nose and make the cable connection to the support arm cable.
13. Close the nose cover.
14. Verify the installed mount moves freely through all ranges of motion, without binding.
15. Install plastic arm covers.

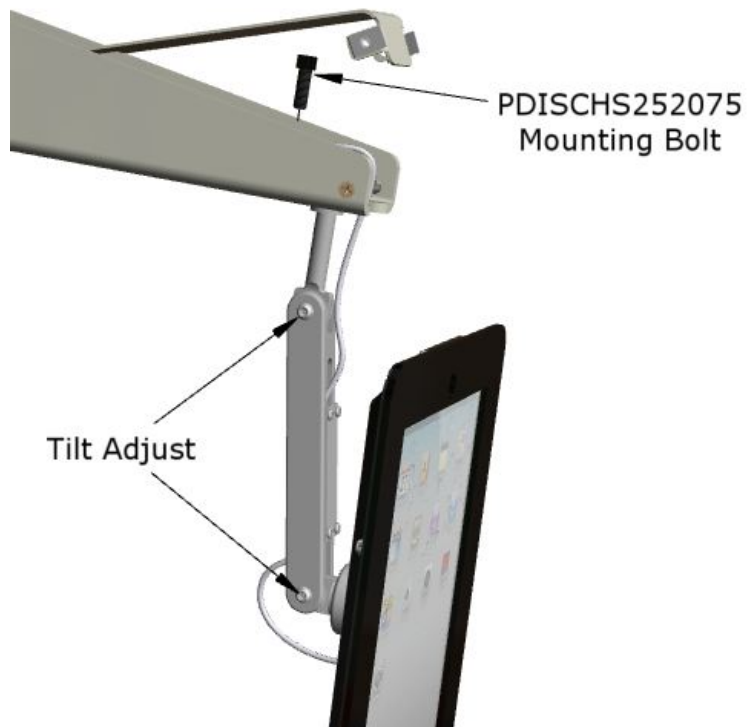

*Trademarks are the property of their respective owners.