

PD251-047

Universal Android Module Kit
(Shown with optional Wi-Fi)

Document Number PD196-370R1

Copyright, Trademarks, and Disclaimer

Copyright, Trademarks

© 2016 PDi Communication Systems, Inc. All rights reserved. PDi-TAB[®] is a registered trademark of PDi Communication Systems, Inc. Product logos, brands and other trademarks displayed within PDi's products are the property of their respective trademark holders, who are not affiliated with, endorsing, or sponsoring PDi Communication Systems, Inc. or our products.

Disclaimer

The author and publisher have used their best efforts in preparing this manual. PDi Communication Systems, Inc. makes no representation or warranties with respect to the accuracy or completeness of the contents of this manual and specifically disclaims any implied warranties or merchantability or fitness for any particular purpose and shall in no event be liable for any loss of profit or any other damages. The information contained herein is believed accurate, but is not warranted, and is subject to change without notice or obligation.

SAFETY INSTRUCTIONS

CAUTION: THIS INSTALLATION SHOULD BE MADE BY A QUALIFIED SERVICE PERSON AND SHOULD CONFORM TO ALL LOCAL CODES. READ AND FOLLOW THE SAFETY INSTRUCTIONS BEFORE ATTEMPTING THIS INSTALLATION.

1. Read Instructions – All the safety and operating instructions should be read before the product is operated.
2. Keep these Instructions – The safety and operating instructions should be retained for future reference.
3. Heed all Warnings – All warnings on the product and in the operating instructions should be adhered to.
4. Follow all Instructions – All warnings on the product and in the operating instructions should be followed.
5. Water and Moisture – Do not expose this product to rain or moisture. Do not use this product near water – for example, near a bath tub, wash bowl, kitchen sink, or laundry tub; in a wet basement; or near a swimming pool; and the like.
6. Cleaning – Unplug this product from the wall outlet before cleaning. Do not use liquid cleaners or aerosol cleaners. Clean only with a dry cloth.
7. Ventilation – Slots and openings in the cabinet are provided for ventilation to ensure reliable operation of the product and to protect it from overheating. These openings must not be blocked or covered. The openings should never be blocked by placing the product on a bed, sofa, rug, or other similar surface. This product should not be placed in a built-in installation such as a bookcase or rack unless proper ventilation is provided or the manufacturer's instructions have been adhered to.
8. Heat – The product should be situated away from heat sources such as radiators, heat registers, stoves, or other products (including amplifiers) that produce heat.
9. Power-Cord Protection – Protect the power cord from being walked on or pinched, particularly at plugs, convenience receptacles, and the point where they exit from the product.
10. Attachments – Only use attachments/accessories specified by the manufacturer.
11. Servicing – Refer all servicing to qualified service personnel. Servicing is required when the apparatus has been damaged in any way, such as power cord or plug is damaged, liquid has been spilled or objects have fallen into the apparatus, the apparatus has been exposed to rain or moisture, does not operate normally, or has been dropped.
12. Oxygen Environment – Do not use in an oxygen tent or oxygen chamber. Such use may cause a fire hazard.
13. Power Sources – This product should be operated only from the type of power source indicated on the marking label. If you are not sure of the type of power supply to your home, consult your product dealer or local power company. For products intended to operate from battery power, or other sources, refer to the operating instructions.
14. To ensure proper operation and to meet safety and electromagnetic interference (EMI) requirements, you must connect the module to earth ground before you connect power. You must use the protective earthing terminal on the chassis to connect the module to earth ground. A qualified electrician must install the ground wire to the module and to a proper earth ground.

 <p>This symbol indicates that dangerous voltage constituting a risk of electric shock is present within this unit.</p>	 <div style="background-color: black; color: white; padding: 2px; text-align: center;">CAUTION</div> <p style="text-align: center;">RISK OF ELECTRIC SHOCK, DO NOT OPEN!</p>	
 <p>This symbol indicates that there are important operating and maintenance instructions in the literature accompanying this unit.</p>	<p>CAUTION: TO REDUCE THE RISK OF ELECTRIC SHOCK, DO NOT REMOVE COVER. NO USER SERVICEABLE PARTS INSIDE. REFER SERVICING TO QUALIFIED SERVICE PERSONNEL</p>	

Technical Specifications*

CORE FEATURES		
OS		Android 4.3 (Jelly Bean)
CPU		Arm A9 Quad Core 1.0GHz
GPU		2D & 3D accelerator
Ethernet		100/1000 Mbps
RAM		1GB
Storage		8GB total. 3GB available for patient apps including up to 1GB for media files
USB Web Camera Compatible		YES
WIFI (OPTIONAL)		
WiFi Compatibility		802.11b/g/n/ac
WiFi Radio		Intel Dual Band Wireless-AC 3160
POWER		
Power		Consumption Max 13W
Voltage		12V DC

*Technical specifications could change without prior notice

Connections

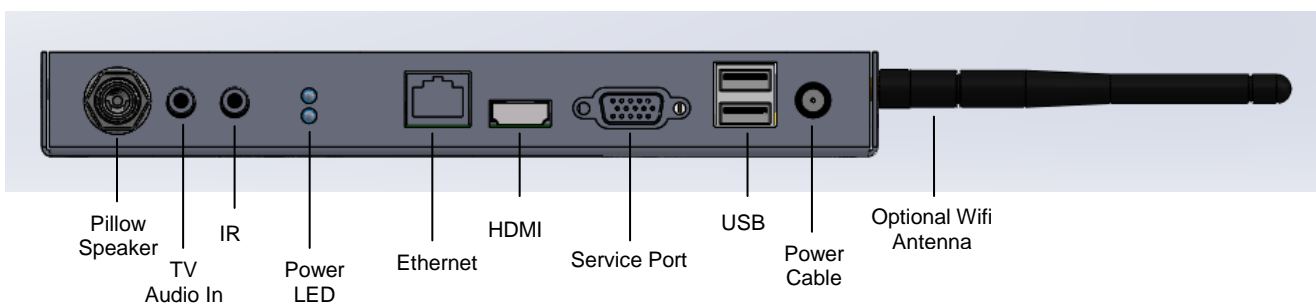

Installation

PDi offers a wide range of wall, floor and ceiling mounting options. Installation of the Universal Android Module is shown with compatible PDi brackets. Use of any other bracket may require modification of installation. The Universal Android Module contains a 100mm and 200mm VESA pattern. Contact PDi for compatible PDi bracket information.

Tool List:

1. Safety glasses/goggles
2. P1 or P2 Phillips screwdriver

Safety Steps:

1. Always wear safety glasses/goggles to prevent injury from debris.
2. Follow the installation/removal instructions for your existing products.

Parts List

PART NUMBER	QTY	DESCRIPTION
PD251-047	1	UNIVERSAL ANDROID MODULE
PD106-888	1	HDMI MALE TO MALE 36" CABLE
PD106-886	1	IR XMIT/RCV CABLE
PD196-370	1	QUICK START GUIDE, UNIVERSAL ANDROID MODULE
PDIPPHMSM4X710	2	M4 PHILLIPS SCREW
PDIPPHMSM6X110	2	M6 PHILLIPS SCREW

Mounting

The Universal Android Module is designed to mount to the rear of most televisions with standard 100mm or 200mm VESA mount points. These instructions assume the PDi PD168-033 mounting kit or PD168-103 mounting kit (Purchased Separately) are being used.

Step 1 (200mm Mounting Holes):

Loosen (2) M6 screws on the PD168-033 kit plate and insert Universal Android Module between plate and TV. Tighten (2) M6 screws.

Step 1 (100mm Mounting Holes):

Loosen (2) M4 screws on the PD168-103 kit plate and place Universal Android Module on top of mounting plate. Tighten (2) M4 screws.

Step 2:

Remount the television per manufacturer's installation instructions for your product.

Mounting using 200mm holes

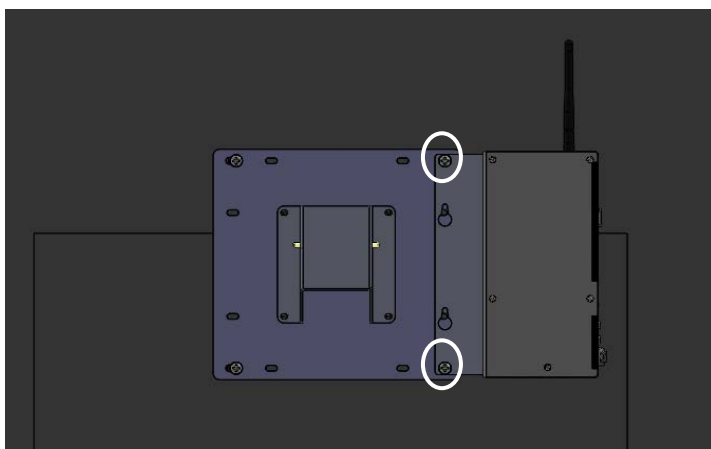

Mounting using 100mm holes

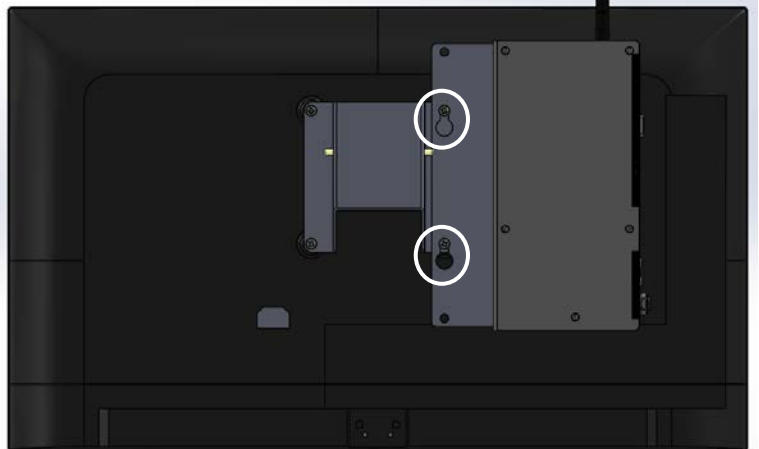

Ground Connection

1. Obtain 14AWG stranded copper wire with 90°C green/yellow-stripe insulation, or as required by local electrical code.
2. Terminate the wire at one end with Panduit P14-4R or equivalent listed terminal for a #4 screw.
3. Terminate the other end of the wire as appropriate for your installation.
4. Connect one end of the grounding cable to a permanent earth ground, such as the AC outlet wall plate.
5. Place the ring terminal attached to the grounding cable over the supplied #4 screw.
6. Secure the grounding screw to the protective earthing location on the module.

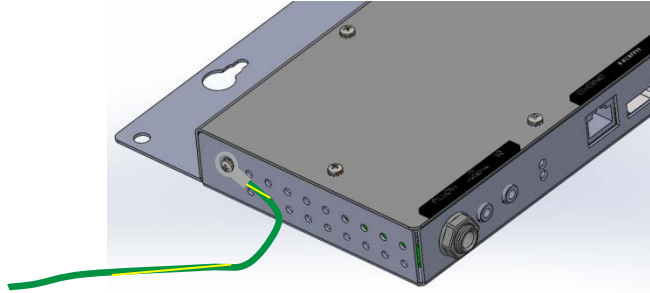

IR Cable Connection

1. Attach the supplied Infrared (IR) transmitter/receiver cable to the Universal Android Module's "IR" connector.
2. The small end of the cable is the IR transmitter. It must be affixed to the TV on top of the TV's IR window so that the TV can see the signals sent from this transmitter.
3. It is recommended to use black electrical tape to cover the IR transmitter so no other signals will pass into the TV.
4. The device in the middle of the cable is the IR receiver. Mount it on the side of the TV or a nearby surface so that it can see the IR beam from the TV's remote control. If the TV's remote will not be used in this application, then skip this step. Note the Universal Module is not compatible with all TV's remote codes. Please contact PDI Communication Systems for compatibility information.

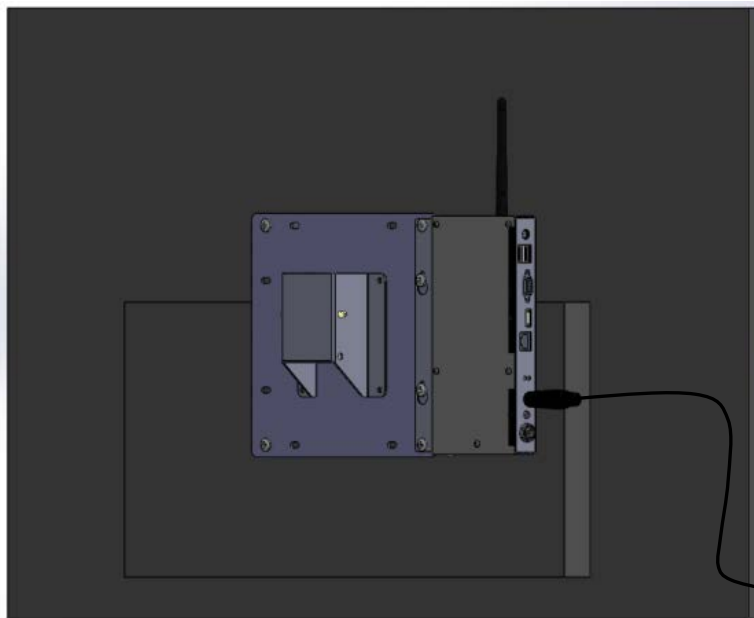

Pillow Speaker Connection

The Universal Android Module is compatible with most pillow speakers available today. The pillow speaker may connect directly to the module, or it may route through a nurse call system. In either case, the *data*, *speaker*, and *common* signals must terminate into a 1/4" phone plug. Verify the proper termination then attach the phone plug to the module as shown.

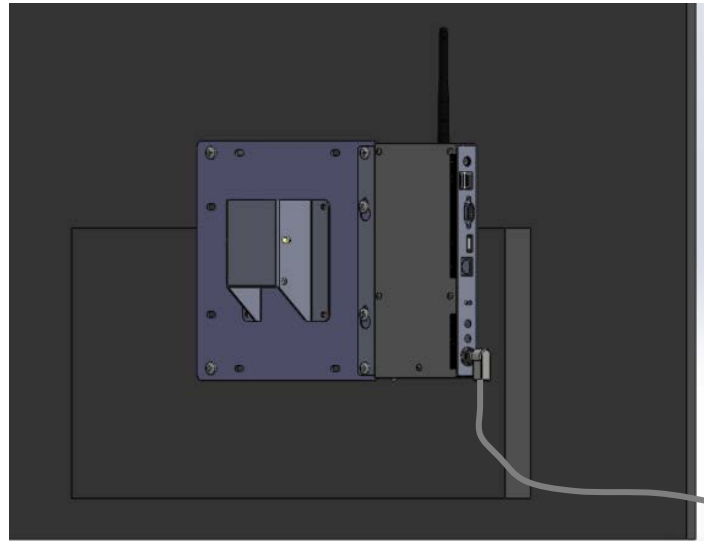

If needed, the following jumper cables may be ordered from PDI Communication Systems.

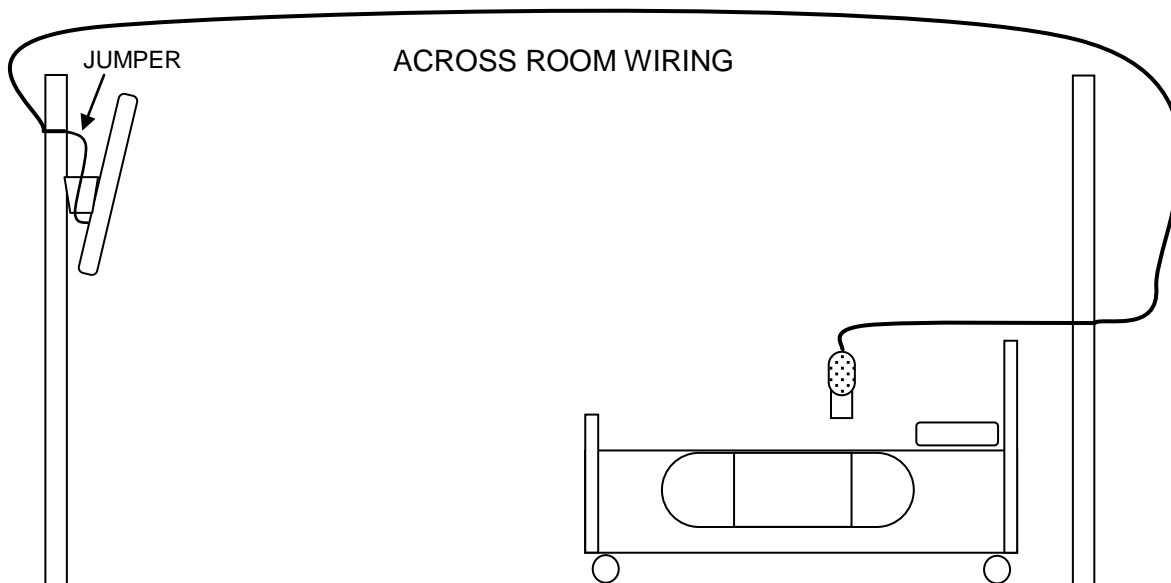
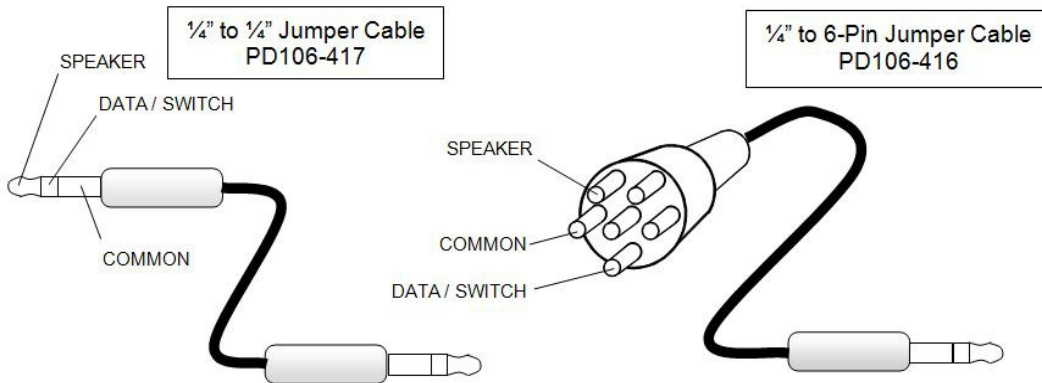

TV Audio Connection

If it is necessary to route TV audio through the pillow speaker, then connect an appropriate audio patch cable (purchased separately) between the Universal Android Module's "TV AUDIO IN" connector and the TV's audio output.

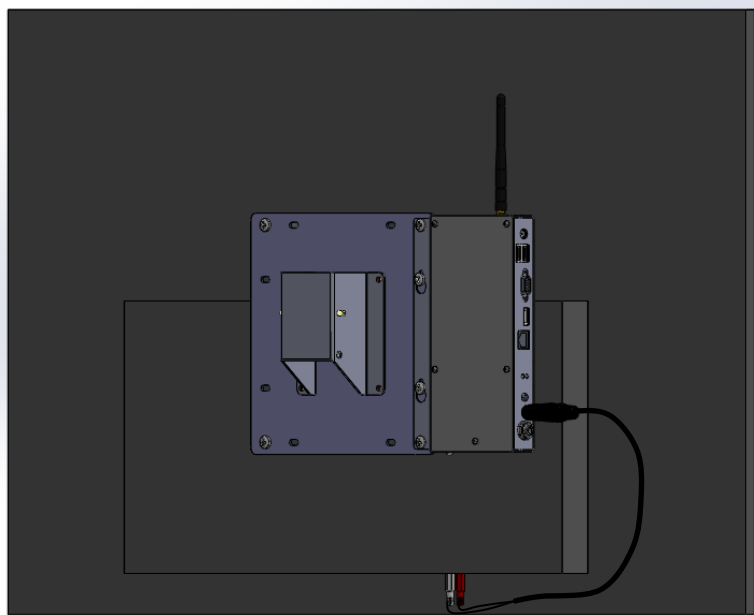

Power Adapter and HDMI Connections

Attach the supplied HDMI cable to the Universal Android Module. Attach the other end to any free HDMI port on the TV.

Finally attach the PD239-237 power adapter to the Universal Android Module, then to AC power.

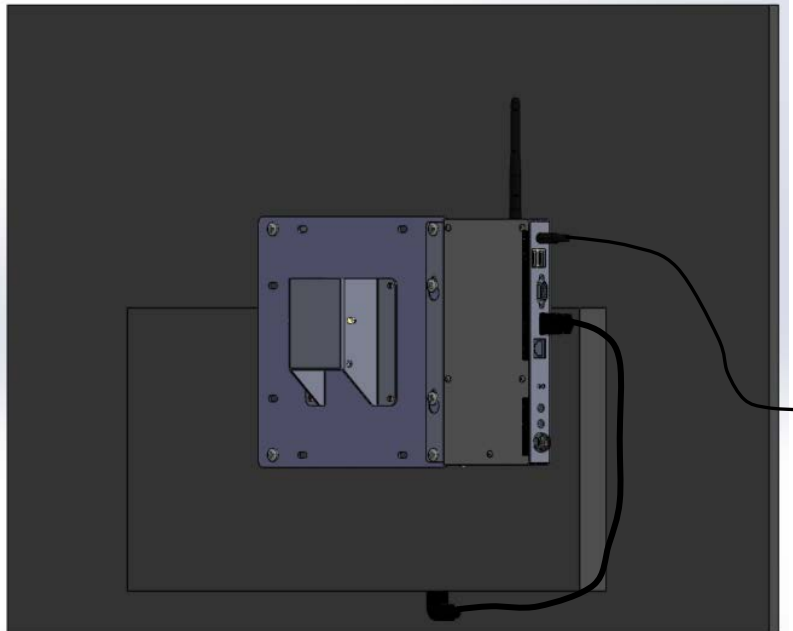

Screen Format Configuration

Set the TV to display the Universal Android Module by choosing the corresponding HDMI input. The default screen format may be zoomed so that the edges are cropped. Repeatedly press the ARC or ASPECT button on the remote supplied with the TV until the on-screen display shows “Full Screen” or “Just Scan”.

Keyboard

You may have the PD161-004 PDi wireless keyboard (purchased separately) or other compatible keyboard for use with this module. If you are using the PDi wireless keyboard, it will function as any 83 key QWERTY keyboard with several “Hot” keys.

Hot Keys	Function
Fn/Pair	Pair Keyboard with Module
Esc	Back one screen
Fn/Home	Home screen

Pull Down Panels

By pressing the mouse and scrolling down from the top, you can reveal two different information panels.

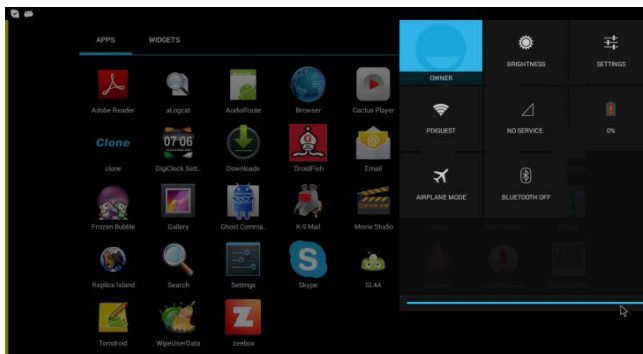

Quick settings panel. This is on the right side of a screen and gives you direct entry into different areas of the settings app, depending on which icon you choose.

Notification panel. This is on the left side of a screen and provides you with system notifications. Selecting one of these notifications can take you directly to the app responsible for it.

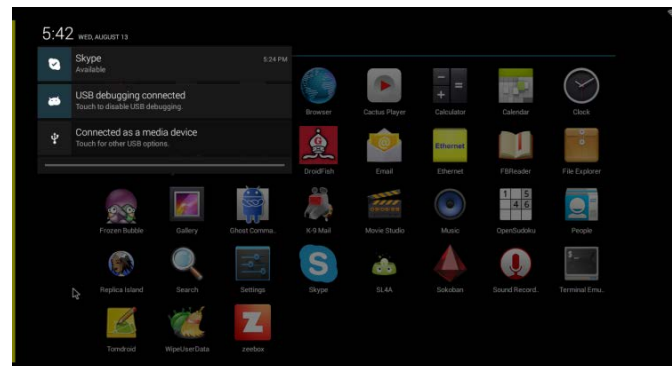

Settings

From the android home screen select “ALL APPS”, then select “Settings”. You will enter the Setting screen where you can adjust network, sound, and account settings.

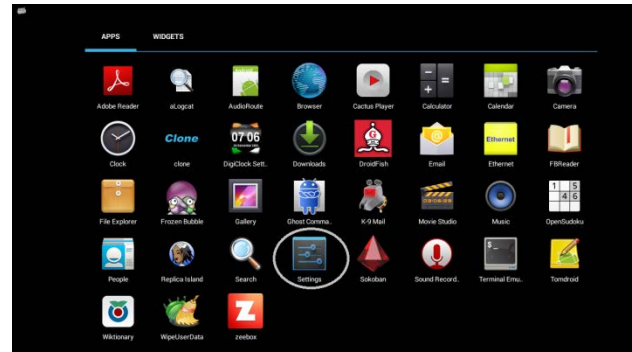

Connect To Wi-Fi Networks (Optional)

If the Universal Android Module has the Wi-Fi option, follow the instructions to connect to a wi-fi network.

1. Open Settings.
2. Slide the Wi-Fi switch to the *On* position.
(If not already set to “on”)
3. The module scans for available Wi-Fi networks and displays the names of those it finds. Secured networks are indicated with a  *locked* icon.
4. If the module finds a network that you connected to previously, it connects to it.
5. Select a network name to see more details or connect to it, and type a security code if necessary.

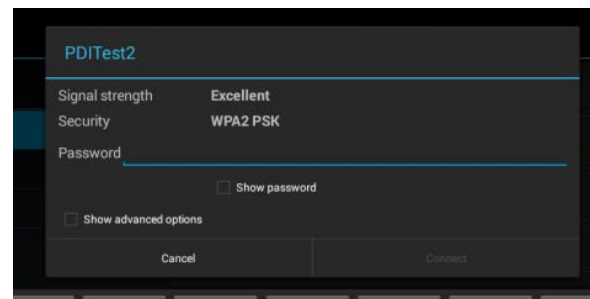
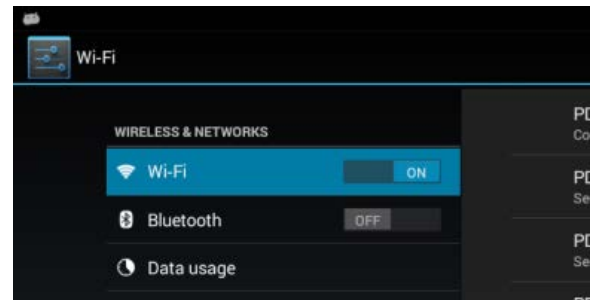

Troubleshooting

Hard Reset Information

If the TV becomes unresponsive, remove power from the Universal Android Module and reconnect power.

Additional Information

Additional information is available in the user manual. You can access this information online at <http://pdidisplay.com>. For instructional installation video go to <http://youtube.com/pdiuniversity>.

Limited Warranty

PDi Communication Systems Inc., ("PDi") warrants, to the original purchaser only, that the product will be free from defects in materials and workmanship, under normal use, for 2 years from the date of original purchase. This warranty does not cover any other equipment that may have been included with PDi's shipment of this product.

After receipt of written notice of a defect or malfunction occurring during the warranty period, PDi will repair or replace goods returned to its Springboro, Ohio location, at its discretion, the whole or any component part of any product manufactured by PDi and found by PDi to be defective. If the decision is made to replace the product, PDi will exchange the model for the same model or a model similar in form and function.

As a condition to obtaining warranty service, written notification of the defective product must be received by PDi within ten (10) days of noticing the defect. Repair of said product requires it to be shipped to the PDi factory in Springboro, Ohio. All shipments shall be F.O.B. Springboro, Ohio, and all shipping and freight charges to PDi's factory shall be paid by the customer.

For information regarding authorized servicing and all other information pertaining to this warranty, please contact PDi COMMUNICATION SYSTEMS at 40 Greenwood Lane, Springboro, Ohio 45066 or phone 800-628-9870 and ask for Service.

This warranty gives specific legal rights and you may also have other rights which vary from state to state.

Exclusions from Warranty

- Products damaged by any catastrophe, accident, or from neglect, misuse, fault, improper assembly, improper maintenance, inadequate return packaging, or negligence by the customer or any third party. They will be treated as out of warranty for external cause to the Products, such as, but not limited to, failure of or faulty electric power, air conditioning, operator error, failure or malfunction of any data communications system. Such conditions will be determined by PDi at its sole unfettered discretion.
- Service and repair of accessories, apparatus, attachments or any other devices which are not PDi products or options.
- Defacing of product, revision control and PDi labeling (label alterations, serial number missing, serial number no longer discernible and serial number invalid). All serial numbers are recorded and tracked for warranty purposes.
- Unauthorized changes, modifications or alterations in or to the Products not installed by PDi.
- Damage to or loss of any programs, data, or removable storage media.
- Damage incurred during installation, relocation or removal of the Products or any accessories, apparatus, attachments or other devices.
- Normal wear.
- The furnishing of accessories or supplies.
- Damage by shipping carrier.
- Incompatibility issues.
- Damages of any kind including, but not limited to, direct or indirect damages, lost profits, lost saving, or other special incidental, exemplary or consequential damages whether for breach of contract, tort or otherwise, or whether arising out of the use of or inability to use the product, even if PDi or any distributor, dealer, or authorized service provider has been advised of the possibility of such damages, or any claim by any other party
- Damage caused by any software or application not installed at the factory.

PDi's liability under this warranty is limited to repair or replacement of defective products and parts as provided above. PDi shall not be liable for incidental or consequential damages.*

The warranty contained herein is in lieu of all other expressed or implied warranties, including any implied warranty of merchantability or fitness for any particular purpose. PDi neither assumes nor authorizes any person to assume, on its behalf, any other obligation or liability.

*Some states do not allow the exclusion of limitation of incidental or consequential damages or a disclaimer of warranties implied by law, so the above limitation or exclusion may not apply.

The information and technical data in this manual is believed accurate, but is not warranted and is subject to change without notice or obligation. PDi reserves the right to change this policy without advance notice.