

Service Manual

PDI-750B

Hospital Grade Individual Power Supply



PDi

Communication
Systems, Inc.

40 Greenwood Lane
Springboro, Ohio
45066

PH: 937-743-6010
FX: 937-743-5664

<http://www.pdiarm.com>

PDI-750B Individual AC Power Supply

Better Solutions Are Within Reach®



Graphical Symbols

This lightning flash with arrowhead symbol, within an equilateral triangle is intended to alert the user of the presence of uninsulated “dangerous voltage” within the product’s enclosure that may be of sufficient magnitude to constitute a risk of electric shock to persons.



The exclamation point within an equilateral triangle is intended to alert the user of the presence of important operating and maintenance (servicing) instructions in the literature accompanying the appliance.

This service manual contains various CAUTIONS and WARNINGS indicated by triangular warning symbols, which should be read and understood in order to minimize the risk of personal injury to service personnel and customers. The possibility exists that improper service methods may damage the equipment or result in property damage or user injury. It also is important to understand that these CAUTIONS and WARNINGS are not exhaustive. PDI could not possibly know, evaluate and advise the service industry of all conceivable methods in which service might be done or of the possible hazardous consequences of each method. Accordingly, a servicer who uses a service procedure or tool which is not recommended by PDI must first satisfy themselves thoroughly that neither their safety nor the safe operation of the equipment will be compromised by the service method selected.

Product Safety Servicing Precautions

- MODIFICATIONS** Do not attempt to modify this product in any way without written authorization from PDI. Unauthorized modifications will not only void the warranty, but may lead to your being liable for any resulting property damage or user injury.
- POWER RATING** This power supply will provide combined low voltage AC power and RF TV signal to power a hospital grade, swing arm television.
- REPLACEMENT PARTS** Parts critical to the safe operation of this television are marked with a  on schematics or drawings. Replace only with the part number specified.
- SAFETY CHECKS** This hospital grade power supply requires special safety checks before returning to service. Observe and follow the “Safety Check” section in this service manual.

Voltage	Range
INPUT	115 Volts AC
OUTPUT	28 Volts AC

PDI-750B – SPECIFICATIONS

Input	115VAC, 1A
Output	28VAC, 3A
Fuse	1A MDL
Insertion Loss (50MHz – 850MHz)	<3dB
Return Loss(50MHz – 850MHz)	>6dB

	MODEL NUMBER: PDI-750B	Document Number: PD196-054R2
	SERVICE MANUAL	Page 3 of 5

Circuit Description

Refer to the schematic.

The power supply is configured as a simple step-down transformer with a printed circuit board mounted RF diplexing network used to combine the low voltage transformer secondary voltage (approximately 28 VAC) with an RF cable TV signal. The supply's primary is fused for safety and generates approximately 100 watts of non-regulated power to a hospital grade swing arm television.



CAUTION Lethal voltage present while performing the troubleshooting procedures.

Troubleshooting Chart

SYMPTOM	DETAILS
No Power	<ol style="list-style-type: none"> 1. Verify line cord is plugged into a powered AC wall outlet. 2. Check Fuse. 3. Remove cover. Verify voltage on PWR connector. Voltage should be 28 to 30 VAC. 4. Check for voltage on J1, the RF/AC OUT jack.
Snowy Picture	<ol style="list-style-type: none"> 1. Verify RF cable TV signal is connected to J2, RF IN Jack. NOTE: If the input RF signal coax has been mistakenly connected to J1, the RF/AC OUT jack, the power supplies' AC voltage may have damaged externally connected RF passive devices reducing the cable TV signal strength. 2. Check and replace the RF printed circuit board if necessary.

Safety Checks

After the original service problem has been corrected, a check should be made of the following:

1. Always use this power supply with a television indicated for use with this supply. Operation of a television at the incorrect voltage may result in significant safety hazards.
2. Be sure that all components are positioned in such a way as to avoid possibility of adjacent component shorts. This is especially important on those units transported to and from the repair shop.
3. Never release a repair unless all protective devices such as insulators, barriers, covers, shields, strain reliefs, and other hardware have been reinstalled per original design.
4. Soldering must be inspected to discover possible cold solder joints, frayed leads, damaged insulation (including coax cable), solder splashes or sharp solder points. Be certain to remove all loose foreign particles.
5. All critical components such as fuses, flameproof resistors, capacitors, transformers, etc. must be replaced with exact factory types. Do not use replacement components other than those specified or make unrecommended circuit modifications.

	MODEL NUMBER: PDI-750B	Document Number: PD196-054R2
	SERVICE MANUAL	Page 4 of 5

6. After re-assembly of the power supply, always perform AC leakage current tests on all exposed metallic parts and the cabinet. Do not make any connection to the "RF IN" connector. Do not use a line isolation transformer during this test. Place a ground adapter on the power supply's AC plug, but leave the adapter ground floating (ungrounded). Use an AC voltmeter, having 5000 ohms per volt or more sensitivity, in the following manner: connect a 1500 ohm 10 watt resistor, paralleled by a 0.15mfd, 150VAC type capacitor between a known good earth ground (water pipe, conduit, etc.) and the exposed metallic parts, one at a time. Measure the AC voltage across the combination of a 1500 ohm resistor and 0.15mfd capacitor. Reverse the power supply AC adapter plug and repeat AC voltage measurements for each exposed metallic part. Voltage measurements must not exceed 0.15 volts RMS. This corresponds to 0.100 milliamps of AC current. Any value exceeding this limit constitutes a potential shock hazard and must be corrected immediately before returning the power supply to service .

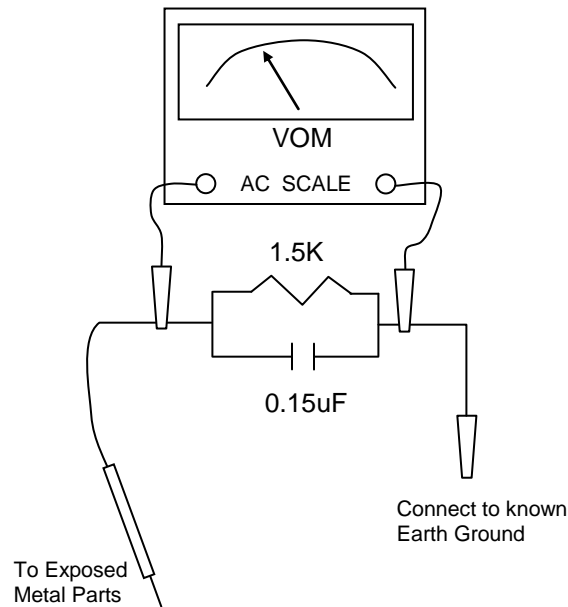

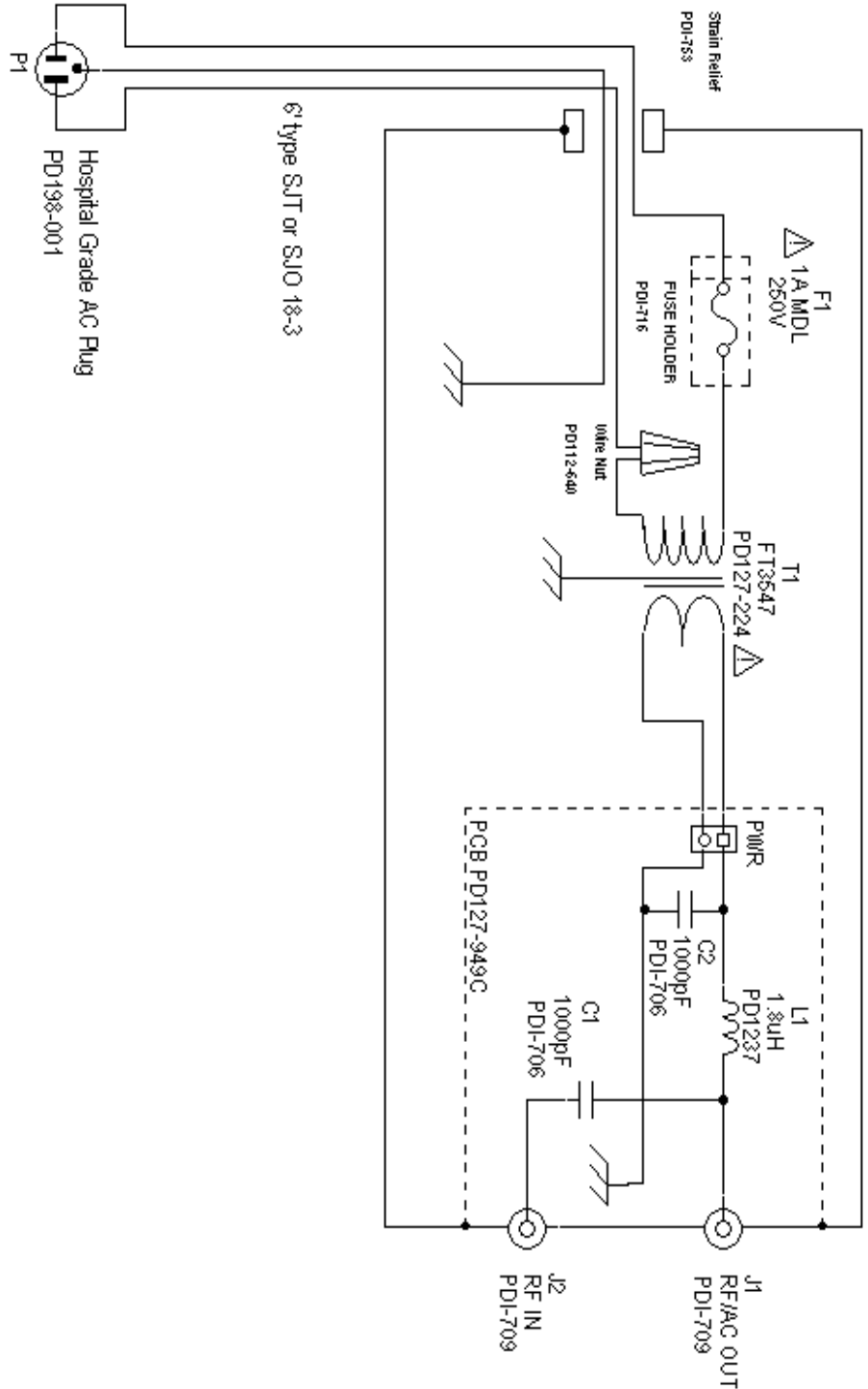

⚠ Indicates a critical component. Replace only with identical part specified.

PDI Communication Systems claims proprietary right to the material disclosed hereon. This drawing is issued in confidence for servicing information only and may not be reproduced or used to manufacture anything shown hereon without permission from PDI to the user. The information contained hereon is believed accurate, but is not warranted, and is subject to change without notice or obligation. Copyright © 2003-2004 by PDI. All rights reserved.