	MODEL NUMBER: PDI-LCD-GRID-MT	Document Number: PD196-055R7
	LCD GRIDMOUNT INSTALLATION	Page 1 of 5

PLEASE NOTE:

A primary LCD TV mount (manufactured by PDi) is required to attach the TV to this PDI-LCD-GRID-MT. This required mount must match the TV VESA mounting pattern. This mount will support up to a 40" class LCD TV or a 42" class LED TV, when properly installed.

Safety Steps:

1. Always wear safety glasses/goggles to prevent injury from debris.
2. Follow the installation/removal instructions for your existing products.

Tool List:

1. P1 or P2, Phillips screwdriver
2. 5/32 allen wrench
3. 3/16 allen wrench
4. 7/16 wrench
5. Safety glasses/goggles

Procedure

Mounting Upper Support

1. Find desired mounting location and remove adjacent tiles for a workspace.
2. Place the UPPER SUPPORT on top of the tile that the assembly will be mounted to and string the required guy-wires but DO NOT attach to UPPER SUPPORT. The support must mount across the 24" dimension of the tile. Verify correct type of guy-wire required per local building code. Determine which of the three (3) sets of mounting holes will be used to provide the best placement for the installation. Cut one of the 2-1/2" x 3-3/4" holes out of the tile and drill pilot holes (3/16" diameter) for the four (4) mounting screws.

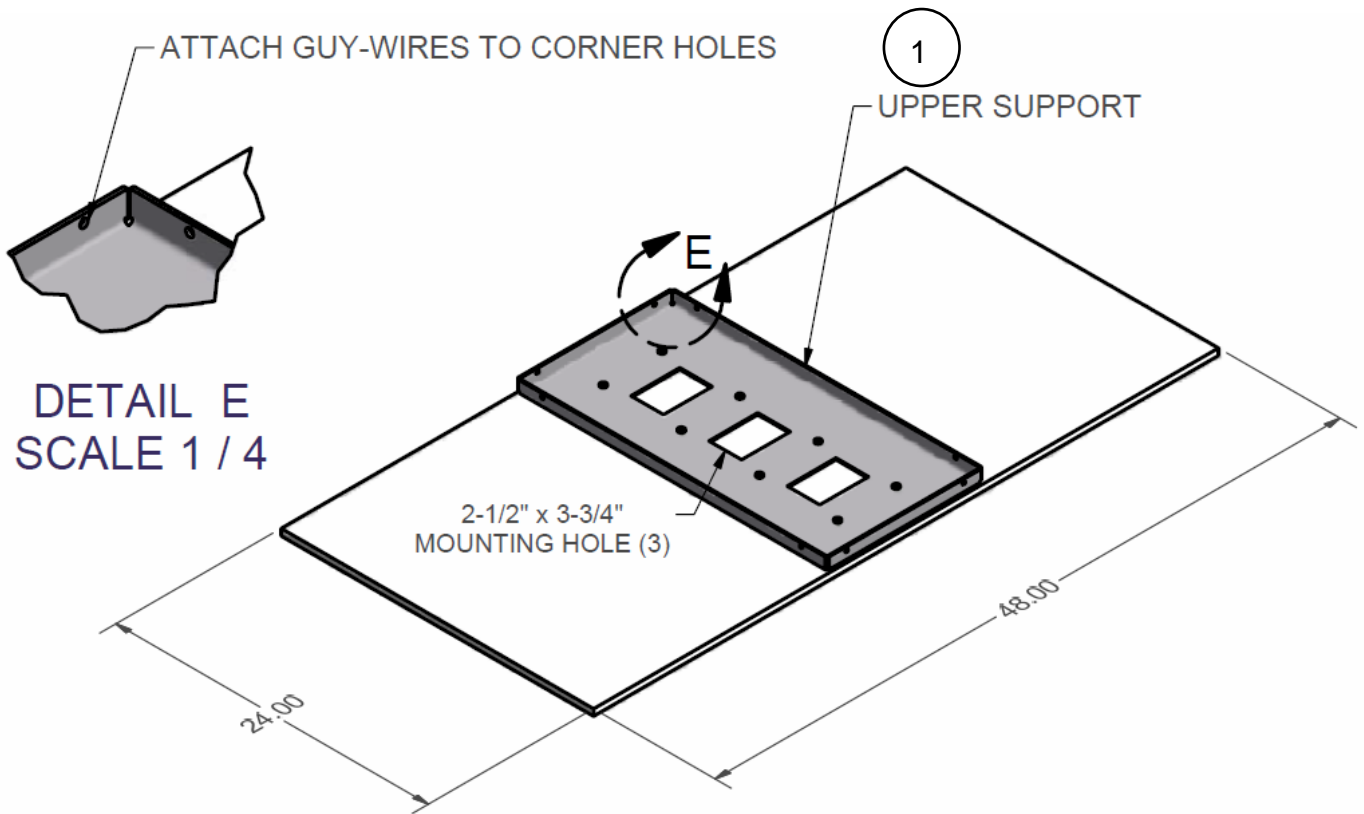

Assembling Lower Support

1. Install the PDIBHSCS 2520 62 and PDIHN 2520 per drawing and securely tighten.
2. Install PDINILN 2520 per drawing and securely tighten.
3. Install PDI-590 sleeves per drawing and apply grease to outer flange surfaces.

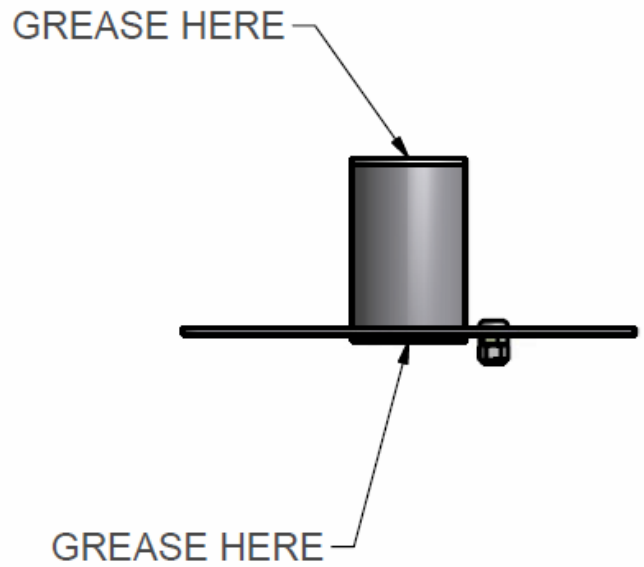
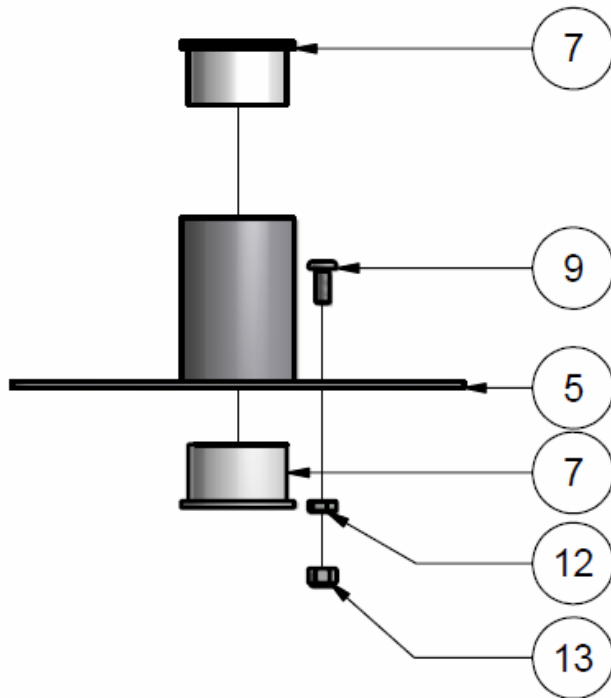

Parts List			
ITEM	QTY	PART NUMBER	DESCRIPTION
1	1	PD240-001	UPPER SUPPORT
12	1	PDIHN2520	1/4-20 HEX NUT
3	2	PD185-001	ROTATIONAL STOP COLLAR FOR LCD GRID MOUNT
5	1	PD240-002	GRID MOUNT LOWER SUPPORT ASSEMBLY
7	2	PDI-590	CMT SLEEVE
9	1	PDIBHSCS 2520 62	1/4-20x5/8 BHSCS
13	6	PDINILN2520	1/4-20 NYLOC NUT

Assembling Support Tube Assembly

1. Determine the desired mounting height for the LCD.
2. Slide one (1) STOP COLLAR over the SUPPORT TUBE and securely tighten at the desired mounting height.
3. Slide LOWER SUPPORT onto SUPPORT TUBE per drawing and install upper STOP COLLAR. Securely tighten at the desired mounting height.
4. If needed, the extra SUPPORT TUBE above the LOWER SUPPORT can be trimmed off to gain clearance in the ceiling.
 Leave at least 2" above the upper STOP COLLAR and drill a new 17/64" hole for the safety screw. The inside of the cut tube must be deburred to prevent damage to the cables.
5. Install PDIBHSCS 2520 50 and PDININ 2520 into top end of SUPPORT TUBE assembly and tighten securely as shown.
 This is a required safety screw.
6. Install PDISHCS 2520 25, with Lock-tite, into bottom STOP COLLAR and tighten securely.

PARTS LIST			
ITEM	QTY	PART NUMBER	DESCRIPTION
3	2	PD185-001	ROTATIONAL STOP COLLAR FOR LCD GRID MOUNT
5	1	PD240-002	GRID MOUNT LOWER SUPPORT ASSEMBLY
6	1	PD240-003	GRID MOUNT EXTENSION TUBE
11	1	PDIBSHCS 2520 50	1/4 -20 X 1/2 BUTTON SOCKET HEAD CAPSCREW
13	6	PDINILN2520	1/4 -20 NYLOC NUT
15	1	PDISHCS 2520 25	1/4 -20 X 1/4 SHCS

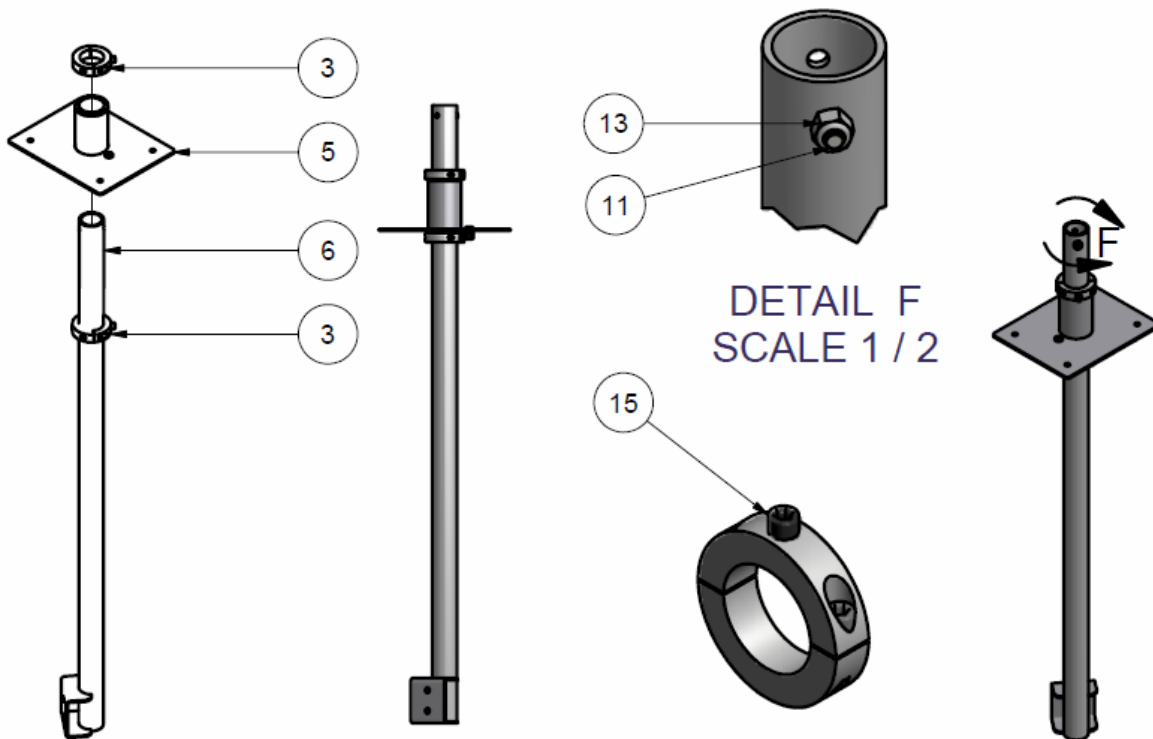

Attach the Support Tube to Ceiling

1. Insert SUPPORT TUBE assembly through hole in ceiling tile and mount with four (4) PDIPPHMS2520 125 and four (4) PDINILN 2520.
2. Be careful to not over tighten the screws and crush the tile.
3. Install guy-wires now.
4. Mount LCD TV with bracket supplied with the LCD TV set.

PARTS LIST			
ITEM	QTY	PART NUMBER	DESCRIPTION
14	4	PDIPPHMS2520200	1/4 - 20 X 2.00" PPHMS
13	6	PDINILN2520	1/4 -20 NYLOC NUT

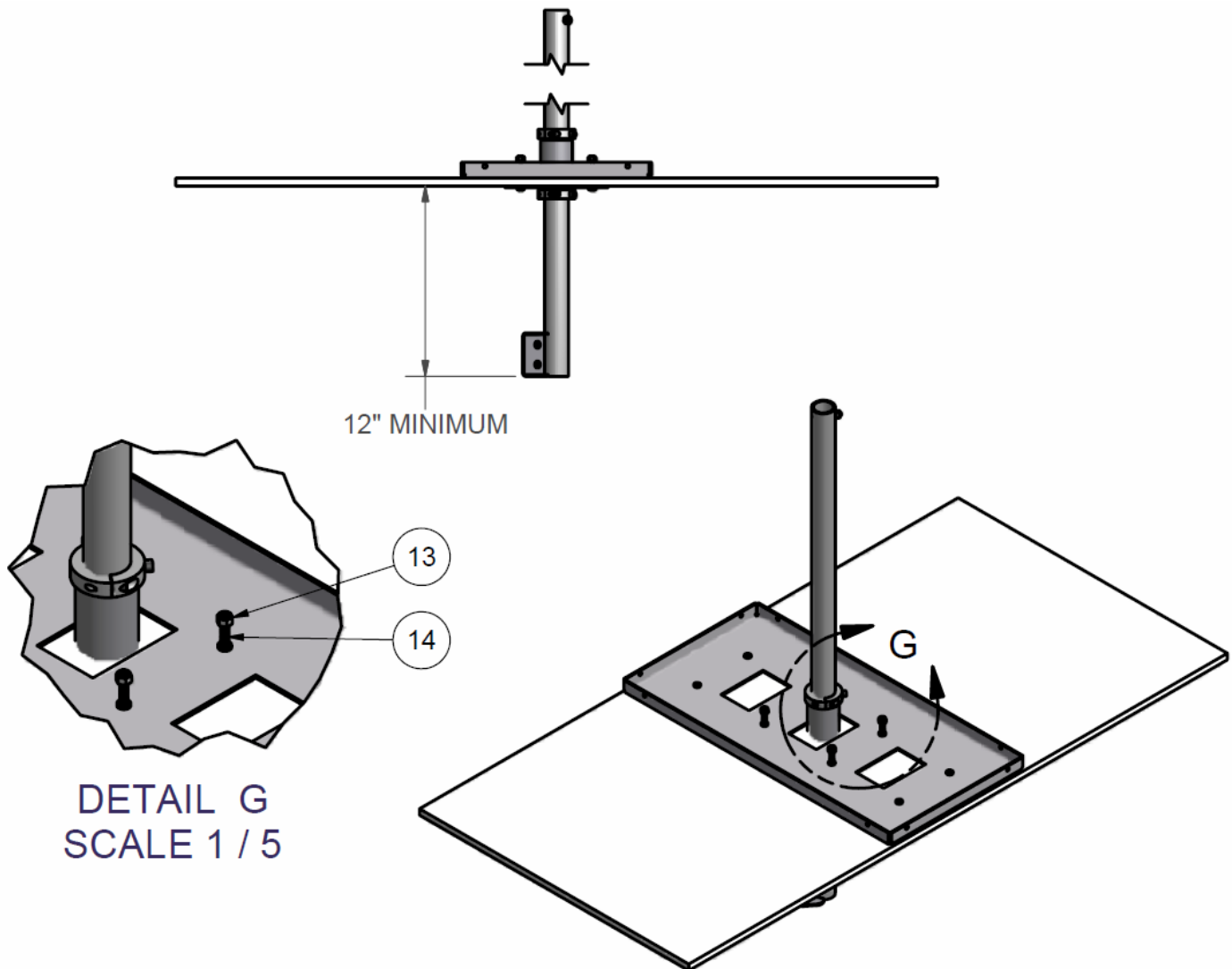

Optional Attachment of Outlet Electrical Box:

1. Select an appropriate sized single gang "OLD WORK" or "REMODELING" electrical box.
2. Cut only **ONE** of the remaining rectangular holes in the PD240-001, upper support plate, through the ceiling tile. Cut the hole size to match the electrical box.
3. Install the electrical box per the manufacturer's instructions.
4. Be careful not to over tighten the screws and crush the tile.

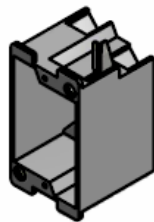
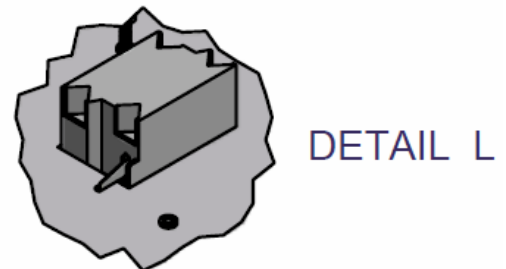
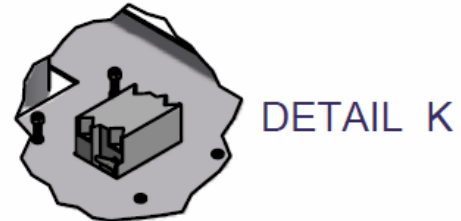
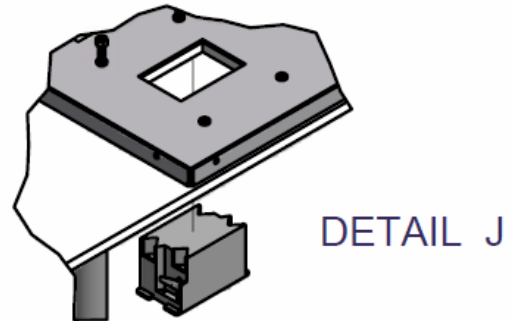
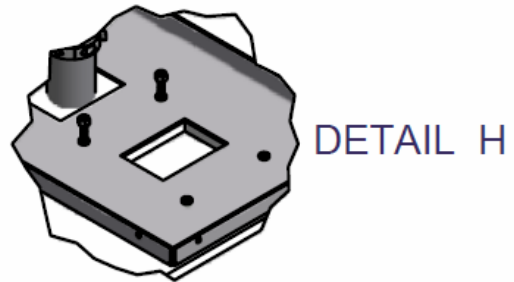

single gang
"OLD WORK" or "REMODELING"
electrical box.