

**Installation
Operating
Instructions**

PERSONA¹⁰

Hospital-Grade LCD Television Receiver



MODEL PDI-P10LCDD

PDI

Communication
Systems, Inc.
40 Greenwood Lane
Springboro, Ohio 45066

PH: 937-743-6010
FX: 937-743-5664

<http://www.pdiarm.com>

Better Solutions Are Within Reach[®]

Graphical Symbols



This lightning flash with arrowhead symbol, within an equilateral is intended to alert the user of the presence of un-insulated “dangerous voltage” within the product’s enclosure that may be of sufficient magnitude to constitute a risk of electric shock to persons.

The
of the
in the



exclamation point within an equilateral triangle is intended to alert the user presence of important operating and maintenance (servicing) instructions literature accompanying the appliance.



Important Safety Instructions

PLEASE READ AND KEEP THESE INSTRUCTIONS. OBSERVE ALL WARNINGS AND FOLLOW ALL INSTRUCTIONS CONTAINED IN THESE SAFETY INSTRUCTIONS AND THOSE ON YOUR TELEVISION. RETAIN THESE INSTRUCTIONS FOR FUTURE USE.

Electrical energy can perform many useful functions. This unit has been engineered and manufactured to assure your personal safety. However, improper use can result in potential electrical shock or fire hazards. In order not to defeat the safe-guards incorporated on this receiver, observe the following basic rules for its installation, use and servicing. Your television does not contain any user serviceable components. Removal of the cabinet cover may expose you to dangerous voltages. Refer all servicing to qualified service personnel.

1. Read these instructions.
2. Keep these instructions.
3. Heed all warnings.
4. Follow all instructions.
5. Do not use this apparatus near water.
6. Clean only with dry cloth.
7. Do not block any ventilation openings. Install in accordance with the manufacturer’s instructions.
8. Do not install near any heat source such as radiators, heat registers, stove, or other apparatus (including amplifiers) that produce heat.
9. Do not defeat the safety purpose of the polarized or grounding-type plug. A polarized plug has two blades with one wider than the other. A grounding type plug has two blades and a third grounding prong. The wide blade or the third prong is provided for your safety. If the provided plug does not fit into your outlet, consult an electrician for replacement of the obsolete outlet.
10. Protect the power cord from being walked on or pinched particularly at plugs, convenience receptacles, and the point where they exit from the apparatus.
11. Only use attachments/accessories specified by the manufacturer.
12. Use only with the cart, stand, tripod, bracket or table specified by the manufacturer, or sold with the apparatus. When a cart is used, use caution when moving the cart/apparatus combination to avoid injury from tip-over.
13. Unplug this apparatus during lightning storms or when unused for long period of time.
14. Refer all servicing to qualified service personnel. Servicing is required when the apparatus has been damaged in any way, such as power-supply cord or plug is damaged, liquid has been spilled or objects have fallen into the apparatus, the apparatus has been exposed to rain or moisture, does not operate normally, or has been dropped.





WARNING – To reduce the risk of fire or electric shock, do not expose this apparatus to rain or moisture.

WARNING – OXYGEN ENVIRONMENT: Do not use in any oxygen tent or oxygen chamber. Such use may cause a fire hazard.

Apparatus shall not be exposed to dripping or splashing and no objects filled with liquids, such as vases, shall be placed on the apparatus

Copyright, Disclaimer, and Trademarks

COPYRIGHT

PDI Communication Systems, Inc. claims proprietary right to the material disclosed in this user manual. This manual is issued for user information only and may not be used to manufacture anything shown herein. Copyright © 2000 – 2009 by PDI Communication Systems, Inc. All rights reserved.

DISCLAIMER

The author and publisher have used their best efforts in preparing this manual. PDI Communication Systems, Inc. make no representation or warranties with respect to the accuracy or completeness of the contents of this manual and specifically disclaim any implied warranties or merchantability or fitness for any particular purpose and shall in no event be liable for any loss of profit or any other damages. The information contained herein is believed accurate, but is not warranted, and is subject to change without notice or obligation.

TRADEMARKS

Manufactured under license from Dolby Laboratories. Dolby and the double-D symbol are trademarks of Dolby Laboratories. All brand names and product names used in this manual are trademarks, registered trademarks, or trade names of their respective holder. *PDI* and *Better Solutions Are Within Reach* are registered trademarks of PDI Communication Systems, Inc., Springboro, Ohio.

Regulatory Information

FCC

This equipment has been tested and found to comply with the limits for a Class B digital device, pursuant to part 15 of the FCC Rules. These limits are designed to provide reasonable protection against harmful interference when the equipment is operated in a residential or commercial installation. If this equipment does cause harmful interference to radio or television reception, which can be determined by turning the equipment off and on, the user is encouraged to try to correct the interference by one of more of the following measures:

- Re-orient or relocate the receiving antenna.
- Increase the separation between the equipment and receiver.
- Connect the equipment into an outlet on a circuit different from that to which the receiver is connected.
- Consult the dealer or an experienced radio/TV technician for help.

Underwriters Laboratories



The model PDI-P10LCDD Hospital Grade LCD TV is a specialized LCD television and should be installed to National Electrical Code specifications.

This device is safety tested and listed by the Underwriters Laboratories as a product suitable for use in health care facilities in both the United States and Canada.

Installation Precautions

1. Any changes or modifications in construction of this television, which are not expressly approved by the party responsible for compliance, could void the user's authority to operate the equipment.
2. Use only a power source from a CSA Certified / UL Approved Class 2 Power Supply suitable for use in a Health Care Facility. This TV will operate on either DC or AC voltage, range 18 to 32 volts.
3. THIS INSTALLATION SHOULD BE MADE BY A QUALIFIED SERVICE PERSON AND SHOULD CONFORM TO ALL LOCAL CODES. READ AND FOLLOW THE SAFETY INSTRUCTIONS BEFORE ATTEMPTING THIS INSTALLATION.
4. NOTE TO CATV INSTALLER: This reminder is provided to call the CATV system installer's attention to Article 820-40 of the NEC that provides guidelines for proper grounding and, in particular, specifies that the cable ground shall be connected to the grounding system of the building, as close to the point of cable entry as practical.



**USE RECOMMENDED
COAX. USE OF ANY
OTHER CABLE
NUMBER IS NOT
RECOMMENDED.**

5. COAX CABLE SPECIFICATION: Coax cable selection is critical when the TV is powered from a central power supply. Due to long coax cable runs encountered in hospital installations, coax cable employing a solid copper center conductor and copper shield is required. Cable run lengths MUST NOT exceed 150 feet. Required coaxial cable numbers include Alpha 9804C (non-plenum), Belden 9248 (non-Plenum), West Penn 806 (non-Plenum), or West Penn 25806 (Plenum), which have been tested with coax-powered televisions.
6. CLEANING: Clean the exterior of this television by removing dust with a lint-free cloth. For further cleaning, use a soft cloth or paper towel dampened with water. CAUTION: To avoid damage to the surface of the television, do not use abrasive or chemical cleaning agents.
7. DISINFECTING: Do not immerse this TV, rather clean with a soft damp cloth. To avoid damage to the surface of the television, test a small portion of the TV's cabinet with any new disinfectant to verify that the disinfectant will not discolor or soften the enclosure.
8. **WARNING:** To avoid the hazards of fire or electrical shock, DO NOT expose this television to rain or moisture.
9. **WARNING OXYGEN ENVIRONMENT:** Do not use in any oxygen tent or oxygen chamber. Such use may cause a fire hazard.



Contents

- Graphical Symbol2
- Important Safety Instructions2
- Copyright, Disclaimer, and Trademarks3
- Regulatory Information3
- Installation Precautions4
- Contents5
- About the PERSONA 106
- Installing TV on Suspension Arm7
- Control Panel.....9
- Earphone Operation10
- Remote Control10
- On Screen Menu Tree.....11
- Service Levels (Tiers).....12
- Picture12
- Sound14
- Channels16
- Features22
- CLONING27
- FAQ – Frequently Asked Questions.....29
- APPENDIX A – Installation on Other PDI-508C Arms30

About the PERSONA 10

This television is specifically designed for entertainment purposes and for use in a hospital, a nursing home, a medical-care center, or a similar health-care center in which installation is limited to a non-hazardous area in accordance with the National Electrical Code, ANSI/NFPA 70.

This user's guide has been designed for both the TV installer and TV Rental Representatives. It identifies the features of the PERSONA 10 and describes how to program the TV using an infrared (IR) remote control.

Programming is the process of selecting from among the many features of the PERSONA 10 television. It is also the process of adding and removing channels from the three service levels this TV provides.

Please read through this guide carefully, with a PERSONA 10 TV in front of you, as you begin the process of learning how to program these televisions. Also keep the guide handy, so you can refer to it, for future programming changes. The information in this guide describes each of the main SETUP MENU items:

- Service Level
- Channel Setup (Programming)
- Features
- Picture Adjustment
- Sound Setup

Installing TV on Suspension Arm

The PERSONA 10 is designed to attach to a wall mounted suspension arm capable of supporting a television weighing 7 pounds. The single coaxial cable on top of the unit is used to supply either low voltage AC or DC power (range 18 to 32 volts) and the RF signal to the television. The USB cable provides cloning capability.

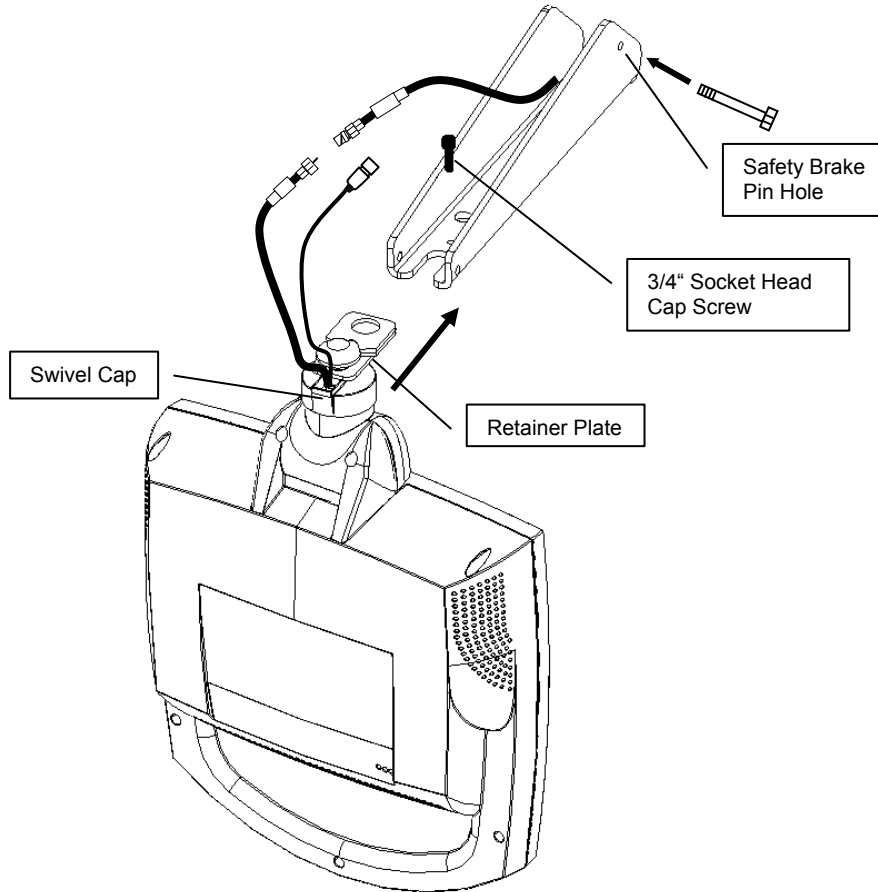

DANGER: ARM RECOIL HAZARD The safety brake pin must remain in the SAFETY BRAKE PIN HOLE whenever the television set is removed from the arm or when the arm is removed from the wall bracket to prevent the arm from springing open.

CAUTION: DO NOT REMOVE the **WHITE PLASTIC CAP** from the swivel assembly. This swivel assembly is factory preassembled and adjusted. There is no need to remove the cap.

IMPORTANT: These instructions detail installing the TV onto the PDI-508C-7 suspension arm. This arm is configured specifically for this television. The PDI-P10LCD TV may be installed on other PDI-508C arms. Please refer to Appendix A of this document for detailed instructions for this case.

INSTALLING THE TV TO THE PDI-508C-7 SUSPENSION ARM

1. Remove and save the $\frac{3}{4}$ " Socket Head Cap Screw from the plastic "H" clip. Remove the plastic "H" clip and discard.
2. Remove the two nose cover retainer screws. Raise the metal nose cover and slide the television completely into the arm's clevis swivel retainer plate should rest of the arm and the plastic swivel (see picture on previous page).
3. Align the retainer plate's mounting arm mounting hole. Thread the $\frac{3}{4}$ " Cap Screw through the retainer the arm's nose. Tighten.
4. The coax cable in the nose of the joined with the coax cable from the Wrench tighten the connection and cover by sliding the plastic boot sections into mating position.

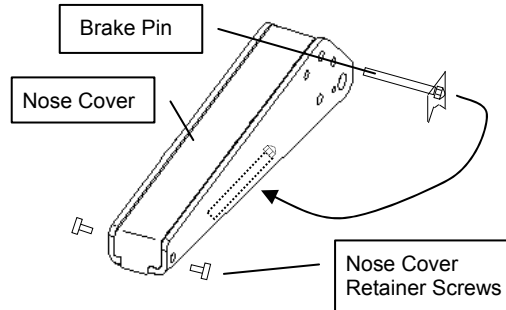

hole over the Socket Head plate and into

arm should be television.



IMPORTANT: Finger tightening of this cable connection will result in reliability problems later. Because the TV draws its power current through this connection, eventually the finger-tightened connection will loosen. Wrench tighten all "F" fitting connections!

5. Remove the safety brake pin, see picture above, from the parking brake hole, reattach the acorn nut to the pin, and store the assembly inside the nose of the arm by attaching it to the coax cable using the attached plastic clip. NOTE: Do not store the safety brake pin inside the 400 series arm nose. However, the pin should be saved for future removal of the TV from the Arm or removal of the Arm from the wall bracket.
6. Dress both coax and USB cables inside the arm's nose. Close the metal nose cover onto the nose. Reinstall the two nose cover retainer screws.
7. Attach three sets of plastic arm covers (start with long "nose cover" section):

- a. Assemble supplied spring pins into one of the arm cover halves. Pins should be installed into one cover side only.
- b. Position the Arm Cover halves around the arm's nose section. Align exposed pins with the open holes in the second cover half.
- c. Squeeze the two halves together. When the halves are properly installed there should only be a thin seam visible where the halves meet.
- d. Repeat steps a, b, c for the elbow covers and base covers.

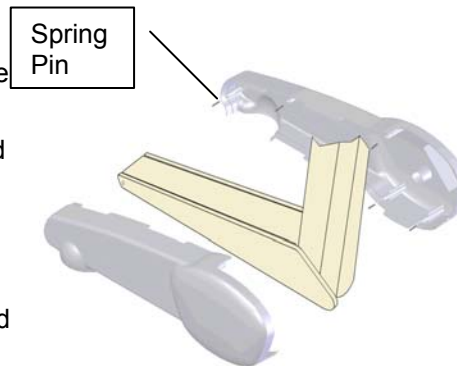

8. Connect the coax cable at the base of the arm to the wall bracket "F" fitting and wrench tighten. Cycle the arm once or twice to check for free movement.

Control Panel

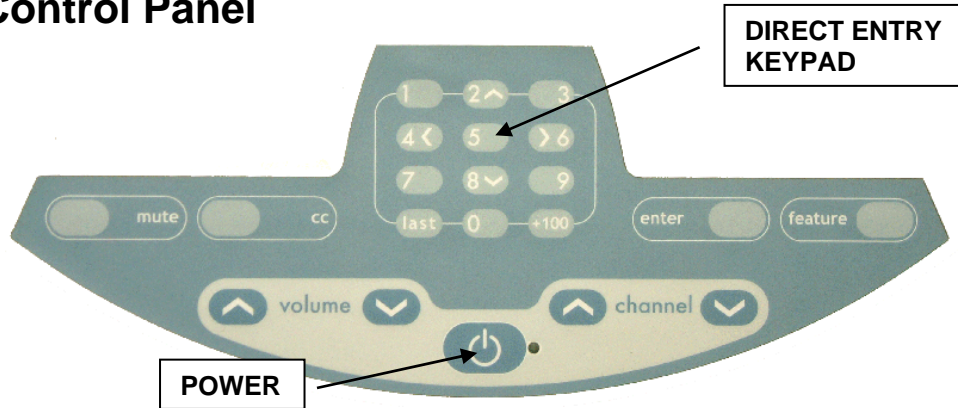

The easy to clean membrane control panel located below the display contains 9 large easy to read buttons and a numbered “direct entry” keypad for both channel and cursor control. The 5 lower buttons are used to turn the TV ON or OFF, change channels and raise or lower the sound volume.

In addition to the Channel Up and Down buttons, the numbered “direct entry” keypad may be used to directly enter the channel desired for viewing. If the channel entered using this keypad is **not** programmed into the current Service Level (see sections following on “Service Levels” and “Channels”) and the feature “Channel Memory Override” is disabled, the symbol “[X]” will be displayed in red in place of the channel number, and the channel will not change.

The “2”, “4”, “6” and “8” buttons on the direct entry keypad are also used for cursor positioning on televisions used in computer control applications.

The “feature” button displays the current screen mode of the current channel.

The “enter” button displays the program information for the current channel.

The “cc” button alternately activates and deactivates program closed captioning. Note: Not all programs offer closed captions. Pressing the button may not immediately result in the display of any captions.

The “mute” button will mute the TV audio. The speaker symbol and red X will then appear on screen. Pressing the button again or pressing the volume up or volume down buttons will enable the TV audio and remove the mute symbol from the screen.

BUTTON FUNCTION SUMMARY

POWER	Turns the TV ON or OFF.
VOLUME	Increase or decrease the TV volume.
CHANNEL	Changes the viewed channel up or down.
ENTER	Displays channel program information.
MUTE	Mutes TV audio.
CC	Activates or deactivates closed captions.
FEATURE	Displays program screen mode.
NUMBERS	Direct channel entry.



PD108-005C Earphone

Earphone Operation

Inserting an earphone in the “earphone” jack hole located on the right side of the cabinet will allow silent operation of the TV. The speaker will be shut OFF and all program audio will be available through the earphone. Remove the earphone to enable the internal TV speaker.



PD108-112 Mono Headset

The sound delivered to a connected earphone can be either mono or stereo and is set accordingly in the “Sound” menu.

PDI offers two Mono styled earphones; PD108-005C single earphone or the PD108-112 dual ear headset. Additional second party stereo headphones can also be used.



A remote control is **NOT** packaged with each TV. The remote control must be ordered separately.

Remote Control

The PERSONA 10 requires a remote control part number PD108-412 to program the set. You will **NOT** find a remote control packed with the television. The remote control is an available option and would be shipped separate from the television.

The remote control has a limited range to prevent dual programming of an adjacent room TV. Stand within 3 feet from the front of the TV to use the remote control.

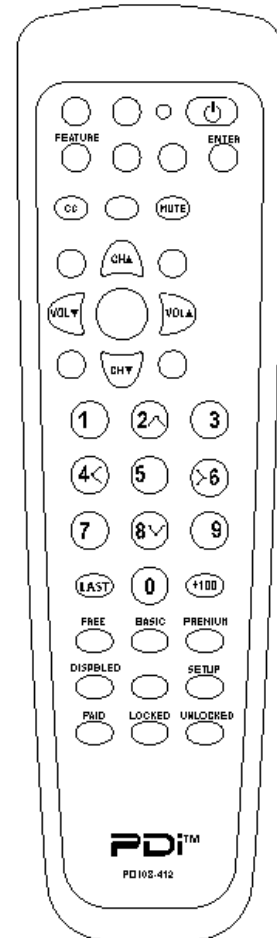

On Screen Menu Tree

The TV is programmed using the Menus. A programming remote control is required to perform all TV setup menu adjustments including programming channels. The remote control is NOT included with the TV and must be ordered separately. Order programming remote control PD108-412.

1. Press the SETUP button on the IR remote control to display the main SETUP menu.
2. Press the CH▲ or CH▼ buttons to select a menu item.
3. Enter or Adjust the menu item using the VOL▲ or VOL▼ buttons.
4. Press the SETUP button on the IR remote control to return to the preceding menu.

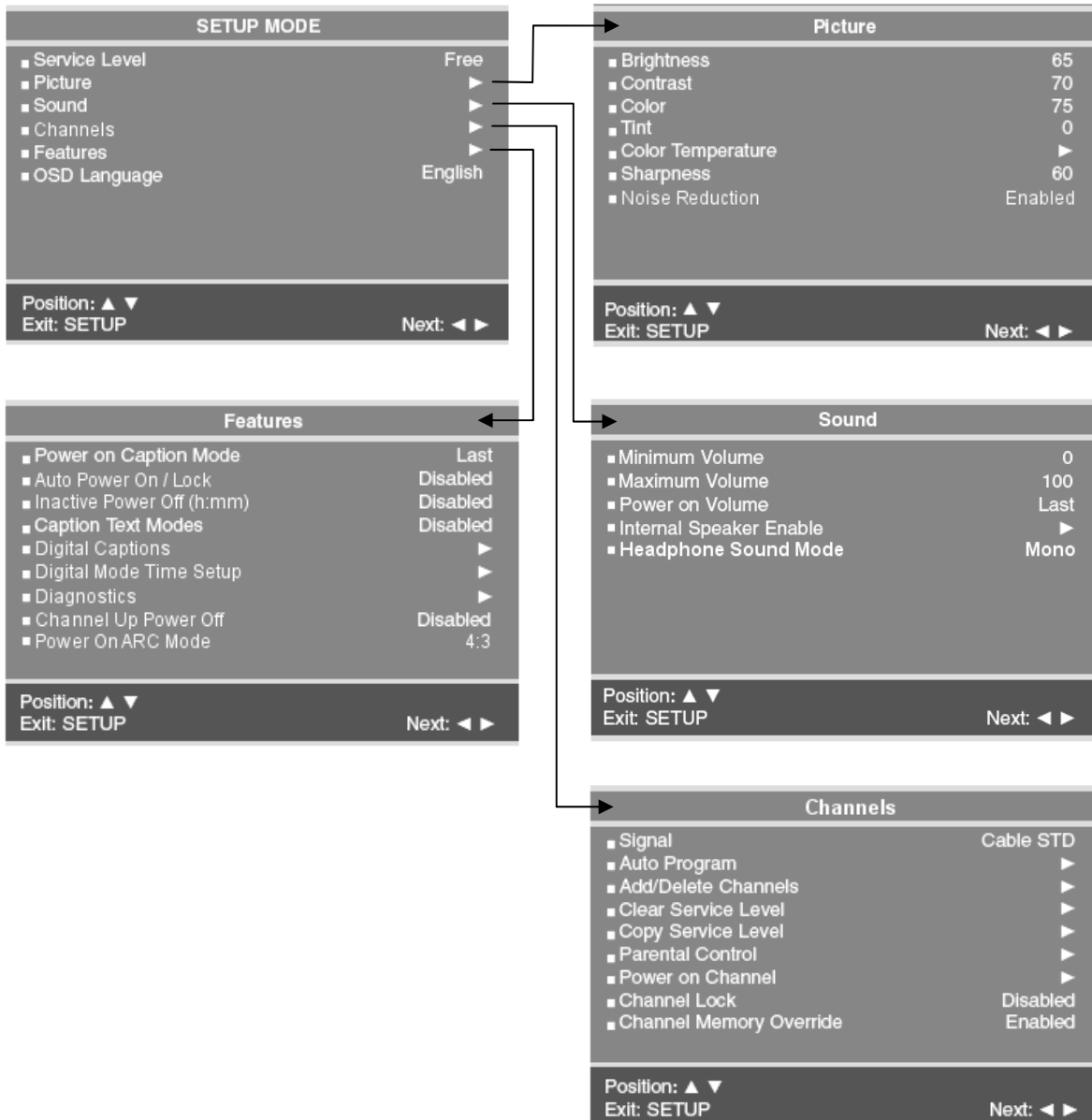

Service Levels (Tiers)

The TV can be configured with 3 different banks of channels called Service Levels. The Service Levels are named “Free, Basic, and Premium”. Each Service Level can be programmed with any combination of channels. For example, a hospital usually elects to dedicate one of the service levels for Pediatrics and another for Maternity since additional or banned channels may be found in either location that would not be normally shown to the general patient population. A DISABLED service level, is available, yet does not display any channels, rather a disabled message on the TV’s screen.

NOTE: To prevent direct entry of non-programmed channels using the keypad, the feature “Channel Memory Override” must be disabled.

To change a Service Level.

1. Press the SETUP button to display the MENU.
2. Press the CH▲ / CH▼ buttons to highlight the Service Level item.
3. Press the VOL▲ / VOL▼ button to select the desired service level.
4. Press the SETUP button to exit.

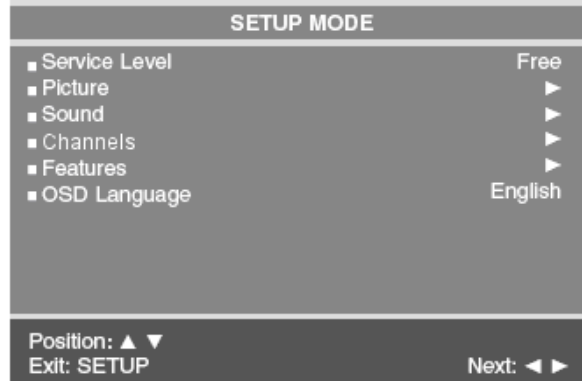

NOTE: If a Service Level is selected that is empty and has not been programmed with channels, a warning message will be displayed on the TV stating “No Channels Available, Please Contact a TV Representative.” After 15 seconds the TV will shut itself off to conserve power. To eliminate this message switch the TV to a Service Level that has been programmed with channels.

Picture

Adjustment of picture Brightness, Contrast, Color, Tint, Color Temperature and Sharpness is available to customize the levels you prefer using the on-screen menus.

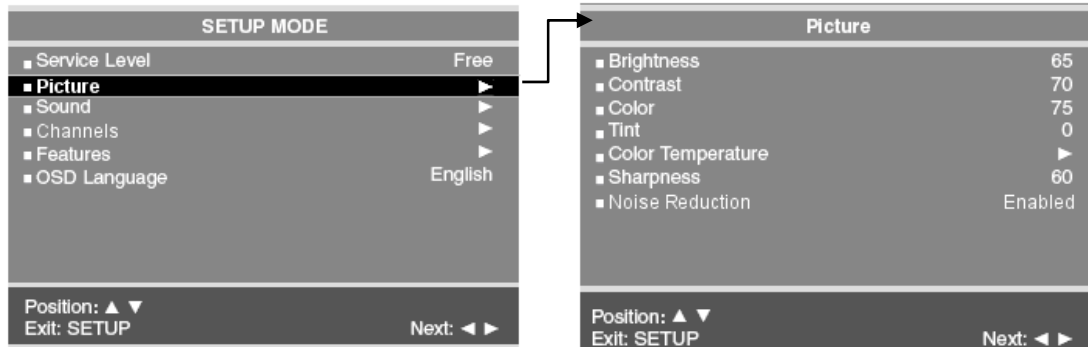

1. Press the SETUP button to display the SETUP MODE menu.
2. Select the Picture menu item.
3. Press the CH▲ / CH▼ buttons to highlight the desired picture item – Brightness, Contrast, Color, Tint or Sharpness.
4. Adjust the picture item using the VOL▲ / VOL▼ buttons to the desired level.
5. Press the SETUP button to store the picture values.

Color Temperature

The color temperature menu adjusts the color balance of the picture. “Standard”, “Reddish”, “Greenish”, “Bluish” color temperatures are available for selection; however the individual colors are not adjustable. The “USER” setting allows individual adjustment of each of the TV’s primary colors. The color temperature setting is best set using a calibrated signal source capable of generating a test signal containing both pure white and pure black picture components.

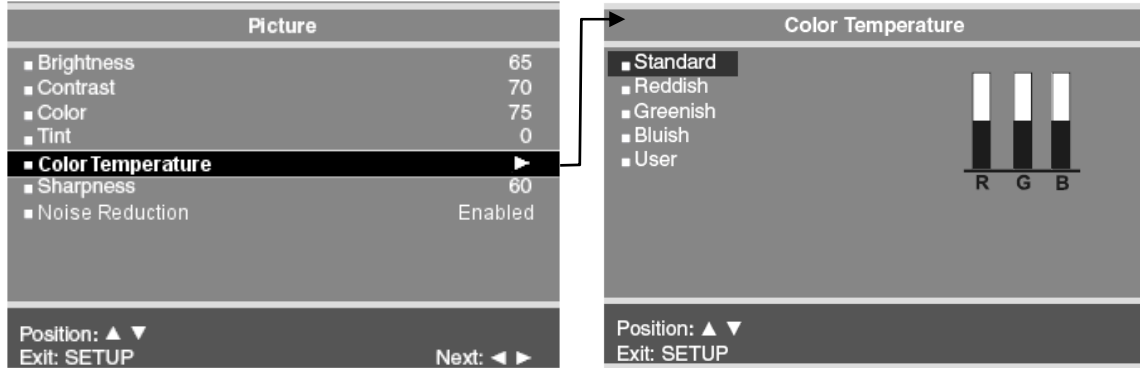

Noise Reduction

Additional picture improvement may be achieved by enabling the Noise Reduction function found in the Picture menu.

1. Press the SETUP button to display the SETUP MODE menu.
2. Select the Picture menu item.
3. Press the CH▲ / CH▼ buttons to highlight the Noise Reduction.
4. Use the VOL▲ / VOL▼ buttons to alternate, Enable or Disable.
5. Press the SETUP button to return to the previous menu.

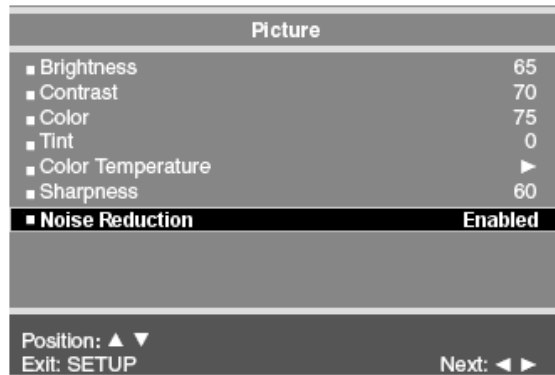

Sound

The Sound menu allows precise adjustment of several parameters.

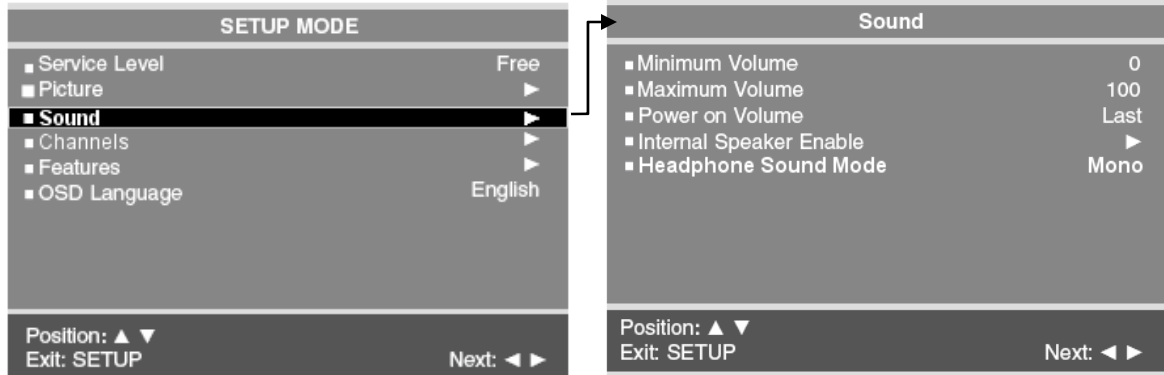

1. Press the SETUP button to display the SETUP MODE menu.
2. Press the CH▲ / CH▼ buttons to highlight the Sound menu item.
3. Use the VOL▲ / VOL▼ to display the Sound Menu.

Minimum Volume

Sets the minimum volume level the TV can reach. Setting this to any value other than 0 guarantees that some level of sound will always be heard when the TV is operating.

1. In the Sound menu, press the CH▲ / CH▼ button to select Minimum Volume.
2. Press the VOL▲ / VOL▼ button to select your preferred minimum volume with the TV turns on.
3. Press the SETUP button to return to the preceding menu.

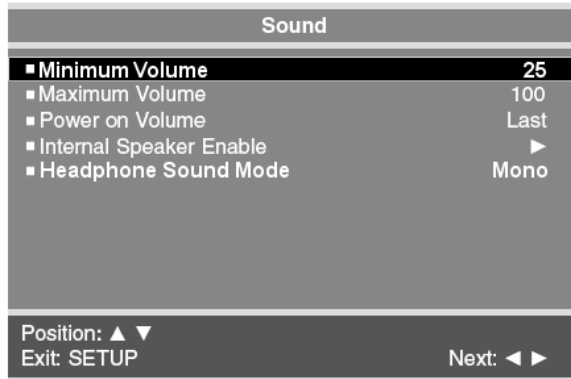

Maximum Volume

Sets the maximum volume level the TV can reach.

1. In Sound menu, press the CH▲ / CH▼ button to select Maximum Volume.
2. Press the VOL▲ / VOL▼ button to determine your preferred maximum volume allowed.
3. Press the SETUP button to return to the preceding menu.

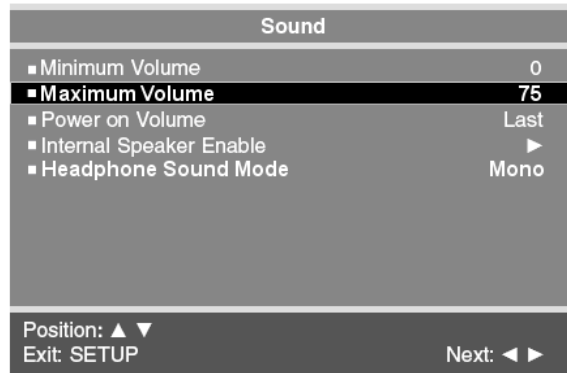

Power on Volume

Sets the initial volume for the TV upon powering on. Once the TV is on, the volume can be set to any allowable level. NOTE: If “Power on Volume” is set to LAST, and physical power is removed, the TV will power on with a volume of zero.

1. In Sound menu, press the CH▲ / CH▼ button to select Power on Volume.
2. Press the VOL▲ / VOL▼ button to determine your preferred volume when the TV turns on. Setting the level to LAST causes the TV to remember the last volume level used by the TV prior to turning off.
3. Press the SETUP button to return to the preceding menu.

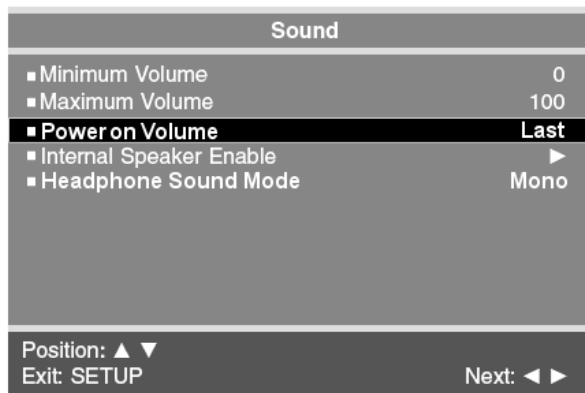

Internal Speaker Enable

The speaker's inside the TV's cabinet can be turned on or off for each TV Service Level. Note: Sound to the earphone jack remains on at all times.

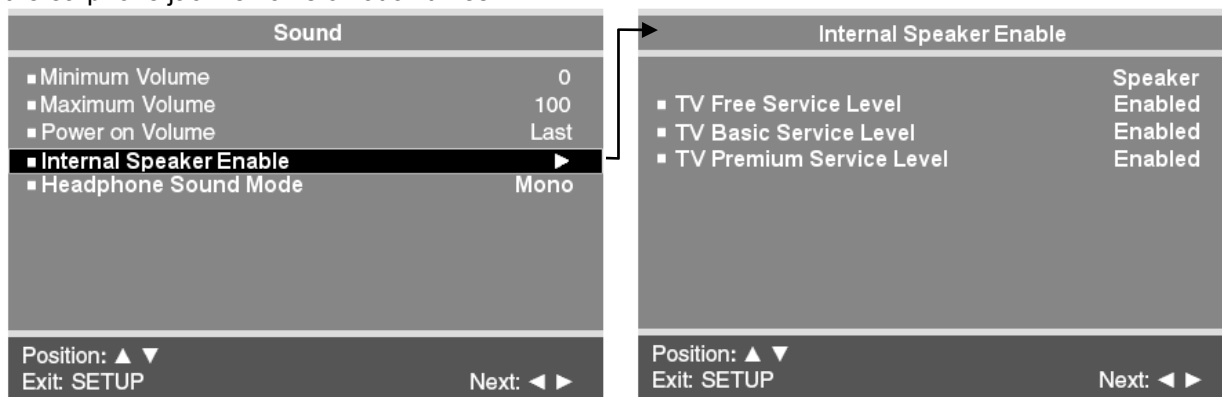

1. In the Sound menu, press CH▲ / CH▼ button to select the Internal Speaker Enable menu item.
2. Press the CH▲ / CH▼ button to select the desired Service Level.
3. Press VOL▲ / VOL▼ to select Disable or Enabled.
4. Press the SETUP button to return to the preceding menu.

Headphone Sound Mode

The earphone jack sound can be used with either a mono (single ear) or stereo (dual ear) style.

1. In the Sound menu, press CH▲ / CH▼ button to select the Headphone Sound Mode menu item.
2. Press VOL▲ / VOL▼ to select Mono or Stereo.
3. Press the SETUP button to return to the preceding menu.

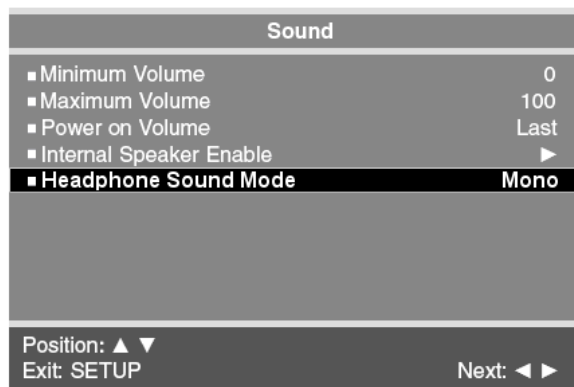

Channels

The TV offers three different programmable channel banks or Service Levels. A programming remote control is required to perform all TV setup adjustments including programming channels. The remote is **NOT** included with the TV and must be ordered separately – one remote is capable of programming an entire hospital of televisions. Please order programming remote control part number PD108-412.

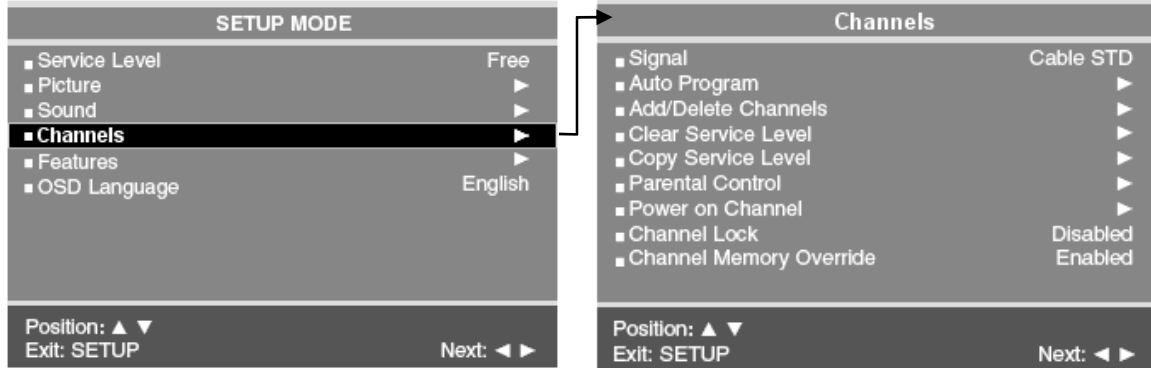

1. Press the SETUP button to display the SETUP MODE menu.
2. Press the CH▲ / CH▼ button and select Channels.
3. Press VOL▲ / VOL▼ to select.

Signal

Four different tuning types are available depending upon the healthcare facilities signal style. Selection of the correct signal type is required for the TV to recognize all possible channels and before any channel programming can begin.

1. From the SETUP menu select channels.
2. Press the CH▲ / CH▼ button to select Signal.
3. Press VOL▲ / VOL▼ to select Air, Cable STD, Cable IRC or Cable HRC. NOTE: Most hospitals use the Cable STD signal style.
4. Now perform Auto Program or Add/Delete Channels to adjust the channels.

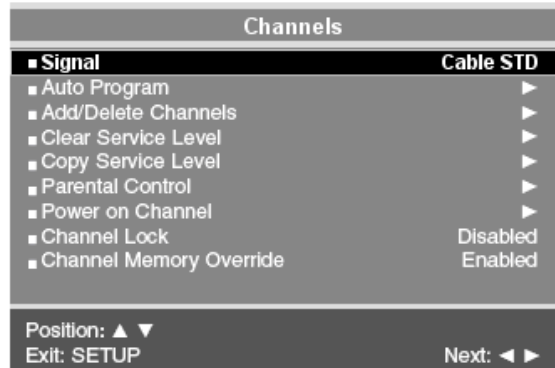

Auto Program

The TV automatically scans each available channel for activity. Channels that display activity are memorized into the selected Service Level.

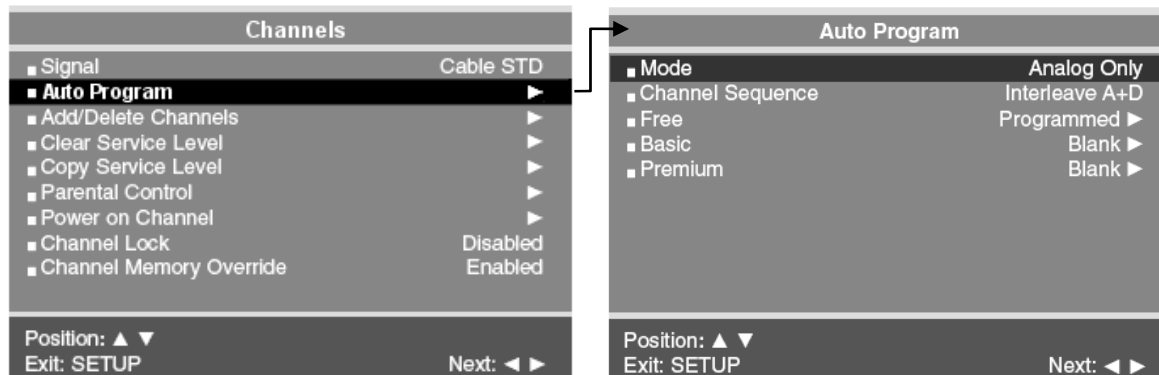

1. From the Channels Menu select Auto Program.
2. Press the CH▲ / CH▼ button to select Mode.
3. Press VOL▲ / VOL▼ to set the scope of channel scanning.
 Analog Only: TV searches for analog channels only.
 Digital Only: TV searched for digital channels only.
 Analog and Digital: TV searches for both analog and digital channels.
4. Press the CH▲ / CH▼ button to select the Channel Sequence menu item.
5. Press VOL▲ / VOL▼ to set the Channel Sequence in which the channels are displayed after searching. Most hospitals use Interleave A+D.
 Interleave A+D: In the order of channel number regardless of the system.
 All A then D: Digital channels are displayed after all analog channels.
6. Press the CH▲ / CH▼ button to select the Service Level you wish to program. The menu displays the current programming status of each level as either Programmed or Blank. NOTE: A Programmed service level can also be re-programmed if desired.
7. Press the VOL▲ button to start auto programming.
8. A confirmation menu will appear before proceeding. Press either the CH▲ to start auto programming. Press CH▼ to cancel the operation. The TV will now search all available channels. Auto programming requires several minutes to complete. NOTE: Digital channel auto programming may take longer than 10 minutes to complete.
9. Press the SETUP button to return to normal TV viewing.

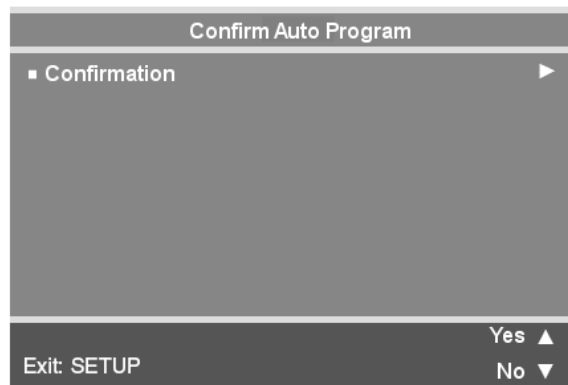

Add / Delete Channels

Individual analog TV channels that are missing can be manually added to a Service Level. Or, analog TV channels that require deletion can be manually removed from a Service Level. Digital channels found during Auto Programming can be enabled or disabled in each service level.

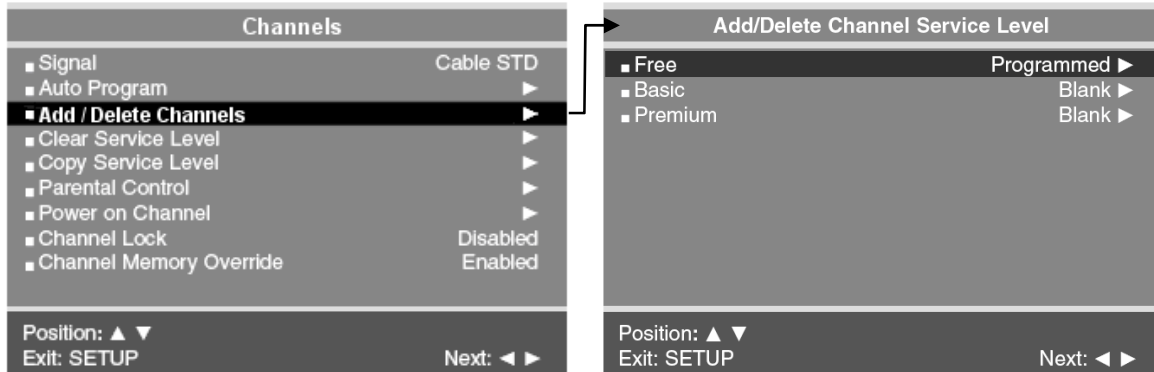

1. From the Channels menu press the CH▲ / CH▼ button to select Add/Delete Channels. Press VOL▲ / VOL▼ to select.
2. Press the CH▲ / CH▼ button to select the Service Level you wish to add or delete channels.
3. Press VOL▲ / VOL▼ to enter the Add/Delete Channels menu for that Service Level.
4. Press the CH▲ / CH▼ button to select Analog Channel.
5. Press VOL▲ / VOL▼ to scroll through every available channel. The channel number changes to indicate the current channel viewed.
6. Press the CH▲ / CH▼ button to select Add/Delete Analog Channel.
7. Press VOL▲ / VOL▼ to alternately Add or Delete the current Analog Channel from the Service Level.
8. Press the CH▲ / CH▼ button to select Enable/Disable Digital Channel.

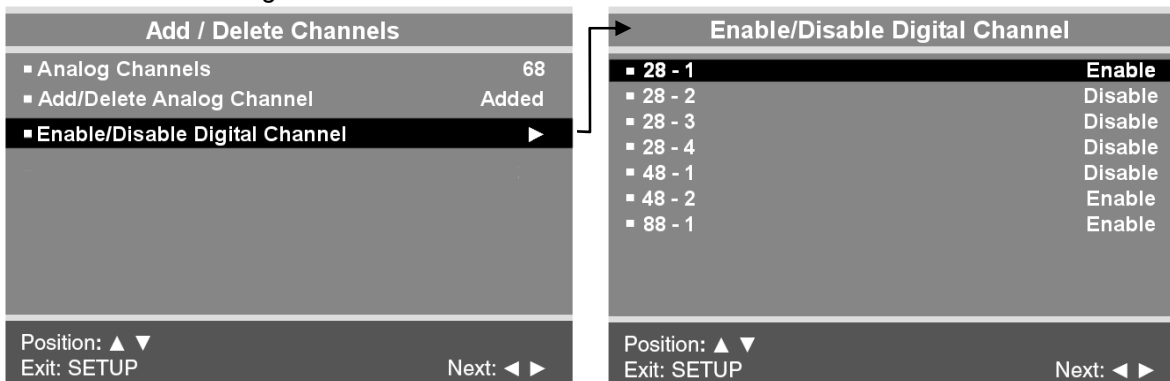

9. A listing of all digital channels found during Auto Programming will be displayed. NOTE: If the Enable/Disable Digital Channels states "No Channels", either the TV did not locate any channels during Auto Programming or the Mode was set to "Analog Only" during Auto Programming.
10. Press the CH▲ / CH▼ button to select a Digital Channel.
11. Press VOL▲ / VOL▼ to alternately Enable or Disable the current Digital Channel from the Service Level.

12. Press the SETUP button to return to the previous menus.

Clear Service Level

Empties a service level of all programmed channels leaving it Blank.

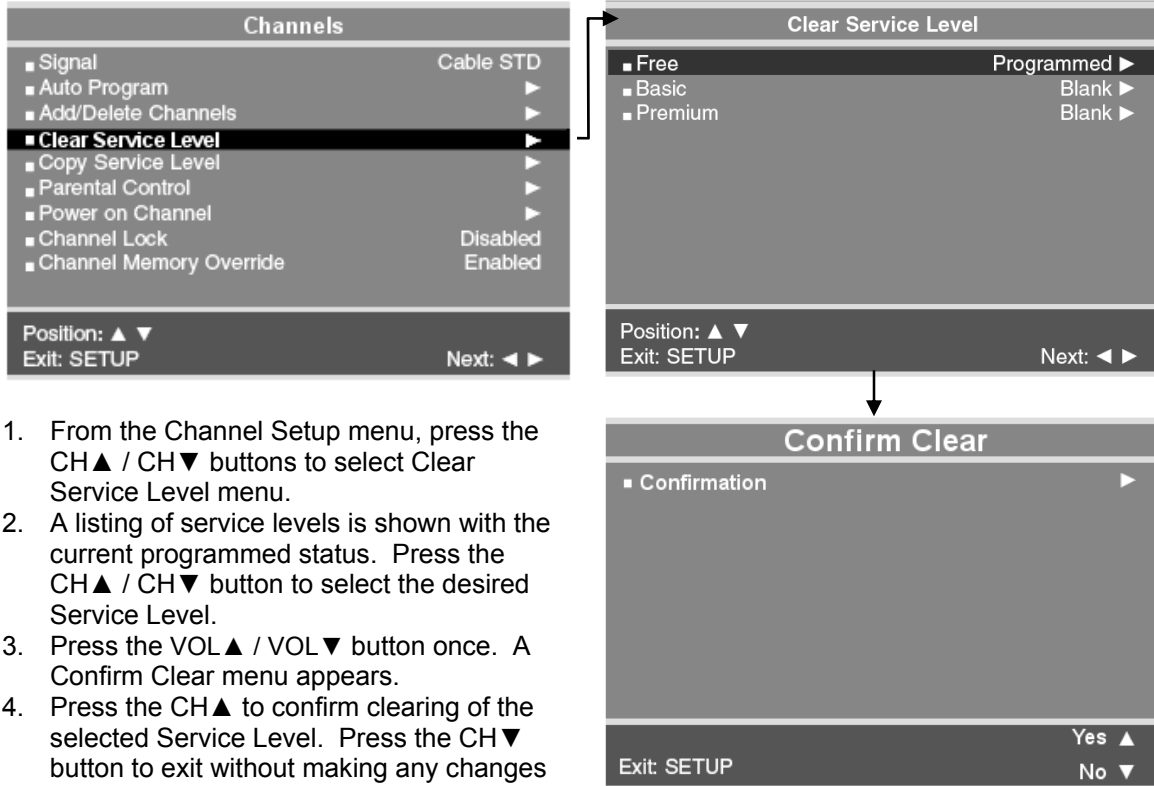

1. From the Channel Setup menu, press the CH▲ / CH▼ buttons to select Clear Service Level menu.
2. A listing of service levels is shown with the current programmed status. Press the CH▲ / CH▼ button to select the desired Service Level.
3. Press the VOL▲ / VOL▼ button once. A Confirm Clear menu appears.
4. Press the CH▲ to confirm clearing of the selected Service Level. Press the CH▼ button to exit without making any changes to the selected Service Level.
5. Press the SETUP button to return to the preceding menu.

Copy Service Level

Copies one service level to another.

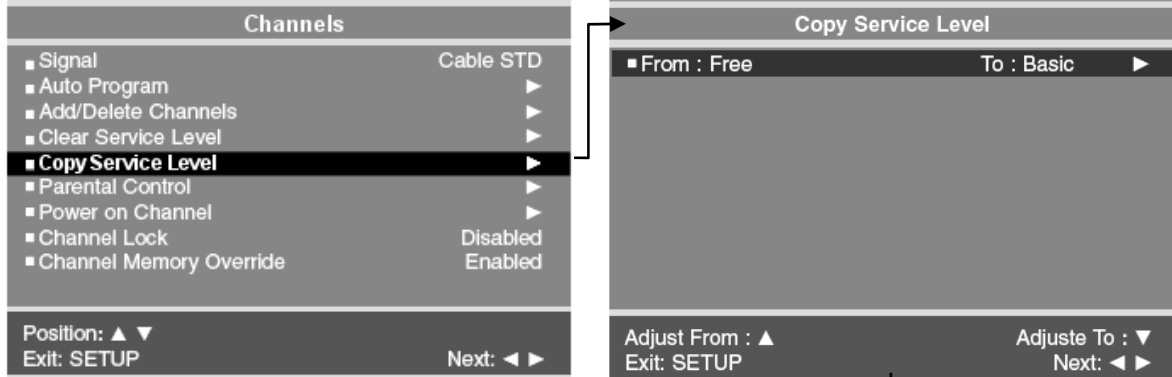

1. From the Channel Setup menu, press the CH▲ / CH▼ buttons to select Copy Service Level menu. A Copy Service Level menu appears and shows a source (From) and destination (To) Service Level.
2. Press the CH▲ button to adjust the From Service Level.
3. Press the Press the CH▼ button to select the To Service Level.
4. Press the VOL▲ / VOL▼ button once. A Confirm Copy menu appears.
5. Press the CH▲ to confirm clearing of the selected Service Level. Press the CH▼ button to exit without making any changes to the selected Service Level.
6. Press the SETUP button to return to the preceding menu.

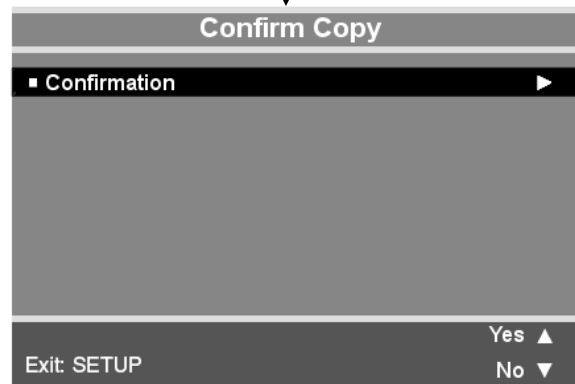

Power on Channel

The TV can be preset to power on to a select Channel such as a hospital welcome channel. If set to last, and physical power is removed, TV will power up to the lowest channel in current service level.

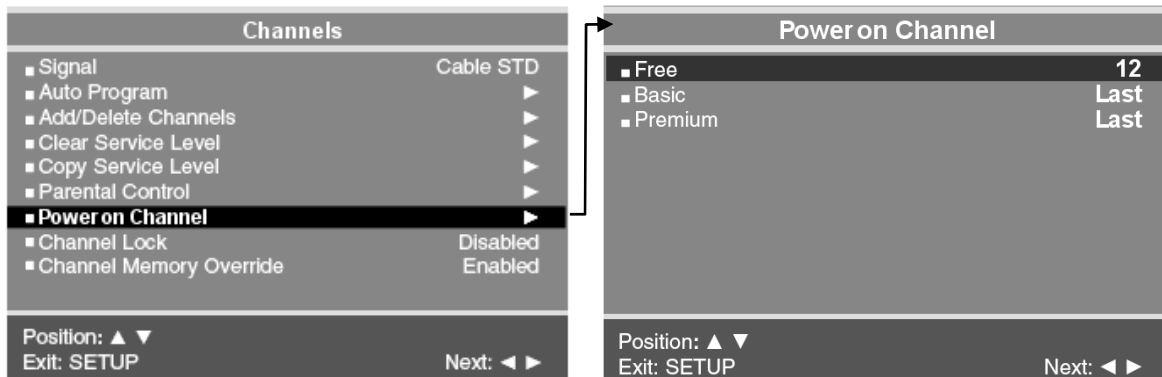

1. From the Channels menu, press the CH▲ / CH▼ buttons to select Power on Channel. Press VOL▶ button to activate.

2. In the Power on Channel Menu, press the CH▲ / CH▼ buttons to select the Service Level to adjust.
3. Press the VOL▲ / VOL▼ button to change the power on channel. NOTE: The channel must be programmed into the current service level. The “Last” entry causes the TV to power on from the Last channel viewed, or if physical power is interrupted and restored the TV will power on to the lowest channel in the current Service Level.
4. Press the SETUP button to exit.

Channel Lock

The Channel Lock feature locks the TV to the currently viewed channel and disables the channel up and channel down TV commands. Enable Channel Lock in waiting areas to prevent patients or visitors from changing the channel.

1. In the Channels menu, press the CH▲ / CH▼ buttons to select Channel Lock.
2. Press the VOL▲ / VOL▼ button to alternately enable or disable Channel Lock.
3. Press the SETUP button to exit.

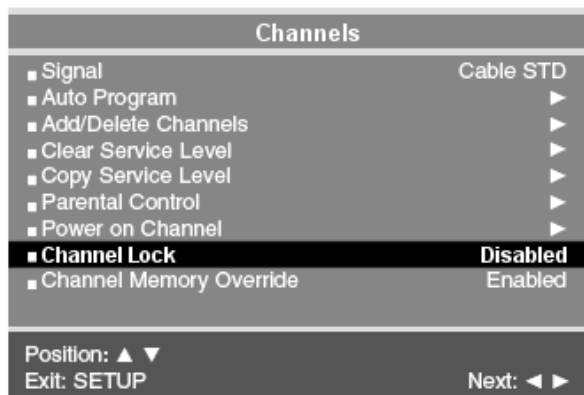

Channel Memory Override

Channel Memory Override allows a channel number to be entered from either a remote control or through the TV's keypad for viewing that is not currently programmed into the current Service Level. Channel Memory Override (Disabled) would prevent access to banned channels such as a Pediatric TV tuning directly to a Maternity channel.

1. In the Channels menu, press the CH▲ / CH▼ buttons to select Channel Memory Override.
2. Press the VOL▲ / VOL▼ button to alternately enable or disable Channel Memory Override.
 Disabled = Service Level Channels Only
 Enabled = Every Channel Available
3. Press the SETUP button to exit.

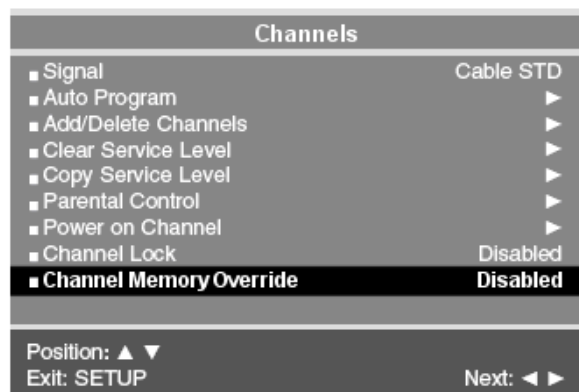

Features

The Features menu provides adjustable settings that customize the TV to your hospital.

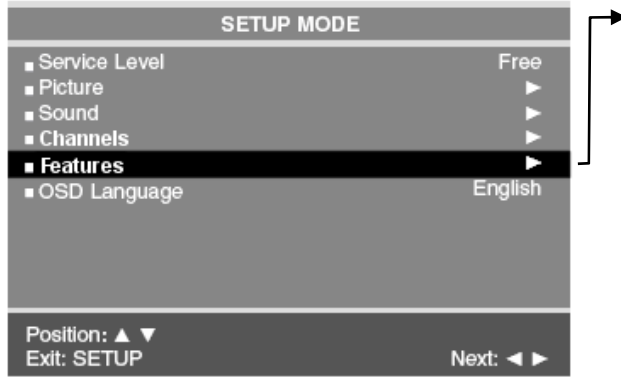

NEED NEW SCREEN SHOT

1. Press the SETUP button to display the SETUP MODE menu.
2. Press the CH▲ / CH▼ button and select Features.
3. Press VOL▲ / VOL▼ to select.

Power on Caption Mode

Power on Captions Mode memorizes the caption setting upon powering the TV off. With this feature set to Off, the TV will always power on with captions disabled. With this feature set to Last, the TV power on with the last used caption's setting.

1. Press the SETUP button.
2. Press the CH▲ / CH▼ button to select the Features menu.
3. Press the CH▲ / CH▼ button to select Power On Captions Mode.
4. Press the VOL▲ / VOL▼ button to select Last or Off.
5. Press the SETUP button to return to the preceding menu.

NEED NEW SCREEN SHOT

Auto Power On / Lock

The TV will turn on and stay on whenever electrical power is applied to the set. This feature is useful for controlling the TV from a wall switch or preventing the TV from being turned off via the front TV power button, IR remote, or pillow speaker.

1. In Features menu, press the CH▲ / CH▼ button to select Auto Power On / Lock. **NEED NEW SCREEN SHOT**
2. Press the VOL▲ / VOL▼ button to select Disabled or Enabled.
3. Press the SETUP button to return to the preceding menu.

Inactive Power Off (h:mm)

The TV will automatically power off after a specific period of viewer inactivity providing energy savings.

1. In Features menu, press the CH▲ / CH▼ button to select Inactive Power Off (h:mm). **NEED NEW SCREEN SHOT**
2. Press the VOL▲ / VOL▼ button to determine active time. Set to Disabled to turn off this feature.
3. Press the SETUP button to return to the preceding menu.

NOTE: Auto Power On/ Lock must be set to Disabled for this function to operate.

Caption Text Modes

Teletext can be displayed in addition to Captions. Teletext is not normally broadcast in the USA. Caption Text Modes should be set to Disabled for televisions operated in the USA.

1. In Features menu, press the CH▲ / CH▼ button to select Caption Text Modes.
2. Press the VOL▲ / VOL▼ button to select Disabled or Enabled.
3. Press the SETUP button to return to the preceding menu.

Caption Text Modes = Enabled, the caption mode is displayed as shown below.

Off → CC1 → CC2 → Text1 → Text2 → Off

Caption Text Modes = Disabled, the caption mode is displayed as shown below.

Off → CC1 → CC2 → Off

Features	
■ Power on Caption Mode	Last
■ Auto Power On / Lock	Disabled
■ Inactive Power Off (h:mm)	Disabled
■ Bed A/B	A
■ Captions Text Modes	Disabled
■ Digital Captions	▶
■ Digital Mode Time Setup	▶
■ Diagnostics	▶
■ Channel Up Power Off	Disabled
■ Power On ARC Mode	4:3
Position: ▲ ▼	
Exit: SETUP	Next: ◀ ▶

Digital Captions

Customization of Closed Captions on ATSC/QAM channels.

Features		Digital Captions	
■ Power on Caption Mode	Last	■ Font Size	Default
■ Auto Power On / Lock	Disabled	■ Font Style	Default
■ Inactive Power Off (h:mm)	Disabled	■ Foreground Color	Default
■ Bed A/B	A	■ Background Color	Default
■ Caption Text Modes	Disabled	■ Edge Color	Default
■ Digital Captions	▶	■ Foreground Opacity	Default
■ Digital Mode Time Setup	▶	■ Background Opacity	Default
■ Diagnostics	▶	■ Edge Style	Default
■ Channel Up Power Off	Disabled		
■ Power On ARC Mode	4:3		
Position: ▲ ▼		Position: ▲ ▼	
Exit: SETUP	Next: ◀ ▶	Exit: SETUP	Next: ◀ ▶

1. In Features menu, press the CH▲ / CH▼ button to select Digital Captions.
2. Press the VOL▲ / VOL▼ button to select.
3. Press the CH▲ / CH▼ button to select the desired Font attribute and adjust using the VOL▲ / VOL▼ button.
4. Press the SETUP button to return to the preceding menu.

Digital Mode Time Setup

The current time will be set automatically from a digital channel signal provided by a broadcasting TV station.



1. In Features menu, press the CH▲ / CH▼ button to select Digital Mode Time Setup.
2. Press the VOL▲ / VOL▼ button to select your viewing area time zone; Pacific, Alaska, Hawaii, Newfoundland, Atlantic, Eastern, Central, Mountain.
3. Press the CH▲ / CH▼ button to select Daylight Saving.
4. Press the VOL▲ / VOL▼ button to select Auto, On, Off depending on whether or not your viewing area observes Daylight Saving time.
5. Press the SETUP button to return to the preceding menu.

Diagnostics

This menu provides readouts of the TV's internal operation. The Diagnostics menu items are read-only and can not be changed.

NEED NEW SCREEN SHOT

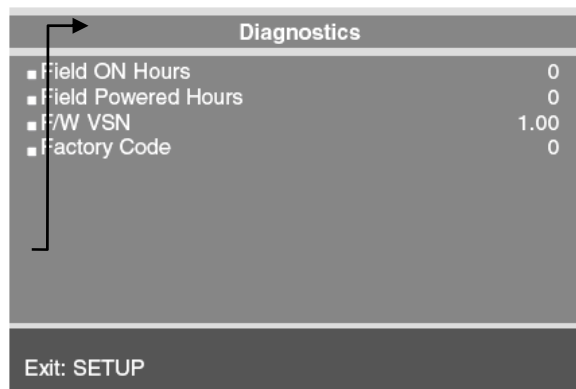

1. Features menu, press the CH▲ / CH▼ button to select Diagnostics.
2. Press the VOL▲ / VOL▼ button to select and view. NOTE: The Diagnostics items can not be highlight or changed. These values are read-only.

Field ON Hours:	Cumulative time TV is actually on.
Field Powered Hours:	Cumulative time TV is powered.
F/W VSN:	Firmware Version.
Factory Code:	Used for Factory Diagnostics.

Channel Up Power Off

This feature causes the TV to turn off once it reaches the highest numbered (last) channel and is usually used with single button style pillow speakers. When the feature is disabled, the TV will continue on to the lowest channel and not turn off.

1. In Features menu, press the CH▲ / CH▼ button to select Channel Up Power Off.
2. Press the VOL▲ / VOL▼ button to select Enabled or Disabled.
3. Press the SETUP button to return to the preceding menu.

NEED NEW SCREEN SHOT

Power On ARC Mode

The TV powers on with a set screen sized aspect ratio of 16:9, 4:3, Zoom, or Last selected ARC. (ARC = Aspect Ration Control)

1. In Features menu, press the CH▲ / CH▼ button to select Power On ARC Mode.
2. Press the VOL▲ / VOL▼ button to select 16:9, 4:3, Zoom, or Last select ARC.
3. Press the SETUP button to return to the preceding menu.

NEED NEW SCREEN SHOT

OSD Language

The language used in displaying the OSD (On Screen Display) such as the menu's can be set for English, French, or Spanish. NOTE: OSD Language does not affect Caption subtitling.

1. Press the SETUP button on the remote control.
2. Press the CH▲ / CH▼ button to select the OSD Language menu.
3. Press the ◀▶ button to select your desired language.



4. Press the SETUP button to exit the main menu.

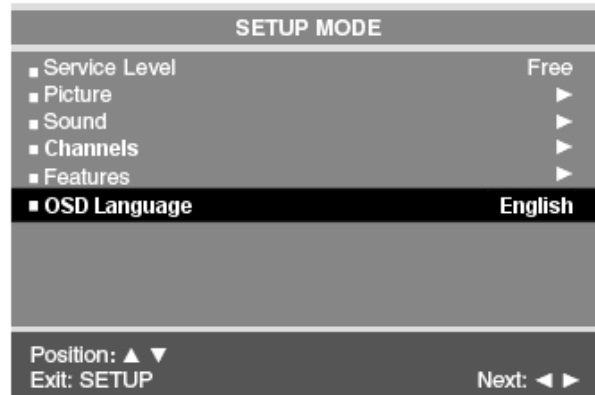

CLONING

Cloning allows quick programming of a TV from a USB memory stick (Thumb Drive). Clone operation involves first downloading setup information from a programmed host TV to a Thumb Drive and then uploading the setup information to another TV. Cloning can also be used to re-program a programmed TV.

Save Settings to USB

1. Create a directory titled "PDITDF" on a USB Thumb Drive.
2. Lift the arm's nose cover and locate the USB cable exiting the top of the TV's swivel.
3. Turn the TV on, and insert the USB Thumb Drive. A Cloning Main Menu will appear.
4. Press the CH▲ / CH▼ button to select Save Settings to TV. Press VOL▶ to display.

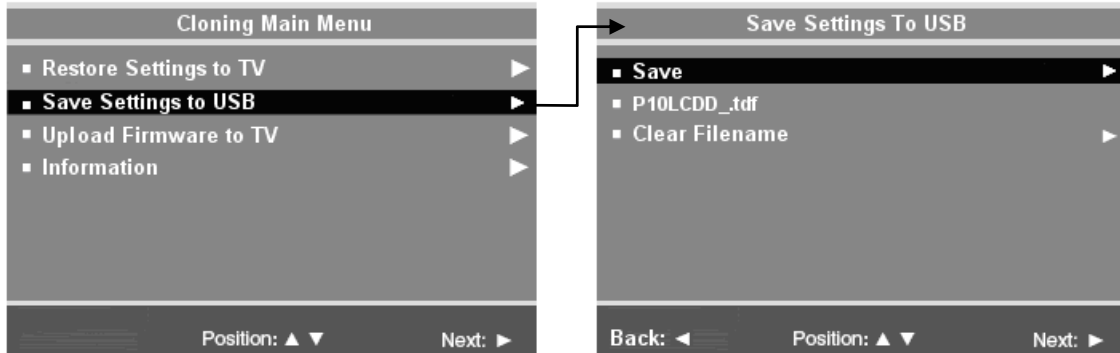

5. Select the file name displayed on the second line and rename if desired. Up to 8 characters may be used.
6. Select Save to download the TV's setup to the thumb drive. A progress screen will be displayed. A confirmation screen will indicate completion of the saved file. Press VOL◀ to return to the main Clone menu.
7. Remove the USB drive to return to normal TV operation. Close the Arm's Nose Cover and reattach.

Restore Setting to TV

1. Lift the arm's nose cover and locate the USB cable exiting the top of the TV's swivel.
2. Turn the TV on, and insert the USB Thumb Drive. A Cloning Main Menu will appear

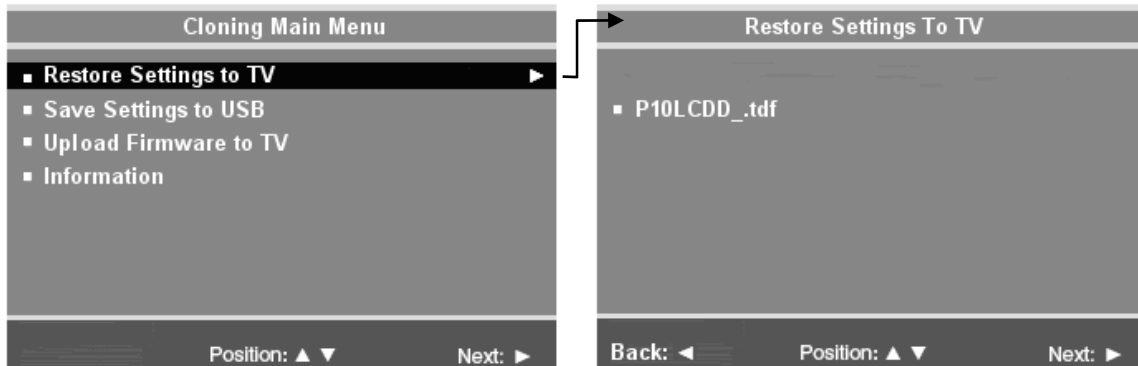

3. Press the CH▲ / CH▼ button to select Restore Settings to TV. Press VOL▶ to display a list of previously stored TV setups on the USB thumb drive.
4. Press the CH▲ / CH▼ button to select a TV's setup file. Press VOL▲ once.
5. A confirmation screen will appear. Press the CH▲ to restore the selected setup file or press / VOL▼ to exit without restoring. A progress screen will appear as the settings are restored.

6. Once complete, the TV will turn Off and then back On automatically.
7. Remove the USB thumb drive.
8. Verify correct programming of the TV.
9. Close the Arm's Nose Cover and fasten with provided screws.

FAQ – Frequently Asked Questions

Q. The TV displays a message saying, “No Channels Available, Please Contact a TV Representative” and then shuts off. How do I correct this problem?

A. The TV has been mistakenly set to a Service Level that is blank, one without any channels. Set the TV’s Service Level to one that is programmed with channels.

1. Turn the TV On.
2. Press the “SETUP” button on the remote control. The “SETUP MODE” screen will appear.
3. Use the “VOL▲” or “VOL▼” button to change the Service Level to one that is programmed. Usually “Free” is always programmed.
4. Press the “SETUP” button to exit and return to normal TV viewing.

HINT: Once you have restored TV service and verified the “Free” service level as programmed with channels, copy this service level to both the “Basic” and “Premium” levels as well. If an attendant mistakenly enables a different service level other than “Free”, the same channels will still be viewable and the message will not longer appear.

Q. Our hospital offers maternity and other educational services to select areas of the hospital. How do I program for these channels only?

A. The PERSONA 10 offers three distinct service levels: Free, Basic, and Premium. Program the maternity or educational channels into the Premium service level. Televisions placed into those locations that require maternity or educational services would simply have their service level set to “Premium”.

Q. Our hospital has a “Welcome Channel”. How do I program the TV to start on the “Welcome Channel” every time it is turned ON?

A. The PERSONA 10 offers a “Power On Channel” setting for each service level. In the “Channels” menu, set the “Power On Channel” menu item to the hospital Welcome channel number. See the section titled *Power On Channel* in this manual for additional details.

APPENDIX A – Installation on Other PDI-508C Arms

The suspension arm must be adjusted to the proper weight of the television in order to operate correctly. PDI arm model “PDI-508C-7” is factory adjusted for the proper weight. If this television is installed on a previously existing suspension arm, adjustment of the internal springs may be required.

The PDI-P10LCDD television must be installed on the arm before making this adjustment.

PROCEDURE:

EXISTING TELEVISION REMOVAL / LCD TELEVISION INSTALLATION: See page 7 & 8.

1. Remove the safety brake pin from the nose of the existing arm and install into the parking brake hole at the base of the arm.
2. Remove the existing television from the arm. The swivel retainer plate and nut will not be needed for the new television.
3. Remove and discard the ¼-20 x ¾” Socket Head Cap screw swivel retainer bolt from the bottom of the nose.
4. Install the new LCD television onto the nose by following the steps in the “Installing TV on Suspension Arm” section of this document.

ARM ADJUSTMENT:

Please refer to the “Arm Adjustment Illustration” on the following page.

1. Remove the elbow access cover.
2. Loosen each of four Brake Tension Screws ½ turn only. Brake Tension screws are located on both sides of the base and nose. See “Brake Tension Screw Detail” illustration.
3. Locate each internal spring’s 7/16” Hex head adjustment bolt.
4. *While maintaining a firm grip on the bottom of the television*, carefully remove the safety brake pin from the parking brake hole at the base of the arm.
5. Adjust the Front Internal spring bolt. **WARNING:** DO NOT loosen more than 10 complete turns. Any more turns beyond 10 will result in disconnecting the spring and *cause the arm to fall*, rendering the arm useless and possibly causing personal injury.
6. Adjust the Rear Internal spring bolt. **WARNING:** DO NOT loosen more than 10 complete turns. Any more turns beyond 10 will result in disconnecting the spring and *cause the arm to fall*, rendering the arm useless and possibly causing personal injury.
7. After reaching the desired adjustment, re-tighten all four Brake Tension Screws.
8. Replace the elbow cover.

NOTE: The internal springs are adjusted by loosening (counter-clockwise) to decrease the arm’s lifting force, or tightened (clockwise) to increase the arm’s lifting force. As adjustments are made, move the TV to different positions. The adjustment is correct when the TV can be positioned without any creep age either up or down.

If you need assistance during this procedure, contact PDI’s Service Department at 937-743-6010.

Appendix A - Continued

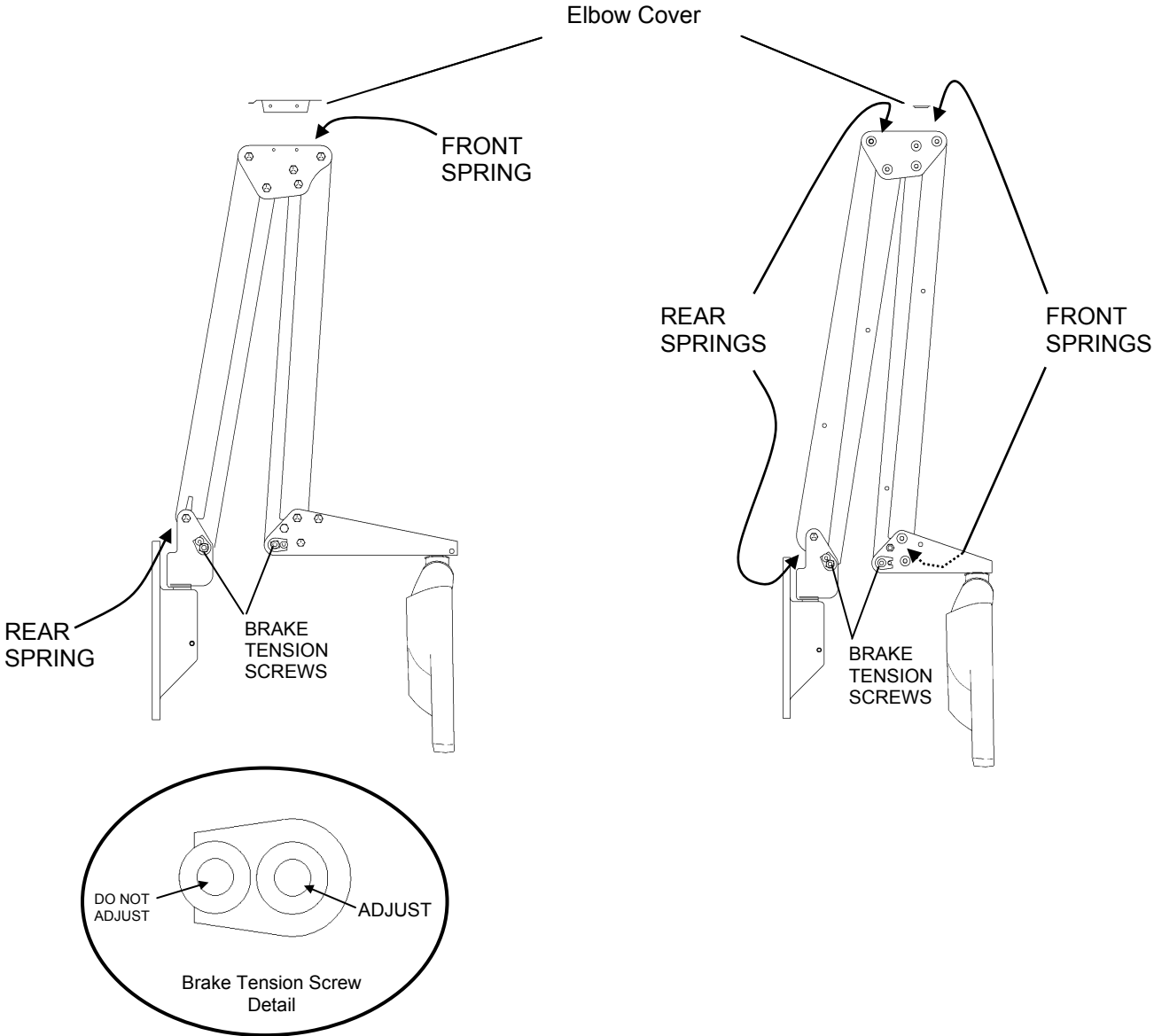

Arm Adjustment Illustration

Limited Warranty

NOTE: Opening the TV set, or attempting a repair by non-PDI personnel will void the Warranty!

PDI Communication Systems Inc., ("PDI") warrants, to the original purchaser only, that this television will be free from defects in materials and workmanship, under normal use, for 2 years from the date of original purchase. This warranty does not cover any other equipment that may have been included with PDI's shipment of this product.

After receipt of written notice of a defect or malfunction occurring during the warranty period, PDI will repair or replace goods returned to its Springboro, Ohio location, at its discretion, free of charge to the original purchaser, the whole or any component part of any product manufactured by PDI and found by PDI to be defective.

As a condition to obtaining warranty service, written notification must be received by PDI within at least ten (10) days after defect is first observed. Repair of said product requires it to be shipped to the PDI factory in Springboro, Ohio. All shipments shall be F.O.B. Springboro, Ohio, and all shipping and freight charges to PDI's factory shall be paid by the customer.

This warranty shall not apply to any PDI products subjected to improper use, negligence or accident; nor to tampering, alterations, or repairs by others, without PDI's specific prior written authorization. For information regarding authorized servicing and all other information pertaining to this warranty, please contact PDI COMMUNICATION SYSTEMS at 40 Greenwood Lane, Springboro, Ohio 45066 or phone 937-743-6010.

This warranty gives specific legal rights and you may also have other rights which vary from state to state.

PDI's liability under this warranty is limited to repair or replacement of defective products and parts as provided above. PDI shall not be liable for incidental or consequential damages.*

The warranty contained herein is in lieu of all other expressed or implied warranties, including any implied warranty of merchantability or fitness for any particular purpose. PDI neither assumes nor authorizes any person to assume, on its behalf, any other obligation or liability.

*Some states do not allow the exclusion of limitation of incidental or consequential damages or a disclaimer of warranties implied by law, so the above limitation or exclusion may not apply.

The information and technical data in this manual is believed accurate, but is not warranted and is subject to change without notice or obligation.

"PDI" and "Better Solutions Are Within Reach" are registered trademarks of PDI Communication Systems, Inc.

Copyright © 2004-2008 by PDI Communication Systems, Inc.
All rights reserved.