

PDI-Z13TVE-ARM(-WR)

SERVICE MANUAL

COLOR TELEVISION RECEIVER

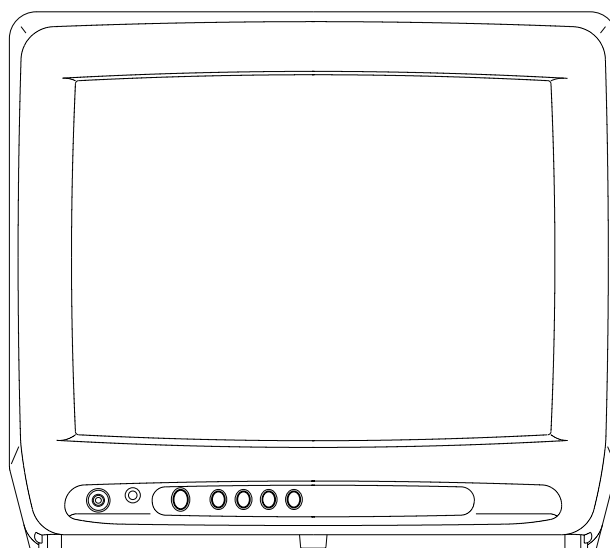

**ORIGINAL
MFR'S VERSION C**

SERVICING NOTICES ON CHECKING

1. KEEP THE NOTICES

As for the places which need special attentions, they are indicated with the labels or seals on the cabinet, chassis and parts. Make sure to keep the indications and notices in the operation manual.

2. AVOID AN ELECTRIC SHOCK

There is a high voltage part inside. Avoid an electric shock while the electric current is flowing.

3. USE THE DESIGNATED PARTS

The parts in this equipment have the specific characters of incombustibility and withstand voltage for safety. Therefore, the part which is replaced should be used the part which has the same character.

Especially as to the important parts for safety which is indicated in the circuit diagram or the table of parts as a \triangle mark, the designated parts must be used.

4. PUT PARTS AND WIRES IN THE ORIGINAL POSITION AFTER ASSEMBLING OR WIRING

There are parts which use the insulation material such as a tube or tape for safety, or which are assembled in the condition that these do not contact with the printed board. The inside wiring is designed not to get closer to the pyrogenic parts and high voltage parts. Therefore, put these parts in the original positions.

5. TAKE CARE TO DEAL WITH THE CATHODE-RAY TUBE

In the condition that an explosion-proof cathode-ray tube is set in this equipment, safety is secured against implosion. However, when removing it or serving from backward, it is dangerous to give a shock. Take enough care to deal with it.

6. AVOID AN X-RAY

Safety is secured against an X-ray by considering about the cathode-ray tube and the high voltage peripheral circuit, etc.

Therefore, when repairing the high voltage peripheral circuit, use the designated parts and make sure not modify the circuit.

Repairing except indicates causes rising of high voltage, and it emits an X-ray from the cathode-ray tube.

7. PERFORM A SAFETY CHECK AFTER SERVICING

Confirm that the screws, parts and wiring which were removed in order to service are put in the original positions, or whether there are the portions which are deteriorated around the serviced places serviced or not. Check the insulation between the antenna terminal or external metal and the AC cord plug blades. And be sure the safety of that.

(INSULATION CHECK PROCEDURE)

1. Unplug the plug from the AC outlet.
2. Remove the antenna terminal on TV and turn on the TV.
3. Insulation resistance between the cord plug terminals and the external exposure metal [Note 2] should be more than 1M ohm by using the 500V insulation resistance meter [Note 1].
4. If the insulation resistance is less than 1M ohm, the inspection repair should be required.

[Note 1]

If you have not the 500V insulation resistance meter, use a Tester.

[Note 2]

External exposure metal: Antenna terminal
Earphone jack

HOW TO ORDER PARTS

Please include the following informations when you order parts. (Particularly the VERSION LETTER.)

1. MODEL NUMBER and VERSION LETTER

The MODEL NUMBER can be found on the back of each product and the VERSION LETTER can be found at the end of the SERIAL NUMBER.

2. PART NO. and DESCRIPTION

You can find it in your SERVICE MANUAL.

IMPORTANT

Inferior silicon grease can damage IC's and transistors.

When replacing an IC's or transistors, use only specified silicon grease (YG6260M).

Remove all old silicon before applying new silicon.

CONTENTS

SERVICING NOTICES ON CHECKING	A1-1
HOW TO ORDER PARTS	A1-1
IMPORTANT	A1-1
CONTENTS	A2-1
GENERAL SPECIFICATIONS	A3-1~A3-4
DISASSEMBLY INSTRUCTIONS	
1. REMOVAL OF ANODE CAP	B-1
2. REMOVAL AND INSTALLATION OF FALT PACKAGE IC	B2-1, B2-2
SERVICE MODE LIST	C-1
CONFIRMATION OF HOURS USED	C-1
WHAN REPLACING EEPROM (MEMORY) IC	C-1
ELECTRICAL ADJUSTMENTS	D-1~D-4
BLOCK DIAGRAM	E-1, E-2
PRINTED CIRCUIT BOARDS	
MAIN/CRT	F-1~F-4
SCHEMATIC DIAGRAMS	
MICON/TUNER	G-1, G-2
CHROMA	G-3, G-4
TV POWER	G-5, G-6
DEFLECTION/CRT	G-7, G-8
SOUND/AV	G-9, G-10
WAVEFORMS	H-1, H-2
MECHANICAL EXPLODED VIEW	I-1
MECHANICAL REPLACEMENT PARTS LIST	J1-1
ELECTRICAL REPLACEMENT PARTS LIST	J2-1~J2-3
SERIAL NUMBER CODE	K-1

GENERAL SPECIFICATIONS

G-1	TV System	CRT	CRT Size / Visual Size	13 inch / 335.4mmV	
			CRT Type	Normal	
			Deflection	90 degree	
			Magnetic Field	BV/BH	
				+0.45G/0.18G	
			Color System	NTSC	
			Speaker	1Speaker	
				Position	Bottom
				Size	3 Inch
				Impedance	8 ohm
G-2	Tuning System	Broadcasting System		US System M	
		Tuner and Receive CH	System	1Tuner	
			Destination	Others	
			Tuning System	F-Synth	
			Input Impedance	VHF/UHF 75 ohm	
				CH Coverage	2 - 69, 4A, A-5 - A-1, A - I, J - W, W+1 - W+84
			Intermediate Frequency	Picture(FP)	45 75MHz
				Sound(FS)	41 25MHz
				FP-FS	4.50MHz
			Preset CH		No
G-3	Power	Power Source	AC	120V AC 60Hz	
			DC		
		Power Consumption		at AC	
			Stand by (at AC)		54 W at AC 120 V 60 Hz
G-4	Regulation		Per Year	5 W at AC 120 V 60 Hz	
				-- kWh/Year	
		Protector	Power Fuse	Yes	
G-5	Temperature		Safety	UL	
			Radiation	FCC	
			X-Radiation	DHHS	
G-6	Operating Humidity		Operation	+5°C ~ +40°C	
			Storage	-20°C ~ +60°C	
G-7	On Screen Display	Menu		Yes	
			Menu Type	Character	
			Picture	Yes	
				Contrast	Yes
				Brightness	Yes
				Color	Yes
				Tint	Yes
				Sharpness	Yes
			Audio		No
				Bass	No
				Treble	No
				Balance	No
				BBE On/Off	No
				Stable Sound On/Off	No
			CH Set Up		Yes
				TV/CATV	Yes
				Auto CH Memory	Yes
				Add/ Delete	Yes
			Language		Yes
			V-chip		Yes
				CH Label	No
				Favorite CH	No
				Color Stream DVD/DTV	No
			Control Level		Yes
				Sound	Yes
				Brightness	Yes
				Contrast	Yes
				Color	Yes
				Tint (NTSC Only)	Yes
				Sharpness	Yes
				Tuning	No
				Bass	No
		Treble	No		
		Balance	No		
		Back Light	No		
		Stereo,Audio Output,SAP	No		
	Video		Yes		
	Color Stream		No		

GENERAL SPECIFICATIONS

		Channel(TV/Cable)	Yes	
		CH Label		No
		Sleep Timer	Yes	
		Sound Mute	Yes	
		V-chip Rating	Yes	
G-8	OSD Language	OSD Language Setting	English	French Spanish
			English	
G-9	Clock and Timer	Sleep Timer	Max Time	120 Min
			Step	10 Min
		On/Off Timer	Program(On Tim / Off Tim)	No
		Wake Up Timer		No
		Timer Back-up (at Power Off Mode)	more than	-- Min Sec
G-10	Remote Control	Unit	RC-DW	
		Glow in Dark Remocon	No	
		Format	NEC	
		Custom Code	86-05 h	
		Power Source	Voltage(D.C)	3V
			UM size x pcs	UM-4 x 2 pcs
		Total Keys	27 Keys	
		Keys	Power	Yes
			1	Yes
			2	Yes
			3	Yes
			4	Yes
			5	Yes
			6	Yes
			7	Yes
			8	Yes
			9	Yes
			0	Yes
			100	No
			CH Up	Yes
			CH Down	Yes
			Volume Up	Yes
			Volume Down	Yes
			TV/Caption/Text	Yes
			CH1/CH2	Yes
			TV/Video(TV/AV)	Yes
			CH RTN/CH ENT(Quick View)	Yes
			Sleep	Yes
			RE Call(Call)	Yes
			Reset	Yes
			Menu	Yes
			Enter	Yes
			Mute	Yes
			Exit	No
			MTS(Audio Select)	No
			Set +	Yes
			Set -	Yes
		Multi Brand Keys	CH Up(VCR)	No
			CH Down(VCR)	No
			Pause/Still	No
			TV/VCR(VCR)	No
			Code	No
			FF	No
			Rew	No
			Rec	No
			Play	No
			Stop	No
			TV	No
			VCR	No
			Cable	No
G-11	Features	Auto Degauss	Yes	
		Auto Shut Off	Yes	
		Canal+	No	
		CATV	Yes	
		Anti-theft	No	
		Rental	No	
		Memory>Last CH)	Yes	
		Memory>Last Volume)	Yes	
		V-Chip	Yes	
		Type	USA,ORION Type	
		BBE	No	
		Auto Search	No	
		CH Allocation	No	

GENERAL SPECIFICATIONS

		SAP			No	
		Channel Lock			No	
		Just Clock Function			No	
		Game Position			No	
		CH Label			No	
		VM Circuit			No	
		Full OSD			No	
		Premiere			No	
		Comb Filter			No	
				Lines		
		Auto CH Memory		Yes		
		Hotel Lock			No	
		Closed Caption		Yes		
		Stable Sound			No	
		Energy Star			No	
		Favorite CH			No	
G-12	Accessories	Owner's Manual	Language	English	Spanish	
			w/Guarantee Card		No	
		Remote Control Unit		Yes		
		Rod Antenna		Yes		
			Poles	1 Pole		
			Terminal	F type		
		Loop Antenna		-		No
			Terminal			
		U/V Mixer				No
		DC Car Cord (Center+)				No
		Guarantee Card		Yes		
		Warning Sheet				No
		Circuit Diagram				No
		Antenna Change Plug				No
		Service Facility List				No
		Important Safeguard				No
		Dew/AHC Caution Sheet				No
		AC Plug Adapter				No
		Quick Set-up Sheet				No
		Battery				No
		UM size x pcs				
		OEM Brand		No		
		AC Cord		No		
		AV Cord (2Pin-1Pin)		No		
		Registration Card	Yes			
		PTB Sheet		No		
		300 ohm to 75 ohm Antenna Adapter		No		
G-13	Interface	Switch	Front	Power	Yes	
				System Select		No
				Main Power SW		No
				Sub Power		No
				Channel Up/Reset	Yes	
				Channel Down/Enter	Yes	
				Volume Up/Set Up	Yes	
				Volume Down/Set Down	Yes	
				MENU=Volume Up+Volume Down	Yes	
			Rear	AC/DC		No
				TV/CATV Selector		No
				Degauss		No
				Main Power SW		No
			Indicator	Power		No
				Stand-by		No
				On Timer		No
			Terminals	Front	Video Input	RCA
					Audio Input	RCA x 1
					Other Terminal	Ear Phone
				Rear	Video Input(Rear1)	No
					Video Input(Rear2)	No
					Audio Input(Rear1)	No
					Audio Input(Rear2)	No
					Video Output	No
					Audio Output	No
					Euro Scart	No
					Color Stream	No
			Diversity	No		
			Ext Speaker	No		
			DC Jack 12V(Center +)	No		
			VHF/UHF Antenna Input	F Type		
			AC Outlet	No		
G-14	Set Size		Approx. W x D x H (mm)	362 x 360 x 320.5		

GENERAL SPECIFICATIONS

G-15	Weight	Net (Approx)	9.5 kg	(20.9 lbs)
		Gross (Approx.)	11.0kg	(24.4lbs)
G-16	Carton	Master Carton	No	
		Content	Sets	
		Material	/--	
		Dimensions W x D x H(mm)	-- x -- x --	
		Description of Origin	No	
		Gift Box	Yes	
		Material	Double/White	
		Dimensions W x D x H(mm)	440 x 408 x 380	
		Design	As per Buyer's	
		Description of Origin	Yes	
		Drop Test	Natural Dropping At 1 Corner / 3 Edges / 6 Surfaces	
		Height (cm)	62	
		Container Stuffing	866 Sets/40' container	
G-17	Cabinet Material	Cabinet Front	PS 94V0	DECABROM
		Cabinet Rear	PS 94V0	DECABROM

DISASSEMBLY INSTRUCTIONS

1. REMOVAL OF ANODE CAP

Read the following **NOTED** items before starting work.

- * After turning the power off there might still be a potential voltage that is very dangerous. When removing the Anode Cap, make sure to discharge the Anode Cap's potential voltage.
- * Do not use pliers to loosen or tighten the Anode Cap terminal, this may cause the spring to be damaged.

REMOVAL

1. Follow the steps as follows to discharge the Anode Cap. (Refer to Fig. 1-1.)
Connect one end of an Alligator Clip to the metal part of a flat-blade screwdriver and the other end to ground. While holding the plastic part of the insulated screwdriver, touch the support of the Anode with the tip of the screwdriver.
A cracking noise will be heard as the voltage is discharged.

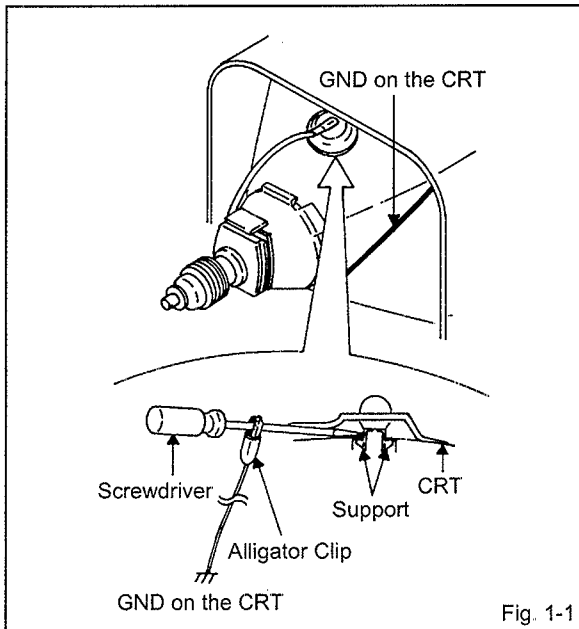

Fig. 1-1

2. Flip up the sides of the Rubber Cap in the direction of the arrow and remove one side of the support. (Refer to Fig. 1-2.)

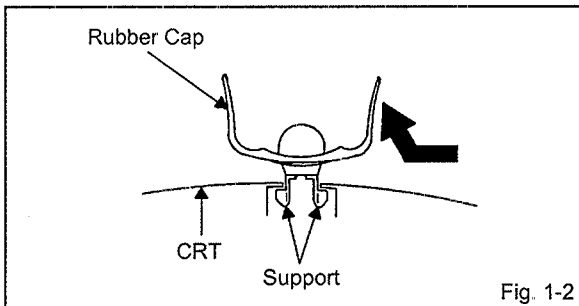

Fig. 1-2

3. After one side is removed, pull in the opposite direction to remove the other.

NOTE

Take care not to damage the Rubber Cap.

INSTALLATION

1. Clean the spot where the cap was located with a small amount of alcohol. (Refer to Fig. 1-3.)

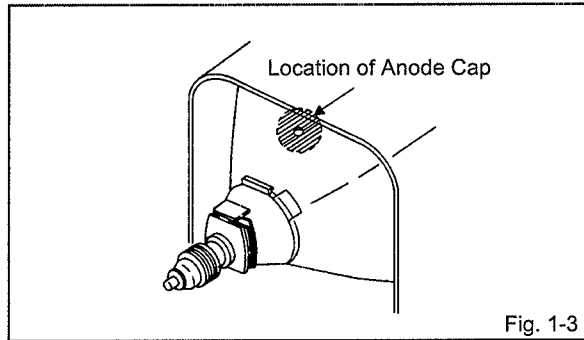

Fig. 1-3

NOTE

Confirm that there is no dirt, dust, etc. at the spot where the cap was located.

2. Arrange the wire of the Anode Cap and make sure the wire is not twisted.
3. Turn over the Rubber Cap. (Refer to Fig. 1-4.)

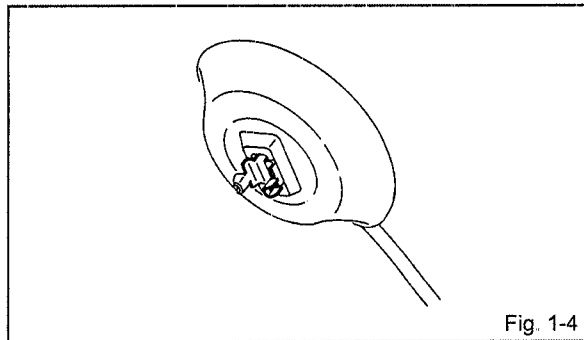

Fig. 1-4

4. Insert one end of the Anode Support into the anode button, then the other as shown in Fig. 1-5.

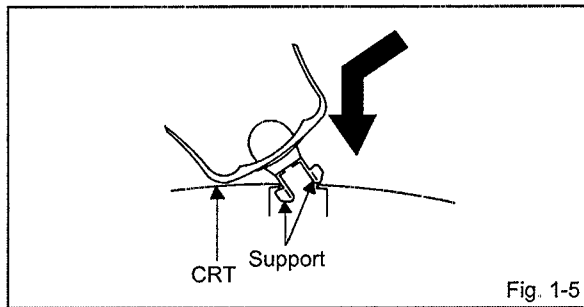

Fig. 1-5

5. Confirm that the Support is securely connected.
6. Put on the Rubber Cap without moving any parts.

DISASSEMBLY INSTRUCTIONS

2. REMOVAL AND INSTALLATION OF FLAT PACKAGE IC

REMOVAL

1. Put the Masking Tape (cotton tape) around the Flat Package IC to protect other parts from any damage. (Refer to Fig. 2-1.)

NOTE

Masking is carried out on all the parts located within 10 mm distance from IC leads.

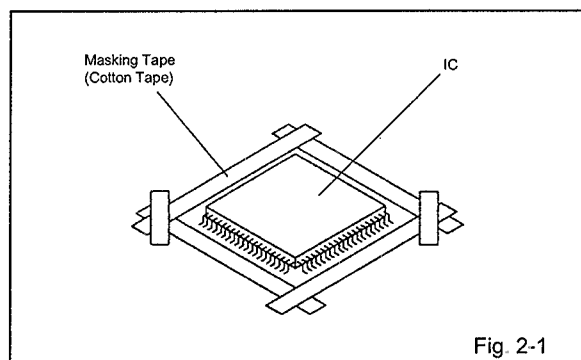

2. Heat the IC leads using a blower type IC desoldering machine. (Refer to Fig. 2-2.)

NOTE

Do not add the rotating and the back and forth directions force on the IC, until IC can move back and forth easily after desoldering the IC leads completely.

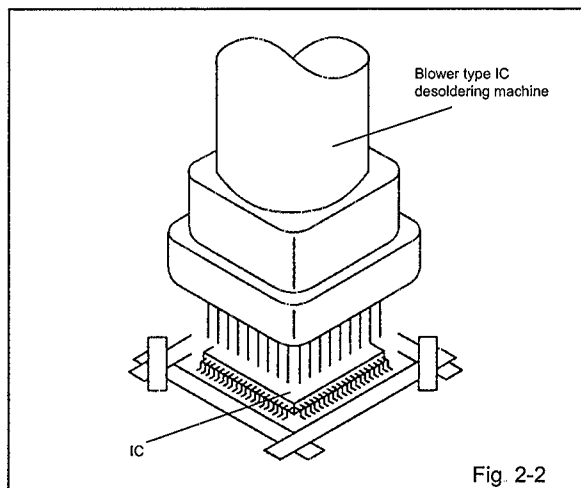

3. When IC starts moving back and forth easily after desoldering completely, pickup the corner of the IC using a tweezers and remove the IC by moving with the IC desoldering machine. (Refer to Fig. 2-3.)

NOTE

Some ICs on the PCB are affixed with glue, so be careful not to break or damage the foil of each IC leads or solder lands under the IC when removing it.

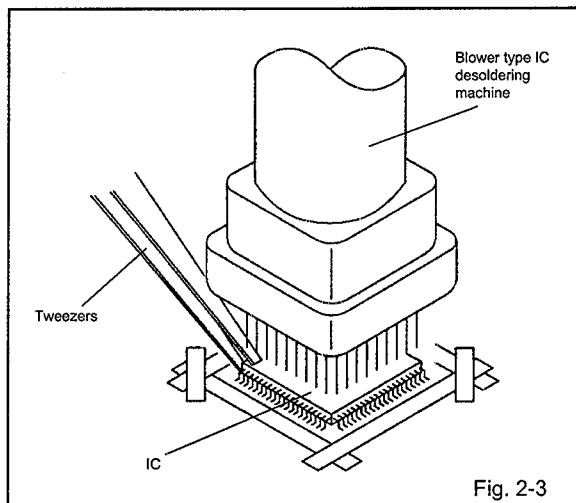

4. Peel off the Masking Tape.
5. Absorb the solder left on the pattern using the Braided Shield Wire. (Refer to Fig. 2-4.)

NOTE

Do not move the Braided Shield Wire in the vertical direction towards the IC pattern.

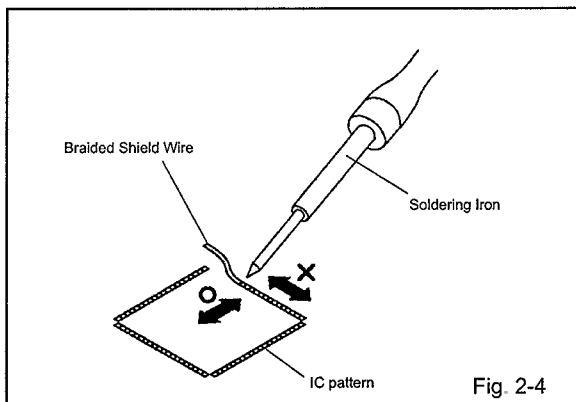

DISASSEMBLY INSTRUCTIONS

INSTALLATION

1. Take care of the polarity of new IC and then install the new IC fitting on the printed circuit pattern. Then solder each lead on the diagonal positions of IC temporarily. (Refer to Fig. 2-5.)

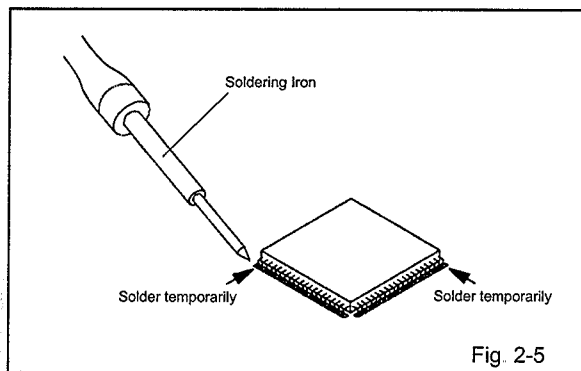

2. Supply the solder from the upper position of IC leads sliding to the lower position of the IC leads. (Refer to Fig. 2-6.)

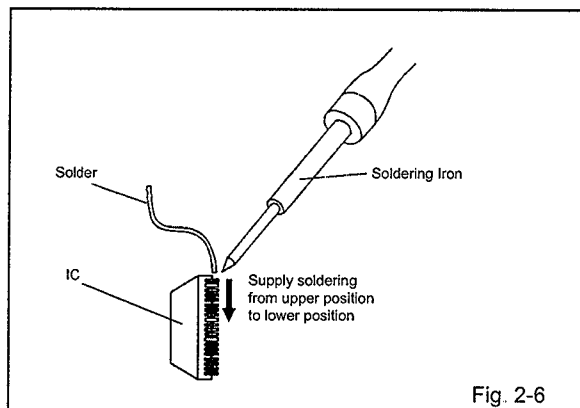

3. Absorb the solder left on the lead using the Braided Shield Wire. (Refer to Fig. 2-7.)

NOTE

Do not absorb the solder to excess.

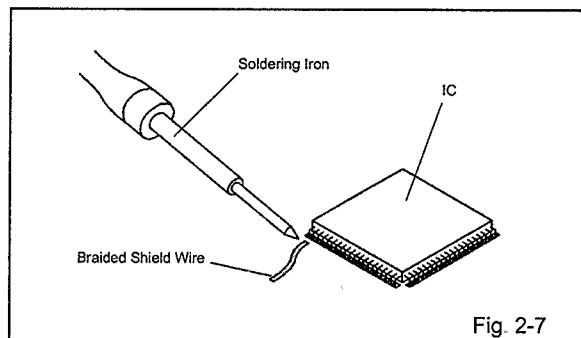

4. When bridge-soldering between terminals and/or the soldering amount are not enough, resolder using a Thin-tip Soldering Iron. (Refer to Fig. 2-8.)

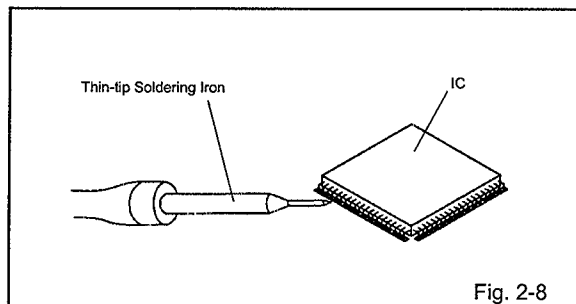

5. Finally, confirm the soldering status on four sides of the IC using a magnifying glass. Confirm that no abnormality is found on the soldering position and installation position of the parts around the IC. If some abnormality is found, correct by resoldering.

NOTE

When the IC leads are bent during soldering and/or repairing, do not repair the bending of leads. If the bending of leads are repaired, the pattern may be damaged. So, be always sure to replace the IC in this case.

SERVICE MODE LIST

This unit provided with the following SERVICE MODES so you can repair, examine and adjust easily. To enter the Service Mode, press both set key and remote control key for more than 1 second.

Set Key	Remocon Key	Operations
VOL. (-) MIN	0	Releasing of V-CHIP PASSWORD.
VOL. (-) MIN	1	Initialization of the factory. NOTE: Do not use this for the normal servicing. If you set a factory initialization, the memories are reser such as the clock setting, the cheannel setting, the POWER ON total hours, and PLAY/REC total hours.
VOL. (-) MIN	6	POWER ON total hours is displayed on the screen. Refer to the "CONFIRMATION OF HOURS USED". Can be checked of the INITIAL DATA of MEMORY IC. Refer to the "WHEN REPLACING EEPROM (MEMORY) IC".
VOL. (-) MIN	8	Writing of EEPROM initial data. NOTE: Do not use this for the normal servicing.
VOL. (-) MIN	9	Display of the Adjustment MENU on the screen. Refer to the "ELECTRICAL ADJUSTMENT" (On-Screen Display Adjustment).

CONFIRMATION OF HOURS USED

POWER ON total hours can be checked on the screen. Total hours are displayed in 16 system of notation.

1. Set the VOLUME to minimum.
2. Press both VOL. DOWN button on the set and Channel button (6) on the remote control for more than 1 second.
3. After the confirmation of using hours, turn off the power.

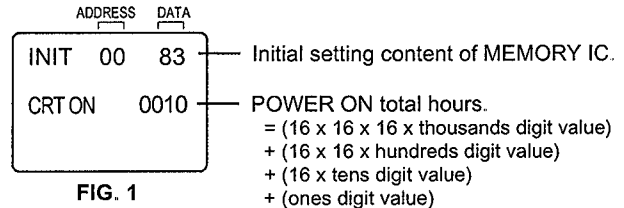

FIG. 1

WHEN REPLACING EEPROM (MEMORY) IC

If a service repair is undertaken where it has been required to change the MEMORY IC, the following steps should be taken to ensure correct data settings while making reference to TABLE 1.

INI	+0	+1	+2	+3	+4	+5	+6	+7	+8	+9	+A	+B	+C	+D	+E	+F
00	08	20	98	02	09	B3	24	19	01	00	44	05	00	D5	FF	A5

Table 1

1. Enter DATA SET mode by setting VOLUME to minimum.
2. Press both VOL. DOWN button on the set and Channel button (6) on the remote control for more than 1 second. ADDRESS and DATA should appear as FIG 1.
3. ADDRESS is now selected and should "blink". Using the SET + or - keys on the remote, step through the ADDRESS until required ADDRESS to be changed is reached.
4. Press ENTER to select DATA. When DATA is selected, it will "blink".
5. Again, step through the DATA using SET + or - until required DATA value has been selected.
6. Pressing ENTER will take you back to ADDRESS for further selection if necessary.
7. Repeat steps 3 to 6 until all data has been checked.
8. When satisfied correct DATA has been entered, turn POWER off (return to STANDBY MODE) to finish DATA input. The unit will now have the correct DATA for the new MEMORY IC.

ELECTRICAL ADJUSTMENTS

1. BEFORE MAKING ELECTRICAL ADJUSTMENTS

Read and perform these adjustments when repairing the circuits or replacing electrical parts or PCB assemblies.

CAUTION

- Use an isolation transformer when performing any service on this chassis.
- Before removing the anode cap, discharge electricity because it contains high voltage.
- When removing a PCB or related component, after unfastening or changing a wire, be sure to put the wire back in its original position.
- Inferior silicon grease can damage IC's and transistors. When
- When you exchange IC and Transistor for a heat sink, apply the silicon grease (**YG6260M**) on the contact section of the heat sink. Before applying new silicon grease, remove all the old silicon grease. (Old grease may cause damages to the IC and Transistor.)

Prepare the following measurement tools for electrical adjustments.

1. Synchro Scope
2. Digital Voltmeter

On-Screen Display Adjustment

1. In the condition of NO indication on the screen. Press the VOL. DOWN button on the set and the Channel button (**9**) on the remote control for more than 1 second to appear the adjustment mode on the screen as shown in Fig. 1-1.

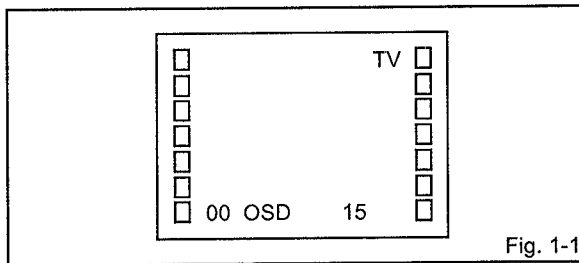

Fig. 1-1

2. Use the Channel UP/DOWN button or Channel button (**0-9**) on the remote control to select the options shown in Fig. 1-2.
3. Press the MENU button on the remote control to end the adjustments.

NO.	FUNCTION	NO.	FUNCTION
00	OSD H	16	CONTRAST CENT
01	CUT OFF	17	CONTRAST MAX
02	RF DELAY	18	CONTRAST MIN
03	VIF VCO	19	COLOR CENT
04	H.VCO	20	COLOR MAX
05	H.PHASE	21	COLOR MIN
06	V.SIZE	22	TINT
07	V.SHIFT	23	SHARPNESS
08	R.DRIVE	24	FM LEVEL
09	B.DRIVE	25	LEVEL
10	R.BIAS	26	SEPARATION 1
11	G.BIAS	27	SEPARATION 2
12	B.BIAS	28	TEST MONO
13	BRIGHT CENT	29	TEST STEREO
14	BRIGHT MAX	30	X-RAY TEST
15	BRIGHT MIN		

Fig. 1-2

2. BASIC ADJUSTMENTS

2-1: RF AGC DELAY

1. Place the set with Aging Test for more than 15 minutes.
2. Receive an 63dB monoscope pattern.
3. Connect the digital voltmeter to **W043**.
4. Activate the adjustment mode display of Fig. 1-1 and press the channel button (**02**) on the remote control to select "RF.AGC".
5. Press the VOL. UP/DOWN button on the remote control until the digital voltmeter is $2.50 \pm 0.05V$.

2-2: CUT OFF

1. Adjust the unit to the following settings.
R.DRIVE=10, B.DRIVE=10, R.BIAS=64, G.BIAS=64,
B.BIAS=64, BRIGHTNESS=110, CONTRAST=35.
2. Place the set with Aging Test for more than 15 minutes.
3. Activate the adjustment mode display of Fig. 1-1 and press the channel button (**01**) on the remote control to select "CUT OFF".
4. Adjust the **Screen Volume** until a dim raster is obtained.

2-3: FOCUS

1. Receive the monoscope pattern.
2. Turn the Focus Volume fully counterclockwise once.
3. Adjust the **Focus Volume** until picture is distinct.

2-4: WHITE BALANCE

NOTE: Adjust after performing CUT OFF adjustment.

1. Place the set with Aging Test for more than 10 minutes.
2. Receive the white 100% signal from the Pattern Generator.
3. Using the adjustment control, set the brightness and contrast to normal position.
4. Activate the adjustment mode display of Fig. 1-1 and press the channel button (**10**) on the remote control to select "R.BIAS".
5. Using the VOL. UP/DOWN button on the remote control, adjust the R.BIAS.
6. Press the CH. UP/DOWN button on the remote control to select the "R.DRIVE", "B.DRIVE", "G.BIAS" or "B.BIAS".
7. Using the VOL. UP/DOWN button on the remote control, adjust the R.DRIVE, B.DRIVE, G.BIAS or B.BIAS.
8. Perform the above adjustments 6 and 7 until the white color is looked like a white.

ELECTRICAL ADJUSTMENTS

2-5: SUB TINT/SUB COLOR

1. Receive the color bar pattern.
2. Connect the oscilloscope to TP023.
3. Activate the adjustment mode display of Fig. 1-1 and press the channel button (22) on the remote control to select "TINT".
4. Press the VOL. UP/DOWN button on the remote control until the section "A" becomes as straight line (Refer to Fig. 2-1)
5. Connect the oscilloscope to TP022.
6. Activate the adjustment mode display of Fig. 1-1 and press the channel button (19) on the remote control to select "COL.CENT".
7. Press the VOL. UP/DOWN button on the remote control until the red color level is adjusted to 100% of the white level. (Refer to Fig. 2-2)
8. Receive the color bar pattern. (Audio Video Input)
9. Press the TV/AV button on the remote control to set to the AV mode. Then perform the above adjustments 2--7

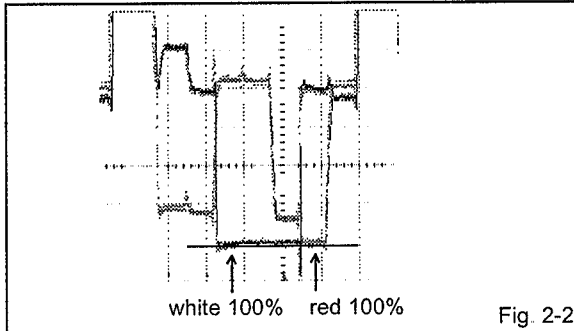
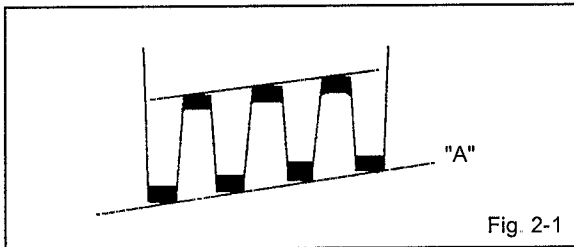

2-6: HORIZONTAL PHASE

1. Receive the center cross signal from the Pattern Generator.
2. Activate the adjustment mode display of Fig. 1-1 and press the channel button (05) on the remote control to select "H.PHAS".
3. Press the VOL. UP/DOWN button on the remote control until the SHIFT quantity of the OVER SCAN on right and left becomes minimum.

2-7: VERTICAL SIZE

NOTE: Adjust after performing adjustments in section 2-6

1. Receive the crosshatch signal from the Pattern Generator.
2. Activate the adjustment mode display of Fig. 1-1 and press the channel button (06) on the remote control to select "V. SIZE".
3. Press the VOL. UP/DOWN button on the remote control until the SHIFT quantity of the OVER SCAN on upside and downside becomes $10 \pm 2\%$.
4. Receive a broadcast and check if the picture is normal.

2-8: VERTICAL SHIFT

NOTE: Adjust after performing adjustments in section 2-7

1. Receive the crosshatch signal from the Pattern Generator.
2. Activate the adjustment mode display of Fig. 1-1 and press the channel button (07) on the remote control to select "V.SFT".
3. Press the VOL. UP/DOWN button on the remote control until the horizontal line becomes fit to the notch of the shadow mask.

2-9: OSD HORIZONTAL

1. Activate the adjustment mode display of Fig. 1-1.
2. Press the VOL. UP/DOWN button on the remote control until the difference of A and B becomes minimum. (Refer to Fig. 2-3)

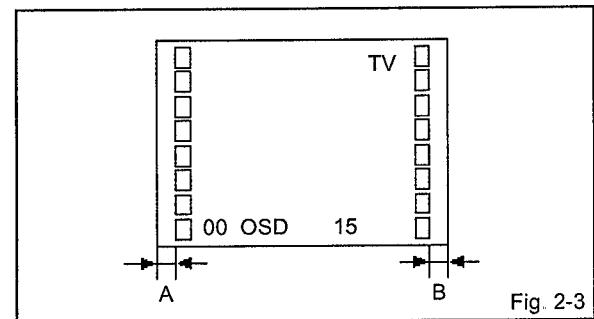

2-10: VIF VCO

1. Place the set with Aging Test for more than 10 minutes.
2. Receive an 80dB monoscope pattern.
3. Connect the digital voltmeter between the pin 5 of CP601 and the GND.
4. Activate the adjustment mode display of Fig. 1-1 and press the channel button (03) on the remote control to select "V.VCO".
5. Press the VOL. UP/DOWN button on the remote control until the digital voltmeter is 2.5V.

2-11: SUB BRIGHTNESS

1. Receive an 70dB monoscope pattern.
2. Activate the adjustment mode display of Fig. 1-1 and press the channel button (13) on the remote control to select "BRI.CENT".
3. Press the VOL. UP/DOWN button on the remote control until the screen begin to shine.
4. Press the TV/AV button on the remote to set to the AV mode. Then perform the above adjustment 2, 3.

2-12: SUB CONTRAST

1. Receive an 70dB the color bar pattern.
2. Activate the adjustment mode display of Fig. 1-1 press the channel button (17) on the remote control to select "CONT.MAX".
3. Press the VOL. UP/DOWN button on the remote control until the white color level is adjusted to 420 ± 30 NIT.
4. Press the TV/AV button on the remote to set to the AV mode. Then perform the above adjustment 2, 3.

ELECTRICAL ADJUSTMENTS

3. PURITY AND CONVERGENCE ADJUSTMENTS

NOTE

1. Turn the unit on and let it warm up for at least 30 minutes before performing the following adjustments.
2. Place the CRT surface facing east or west to reduce the terrestrial magnetism.
3. Turn ON the unit and demagnetize with a Degauss Coil.

3-1: STATIC CONVERGENCE (ROUGH ADJUSTMENT)

1. Tighten the screw for the magnet. Refer to the adjusted CRT for the position. **(Refer to Fig. 3-1)**
If the deflection yoke and magnet are in one body, untighten the screw for the body.
2. Receive the green raster pattern from the color bar generator.
3. Slide the deflection yoke until it touches the funnel side of the CRT.
4. Adjust center of screen to green, with red and blue on the sides, using the pair of purity magnets.
5. Switch the color bar generator from the green raster pattern to the crosshatch pattern.
6. Combine red and blue of the 3 color crosshatch pattern on the center of the screen by adjusting the pair of 4 pole magnets.
7. Combine red/blue (magenta) and green by adjusting the pair of 6 pole magnets.
8. Adjust the crosshatch pattern to change to white by repeating steps 6 and 7.

3-2: PURITY

NOTE

Adjust after performing adjustments in section 3-1.

1. Receive the green raster pattern from color bar generator.
2. Adjust the pair of purity magnets to center the color on the screen.
Adjust the pair of purity magnets so the color at the ends are equally wide.
3. Move the deflection yoke backward (to neck side) slowly, and stop it at the position when the whole screen is green.
4. Confirm red and blue colors.
5. Adjust the slant of the deflection yoke while watching the screen, then tighten the fixing screw.

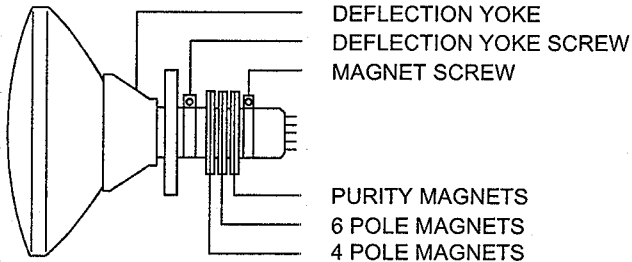

Fig. 3-1

3-3: STATIC CONVERGENCE

NOTE

Adjust after performing adjustments in section 3-2.

1. Receive the crosshatch pattern from the color bar generator.
2. Combine red and blue of the 3 color crosshatch pattern on the center of the screen by adjusting the pair of 4 pole magnets.
3. Combine red/blue (magenta) and green by adjusting the pair of 6 pole magnets.

3-4: DYNAMIC CONVERGENCE

NOTE

Adjust after performing adjustments in section 3-3.

1. Adjust the differences around the screen by moving the deflection yoke upward/downward and right/left. **(Refer to Fig. 3-2-a)**
2. Insert three wedges between the deflection yoke and CRT funnel to fix the deflection yoke. **(Refer to Fig. 3-2-b)**

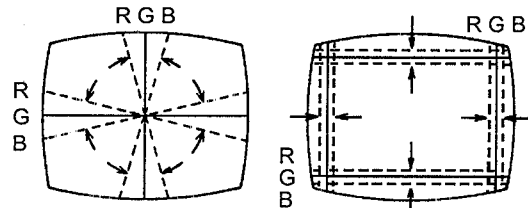

UPWARD/DOWNWARD SLANT RIGHT/LEFT SLANT

Fig. 3-2-a

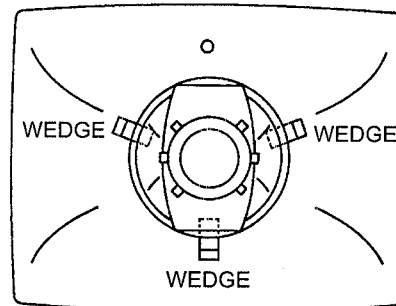

WEDGE POSITION

Fig. 3-2-b

ELECTRICAL ADJUSTMENTS

4. ELECTRICAL ADJUSTMENT PARTS LOCATION GUIDE (WIRING CONNECTION)

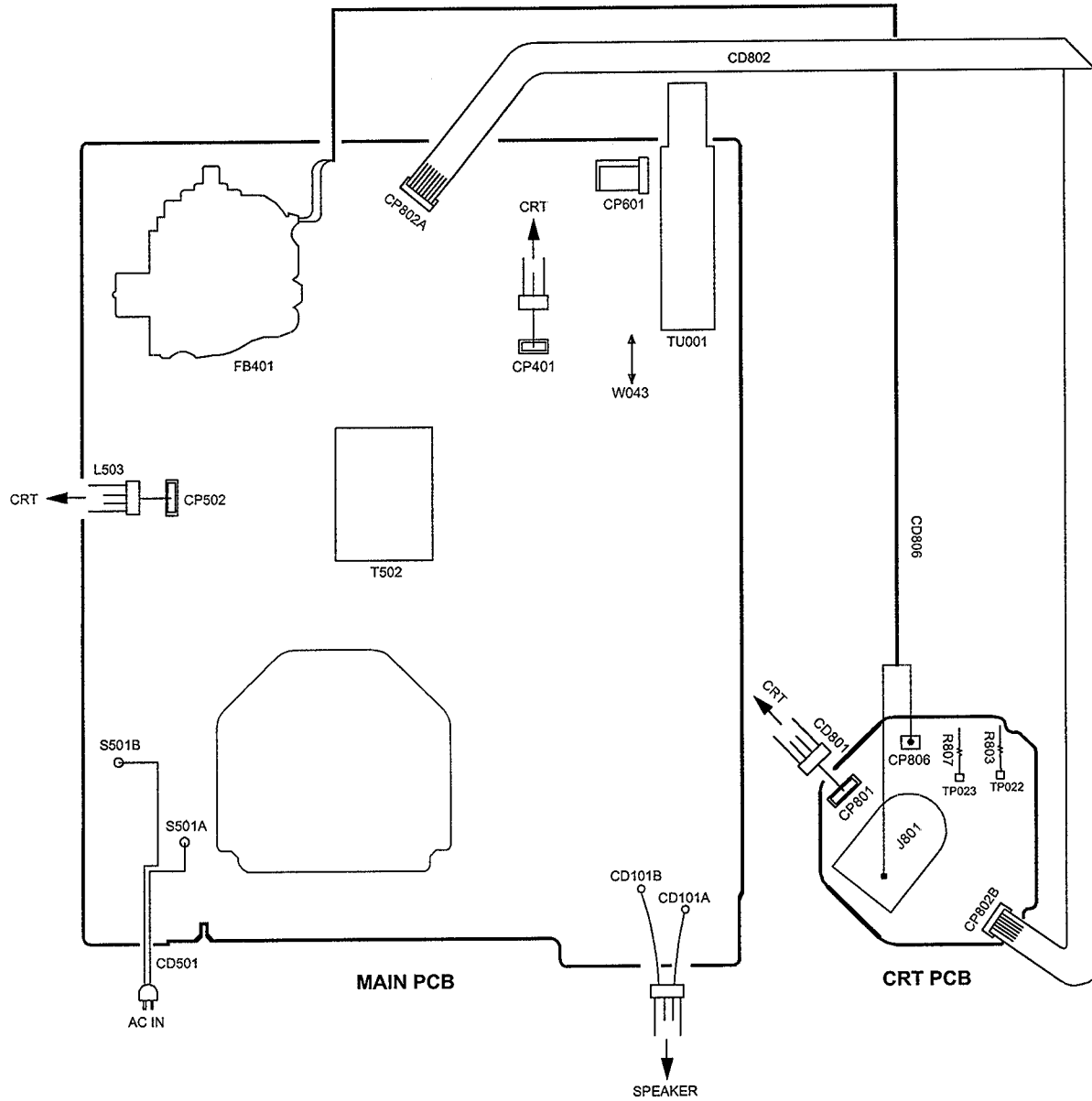

BLOCK DIAGRAM

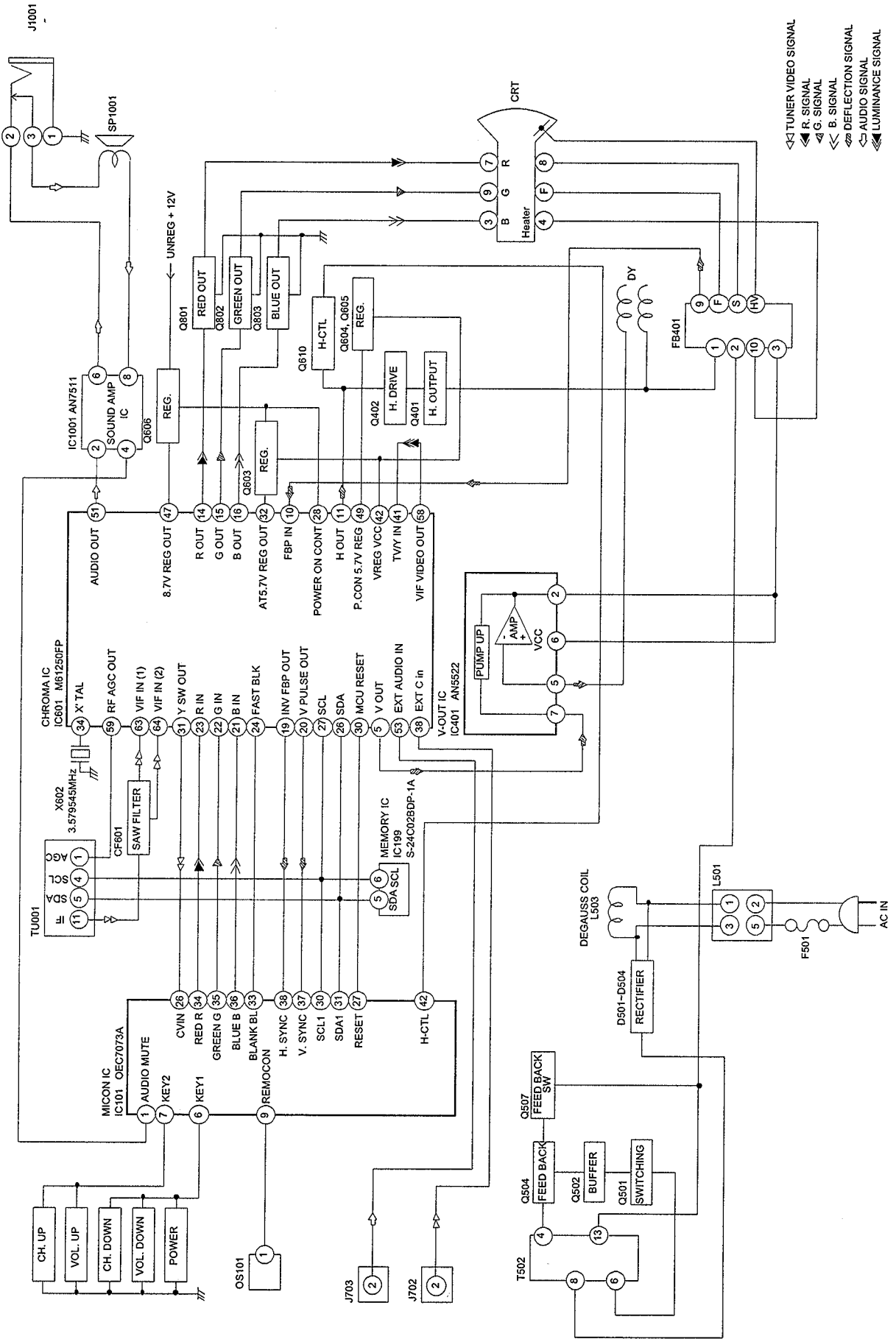

- ◁ TUNER VIDEO SIGNAL
- ◁ R. SIGNAL
- ◁ G. SIGNAL
- ◁ B. SIGNAL
- ◁ DEFLECTION SIGNAL
- ◁ AUDIO SIGNAL
- ◁ LUMINANCE SIGNAL

PRINTED CIRCUIT BOARDS
MAIN/CRT (INSERTED PARTS)
SOLDER SIDE

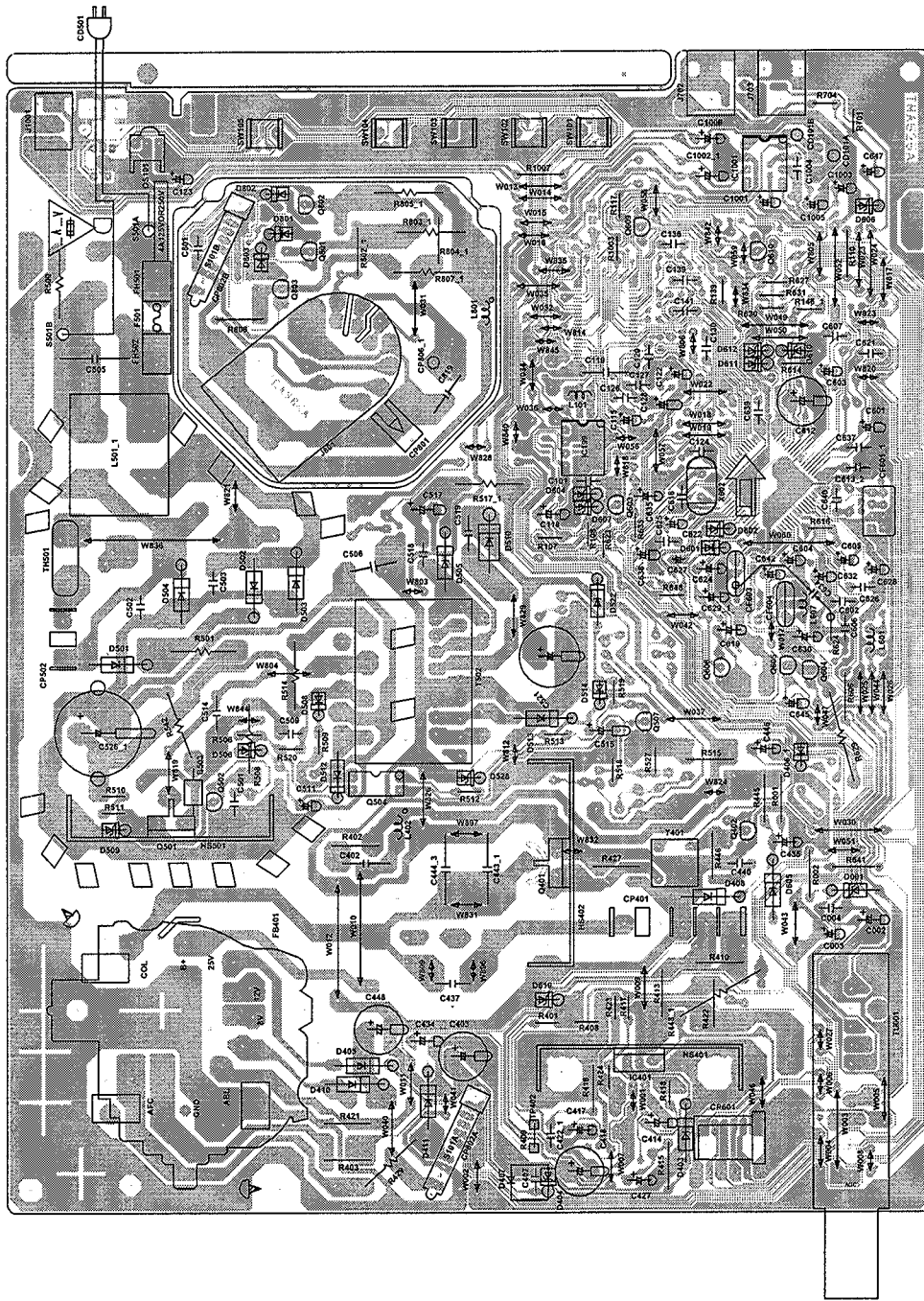

PRINTED CIRCUIT BOARDS
MAIN/CRT (CHIP MOUNTED PARTS)
SOLDER SIDE

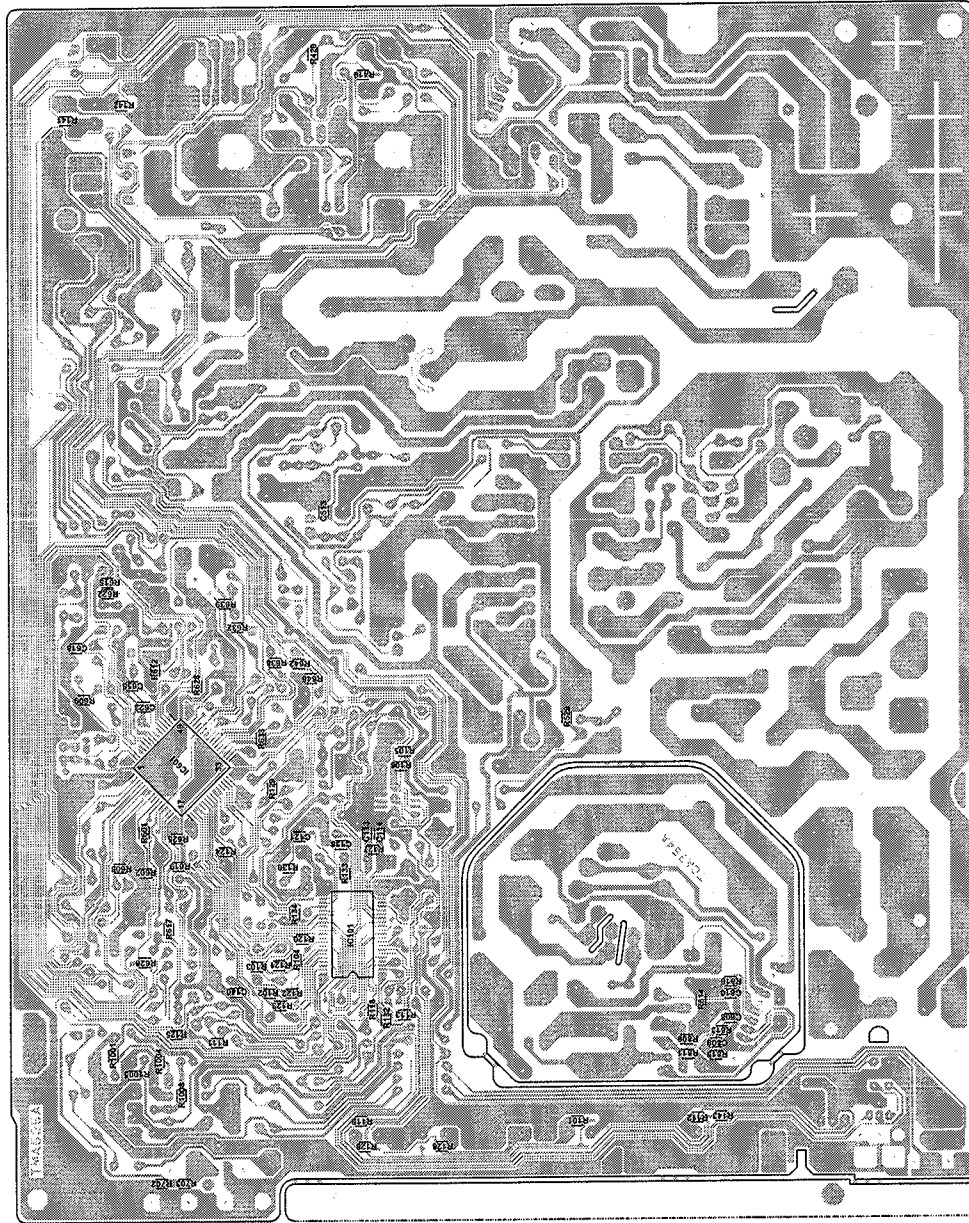

MICON/TUNER SCHEMATIC DIAGRAM (MAIN PCB)

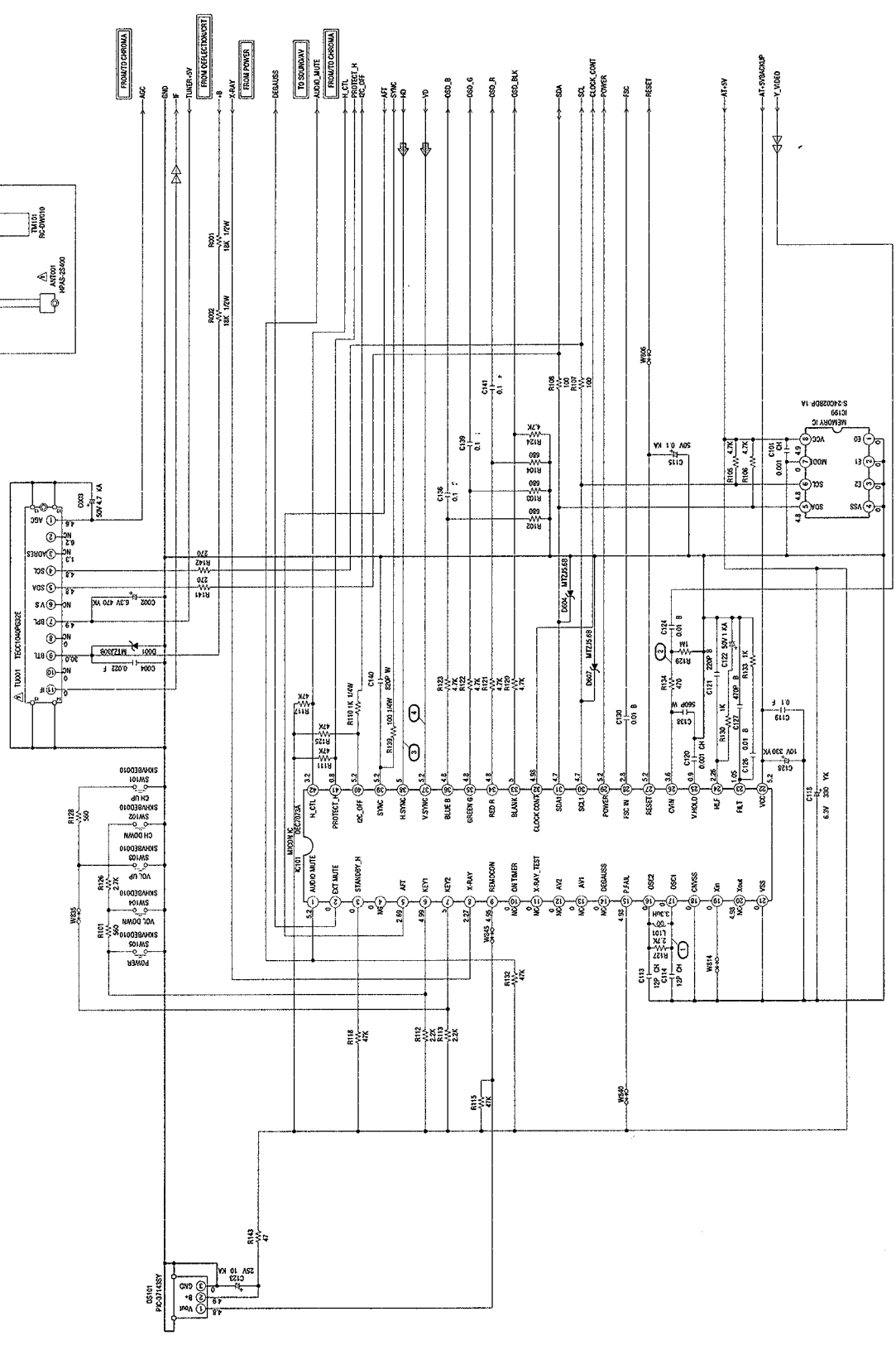
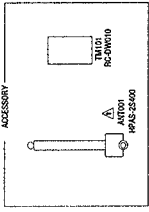

MARKER
MARKS

DEFLECTION SIGNAL
TUNER/VIDEO SIGNAL
R SIGNAL
G SIGNAL
B SIGNAL

ATTENTION: LES PIÈCES MARQUÉES PAR UN Δ ÉTAIENT DANGEREUSES AU MOMENT DE VUE SÉQUITE DANS LA MONTAGE DES PIÈCES.

CAUTION: SINCE THESE PARTS MARKED BY Δ ARE CRITICAL FOR SAFETY USE ONLY DESCRIBED IN PARTS LIST ONLY.

NOTE: THE CAUSE OF LOSS OF LOCK MAY BE CAUSED BY THE TECHNICAL TESTS WHEN THE SIGNAL BROADCAST WAS RECEIVED IN GOOD CONDITION AND PARTURE IS NORMAL.

NOTE: THIS SCHEMATIC DIAGRAM IS THE LATEST AT THE TIME OF PRINTING AND SUBJECT TO CHANGE WITHOUT NOTICE.

A B C D E F G H 8 7 6 5 4 3 2 1 G-2 G-1

CHROMA SCHEMATIC DIAGRAM (MAIN PCB)

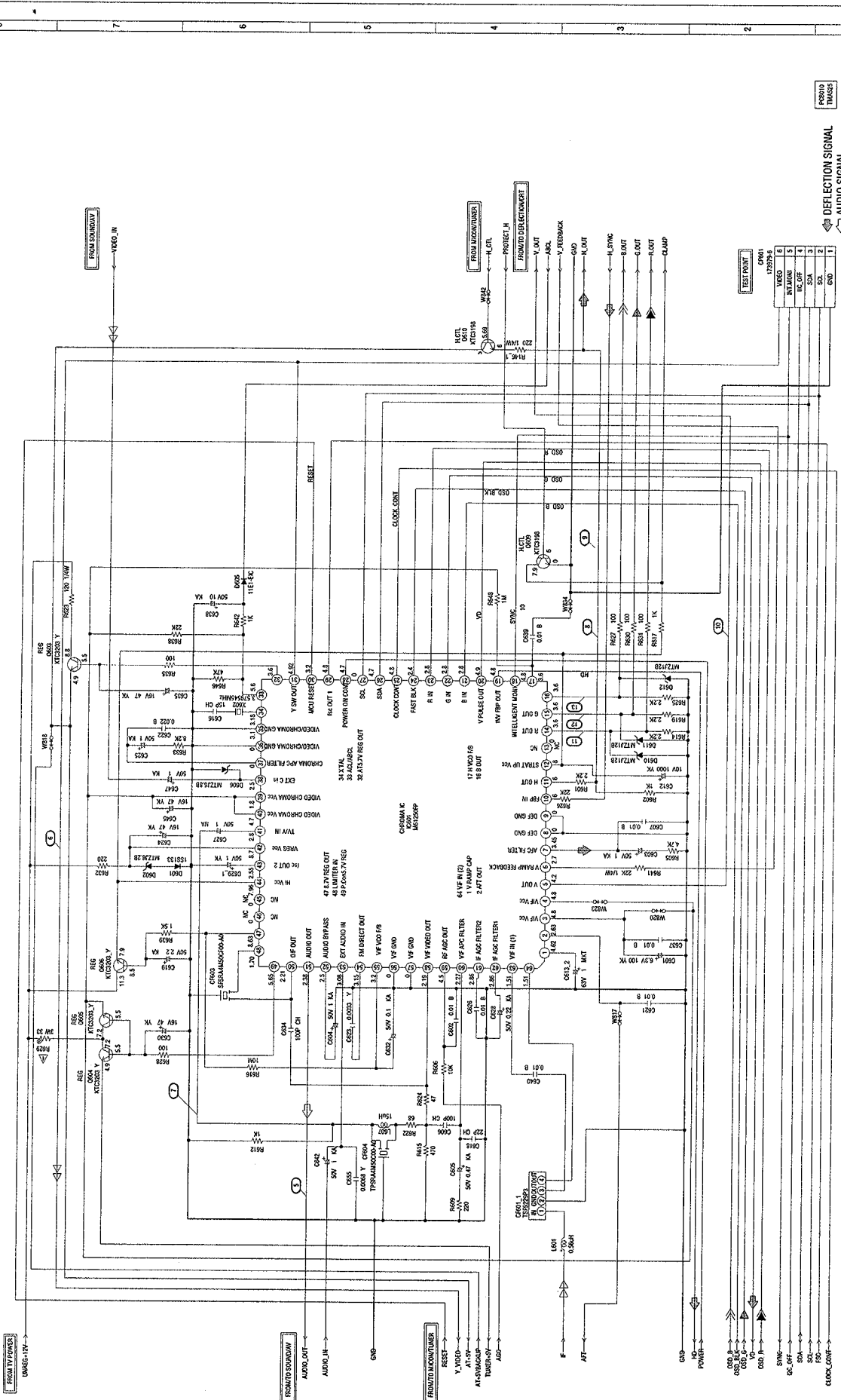

DEFLECTION SIGNAL
 AUDIO SIGNAL
 TUNER VIDEO SIGNAL
 R-SIGNAL
 G-SIGNAL
 B-SIGNAL

CAUTION: SINCE THESE PARTS MARKED BY Δ ARE CRITICAL FOR SAFETY USE DIMS MUST BE USED IN PARTS LIST ONLY.

ATTENTION: LES PIÈCES REPAREES PAR UN Δ ETANT CRITIQUEMENT IMPORTANTES POUR LA SECURITE, UTILISEZ-LES SEULEMENT EN SE REPORTANT A LA LISTE DES PIÈCES DANS LA NOMBREUSE TITRE DES PIÈCES.

NOTE: THIS SCHEMATIC DIAGRAM IS THE LATEST AT THE TIME OF PRINTING AND SUBJECT TO CHANGE WITHOUT NOTICE.

NOTE: THE CAPACITORS OF THIS PART WAS MEASURED WITH THE T.M.M. SYSTEM. THE CAPACITANCE WAS RECHECKED IN GOOD CONDITION AND PUT IN THE ORIGINAL.

NOTE: THE RESISTOR MARKED F IS FUSE RESISTOR. THE ALUM. ELECTROLYTIC CAPACITOR MARKED NP IS NON POLAR ONE.

REST POINT	
VIDEO	17979.6
H. OUT	1
V. OUT	2
R-SIGNAL	3
G-SIGNAL	4
B-SIGNAL	5
CLAMP	6
END	7

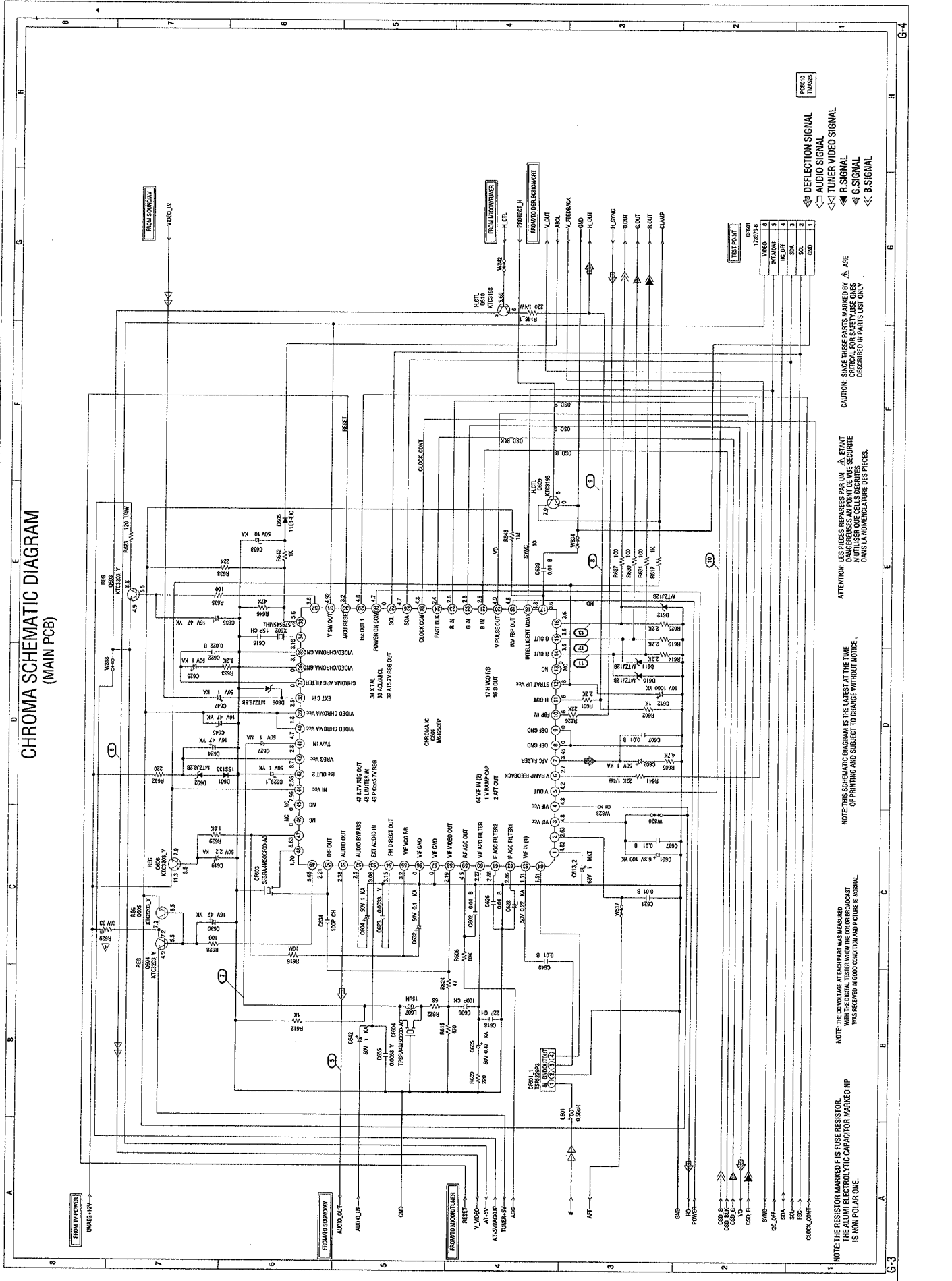

TV POWER SCHEMATIC DIAGRAM (MAIN PCB)

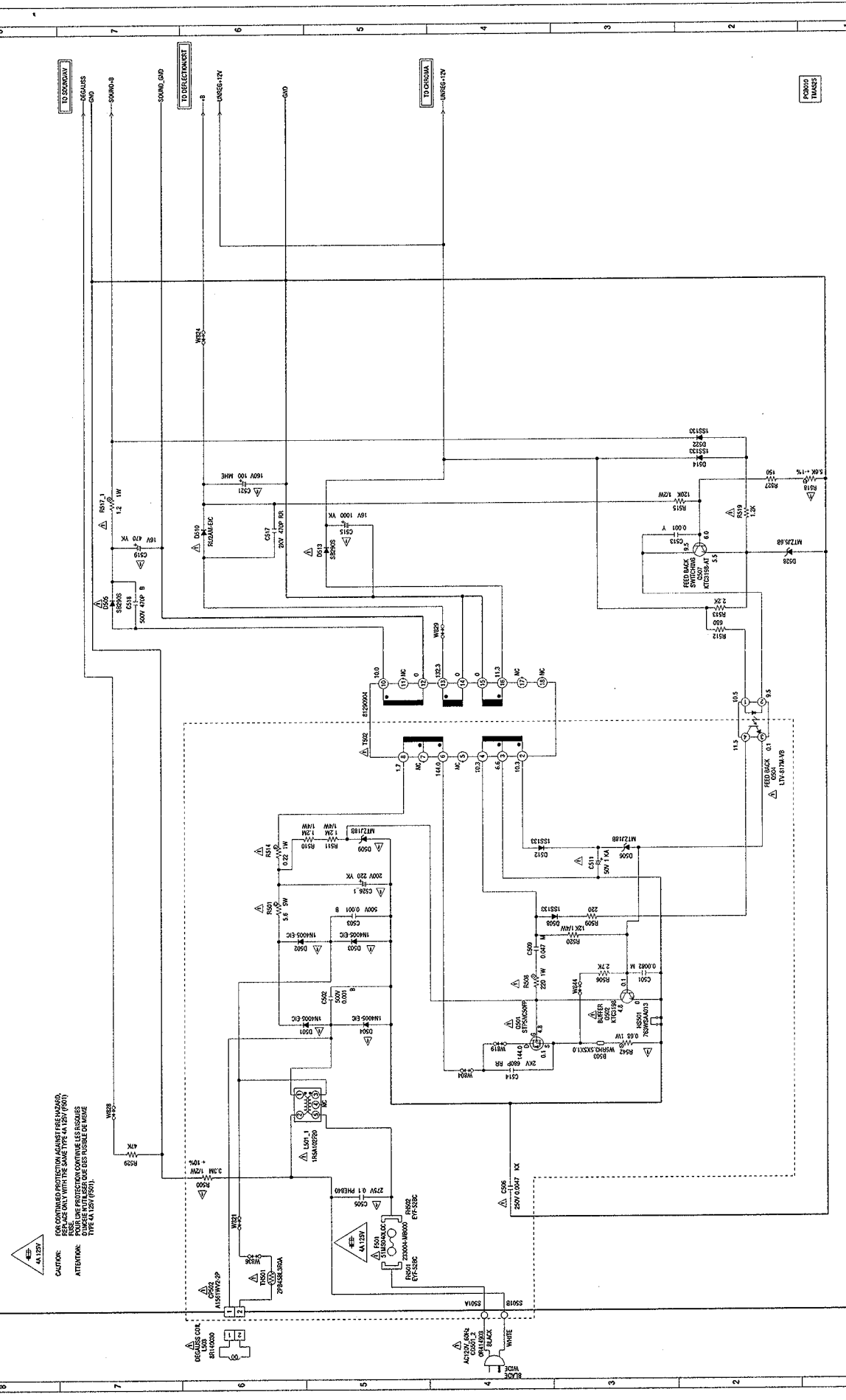

FOR CONTINUED PROTECTION AGAINST FIRE HAZARD, REPAIRS SHOULD BE MADE ONLY WITH THE SAME TYPE 4A 125V (F601) FUSE. CONSULT THE SERVICE MANUAL FOR THE LOCATION OF THE FUSE. TYPE 4A 125V (F601).

CAUTION: SINCE THESE PARTS MARKED BY Δ ARE DESCRIBED IN PARTS LIST ONLY.

ATTENTION: LES PIÈCES REPAREES PAR UN Δ SONT DÉCRITES DANS LA NOMENCLATURE DES PIÈCES.

NOTE: THE DC VOLTAGE AT EACH PART WAS MEASURED WITH THE LOAD (TUBE) CONNECTED AND THE AC VOLTAGE WAS MEASURED IN THIS POSITION. THE DC VOLTAGE IS SUBJECT TO CHANGE WITHOUT NOTICE.

NOTE: THE RESISTOR MARKED F IS FUSE RESISTOR. THE ALUMI ELECTROLYTIC CAPACITOR MARKED AP IS NON POLAR ONE.

NOTE: THE DC VOLTAGE AT EACH PART WAS MEASURED WITH THE LOAD (TUBE) CONNECTED AND THE AC VOLTAGE WAS MEASURED IN THIS POSITION. THE DC VOLTAGE IS SUBJECT TO CHANGE WITHOUT NOTICE.

NOTE: THE RESISTOR MARKED F IS FUSE RESISTOR. THE ALUMI ELECTROLYTIC CAPACITOR MARKED AP IS NON POLAR ONE.

DEFLECTION/CRT SCHEMATIC DIAGRAM (MAIN PCB)

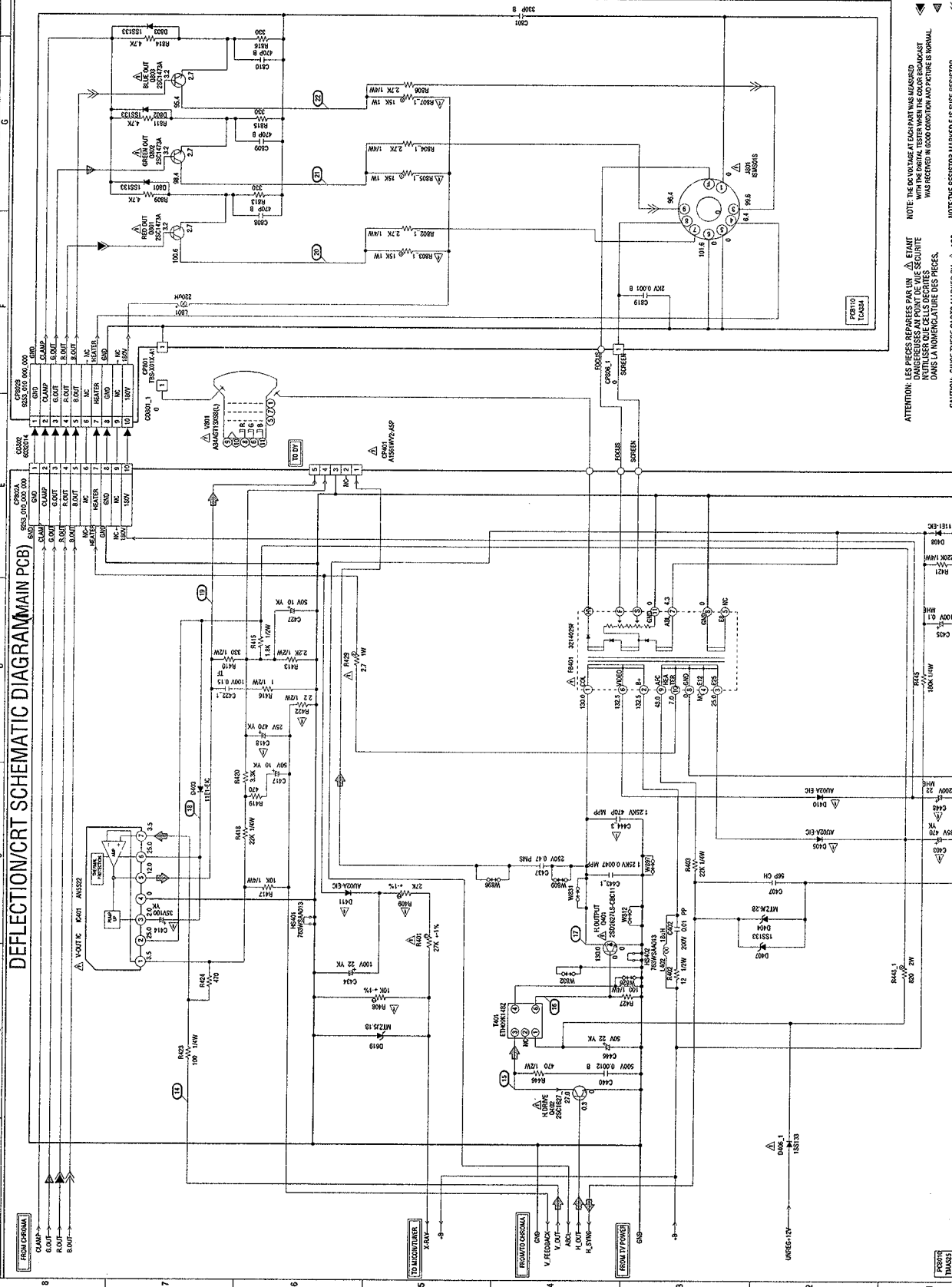

ATTENTION: LES PIÈCES REPAREES PAR UN Δ ET/OU DAMAGÉES AU POINT DE VUE SECURITE INDICUES QUE LES CELLES DÉCRITES DANS LA Nomenclature DES PIÈCES.

NOTE: THE PIECES REPAIRED BY A Δ ET/OU DAMAGED AT POINT OF VIEW SECURITE INDICATED IN THE PARTS LIST DESCRIBED IN THIS SCHEMATIC DIAGRAM.

CAUTION: SINCE THESE PARTS MARKED BY Δ ARE CRITICAL FOR SAFETY, USE ONLY THOSE DESCRIBED IN PARTS LIST ONLY.

NOTE: THE RESISTOR MARKED WITH Δ ARE ALUMINUM ELECTROLYTIC CAPACITOR MARKED HP IS FROM POLARISE.

NOTE: THIS SCHEMATIC DIAGRAM IS THE LATEST AT THE TIME OF PRINTING AND SUBJECT TO CHANGE WITHOUT NOTICE.

FROM EXTERNAL
CLAMP
G.OFF
R.OFF
S.OFF

TO REPRODUCERS
RAMP

FROM TV POWER
V. REG. 12V
H. LINE
H. SYNC
GND

FROM
D442.1
185133

8
7
6
5
4
3
2
1

H
G
F
E
D
C
B
A

G-8
G-7

SOUND/AV SCHEMATIC DIAGRAM (MAIN PCB)

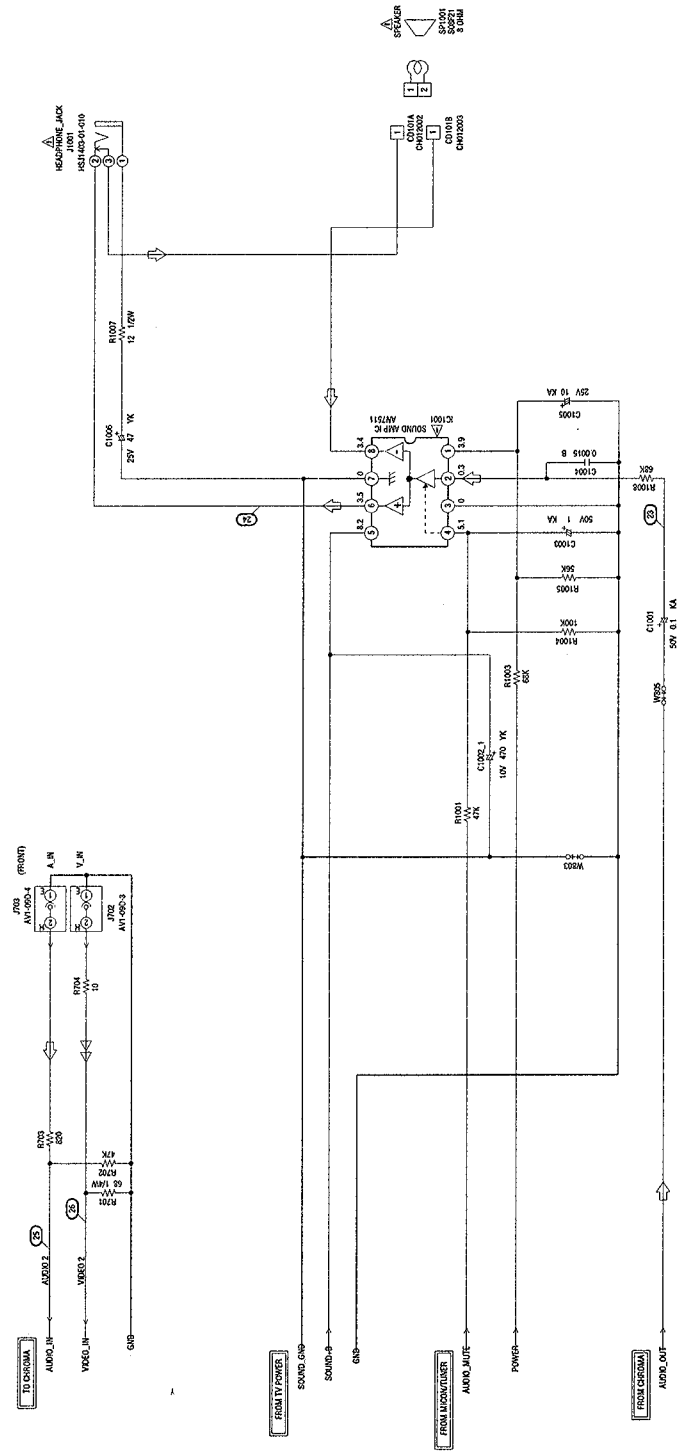

NOTE: THE DATE AS AT EACH PART NUMBER.
WITH THE ORIGINAL TESTER UNDER THE COLOR BROADCAST
WAS RECEIVED IN GOOD CONDITION AND PICTURE IS NORMAL.

NOTE: THIS SCHEMATIC DIAGRAM IS THE LATEST AT THE TIME
OF PRINTING AND SUBJECT TO CHANGE WITHOUT NOTICE.

CAUTION: SINCE THESE PARTS MARKED BY Δ ARE
REPLACEMENT PARTS, THEY ARE NOT THE ORIGINAL
DESCRIBED IN PARTS LIST ONLY.

ATTENTION: LES PIÈCES REPAREES PAR UN Δ ETANT
DES PIÈCES DE REMPLACEMENT, ELLES NE SONT PAS LES
MÊMES QUE LES PIÈCES D'ORIGINE.
DANS LA NOMENCLATURE DES PIÈCES.

POPORO
TMA555

A B C D E F G H 1 2 3 4 5 6 7 8 G-9 G-10

WAVEFORMS

MICON/TUNER

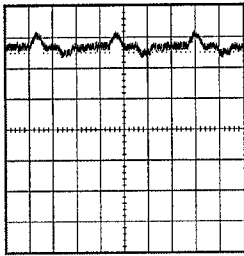

① 200mV 5ms/div

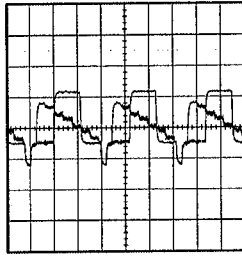

⑥ 0.5V 20μs/div

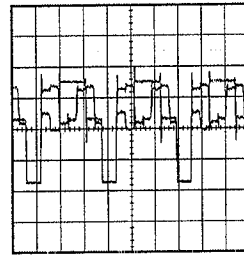

⑪ 1V 20μs/div

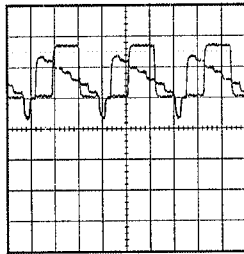

② 0.5V 20μs/div

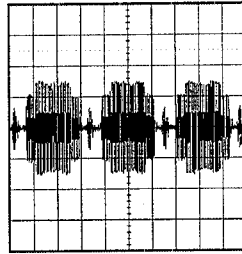

⑦ 200mV 20μs/div

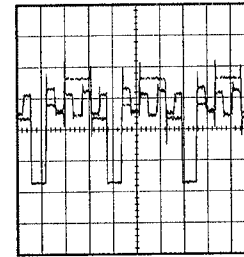

⑫ 1V 20μs/div

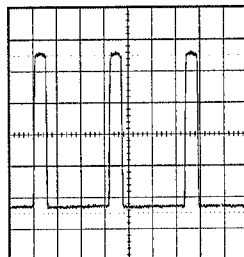

③ 200mV 20μs/div

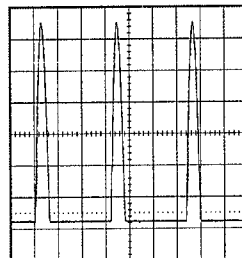

⑧ 20V 20μs/div

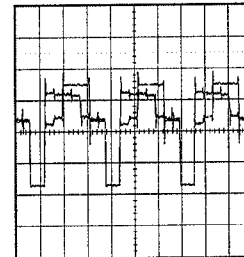

⑬ 1V 20μs/div

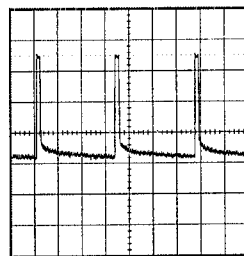

④ 200mV 5ms/div

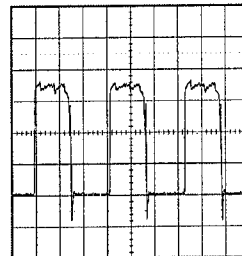

⑨ 200mV 20μs/div

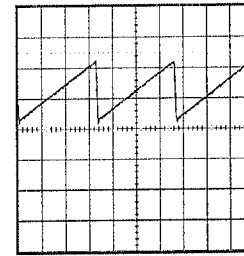

⑭ 0.5V 5ms/div

CHROMA

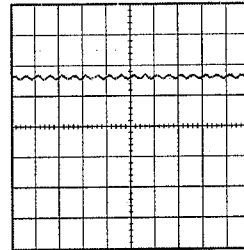

⑤ 0.5V 2ms/div

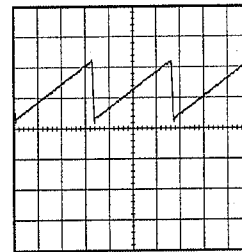

⑩ 0.5V 5ms/div

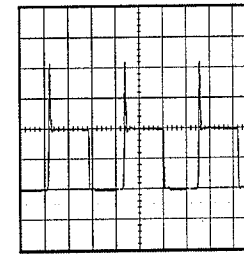

⑮ 20V 20μs/div

DEFLECTION/CRT

NOTE: The following waveforms were measured at the point of the corresponding balloon number in the schematic diagram

WAVEFORMS

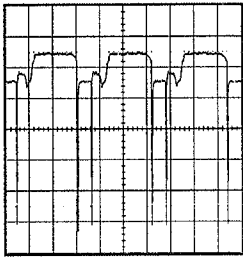

①⑥ 2V 20 μ s/div

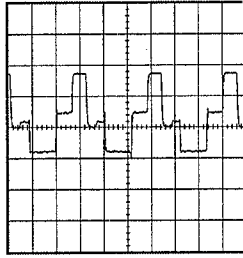

②① 50V 20 μ s/div

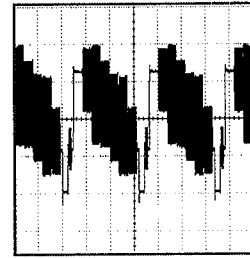

②⑥ 500mV 20 μ s/div

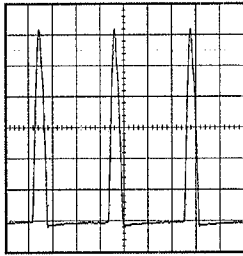

①⑦ 200V 20 μ s/div

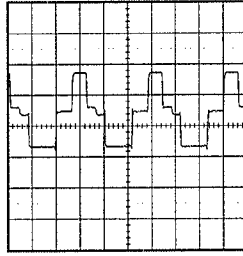

②② 50V 20 μ s/div

SOUND/AV

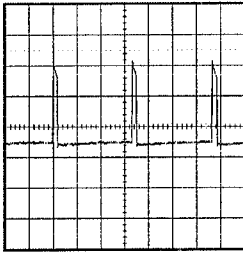

①⑧ 10V 5ms/div

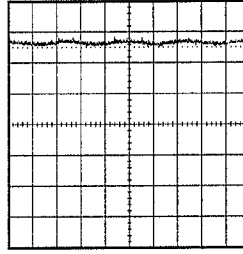

②③ 0.5V 1ms/div

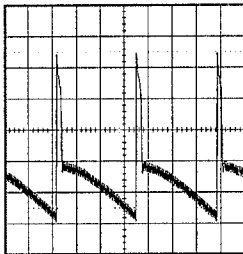

①⑨ 10V 5ms/div

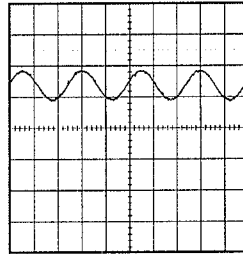

②④ 1V 1ms/div

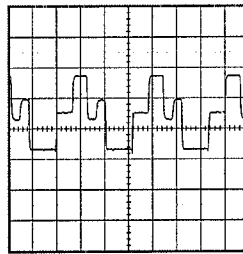

②⑩ 50V 20 μ s/div

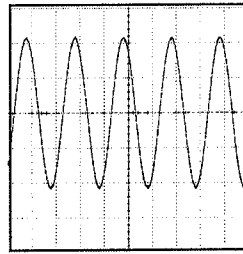

②⑤ 200mV 500 μ s/div

NOTE: The following waveforms were measured at the point of the corresponding balloon number in the schematic diagram.

MECHANICAL EXPLODED VIEW

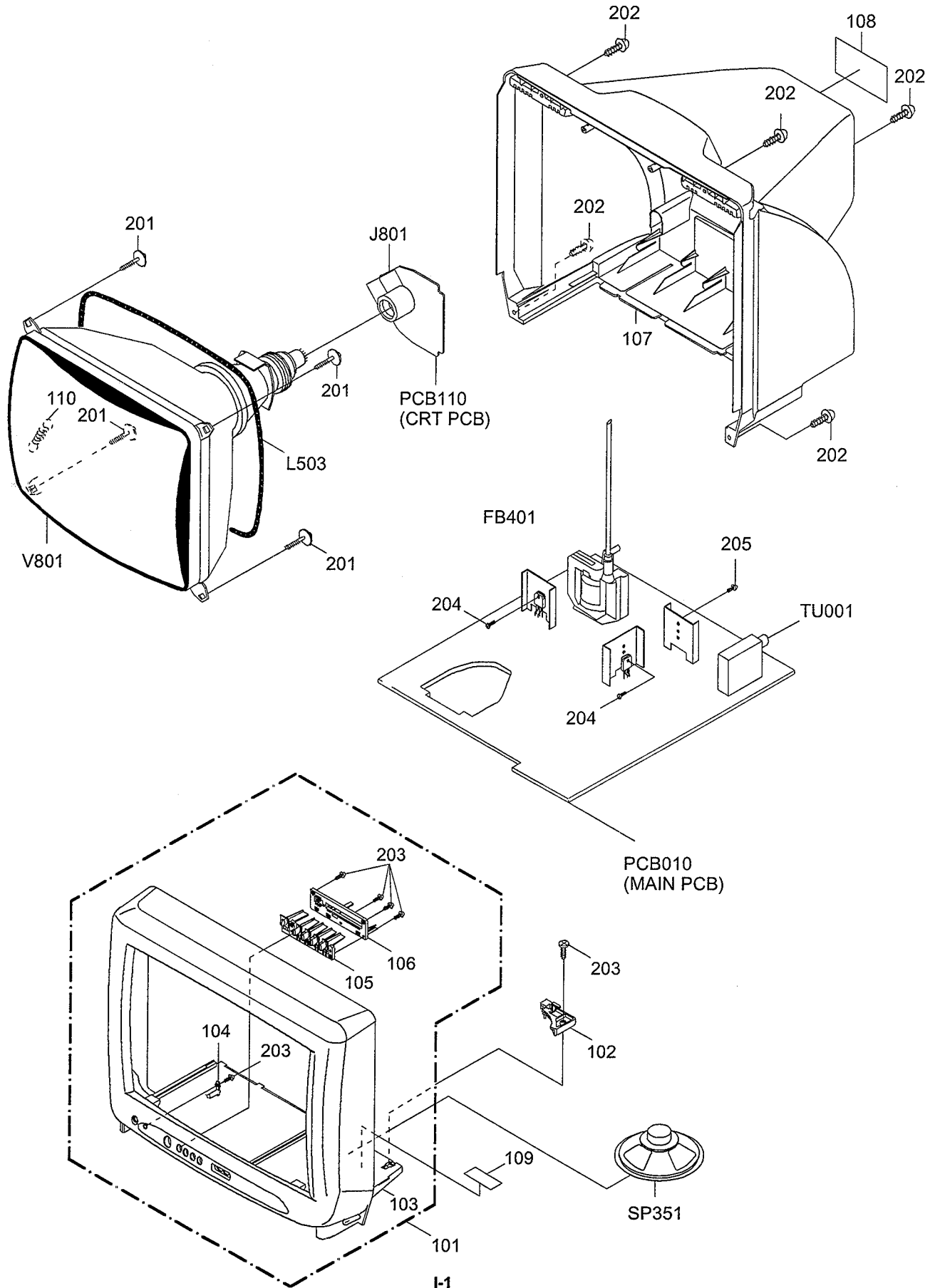

MECHANICAL REPLACEMENT PARTS LIST

REF. NO.	PART NO.	DESCRIPTION
101	A3L103A720	CABINET,FRONT ASS'Y
102	735WPA0396	SPEAKER,HOLDER
103	701WPJA927	CABINET,FRONT
104	713WPA0093	GUIDE,REMOCON
105	735WPAA344	BUTTON,FRAME
106	735WPA0398	BUTTON,HOLDER
107	702WPAA134	CABINET,BACK
108	722019A087	SHEET,RATING
109	7230006755	SHEET,CAUTION
110	741WUA0019	SPRING,EARTH
201	8121J50B54	SCREW,TAPPING(B0) GW20 5x28
202	8117540A64	SCREW,TAPPING(B0) TRUSS 4x16
203	8110630A04	SCREW,TAP TITE(P) BRAZIER 3x10
204	8109I30A04	SCREW,TAP TITE(B) WH7 3x10
205	8109630802	SCREW,TAP TITE(B) BRAZIER 3x8
---	JB5Z0300	POLYBAG,INSTRUCTION
---	J3L10301	INSTRUCTION BOOK
---	J5120917	REGISTRATION CARD
---	J5160302	WARRANTY CARD
---	A3L103C975	INSTRUCTION BOOK KIT
---	791WHA0023	LAMIFILM BAG
---	792WHA0225	PACKAGE, TOP
---	792WHA0226	PACKAGE, BOTTOM
---	793WCDB181	GIFT BOX

ELECTRICAL REPLACEMENT PARTS LIST

REF. NO.	PART NO.	DESCRIPTION	REF. NO.	PART NO.	DESCRIPTION
RESISTORS			RESISTORS		
R001	R002T2183J	RC 18K OHM 1/2W	R602	R903N8102J	RC 1K OHM 1/8W
R002	R002T2183J	RC 18K OHM 1/2W	R605	R903N8472J	RC 4.7K OHM 1/8W
R101	R903N8561J	RC 560 OHM 1/8W	R606	R001T6103J	RC 10K OHM 1/8W
R102	R903N8821J	RC 820 OHM 1/8W	R609	R903N8221J	RC 220 OHM 1/8W
R103	R903N8821J	RC 820 OHM 1/8W	R612	R903N8102J	RC 1K OHM 1/8W
R104	R903N8821J	RC 820 OHM 1/8W	R614	R001T6222J	RC 2.2K OHM 1/6W
R105	R903N8472J	RC 4.7K OHM 1/8W	R615	R903N8471J	RC 470 OHM 1/8W
R106	R903N8472J	RC 4.7K OHM 1/8W	R616	R001T6106J	RC 10M OHM 1/6W
R107	R001T6101J	RC 100 OHM 1/6W	R617	R903N8102J	RC 1K OHM 1/8W
R108	R001T6101J	RC 100 OHM 1/6W	R619	R903N8222J	RC 2.2K OHM 1/8W
R110	R002T4102J	RC 1K OHM 1/4W	R622	R903N8680J	RC 68 OHM 1/8W
R111	R903N8473J	RC 47K OHM 1/8W	R623	R002T4121J	RC 120 OHM 1/4W
R112	R903N8222J	RC 2.2K OHM 1/8W	R624	R001T6470J	RC 47 OHM 1/6W
R113	R903N8222J	RC 2.2K OHM 1/8W	R625	R903N8222J	RC 2.2K OHM 1/8W
R115	R903N8473J	RC 47K OHM 1/8W	R626	R903N8223J	RC 22K OHM 1/8W
R117	R001T6473J	RC 47K OHM 1/6W	R627	R001T6101J	RC 100 OHM 1/8W
R118	R903N8473J	RC 47K OHM 1/8W	R628	R903N8101J	RC 100 OHM 1/8W
R120	R903N8472J	RC 4.7K OHM 1/8W	△ R629	R3X28B330J	R,METAL OXIDE 33 OHM 3W
R121	R903N8472J	RC 4.7K OHM 1/8W	R630	R001T6101J	RC 100 OHM 1/6W
R122	R903N8472J	RC 4.7K OHM 1/8W	R631	R001T6101J	RC 100 OHM 1/6W
R123	R903N8472J	RC 4.7K OHM 1/8W	R632	R903N8221J	RC 220 OHM 1/8W
R124	R903N8472J	RC 4.7K OHM 1/8W	R633	R903N8822J	RC 8.2K OHM 1/8W
R125	R903N8473J	RC 47K OHM 1/8W	R635	R001T6101J	RC 100 OHM 1/6W
R126	R903N8272J	RC 2.7K OHM 1/8W	R638	R903N8223J	RC 22K OHM 1/8W
R127	R903N8272J	RC 2.7K OHM 1/8W	R639	R903N8152J	RC 1.5K OHM 1/8W
R128	R903N8561J	RC 560 OHM 1/8W	R641	R002T4223J	RC 22K OHM 1/4W
R129	R903N8105J	RC 1M OHM 1/8W	R642	R903N8102J	RC 1K OHM 1/8W
R130	R903N8102J	RC 1K OHM 1/8W	R646	R903N8473J	RC 47K OHM 1/8W
R132	R903N8473J	RC 47K OHM 1/8W	R648	R001T6105J	RC 1M OHM 1/6W
R133	R903N8102J	RC 1K OHM 1/8W	R701	R002T4680J	RC 68 OHM 1/4W
R134	R903N8471J	RC 470 OHM 1/8W	R702	R903N8473J	RC 47K OHM 1/8W
R139	R002T4101J	RC 100 OHM 1/4W	R703	R903N8821J	RC 820 OHM 1/8W
R141	R903N8271J	RC 270 OHM 1/8W	R704	R001T6100J	RC 10 OHM 1/6W
R142	R903N8271J	RC 270 OHM 1/8W	R802	R002T4272J	RC 2.7K OHM 1/4W
R143	R903N8470J	RC 47 OHM 1/8W	△ R803	R3X181153J	R,METAL OXIDE 15K OHM 1W
R146	R002T4221J	RC 220 OHM 1/4W	R804	R002T4272J	RC 2.7K OHM 1/4W
△ R401	R4X5T6273F	R,METAL 27K OHM 1/6W	△ R805	R3X181153J	R,METAL OXIDE 15K OHM 1W
R402	R002T2120J	RC 12 OHM 1/2W	R806	R002T4272J	RC 2.7K OHM 1/4W
R403	R002T4223J	RC 22K OHM 1/4W	△ R807	R3X181153J	R,METAL OXIDE 15K OHM 1W
△ R408	R4X5T6103F	R,METAL 10K OHM 1/6W	R809	R903N8472J	RC 4.7K OHM 1/8W
△ R409	R4X5T6273F	R,METAL 27K OHM 1/6W	R811	R903N8472J	RC 4.7K OHM 1/8W
R410	R002T2331J	RC 330 OHM 1/2W	R813	R903N8331J	RC 330 OHM 1/8W
R413	R002T2222J	RC 2.2K OHM 1/2W	R814	R903N8472J	RC 4.7K OHM 1/8W
R415	R002T2182J	RC 1.8K OHM 1/2W	R815	R903N8331J	RC 330 OHM 1/8W
R416	R002T2010J	RC 1 OHM 1/2W	R816	R903N8331J	RC 330 OHM 1/8W
R417	R002T4103J	RC 10K OHM 1/4W	R1001	R903N8473J	RC 47K OHM 1/8W
R418	R002T4223J	RC 22K OHM 1/4W	R1003	R001T6683J	RC 68K OHM 1/6W
R419	R903N8471J	RC 470 OHM 1/8W	R1004	R903N8104J	RC 100K OHM 1/8W
R420	R903N8332J	RC 3.3K OHM 1/8W	R1005	R903N8563J	RC 56K OHM 1/8W
R421	R002T4224J	RC 220K OHM 1/4W	R1007	R002T2120J	RC 12 OHM 1/2W
R422	R002T22R2J	RC 2.2 OHM 1/2W	R1008	R903N8683J	RC 68K OHM 1/8W
R423	R002T4101J	RC 100 OHM 1/4W	CAPACITORS		
R424	R001T6471J	RC 470 OHM 1/6W	C002	E02LT0471M	CE 470 UF 6.3V
R427	R002T4101J	RC 100 OHM 1/4W	C003	E50HU54R7M	CE 4.7 UF 50V
△ R429	R655812R7J	R,FUSE J 2.7 OHM 1W	C004	C0JTF04H4Z	CC 0.022 UF 50V F
R445	R002T4184J	RC 180K OHM 1/4W	C101	CQGTCH413J	CC 0.001 UF 50V CH
R446	R002T2471J	RC 470 OHM 1/2W	C113	CS0KCH4B1J	CC 12 PF 50V CH
R448	R3X18A821J	R,METAL OXIDE 820 OHM 2W	C114	CS0KCH4B1J	CC 12 PF 50V CH
△ R500	R0G3K2335K	RC 3.3M OHM 1/2W	C115	E50HU50R1M	CE 0.1 UF 50V
△ R501	R5Y2CD5R6J	R,CEMENT 5.6 OHM 5W	C118	E02LT0331M	CE 330 UF 6.3V
R506	R001T6272J	RC 2.7K OHM 1/6W	C119	CQGTFO415Z	CC 0.1 UF 50V F
△ R508	R3X181221J	R,METAL OXIDE 220 OHM 1W	C120	CQGTCH413J	CC 0.001 UF 50V CH
△ R509	R001T6221J	RC 220 OHM 1/6W	C121	CS0KB04H2K	CC 220 PF 50V B
R510	R002T4125J	RC 1.2M OHM 1/4W	C122	E50HU5010M	CE 1 UF 50V
R511	R002T4125J	RC 1.2M OHM 1/4W	C123	E50HU3100M	CE 10 UF 25V
R512	R001T6681J	RC 680 OHM 1/6W	C124	CQGTB0414K	CC 0.01 UF 50V B
R513	R001T6222J	RC 2.2K OHM 1/6W	C126	CQGTB0414K	CC 0.01 UF 50V B
△ R514	R63581R22J	R,FUSE 0.22 OHM 1W	C127	C0JTB05Q2K	CC 470 PF 500V B
△ R515	R002T2124J	RC 120K OHM 1/2W	C128	E02LU1331M	CE 330 UF 10V
△ R517	R3X1811R2J	R,METAL OXIDE 1.2 OHM 1W	C130	CQGTB0414K	CC 0.01 UF 50V B
△ R518	R4X5T6562F	R,METAL 5.6K OHM 1/6W	C136	CQGTFO415Z	CC 0.1 UF 50V F
△ R519	R001T6122J	RC 1.2K OHM 1/6W	C138	CS0KW04S2M	CC 560 PF 50V W
R520	R002T4123J	RC 12K OHM 1/4W	C139	CQGTFO415Z	CC 0.1 UF 50V F
R527	R001T6151J	RC 150 OHM 1/6W	C140	CS0KW04W2M	CC 820 PF 50V W
R529	R903N8473J	RC 47K OHM 1/8W	C141	CQGTFO415Z	CC 0.1 UF 50V F
△ R542	R3X181R68J	R,METAL OXIDE 0.68 OHM 1W	C402	P3N1F2103J	CCP 0.01 UF 200V
R601	R903N8222J	RC 2.2K OHM 1/8W	△ C403	E02LT4471M	CE 470 UF 35V

ELECTRICAL REPLACEMENT PARTS LIST

REF. NO.	PART NO.	DESCRIPTION	REF. NO.	PART NO.	DESCRIPTION
CAPACITORS			DIODES		
C407	CQGTCH4S1J	CC 56 PF 50V CH	D404	D97U06R21B	DIODE,ZENER MTZJ6 2B T-77
△ C414	E02LT4101M	CE 100 UF 35V	△ D405	D2WTAU02A0	DIODE SILICON AU02A-EIC
C417	E02LT5100M	CE 10 UF 50V	D406	D1VT001330	DIODE,SILICON 1SS133T-77
△ C418	E02LT3471M	CE 470 UF 25V	D407	D1VT001330	DIODE,SILICON 1SS133T-77
C422	P611T1154J	CMPL 0.15 UF 100V TF	D408	D2WT011E10	DIODE SILICON 11E1-EIC
C427	E02LT5100M	CE 10 UF 50V	△ D410	D2WTAU02A0	DIODE SILICON AU02A-EIC
△ C434	E02LT8220M	CE 22 UF 100V	△ D411	D2WTAU02A0	DIODE SILICON AU02A-EIC
C435	E5E2T80R1M	CE 0.1 UF 100V	D501	D2WXN40050	DIODE SILICON 1N4005-EIC
C437	P4J7F3474J	CMPP 0.47 UF 250V PMS	△ D502	D2WXN40050	DIODE SILICON 1N4005-EIC
C440	C0JTB05B3K	CC 0.0012UF 500V B	△ D503	D2WXN40050	DIODE SILICON 1N4005-EIC
△ C443	P4N8FJ472H	CMPP 0.0047UF 1.25KV	△ D504	D2WXN40050	DIODE SILICON 1N4005-EIC
C444	P4N8FJ471J	CMPP 470 PF 1.25KV	or △ D505	D2WXB290S0	DIODE SILICON SB290S
△ C446	C0PLRR7Q2K	CC RF 470 PF 2KV RR	D506	D97U01801B	DIODE,ZENER MTZJ18B T-77
△ C448	E02LT5220M	CE 22 UF 50V	D508	D1VT001330	DIODE,SILICON 1SS133T-77
C501	P1S3T0822J	CP 0.0082UF 50V	△ D509	D97U01801B	DIODE,ZENER MTZJ18B T-77
C502	C0JTB0513K	CC 0.001 UF 500V B	△ D510	D2WXR2AM0	DIODE SILICON RU2AM-EIC
△ C503	C0JTB0513K	CC 0.001 UF 500V B	D512	D1VT001330	DIODE,SILICON 1SS133T-77
△ C505	P2472B104M	CMP 0.1 UF 275V PHE840	△ D513	D2WXB290S0	DIODE SILICON SB290S
C506	CB3930MQ3M	CC 0.0047UF 250V	D514	D1VT001330	DIODE,SILICON 1SS133T-77
C509	P1S3T0473J	CP 0.047 UF 50V	D522	D1VT001330	DIODE,SILICON 1SS133T-77
C511	E50HU5010M	CE 1 UF 50V	D528	D97U05R61B	DIODE,ZENER MTZJ5 6B T-77
C513	CS0KY0313M	CC 0.001 UF 25V Y	D601	D1VT001330	DIODE,SILICON 1SS133T-77
C514	C0PLRR7U2K	CC 680 PF 2KV RR	D602	D97U08R21B	DIODE,ZENER MTZJ8 2B T-77
△ C515	E02LT2102M	CE 1000 UF 16V	D604	D97U05R61B	DIODE,ZENER MTZJ5 6B T-77
C517	C0PLRR7Q2K	CC 470 PF 2KV RR	D605	D2WT011E10	DIODE SILICON 11E1-EIC
C518	C0JTB05Q2K	CC 470 PF 500V B	D606	D97U06R81B	DIODE,ZENER MTZJ6.8B T-77
△ C519	E02LT2471M	CE 470 UF 16V	D607	D97U05R61B	DIODE,ZENER MTZJ5 6B T-77
C521	E5E2FB101M	CE 100 UF 160V	D610	D97U01201B	DIODE,ZENER MTZJ12B T-77
△ C526	E02LFC221M	CE 220 UF 200V	D611	D97U01201B	DIODE,ZENER MTZJ12B T-77
C601	E02LU0101M	CE 100 UF 6.3V	D612	D97U01201B	DIODE,ZENER MTZJ12B T-77
C602	CQGTB0414K	CC 0.01 UF 50V B	D619	D97U05R11B	DIODE,ZENER MTZJ5 1B T-77
C603	E50HU5010M	CE 1 UF 50V	D801	D1VT001330	DIODE,SILICON 1SS133T-77
C604	E50HU5010M	CE 1 UF 50V	D802	D1VT001330	DIODE,SILICON 1SS133T-77
C605	E50HU5R47M	CE 0.47 UF 50V	D803	D1VT001330	DIODE,SILICON 1SS133T-77
C606	CQGTCH412J	CC 100 PF 50V CH	ICS		
C607	CQGTB0414K	CC 0.01 UF 50V B	IC101	I56F07073A	IC OEC7073A
C612	E02LT1102M	CE 1000 UF 10V	IC199	A3L101C015	IC S-24C02BDP-1A
C613	P235WE105J	CMPT 1 UF 63V MKT	△ IC401	I01TD55220	IC AN5522
C616	C0JTB04E1J	CC 15 PF 50V CH	IC601	I06FC61250	IC M61250FP
C618	CS0KCH4H1J	CC 22 PF 50V CH	IC1001	I01DP75110	IC AN7511
C619	E50HT52R2M	CE 2.2 UF 50V	TRANSISTORS		
C621	CQGTB0414K	CC 0.01 UF 50V B	△ Q401	TD30026270	TRANSISTOR SILICON 2SD2627LS-CBC11
C622	CQGTB04H4K	CC 0.022 UF 50V B	△ Q402	TC5T01627Y	TRANSISTOR SILICON 2SC1627_Y(TPE2)
C623	CS0KY03L3M	CC 0.0033UF 25V Y	△ Q501	TJXG5NC500	FET STP5NC50FP
C624	E02LT2470M	CE 47 UF 16V	△ Q502	TCATC31980	TRANSISTOR,SILICON KTC3198-AT(Y,GR)
C625	E50HU5010M	CE 1 UF 50V	△ Q504	0002E00610	PHOTO COUPLER LTV-817M-VB
C626	CQGTB0414K	CC 0.01 UF 50V B	Q507	TCATC31980	TRANSISTOR,SILICON KTC3198-AT(Y,GR)
C627	E62KU5010M	CE 1 UF 50V	Q603	TCAT032034	TRANSISTOR, SILICON KTC3203_Y-AT
C628	E50HU5R22M	CE 0.22 UF 50V	Q604	TCAT032034	TRANSISTOR, SILICON KTC3203_Y-AT
C629	E02LT5010M	CE 1 UF 50V	Q605	TCAT032034	TRANSISTOR, SILICON KTC3203_Y-AT
C630	E02LT2470M	CE 47 UF 16V	Q606	TCAT032034	TRANSISTOR, SILICON KTC3203_Y-AT
C632	E50HU50R1M	CE 0.1 UF 50V	Q609	TCATC31980	TRANSISTOR,SILICON KTC3198-AT(Y,GR)
C634	CQG0CH412J	CC 100 PF 50V CH	Q610	TCATC31980	TRANSISTOR,SILICON KTC3198-AT(Y,GR)
C635	E02LT2470M	CE 47 UF 16V	△ Q801	TCKT1473A0	TRANSISTOR SILICON 2SC1473A-TA-(RQ)
C637	CQGTB0414K	CC 0.01 UF 50V B	△ Q802	TCKT1473A0	TRANSISTOR SILICON 2SC1473A-TA-(RQ)
C638	E50HU5100M	CE 10 UF 50V	△ Q803	TCKT1473A0	TRANSISTOR SILICON 2SC1473A-TA-(RQ)
C639	CQGTB0414K	CC 0.01 UF 50V B	COILS & TRANSFORMERS		
C640	CQGTB0414K	CC 0.01 UF 50V B	L101	021LA63R3K	COIL 3.3 UH
C642	E50HU5010M	CE 1 UF 50V	L402	02186G180M	COIL 18 UH
C645	E02LU2470M	CE 47 UF 16V	△ L501	029T00A7M1	COIL,LINE FILTER 1R5A102F20
C647	E50HU5010M	CE 1 UF 50V	△ L503	028R140030	COIL,DEGAUSS 8R140030
C655	CS0KY02U3M	CC 0.0068UF 16V Y	L601	021LA6R56M	COIL 0.56 UH
C801	CHGTB04L2K	CC 330 PF 50V B	L607	021LA6150K	COIL 15 UH
C808	CS0KB04Q2K	CC 470 PF 50V B	L801	021673221K	COIL 220 UH
C809	CS0KB04Q2K	CC 470 PF 50V B	T401	045009003J	TRANS,HORIZONTAL DRIVE ETH09K14BZ
C810	CS0KB04Q2K	CC 470 PF 50V B	△ T502	0481290904	TRANSFORMER,SWITCHING 81290904
C819	C0JBB0713K	CC 0.001 UF 2KV B	JACKS		
C1001	E50HU50R1M	CE 0.1 UF 50V	J702	060Q401077	RCA JACK AV1-09D-3
C1002	E02LT1471M	CE 470 UF 10V	J703	060Q401076	RCA JACK AV1-09D-4
C1003	E50HU5010M	CE 1 UF 50V	△ J801	066F120018	SOCKET,CRT UBEISMS01S
C1004	CQGTB04E3K	CC 0.0015UF 50V B	J1001	0602121012	JACK,RCA 3.5 HSJ1403-01-010
C1005	E50HU3100M	CE 10 UF 25V	SWITCHES		
C1006	E02LT3470M	CE 47 UF 25V	SW101	0504201T31	SWITCH,TACT SKHVBD010
D001	D97U03001B	DIODE,ZENER MTZJ30B T-77	SW102	0504201T31	SWITCH,TACT SKHVBD010
D403	D2WT011E10	DIODE SILICON 11E1-EIC	SW103	0504201T31	SWITCH,TACT SKHVBD010
			SW104	0504201T31	SWITCH,TACT SKHVBD010
			SW105	0504201T31	SWITCH,TACT SKHVBD010

ELECTRICAL REPLACEMENT PARTS LIST

REF. NO.	PART NO.	DESCRIPTION	
P.C. BOARD ASSEMBLIES			
PCB010	A3L101A010	PCB ASS'Y	TMA525A
PCB110	A3L101A110	PCB ASS'Y	TCA384A
MISCELLANEOUS			
ANT001	125C104001	ANTENNA,ROD	HPAS-2S400
B503	024HT03553	CORE,BEADS	W5RH3.5X5X1 0
△ CD501	120R414903	CORD AC BUSH	0R414903
CF601	1029045R7G	FILTER,SAW	TSF5229P3
CF603	1012T4R520	FILTER,CERAMIC	SFSRA4M50CF00-A0
CF604	1012T4R519	FILTER,CERAMIC TRAP	TPSRA4M50C00-A0
△ CP401	069S450089	CONNECTOR PCB SIDE	A1561WV2-A5P
△ CP502	069S420110	CONNECTOR PCB SIDE	A1561WV2-2P
CP601	069E260659	CONNECTOR PCB SIDE	00_8283_0611_00_000
CP801	069W010030	CONNECTOR PCB SIDE	TBS-X01X-A1
CD101A	06CH012002	CORD CONNECTOR	CH012002
CD101B	06CH012003	CORD CONNECTOR	CH012003
CP802A	067N010039	WIRE HOLDER	9253_010_000_000 or
	067U010049	WIRE HOLDER	B2013H02-10P
CP802B	067N010039	WIRE HOLDER	9253_010_000_000 or
	067U010049	WIRE HOLDER	B2013H02-10P
△ F501	081PC04004	FUSE	51MS040LCC
△ FB401	043214029F	TRANSFORMER FLYBACK	3214029F
FH501	06710T0006	HOLDER,FUSE	EYF-52BC
FH502	06710T0006	HOLDER,FUSE	EYF-52BC
OS101	077Q037003	REMOTE RECEIVER	PIC-37143SY
S101	WHL6032014	FLAT CABLE	AWG26 10C BLACK 320MM
SP1001	070Y132018	SPEAKER	S08F21
△ TH501	DF5EL3R0A0	DEGAUSS ELEMENT	ZPB45BL3R0A
TM101	076N0DW010	TRANSMITTER	RC-DW010
△ TU001	0145K00056	TUNER,VHF-UHF	TECC1040PG32E
△ V801	098Q1404B2	CRT W/DY	A34AGT13X98(L)
X602	100CT3R505	CRYSTAL	HC-49/C

RESISTOR

RC..... CARBON RESISTOR

CAPACITORS

CC..... CERAMIC CAPACITOR
 CE..... ALUMI ELECTROLYTIC CAPACITOR
 CP..... POLYESTER CAPACITOR
 CPP..... POLYPROPYLENE CAPACITOR
 CPL..... PLASTIC CAPACITOR
 CMP..... METAL POLYESTER CAPACITOR
 CMPL..... METAL PLASTIC CAPACITOR
 CMPP..... METAL POLYPROPYLENE CAPACITOR

SERIAL NUMBER CODE

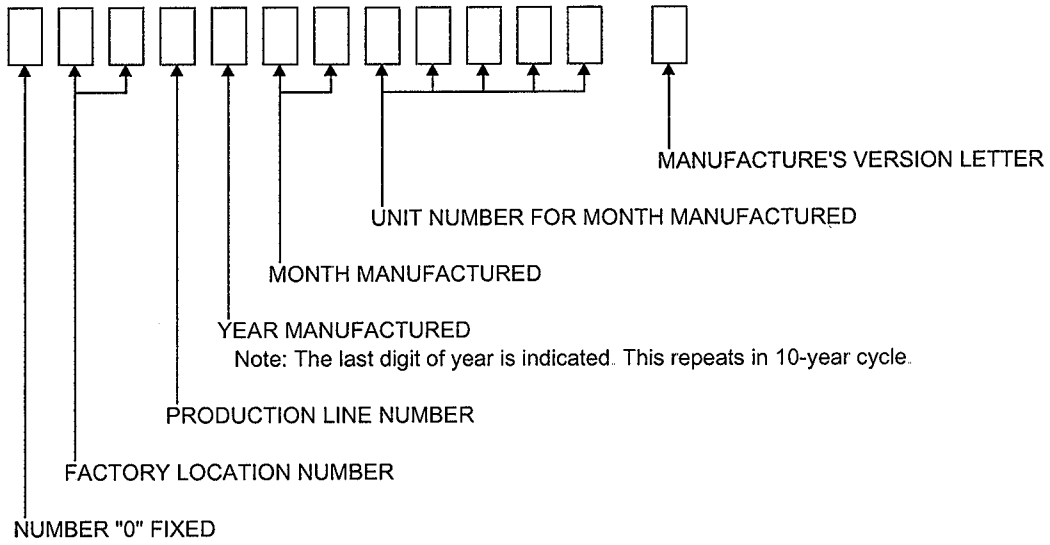



CTGV-4563TCT Series B

SERVICE MANUAL

COLOR TELEVISION RECEIVER

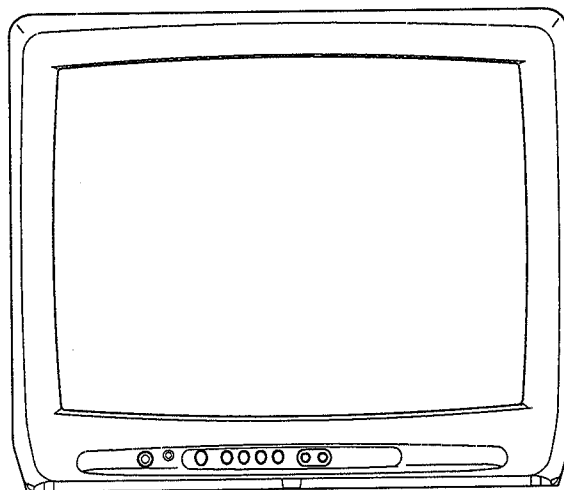

**ORIGINAL
MFR'S VERSION A**



CTGV-4590TCT SERIES B

SERVICE MANUAL

COLOR TELEVISION RECEIVER

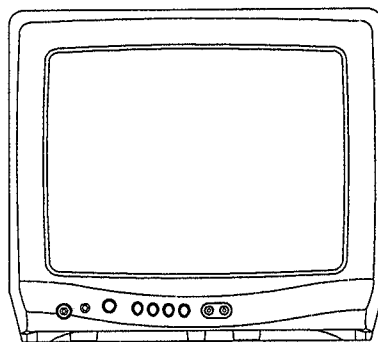

**ORIGINAL
MFR'S VERSION D**

This SUPPLEMENT must be used together SERVICE MANUAL for CTGV-4563TCT SERIES D.
All other test and repair procedures are as shown in the ORIGINAL MANUAL.
Please file this SUPPLEMENT with the ORIGINAL VERSIONS.

ELECTRICAL REPLACEMENT PARTS LIST

REF. NO.	CTGV-4563TCT SERIES B		CTGV-4590TCT SERIES D	
	PART NO.	DESCRIPTION	PART NO.	DESCRIPTION
TM101	076N0DW110	TRANSMITTER RC-DW110	076N0DW100	TRANSMITTER RC-DW100

MECHANICAL REPLACEMENT PARTS LIST

REF. NO.	CTGV-4563TCT SERIES B		CTGV-4590TCT SERIES D	
	PART NO.	DESCRIPTION	PART NO.	DESCRIPTION
101	7A701A260A	FRONT CABI ASS'Y	7A701A390A	FRONT,CABI ASS'Y
101A	701WPJC856	CABINET,FRONT	701WPJC999	CABINET,FRONT
101C	735WPBB266	BUTTON,FRAME	735WPAA953	BUTTON,FRAME
102	702WPAA720	CABINET,BACK	702WPBA202	CABINET,BACK
103	722019A135	SHEET,RATING	722019A142	SHEET,RATING
---	793WCDC186	GIFT,BOX	793WCDC690	GIFT,BOX

SPEC.NO.	M3R0-12V
O/R NO.	K533029

Change of CRT

ELECTRICAL REPLACEMENT PARTS LIST

REF. NO.	MFR'S VERSION A		MFR'S VERSION C	
	PART NO.	DESCRIPTION	PART NO.	DESCRIPTION
△ V801	098Q1404B2	CRT W/DY A34AGT13X98(L)	098Y1404B9	CRT W/DY A34JXV70X53N45

CRT are interchangeable.

SPEC.NO.	M3L1-03C
O/R NO.	K253007

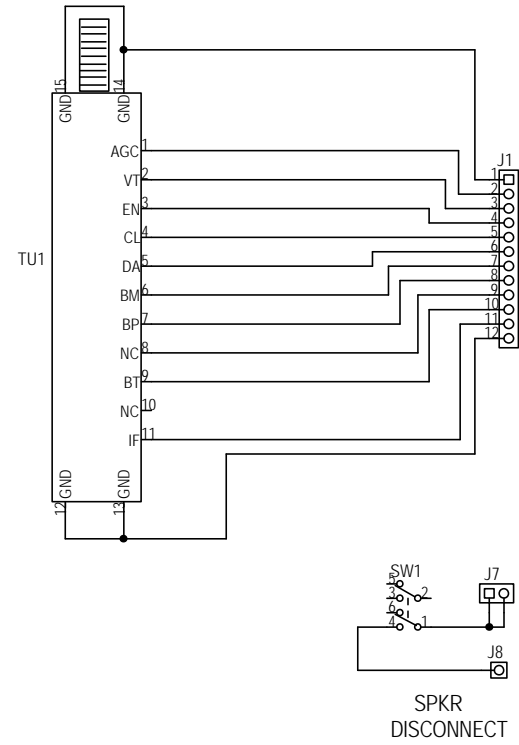
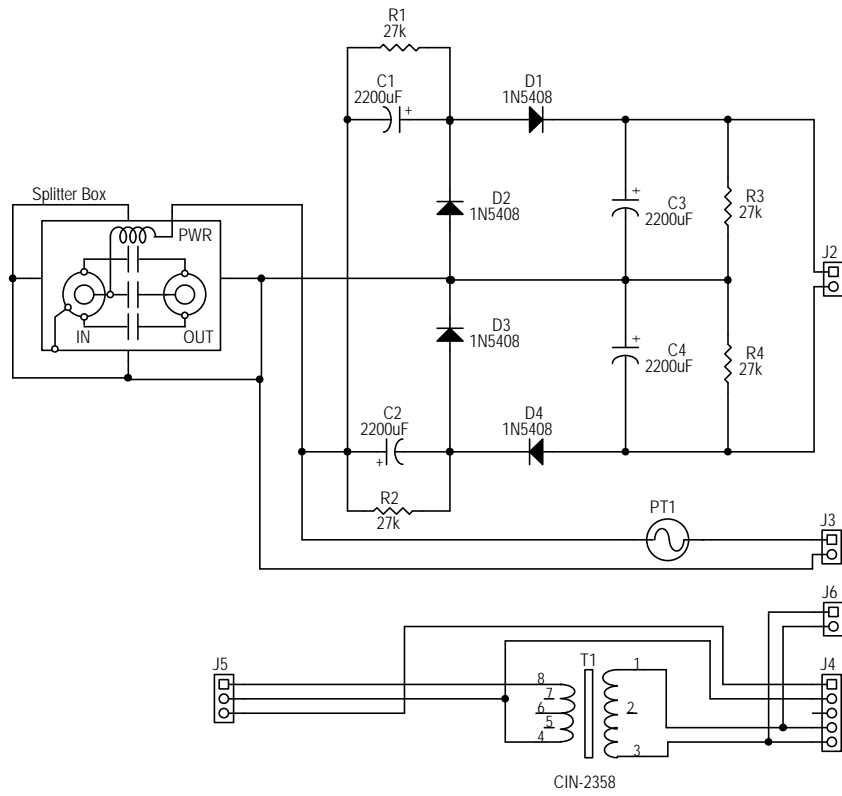

PARTS LIST

C1-4	2200uF, 100V Electrolytic	Panasonic ECO-S2AP222BA	Digikey P6102-ND
R1-4	27K, 1/2W, 5% Carbon Film		Mouser 293-27K
D1-4	1N5408, 3A, 1000V Diode		Mouser 625-1N5408
T1	Audio Isolation XFMR	CinTran CIN-2358	CinTran CIN-2358
J1	.100", 12 Pin Locking Header	Molex 22-23-2121	Digikey WM4210-ND
J2	.156", 2 Pin Locking Header	Molex 26-60-4020	Digikey WM4620-ND
J3	.156", 3 Pin Locking Header	Molex 26-60-4030	Digikey WM4621-ND
J4	.100", 5 Pin Straight Header	Molex 22-03-2051	Digikey WM4003-ND
J5	.100", 3 Pin Locking Header	Molex 22-23-2031	Digikey WM4201-ND
J6,7	.100", 2 Pin Locking Header	Molex 22-23-2021	Digikey WM4200-ND
SB	RF Splitter Box	PDI-1395	PDI-1395
SW1	SPDT ON-ON	C&K 7101SYZBE	Digikey CKN1021-ND
Boot	Vinyl Toggle Cap, White	C&K 8968010000	Digikey CKN1203-ND

PDI Communication Systems claims proprietary right to the material disclosed hereon. This drawing is issued in confidence for servicing information only and may not be reproduced or used to manufacture anything shown hereon without permission from PDI to the user. The information contained hereon is believed accurate, but is not warranted, and is subject to change without notice or obligation. Copyright © 2001 by PDI. All rights reserved.

13" Quadrupler Power Supply	
Rev Draft	ID Part Number PD128-1350
Date: June 12, 2000	Page: 1 of 1

A

B

C

D

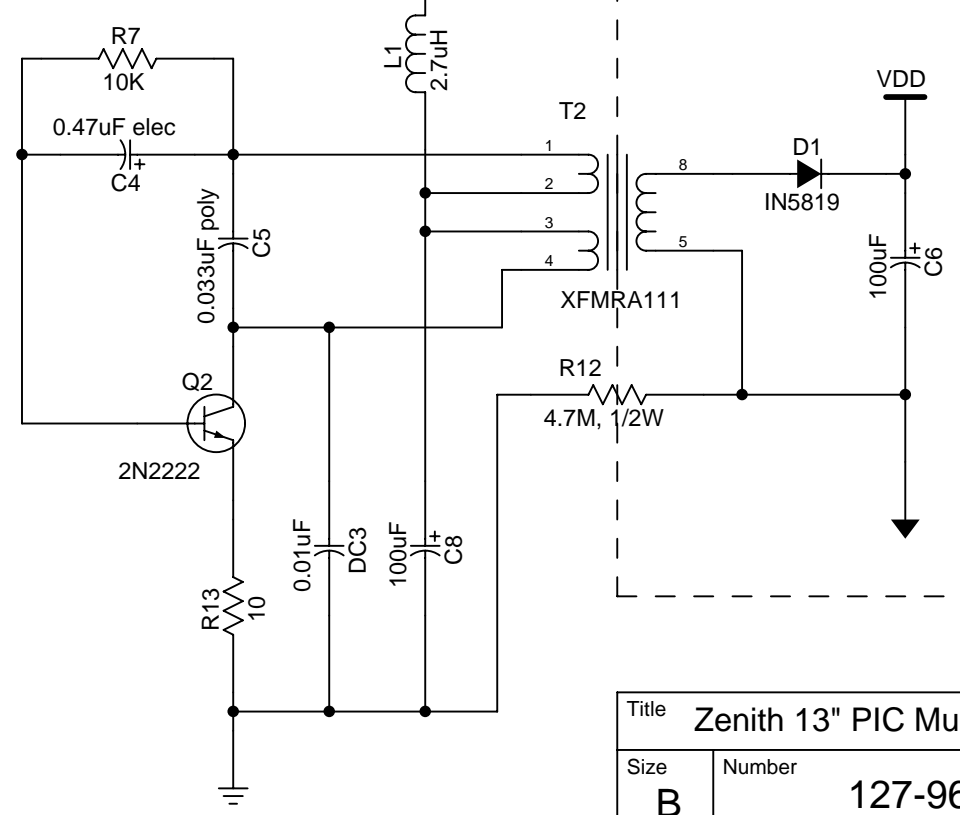
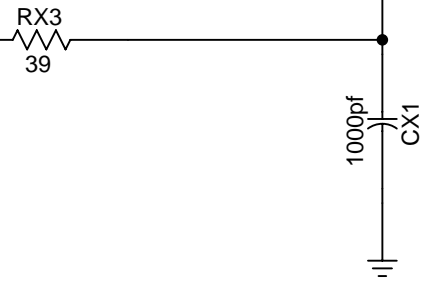
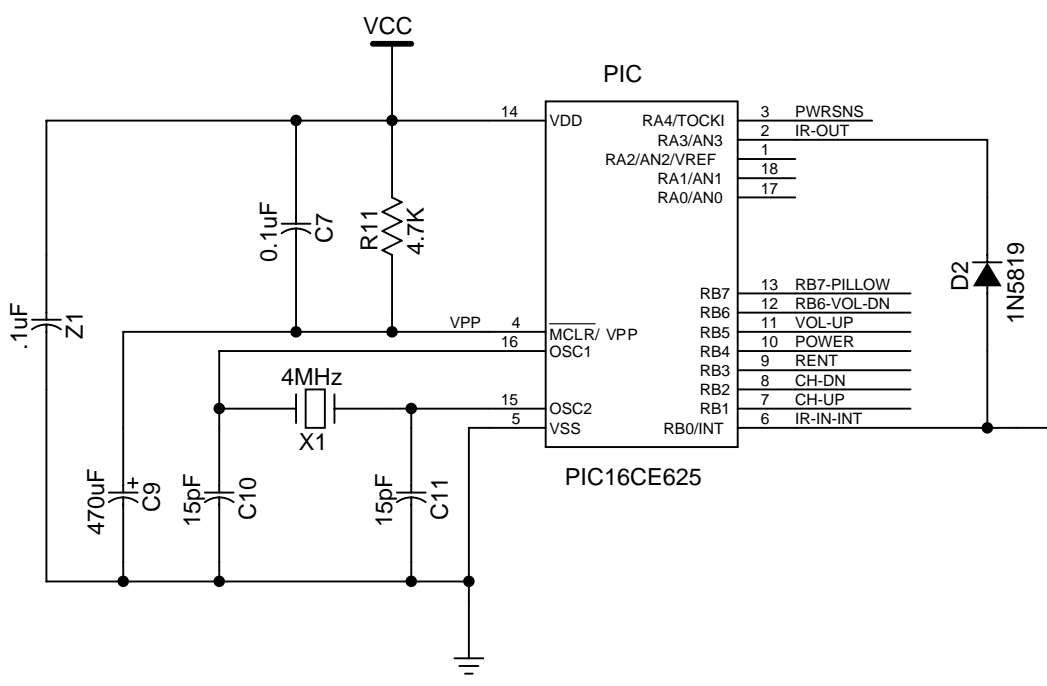
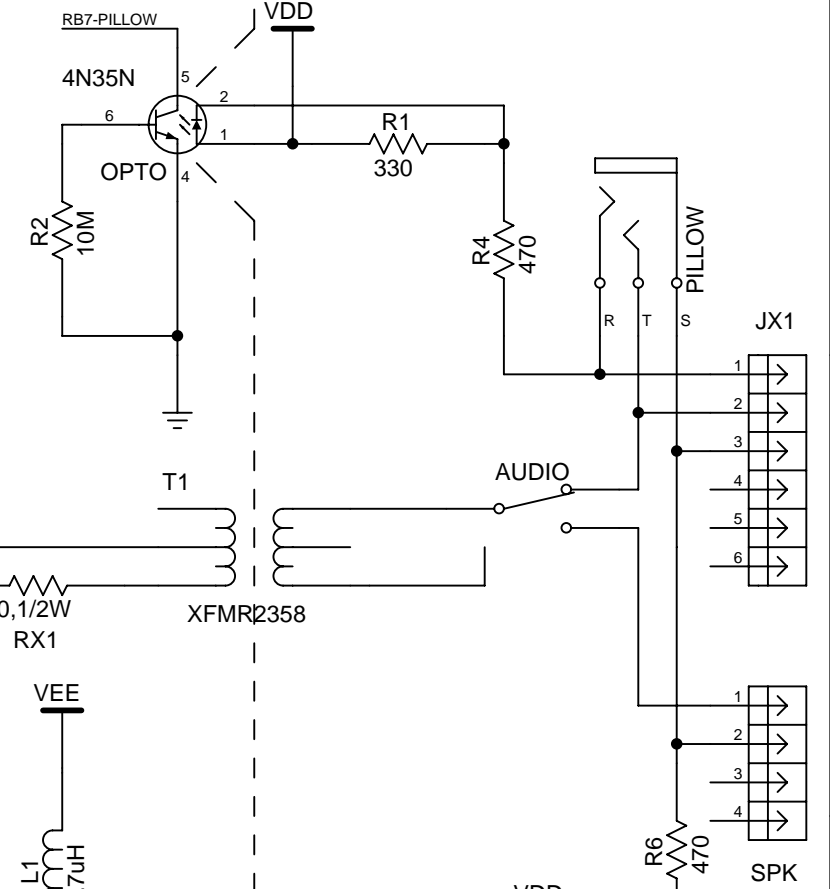
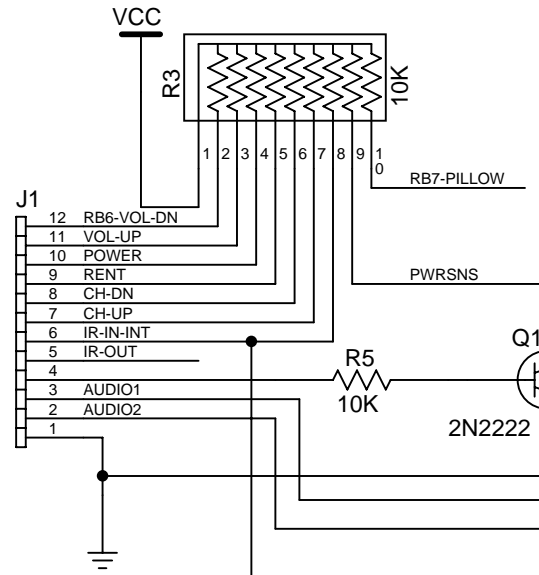
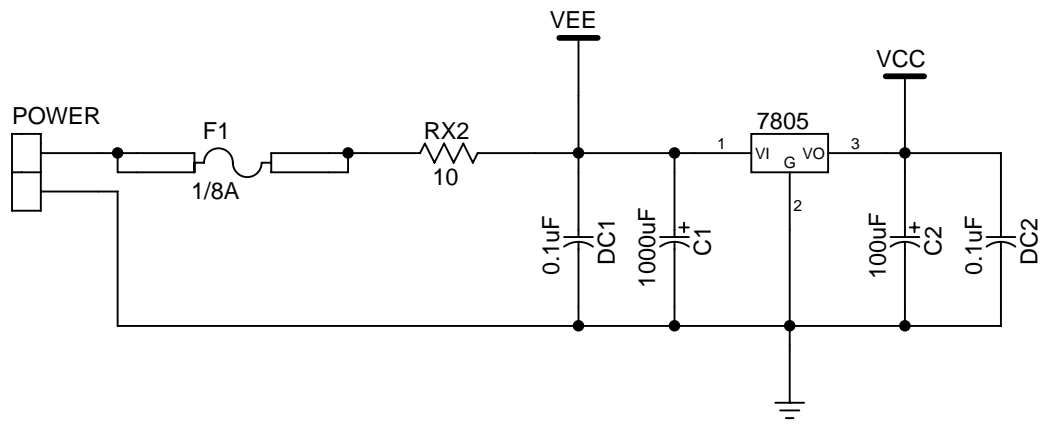

PDI Communication Systems claims proprietary right to the information disclosed herein. This drawing is issued in confidence for servicing information only and may not be used to manufacture anything shown hereon without permission from PDI to the user. The information contained hereon is believed accurate, but is not warranted, and is subject to change without notice or obligation.

material disclosed herein. This drawing is issued in confidence for servicing information only and may not be used to manufacture anything shown hereon without permission from PDI to the user. The information contained hereon is believed accurate, but is not warranted, and is subject to change without notice or obligation.

Copyright 2001 by PDI. All rights reserved.

Title Zenith 13" PIC Multi-Tier		
Size B	Number 127-960D	Rev D
Date Thu Aug 16, 2001	Drawn by NLM	
Filename 127-960D.S01	Sheet 01 of 01	

L-2

A

B

C

D