 PDi Communication Systems, Inc. Your Source for Healthcare and Wellness Infotainment™	MODEL NUMBER: PD168-103	Document Number: PD196-083R4
	Installation for 100mm VESA Compliant Wall Mounts	Page 1 of 2

SCOPE:

TO INSTALL A PD168-103 WALL MOUNT TO AN LED TV. THESE BRACKETS HAVE A STANDARD 100MM VESA PATTERN AND WILL WORK WITH PDI E24LED TV AS WELL AS OTHER SETS THAT HAVE A 100MM VESA MOUNTING PATTERN FOR USE WITH M4 SCREWS.

SAFETY STEPS:

1. ALWAYS WEAR SAFETY GLASSES/GOGGLES TO PREVENT INJURY FROM DEBRIS.
2. FOLLOW THE INSTALLATION /REMOVAL INSTRUCTIONS FOR YOUR EXISTING PRODUCTS.

TOOLS:

1. P1 OR P2 PHILLIPS SCREWDRIVER
2. 1/4" HEX BIT DRIVER
3. SAFETY GLASSES/GOGGLES

PROCEDURE:

STEP 1:

SELECT A LOCATION ON THE WALL APPROXIMATELY 9 INCHES BELOW THE CEILING. POSITION THE PD181-697 (#1) VERTICAL MOUNT CLEVIS AND LOCATE THE TWO MOUNTING HOLES. SECURE THE BRACKET TO THE WALL WITH APPROPRIATE WALL ANCHORS. (MOUNTING HARDWARE IS NOT INCLUDED)

STEP 2:

POSITION THE PD181-596 100MM VESA MOUNTING BRACKET (#2) ON THE LED TV CABINET. ATTACH WITH THE (#4) M4 SCREWS PROVIDED.

PARTS LIST

ITEM	PART NUMBER	DESCRIPTION	QTY
1	PD181-697	VERTICAL MOUNT CLEVIS	1
2	PD181-596	100MM VESA MOUNTING BRACKET	1
3	PDIPPBHSCS103250	10-32 X 1/2 PILFER PROOF SCREW	2
4	PDIPPHMSM4X76	M4-.7 X 6MM PHILLIPS SCREW	4
5	PD219-020	TAMPER RESISTANT HEX BIT	1
6	PD218-001	8" TY-WRAP	2

* DRAWINGS DISPLAY BRACKETS MOUNTED ON A 100MM VESA COMPLIANT TV FOR REFERENCE PURPOSES.

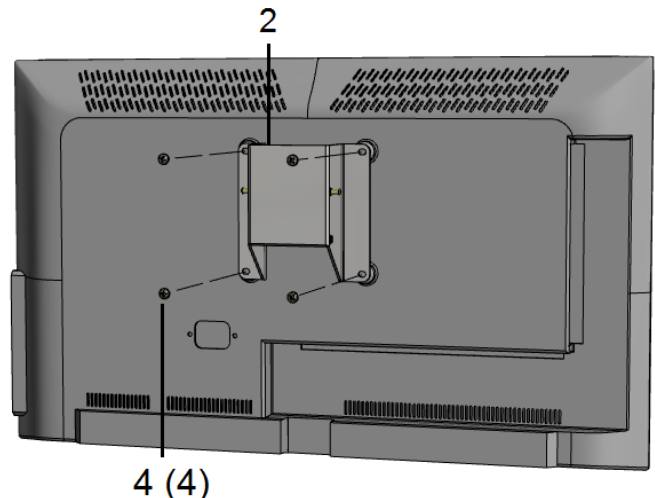
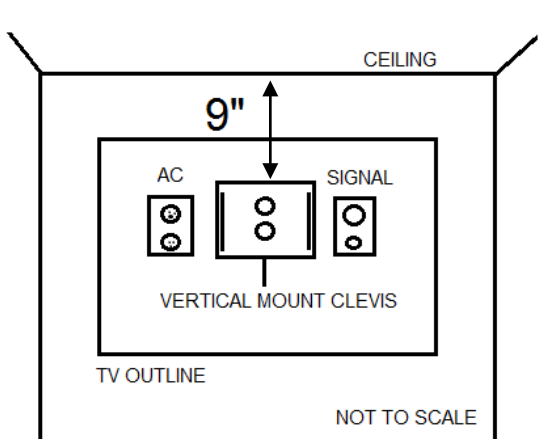

	MODEL NUMBER: PD168-103	Document Number: PD196-083R4
	Installation for 100mm VESA Compliant Wall Mounts	Page 2 of 2

STEP 3:

MATE THE 100MM VESA BRACKET (#2) TO THE VERTICAL MOUNT BRACKET (#1) MAKING SURE THE PIVOT BOLTS ARE RETAINED IN THE "L" SHAPED SLOT. SECURE WITH TWO PILFER SCREWS (#3).

STEP 5:

THE TV'S TILT CAN BE ADJUSTED BY LOOSENING BOTH PILFER SCREWS (#3), ADJUSTING TILT, AND THEN TIGHTENING WITH TAMPER RESISTANT HEX BIT (#5).

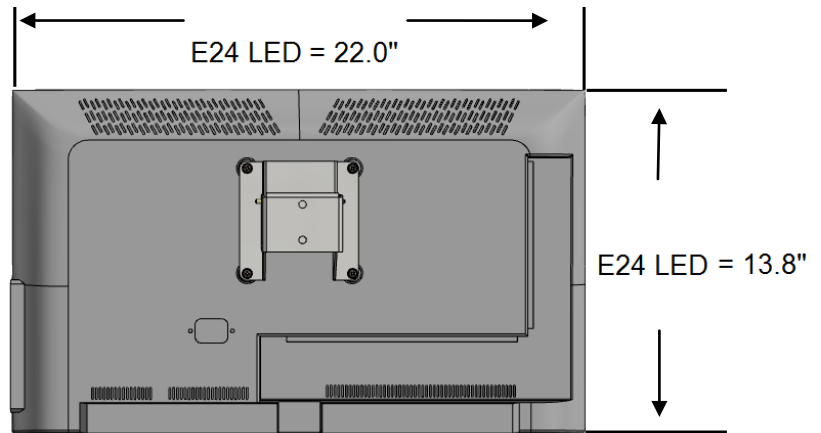
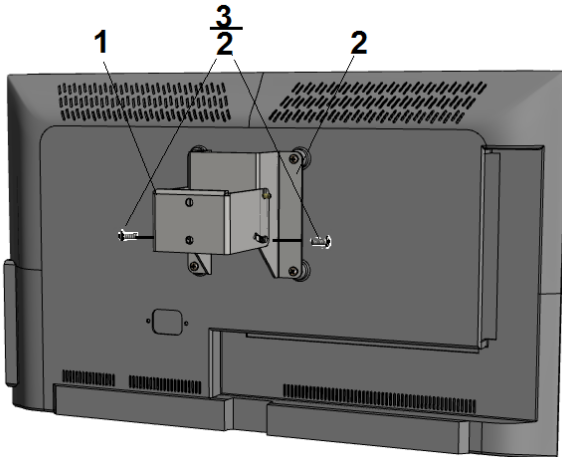

PD181-697

