

	This symbol indicates that dangerous voltage constituting a risk of electric shock is present within this unit.
	This symbol indicates that there are important operating and maintenance instructions in the literature accompanying this unit.

	<b>CAUTION</b> RISK OF ELECTRIC SHOCK, DO NOT OPEN!	
<b>CAUTION: TO REDUCE THE RISK OF ELECTRIC SHOCK, DO NOT REMOVE COVER. NO USER SERVICEABLE PARTS INSIDE. REFER SERVICING TO QUALIFIED SERVICE PERSONNEL</b>		

**THIS INSTALLATION SHOULD BE MADE BY A QUALIFIED SERVICE PERSON AND SHOULD CONFORM TO ALL LOCAL CODES. READ AND FOLLOW THE SAFETY INSTRUCTIONS BEFORE ATTEMPTING THIS INSTALLATION.**

**Note to CATV installer.** This reminder is provided to call the CATV system installer's attention to Article 820-40 of the NEC that provides guidelines for proper grounding and, in particular, specifies that the cable ground shall be connected to the grounding system of the building, as close to the point of cable entry into the room as practical.

 **WARNING: OXYGEN ENVIRONMENT** DO NOT use in an oxygen tent or oxygen chamber. Such use may cause a fire hazard.

**WARNING:** To avoid the hazards of fire or electric shock, DO NOT expose this TV to rain or moisture.



**DANGER: ARM RECOIL HAZARD** The safety brake pin must remain in the SAFETY BRAKE PIN HOLE whenever the television set is removed from the arm or when the arm is removed from the wall bracket to prevent the arm from springing open.

## INSTALL ARM & TV

Contact PDI for complete list of approved TV model numbers for which this arm can be used.



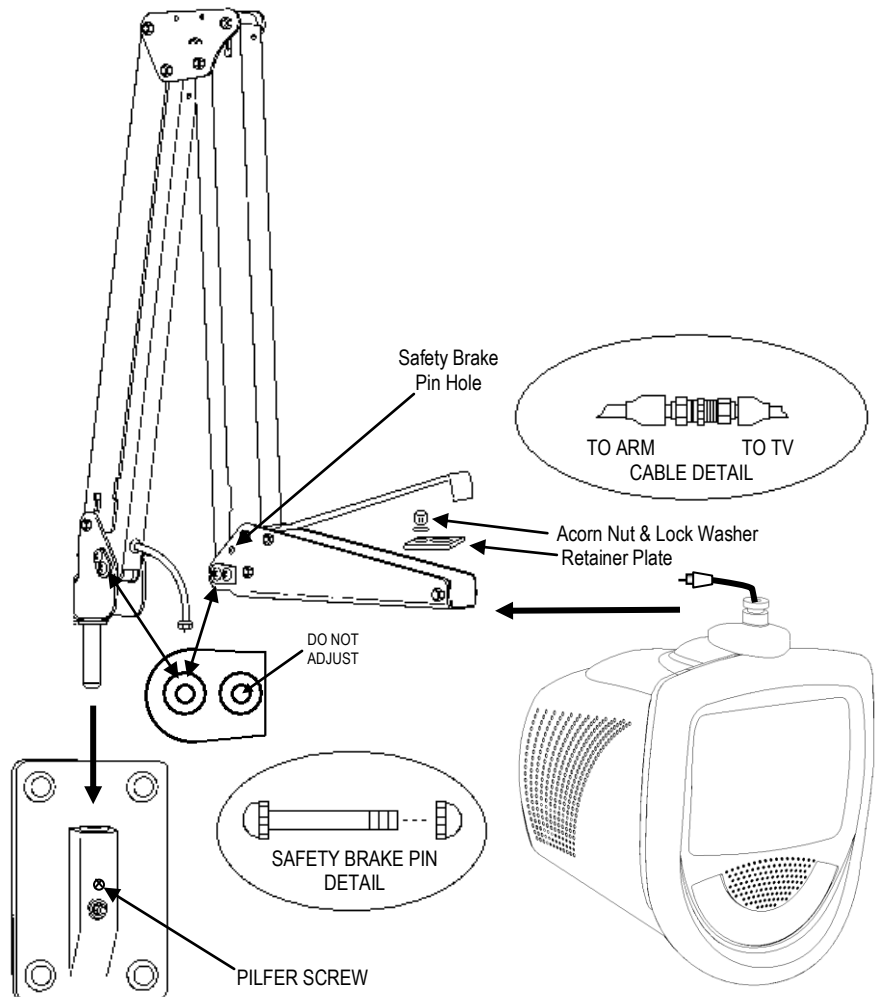

- Place the arm's base pin into the wall bracket. The base pin should seat snug in the wall bracket.
- Tighten the wall bracket pilfer screw if so equipped.
- Open the nose cover and remove the retainer plate.
- Insert the TV swivel completely in the clevis (slot). Reinstall the retainer plate. Replace the lock washer and nut, and tighten with a wrench.
- The cable from the arm should be joined with the television cable, wrench tightened, and the connection covered by sliding the plastic boot sections into mating position.
- Remove the safety brake pin from the parking brake hole. Close the arm's nose cover in the front and line up the cover pin holes. Secure the nose cover using the safety brake pin and nut.
- Connect the coaxial cable at the base of the arm to the wall bracket "F" fitting. Wrench tighten.
- Cycle the arm once or twice to check for free movement – if stiff, a slight loosening of the single friction screw will free the movement. **DO NOT LOOSEN MORE THAN 1/16 TURN.**
- Power the TV and verify correct operation. Refer to the instructions packed with the TV for programming and operation details.

Plastic covers may also be installed on the arm. Please refer to the instructions packed with the covers for installation directions.



## IMPORTANT SAFETY INSTRUCTIONS

Read and follow all of the safety and operating instructions before using this suspension arm. Keep these instructions for future reference.

	<p><b>WARNING:</b> This arm contains internal springs under tension. AN ARM RECOIL ACCIDENT HAZARD IS POSSIBLE. FOLLOW ALL SAFETY INSTRUCTIONS AT ALL TIMES.</p>		<p><b>CAUTION:</b> Keep the SAFETY BRAKE PIN in place UNTIL arm is on wall mount and TV is in place. THEN, remove and use to secure cover plate.</p>
	<p><b>CAUTION:</b> ALWAYS put SAFETY BRAKE PIN in place before removing TV arm, or arm from wall.</p>		<p>To prevent fire or shock hazard, DO NOT EXPOSE this apparatus to rain or moisture.</p>

Apparatus shall not be exposed to dripping or splashing and no objects filled with liquids, such as vases, shall be placed on the apparatus. Unplug this unit from the wall outlet before cleaning. Do not use liquid cleaners or aerosol cleaners. Use a damp cloth for cleaning. This unit REQUIRES periodic maintenance. Refer to the maintenance section for instructions.

1. Read these instructions.
2. Keep these instructions.
3. Heed all warnings.
4. Follow all instructions.
5. Do not use this apparatus near water.
6. Clean only with dry cloth.
7. Do not block any ventilation openings. Install in accordance with the manufacturer's instructions.
8. Do not install near any heat source such as radiators, heat registers, stove, or other apparatus (including amplifiers) that produce heat.
9. Do not defeat the safety purpose of the polarized or grounding-type plug. A polarized plug has two blades with one wider than the other. A grounding type plug has two blades and a third grounding prong. The wide blade or the third prongs are provided for your safety. If the provided plug does not fit into your outlet, consult an electrician for replacement of the obsolete outlet.
10. Protect the power cord from being walked on or pinched particularly at plugs, convenience receptacles, and the point where they exit from the apparatus.
11. Only use attachments/accessories specified by the manufacturer.
12. Use only with the cart, stand, tripod, bracket or table specified by the manufacturer, or sold with the apparatus. When a cart is used, use caution when moving the cart/apparatus combination to avoid injury from tip-over.
 
13. Unplug this apparatus during lightning storms or when unused for long period of time.
14. Refer all servicing to qualified service personnel. Servicing is required when the apparatus has been damaged in any way, such as power-supply cord or plug is damaged, liquid has been spilled or objects have fallen into the apparatus, the apparatus has been exposed to rain or moisture, does not operate normally, or has been dropped.

## ARM MAINTENANCE

Very little maintenance should be required for your PDI Arm to give years of trouble free service if the following lubrication and inspection procedures are followed.

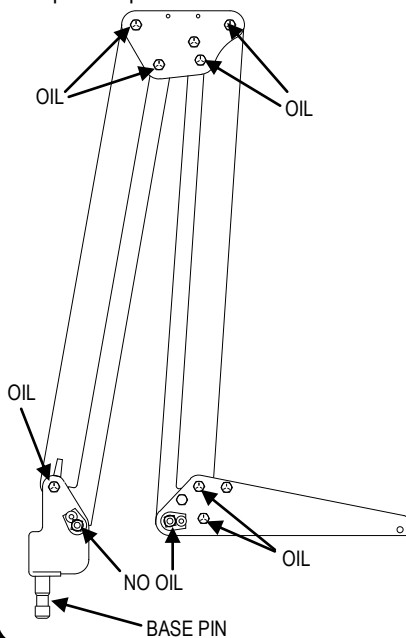

1. **INSPECTION** – Occasionally check the base pin for any evidence of bending or distortion due to a patient using the ARM for assistance in getting in or out of bed or any other misuse. If the ARM is not mounted with the base pin absolutely vertical, it will have a tendency to drift and will not properly counter balance the television. Be certain that the wall the arm is mounted to is vertical. If the ARM shows any tendency to sag under the weight of the TV, it may be necessary to adjust the spring tension of the front or back sections. (Refer to Maintenance Manual)
2. **SPRING ADJUSTMENT** – See adjustment procedure in the full maintenance manual for your model arm.
3. **LUBRICATION** - At least once a year a drop of light machine oil should be put on each pivot point in the nose, elbow, and base. DO NOT PUT OIL ON THE FRICTION DAMPER PADS!
4. **REPLACEMENT OF COAX CABLE** – See cable replacement procedure in the full maintenance manual for your arm.
5. **TORQUE ADJUSTMENT OF PIVOT SCREWS** – All screws in the ARM are tightened securely, and Loctite, at the factory and do not require specific checks with a torque wrench. IF THE THREADS ARE STRIPPED IN THE NOSE, ELBOW, OR BASE, THAT PART NEEDS REPLACEMENT – DISCONTINUE USE IMMEDIATELY.