

# 3,500LTR CORRUGATED POLY WATER TANK

## INSTALLATION:

TANKS ARE TO BE INSTALLED ON A WELL COMPACTED, LEVELLED EARTH PAD, FREE FROM SHARP OR LOCALISED HARD STONES/OBJECTS THAT COULD DAMAGE THE TANK BASE. THE ROOF OF THIS TANK IS INTENDED ONLY TO COVER AND IS NOT TO BE TRAFFICABLE ROOF.

## MATERIAL:

LLDPE MATERIAL DESIGNED SPECIFICALLY FOR ROTATIONAL MOULDING APPLICATIONS DELIVERING A HIGH ESCR, CHEMICAL RESISTANCE, STIFFNESS AND TOUGHNESS WHICH IS UV STABILISED TO PROVIDE PROLONGED OUTDOOR PROTECTION IN HARSH AUSTRALIAN CONDITIONS.

## STANDARDS:

ALL TANKS BY COERCO ARE MANUFACTURED IN GUIDANCE WITH AUST STANDARD AS4766 AND ARE STRUCTURALLY ENGINEERED TO CONFORM TO CYCLONIC AREAS AND STRESS ANALYSIS TESTING REQUIREMENTS.

## DIMENSIONS:

DIMENSIONS MAY VARY SLIGHTLY DUE TO THE SHRINKAGE NATURE OF POLYETHYLENE.

**NOTE:** THIS DRAWING DETAILS COERCO'S STANDARD WATER TANK FITOUT.

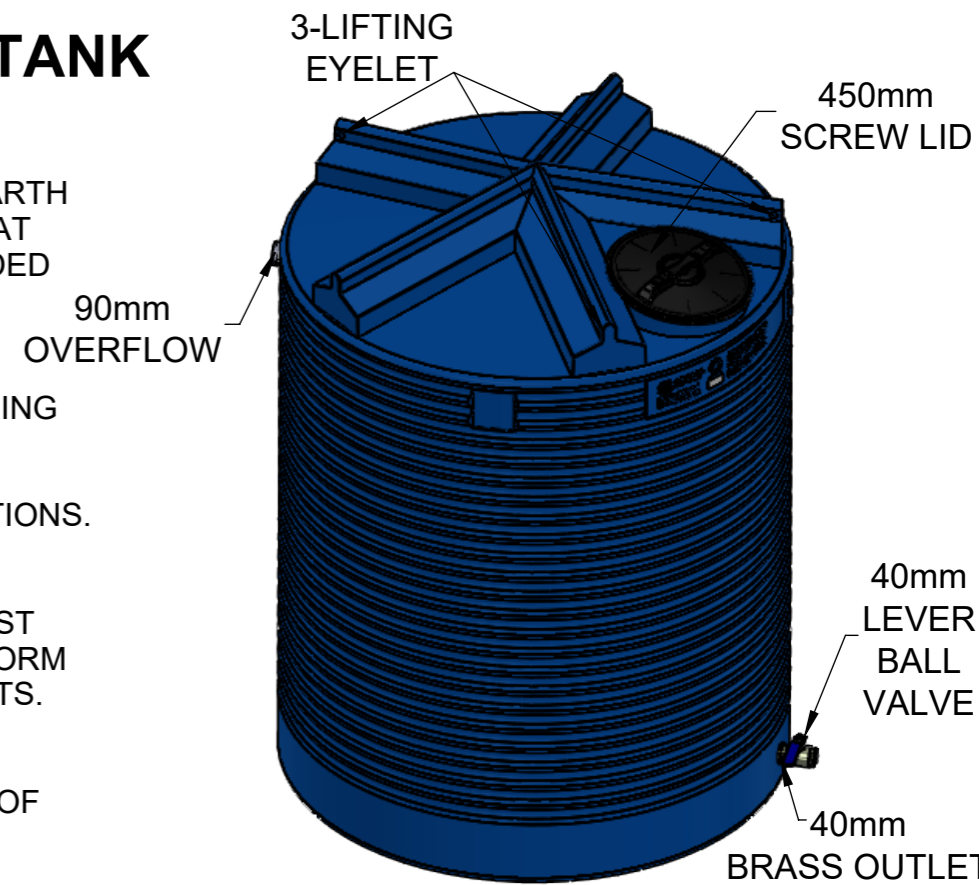
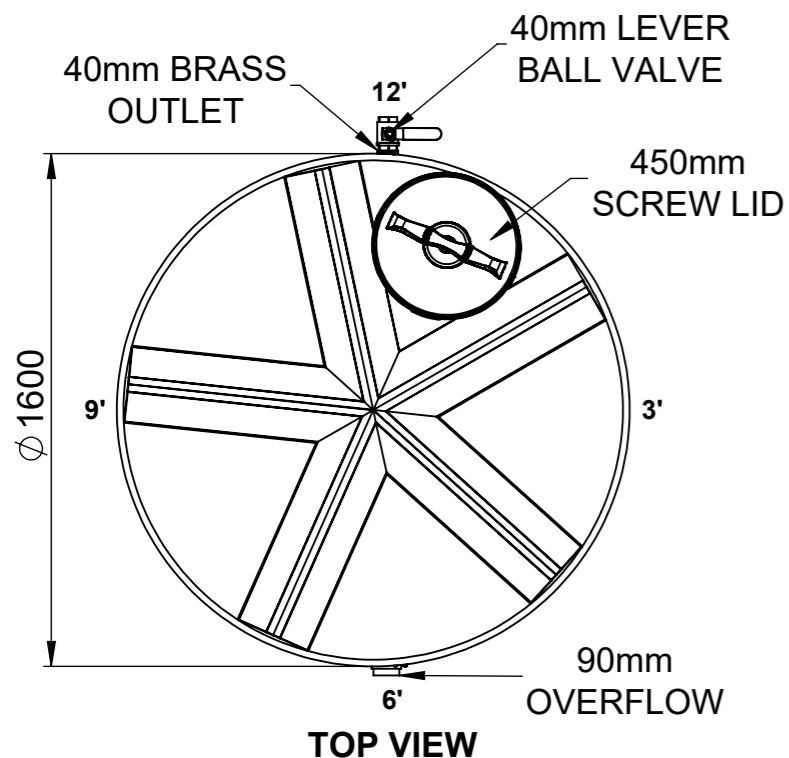

**CERTIFICATION** RSA REF: 19-0081  
 The structure shown on this drawing has been approved by a Chartered Professional Engineer in accordance with the structural requirements of the Building Code of Australia.  
 Signed: *Robin Saller* Date: 5/03/2019  
 Robin Saller BEng(Hons) FIEAust CPEng NER RPEQ  
 RSA Pty Ltd | Unit 6, 9 Playle Street, Myaree WA 6154  
 T: +61 08 9317 3331 | E: info@rsaeng.com.au

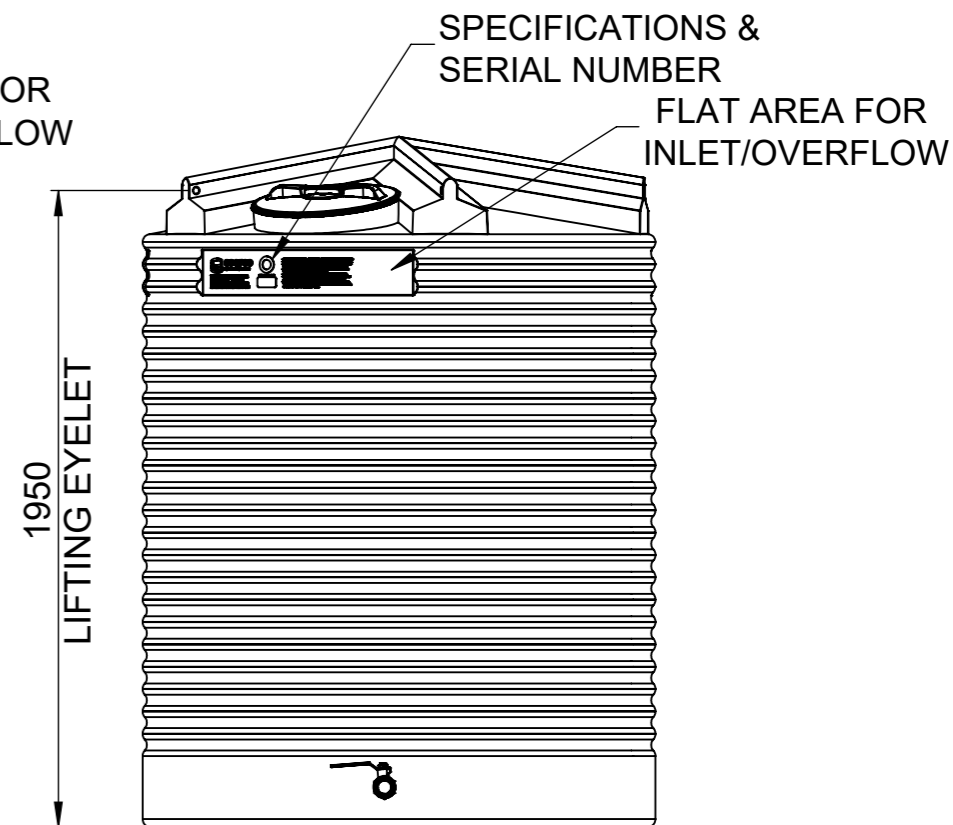
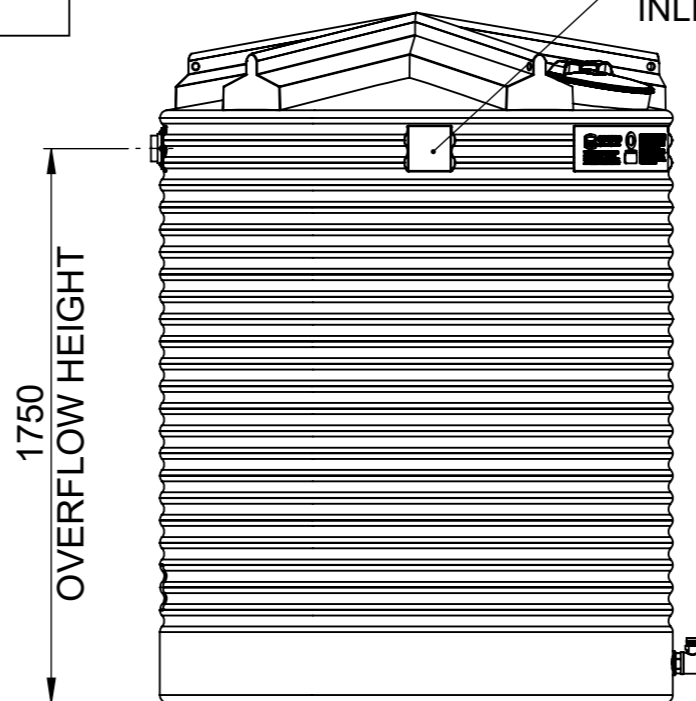
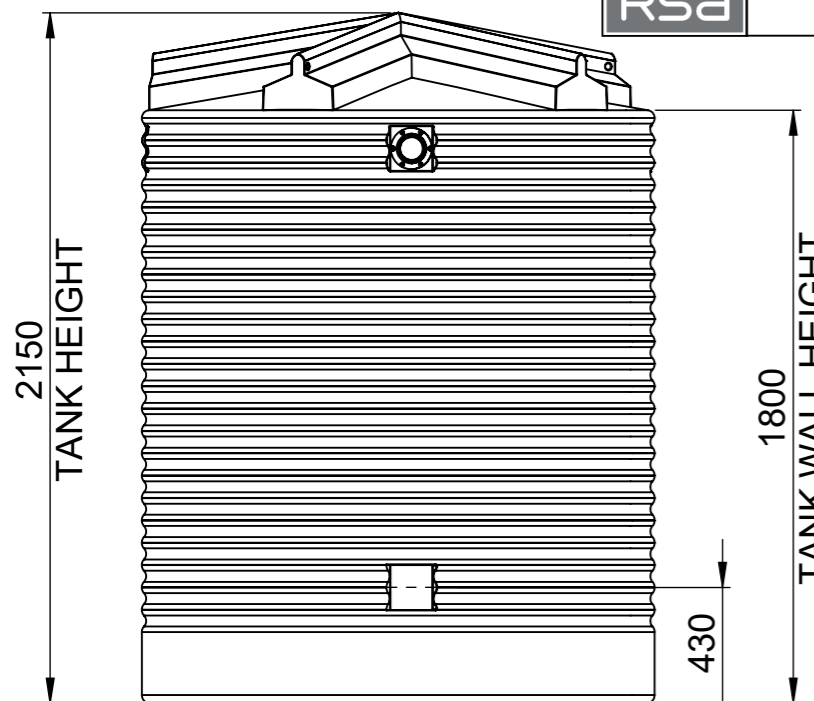

6 O'CLOCK VIEW

3 O'CLOCK VIEW

12 O'CLOCK VIEW



DATE	18/02/2019
PRODUCT	3,500LTR POLY WATER STORAGE TANK
PRODUCT CODE	RT3500
DRAWING No	C-RT3500-001

MATERIAL	LOW DENSITY POLYETHYLENE
SURFACE FINISH	POLISHED
WALL THICKNESS	
SCALE	NOT TO SCALE

REV	BY	DATE	DESCRIPTION
0	GT	18/02/2019	ORIGINAL CAD DRAWING ISSUED

SHEET 1 OF 1
CHKD
APVD
SHEET SIZE <b>A3</b>

© THIS DRAWING IS THE COPYRIGHT OF COERCO. IT CANNOT BE COPIED IN PART OR FULL WITHOUT THE WRITTEN PERMISSION OF COERCO