

CERTIFICATION RSA REF: 19-0326
 The structure shown on this drawing has been approved by a Chartered Professional Engineer in accordance with the structural requirements of the Building Code of Australia.

Signed: *[Signature]* Date: 9/07/2019
 Robin Salter (Engineer) FIE Aust CP Eng NER RPEQ
 RSA Pty Ltd | Unit 6, 9 Playle Street, Myaroo WA 6154
 T: +61 08 9317 3331 | E: info@rsawg.com.au



4,500LTR CORRUGATED INDUSTRIAL TANK

INSTALLATION:
 TANKS ARE TO BE INSTALLED ON A WELL COMPACTED, LEVELLED EARTH PAD, FREE FROM SHARP OR LOCALISED HARD STONES/OBJECTS THAT COULD DAMAGE THE TANK BASE. THE ROOF OF THIS TANK IS INTENDED ONLY TO COVER AND IS NOT TO BE TRAFFICABLE ROOF.

MATERIAL:
 LLDPE MATERIAL DESIGNED SPECIFICALLY FOR ROTATIONAL MOULDING APPLICATIONS DELIVERING A HIGH ESCR, CHEMICAL RESISTANCE, STIFFNESS AND TOUGHNESS WHICH IS UV STABILISED TO PROVIDE PROLONGED OUTDOOR PROTECTION IN HARSH AUSTRALIAN CONDITIONS.

STANDARDS:
 ALL TANKS BY COERCO ARE MANUFACTURED IN GUIDANCE WITH AUST STANDARD AS4766 AND ARE STRUCTURALLY ENGINEERED TO CONFORM TO CYCLONIC AREAS AND STRESS ANALYSIS TESTING REQUIREMENTS.

DIMENSIONS:
 DIMENSIONS MAY VARY SLIGHTLY DUE TO THE SHRINKAGE NATURE OF POLYETHYLENE.

NOTE: THIS DRAWING DETAILS COERCO'S **STANDARD** INDUSTRIAL TANK. ADDITIONAL FITTINGS & ACCESSORIES AVAILABLE. TYPE & LOCATION/S TO BE SPECIFIED AT TIME OF ORDER. TANK AVAILABLE TO ACCOMODATE LIQUIDS OF SPECIFIC GRAVITY UP TO 2.

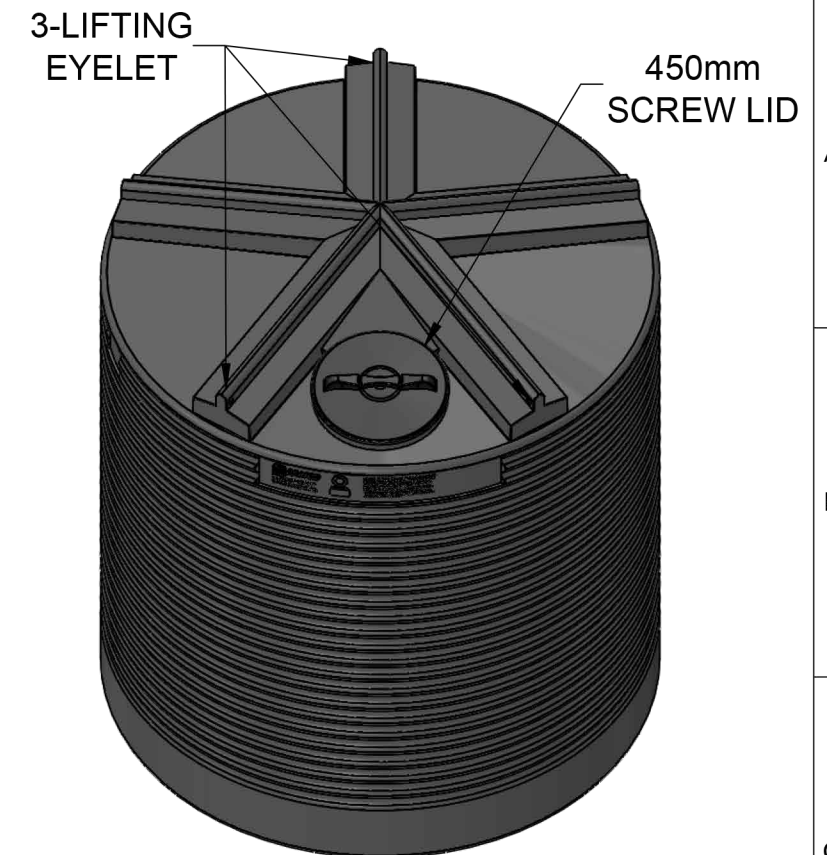

PERSPECTIVE VIEW

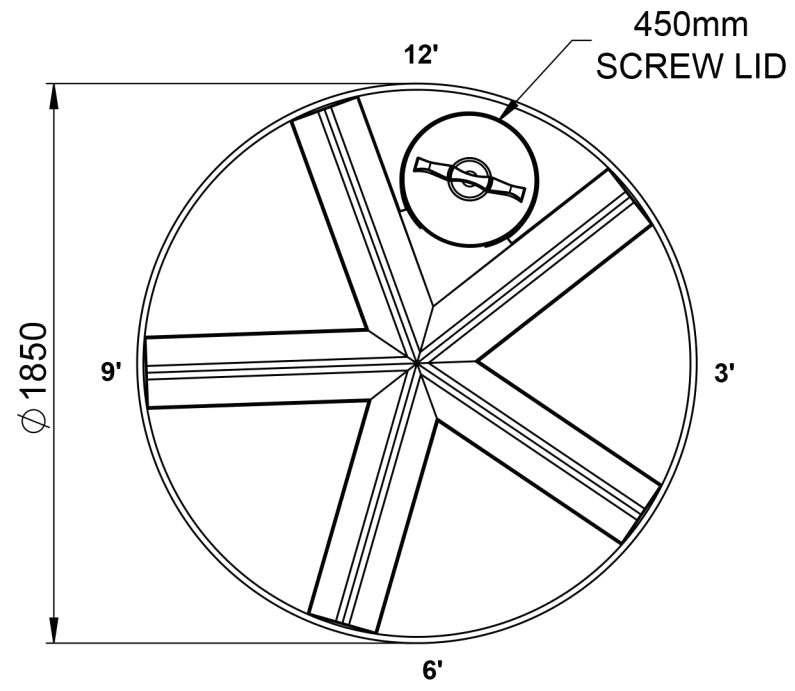

TOP VIEW

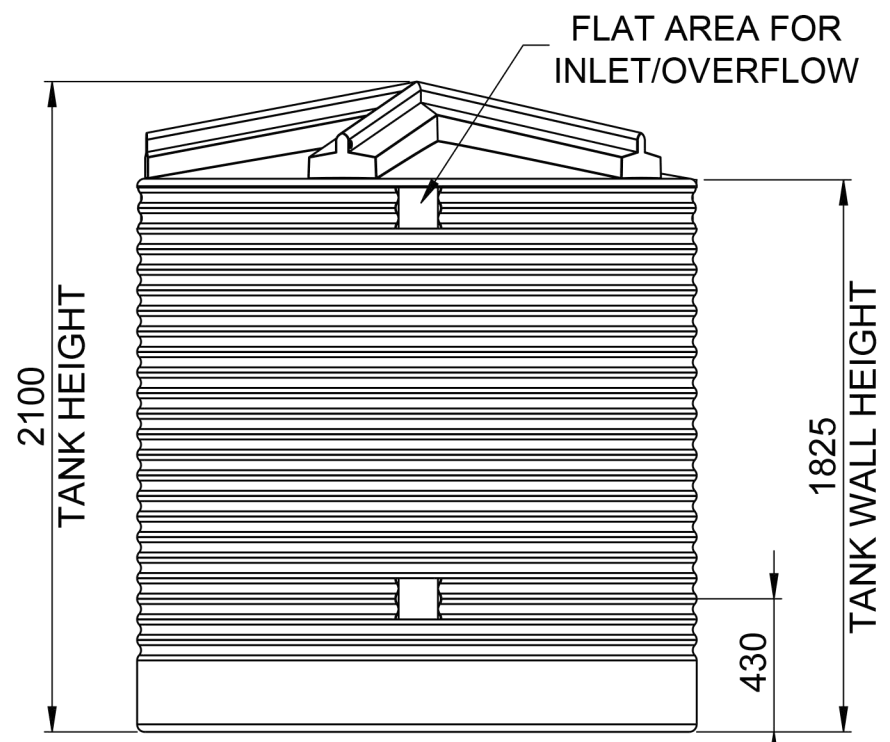

6 O'CLOCK VIEW

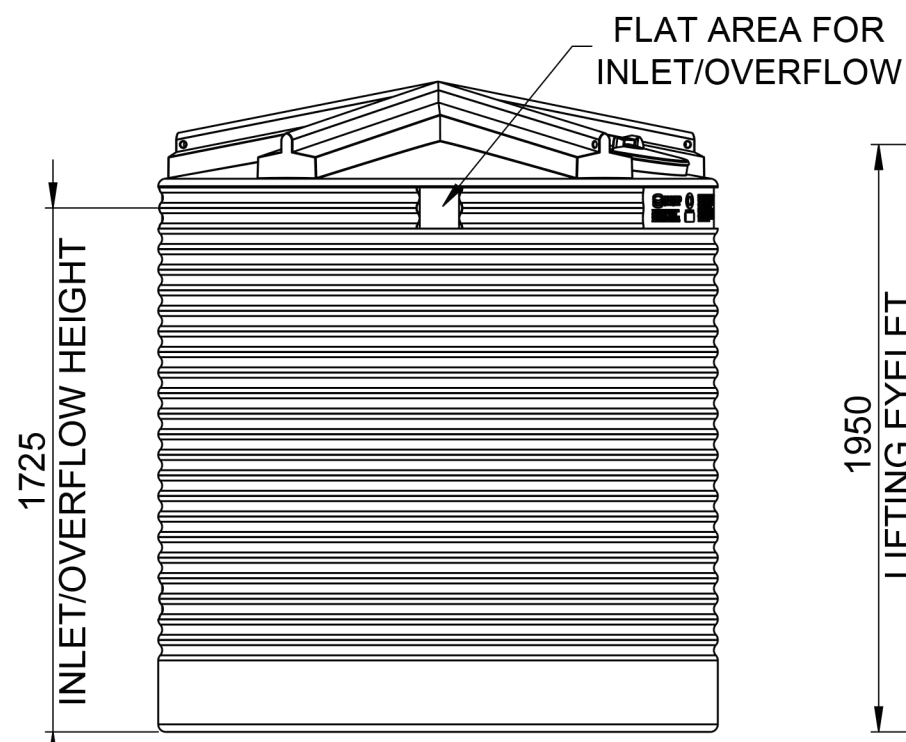
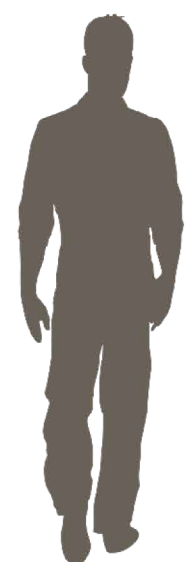

3 O'CLOCK VIEW

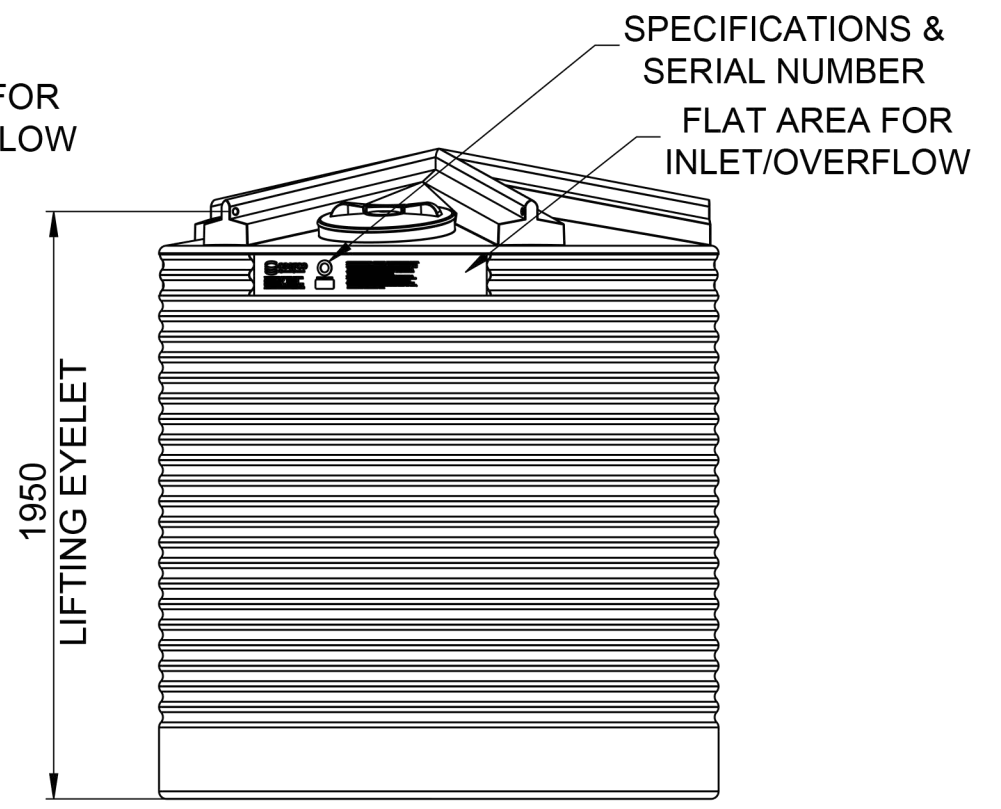

12 O'CLOCK VIEW



DATE	27/06/2019	MATERIAL	LOW DENSITY POLYETHYLENE
PRODUCT	4,500LTR CORRUGATED INDUSTRIAL TANK	SURFACE FINISH	POLISHED
PRODUCT CODE	IT4500	WALL THICKNESS	
DRAWING No	C-IT4500-001	SCALE	NOT TO SCALE

REV	BY	DATE	DESCRIPTION
0	GT	27/06/2019	ORIGINAL CAD DRAWING ISSUED

SHEET 1 OF 1
CHKD
APVD
SHEET SIZE A3

© THIS DRAWING IS THE COPYRIGHT OF COERCO. IT CANNOT BE COPIED IN PART OR FULL WITHOUT THE WRITTEN PERMISSION OF COERCO