

GET IT WE GET IT



SANI MARC

WE GET SANITATION LIKE NO ONE ELSE.

Sani Marc is the Canadian leader in sanitation and maintenance programs. With operations from coast to coast, we offer a wide range of high-quality products to help you get the most out of your sanitation and maintenance programs.



SANI MARC

WE GET POWER AND EFFICIENCY.

At Sani Marc you can get all the customized cleaning equipment you need, including the best autoscrubbers, vacuums and sanitation products on the market.



* Products may vary from visuals display in the brochure .

SANI MARC POWERED BY COMAC

WE GET THE LEADERS.

Sani Marc is proud to announce an exclusive partnership with Comac, one of the European leaders in the production of industrial cleaning machines. Comac boasts a wide range of robust and easy-to-use products. Thanks to this new partnership, our Canadian customers can now choose from an expanded selection of the most advanced machines on the market.

AVAILABLE IN 11" CLEANING
WIDTH

FEATURES

- Always charged and ready-to-use lithium-ion Technology battery
 - Squeegee rubber blade ensures outstanding drying performance, even when cleaning oily liquids
 - Aluminum frame and brush head with anti-corrosion treatment
-



AW-211 B

PORTABLE AUTOSCRUBBER

This machine scrubs and dries in a single pass whenever and wherever. Lightweight and compact, it is easy to use and boasts extraordinary comfort and safety. The floor is dry and safe to walk on in just a few seconds.



AVAILABLE WITH A 20", 22"
AND 26" CLEANING WIDTH,
20" CYLINDRICAL BRUSHES
OR 20" ORBITAL PAD

FEATURES

- Intuitive drive, with only a few easy-to-use controls
- Compact size ideal for many industries
- Fully accessible components for easy maintenance
- Energy-efficient silent operation, thanks to Eco device (66 dBA)

AW-220 series

WALK-BEHIND
AUTOSCRUBBER

Offers high performance for both maintenance and heavy duty cleaning. This autoscrubber stands out for its reliable and durable design. Innovations include a pressure die-cast aluminum squeegee mount, machine frame and brush head. Easy to use and manoeuvre.



AVAILABLE IN 22" CLEANING
WIDTH

FEATURES

- Light and smooth steering for easy, minimal-effort manoeuvring in high-traffic or narrow areas
- Ergonomic steering wheel with controls and display to make driving intuitive and safer,
- SAFETY BRAKE - Automatic stop when the pedal is released

AR-222 B

MICRO RIDE-ON
AUTOSCRUBBER

Silent and compact, this machine is the same size as a walk-behind model but more efficient. Its size increases productivity and reduces maintenance costs. This micro autoscrubber is extremely convenient, comfortable, safe and user-friendly.

AVAILABLE IN 26", 30" AND 34" CLEANING WIDTH AND 28" CYLINDRICAL BRUSHES

FEATURES

- Eco device guarantees a very low acoustic pressure level
 - Easy rubber replacement without tools
 - Automatic squeegee uncoupling when accidentally impacted
-



AR-230 series

RIDE-ON AUTOSCRUBBER

Capable of cleaning over 39,400 sq. ft. per hour, reducing cleaning costs. Runs up to 4 hours non-stop. No operator training required thanks to the "working program selector" that comes standard. The Eco device guarantees a very low acoustic pressure level, allowing it to perform in highly noise-sensitive environments.



AR-340 series

RIDE-ON AUTOSCRUBBER

Cleans wide commercial surfaces over 59,000 sq. ft. per hour. Its robust design ensures excellent performance, even for deep cleaning hard floors in warehouses and logistics centres, or finer surfaces such as in shopping malls. Offers comfort and complete control over the machine for the end-user.

AVAILABLE IN 34" AND 40" CLEANING WIDTH AND 36" CYLINDRICAL BRUSHES

FEATURES

- Working program selector lets you set the machine for transfer, drying, scrubbing or scrubbing and drying simultaneously
 - 3 different working speeds and brush pressure levels
 - The vacuum motor is isolated inside a double wall chamber, reducing the noise level
-



AVAILABLE IN 17" WORKING WIDTH AND WITH AN OPTIONAL SPRAY KIT

FEATURES

- Roto-orbital action of the disc maximizes efficacy on any type of floors, including carpet
 - Various pad holders let you properly set the polisher according to the type of work to be done
-

PW-317

SINGLE DISC POLISHER

Single disc polisher recommended for heavy-duty jobs. The orbital movement enhances the performance of a regular single disc machine. Takes less time to wash, degrease, strip and crystalize floors. Uses less water, detergent and energy than a traditional polisher. Simple to use. Requires no specific training.



AVAILABLE IN 10-L AND 15-L FORMATS

FEATURES

- "ON" switch can also be pedal-operated
 - Easy access to the recovery bag
 - Rubber side impact protection
 - 15-L offers more functionalities
-

VC-215 EX

DRY CANISTER VACUUM

High-performance vacuum cleaner, powerful yet delicate for discretion and functionality. Includes several unique useful features and a serial filtration system that releases clean air back into the environment.

TASKI
TASKI
TASKI
TASKI
TASKI
TASKI
TASKI
TASKI

WE GET RELIABILITY.

The strong reputation of Taski equipment speaks for itself. The brand boasts a proven track record in healthcare and educational facilities where standards are high. Efficient and environmentally friendly, Taski machines clean surfaces with 40% less water with their IntelliFlow™ system and require less energy and chemicals.



AVAILABLE IN 26" CLEANING
WIDTH

FEATURES

- Immediately dry floors
 - With simple and intuitive controls, the machine reduces operator fatigue and minimizes training
 - Brushes perfectly follow the floor profile for outstanding soil removal
-

Swingo 1650 B

WALK-BEHIND
AUTOSCRUBBER

This machine's 23 gallon (85 l) tank and highly efficient IntelliFlow™ reduce water consumption significantly. Cleans up to 27,000 ft² without time-consuming tank filling stops. Reduced energy consumption and high capacity batteries allow a run time of more than four hours before recharging.



AVAILABLE IN 20" CLEANING WIDTH

FEATURES

- Brush follows the floor profile and delivers nearly even pressure allocation along the full working width, which leads to excellent soil removal
 - Squeegee enables excellent water pick-up on the floor
 - All components needing frequent maintenance are colour-coded in yellow and can be removed easily without tools
-

Swingo 855B

BATTERY-POWERED AUTOSCRUBBER

This walk-behind autoscrubber is very easy to handle and offers maximum agility for use in confined areas. The dual-axle system allows for turning the machine literally on the spot, which leads to excellent manoeuvrability in tight areas. The 11-gallon (40-L.) tank volume reduces need for re-filling.



AVAILABLE IN 17" CLEANING WIDTH

FEATURES

- Tried and tested three-wheel design eliminates squeegee adjustments
 - Easy-to-remove recovery tank
-

Swingo 455B

COMPACT AUTOSCRUBBER DRIER

With its compact size, ergonomic handle and versatility, the Swingo 455 B is efficient in all types of small or congested hard floor areas. Cleaning along walls and under tables is easy due to the adjustable-height and flexible handle and the dual axle system.



AVAILABLE IN 28" CLEANING WIDTH

FEATURES

- Innovative squeegee concept ensures a 100% edge-to-edge water pick-up even in curves and while turning
 - Easily exchangeable brushes and squeegee blades
-

Swingo 2500

BATTERY-POWERED RIDE-ON AUTOSCRUBBER

The patented all-wheel steering system defines new standards in manoeuvrability, making this ride-on machine the best option for cleaning narrow and congested areas. The extremely low noise level, comparable to a vacuum cleaner, makes work more enjoyable and allows for daytime cleaning.



FEATURES

- Functional handle design incorporates a number of features including an intuitive opening mechanism, ergonomic foot operated on/off switch and a convenient cable tidy
 - HEPA filtration option
-

Vento 15S

DRY CANISTER VACUUM

Main powered tub vacuum cleaner is designed for efficient, simple and ergonomic vacuuming while providing enhanced air quality. Two fixed rear wheels and two freely rotating casters ensure maximum stability and manoeuvrability. The new floor tool maximizes dust pick-up and glides easily over surfaces for higher efficiency.



AVAILABLE IN 18" CLEANING WIDTH

FEATURES

- Using the machine in a push or pull motion allowing the end user flexibility in their application
 - Ideal for deep extraction and interim clean
-

Procarpet 45

CARPET CLEANER

For vacuum pick-up and chemical application, this high performance carpet cleaner ensures excellent results. Utilizing interim cleaning will help to extend the time between deep cleaning activities keeping carpets looking better longer without extended dry times. Allows users to select the cleaning application that best fits their needs based on turnaround time and soil levels. The machine can be changed from deep extraction to interim clean simply by changing the chemicals and flipping a switch.

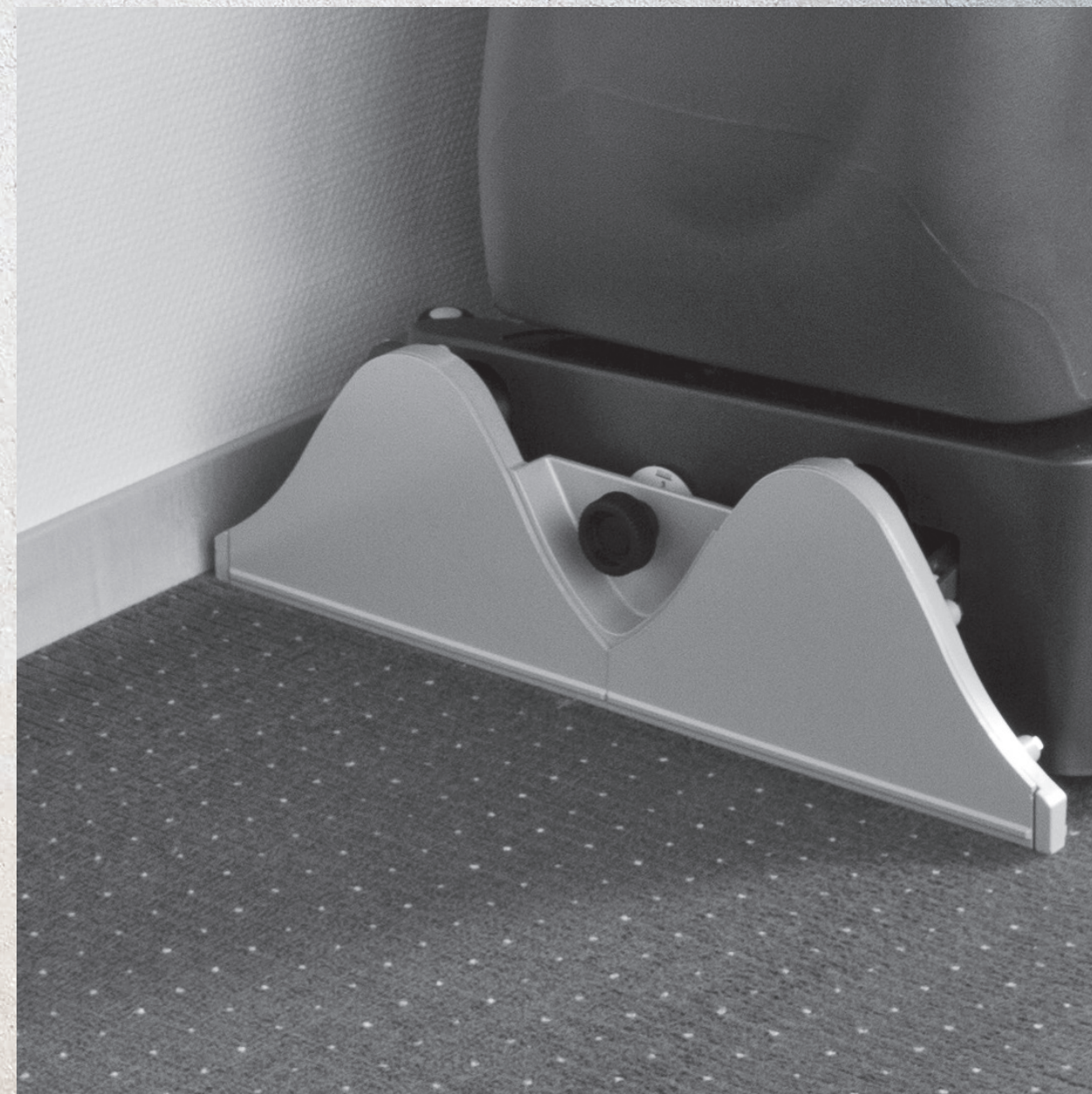

WE GET QUALITY.

ProTeam vacuums are ideal for any commercial cleaning need or preference. These high-quality vacuums can be fitted with high-performance HEPA filters for maximum filtration of unwanted particles.

PRO
PROTEAM
PROTEAM
PROTEAM

SUPER COACH PRO WITH CORD

Available models:

- 6 gallons
- 10 gallons

* Both models are available with the X-Over or the Problade



GO FREE FLEX PRO CORDLESS

Cordless backpack vacuum increases efficiency by saving approximately 1-1.5 hours per 4-hour vacuum shift

FEATURES

- Lightweight. The effect of the backpack on body joints and posture is negligible and similar to walking
- Designed to improve indoor air quality

Super Coach Pro / Go Flex Free Pro

BACKPACK

Backpack vacuum dramatically improves worker productivity, effectiveness and ergonomic comfort. It cleans more than 3 times faster than commercial uprights and 52% faster than a dust mop. Reduces repetitive motions, fatigue and body strain.



AVAILABLE IN 3*, 4, 10, 15, 16
AND 20 GALLONS
*CORDLESS

FEATURES

- Fast and easy liquid debris removal from either the tip and pour spout or the convenient drain hose
- Front mount squeegee provides fast floor stripper recovery and flood restoration applications
- Qwik-Lock® wet filter maximizes tank capacity and provides easy filter changes

Proguard

WET/DRY VACUUM

These vacuums deliver unmatched power, performance and durability and include smart features that make them easier and more convenient to use. Six models that vary in size and functionality - each designed to tackle different maintenance situations.



AVAILABLE IN 12" AND 15"

FEATURES

- Clean hard-to-reach areas with 24-inch wand and hose that stretches to 8 feet
- Ergonomic lightweight handle helps prevent fatigue
- Clear blockages and remove brush roll without tools

Progen

UPRIGHT VACUUM

Added performance and features make it an instant hit with cleaning professionals. The increased manoeuvrability, animated dashboard display and patent pending Snap Lock Lid make this an upright like no other.

HIGH DUSTING KIT

Provides 10-12 feet of effective cleaning reach

Backpack vacuum accessories

FOR ABOVE-THE-FLOOR
AND FLOOR CLEANING

ProTeam vacuums are designed to have a high level of filtration and when a high dusting kit is added, many difficult above-the-floor cleaning solutions are made available to the end-users. Also, ProTeam offers ergonomic floor accessories that increases cleaning quality.



PROBLADE

FEATURES

- Telescopic wand reduces upper body movements and energy needed to work
 - Evenly distributes over the full width of the stroke to vacuum the debris away more efficiently
-

WE'VE GOT THE PRODUCTS. YOU GET THE RESULTS.

Sani Marc is recognized as the leading manufacturer and distributor of high-quality cleaning products for all industry sectors. We have the most advanced, green and biotechnological products available on the market today. Our catalogue features more than 10,000 specialized products.



WE'VE GOT THE TEAM. YOU GET THE SERVICE.

Our multidisciplinary team includes highly-trained mobile technicians, technical service representatives and system engineers who will work with you to evaluate your needs and provide you with personalized service before, during and after purchase.

We also service all our equipment and have the largest inventory of replacement parts in the country, which means you get fast service and delivery.

WE'VE GOT THE TECHNOLOGY. YOU GET THE CUTTING EDGE.

Technology and innovation are at the core of all our projects. Our goal is always to streamline the cleaning process and maximize the efficiency of our clients' workforces. That's why our R&D department is always working the most advanced high-performing equipment and designs that respect the environment and are safe to operate.

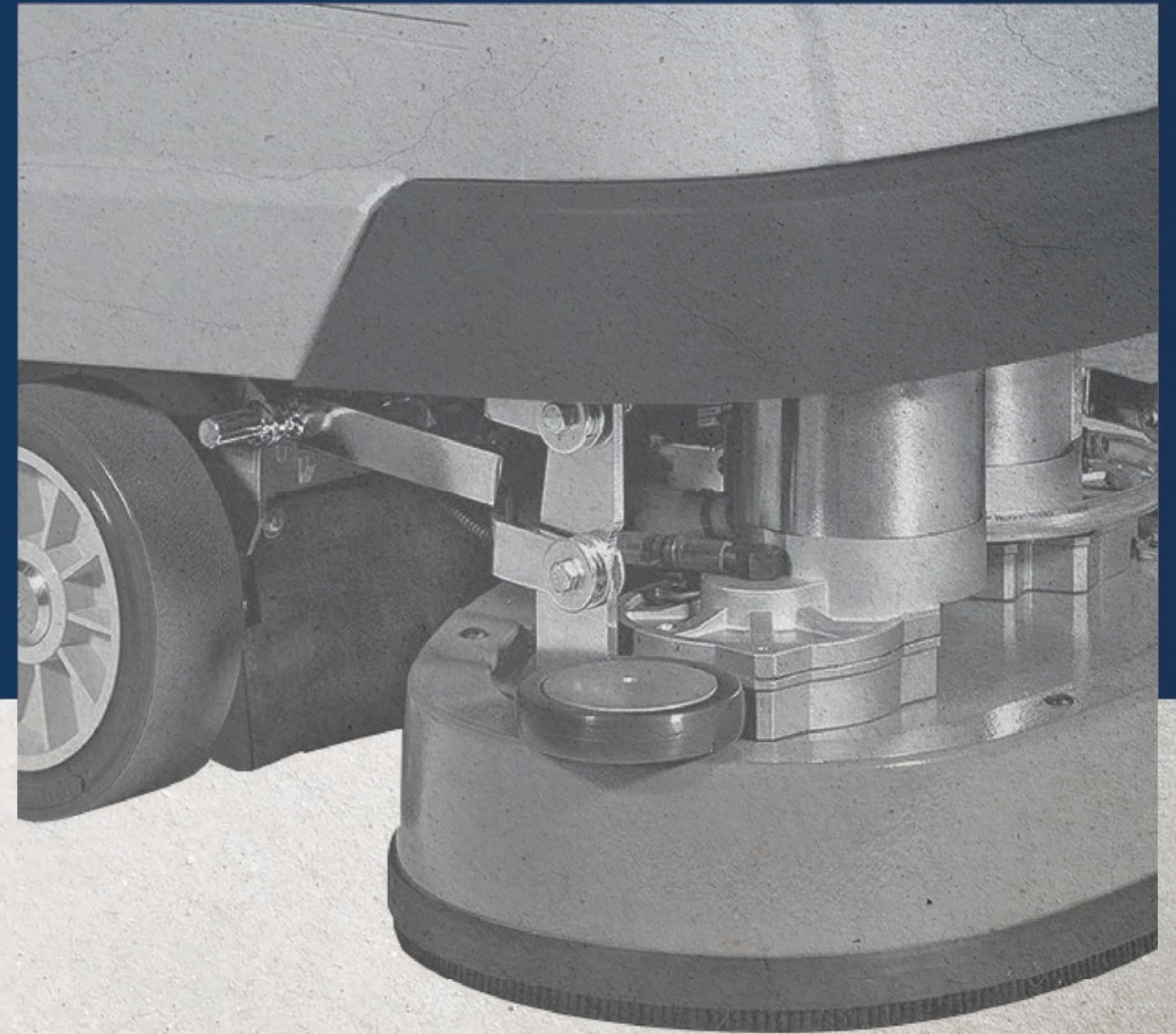

**WE'VE
GOT THE
DEALS.
YOU GET
YOUR
MONEY'S
WORTH.**

We have advantageous financing plans so you can get the equipment you need today. We also offer preventative maintenance for a full year on almost all of our equipment at no extra cost.*

*Not included for vacuums and some sweepers.

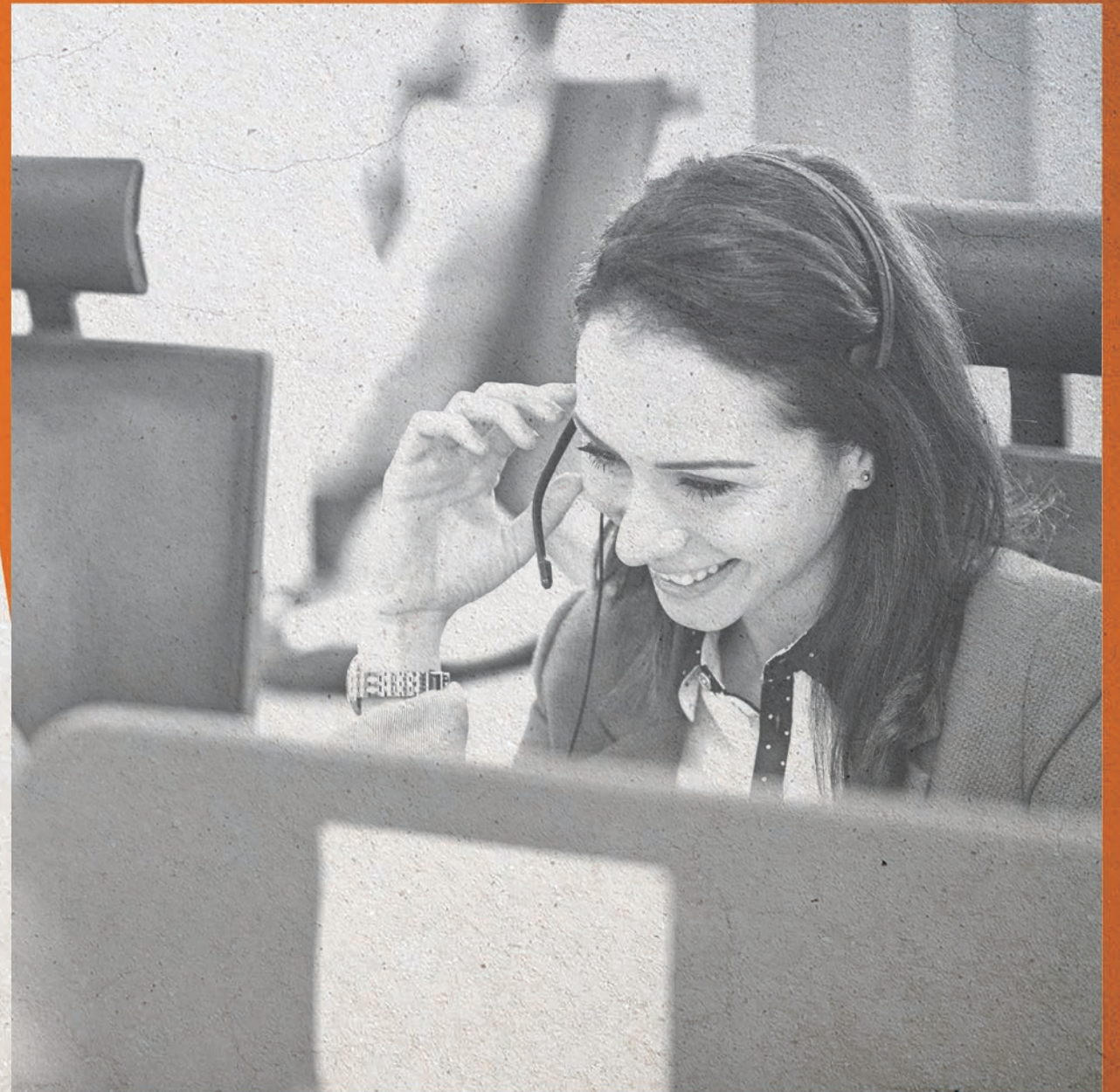

**IT DOESN'T
GET ANY BETTER
THAN THIS.**

GET IN TOUCH WITH US TODAY: **1 800 361-7691**
GET ALL THE DETAILS AT: **SANIMARC.COM/WEGETIT**

WE GET IT WE GET IT WE GET IT WE GET IT WE GET IT



SANI MARC