

Exova Warringtonfire
Chiltern House
Stacking Lane
Hughenden Valley
High Wycombe
Buckinghamshire
HP14 4ND

T: +44 (0) 1494 569 800
F: +44 (0) 1494 564 895
E: globalfire@exova.com
W: www.exova.com



Testing, calibrating, advising.

Title:

Global Assessment
Blankfort 60 & Blankfort
60+ Doorsets for 60
Minutes Fire Resistance

Report No:

Chilt/A12152 Revision E

WF Contract:

391846

Valid From:

12th November 2017

Valid Until:

12th November 2022

Prepared for:

Blankfort Inc.
25, Avenue Cote
St. Ephrem de Beauce
QC
CANADA
GoM 1Ro

Exova Warringtonfire – the new name for BM TRADA

On December 1st 2015, Chiltern International Fire Limited (trading as BM TRADA) commenced trading under the name Exova Warringtonfire.

To coincide with this change, our Technical Reports, Test Reports, Product Assessments, company stationery and marketing collateral have been updated to reflect the Exova Warringtonfire branding.

The validity of all documents previously issued by Chiltern International Fire Limited including certificates, test reports and product assessments is unaffected by this change. A letter to this effect is available upon request by e-mailing globalfire@exova.com

About Exova Warringtonfire

Exova Warringtonfire is part of the Exova Group one of the world's leading laboratory-based testing groups, trusted by organisations to test and advise on the safety, quality and performance of their products and operations. Headquartered in Edinburgh, UK, Exova operates 143 laboratories and offices in 32 countries and employs around 4,500 people throughout Europe, the Americas, the Middle East and Asia/Asia Pacific. With over 90 years' experience, Exova specialises in testing across a number of key sectors from health sciences to aerospace, transportation, oil and gas, fire and construction.

Be assured that whilst the name will change, your service provision and primary contacts have not. What will be available to you is a wider team of testing experts and an extended range of testing capabilities including structural steelwork testing, ventilation duct and damper testing, ASTM testing, water mist system testing and smoke toxicity testing and covering additionally both the rail and marine sectors.

If you have any questions, please do not hesitate to contact a member of the team and we will do our best to answer them. We appreciate your business to date and we look forward to working with you in the future.

Kind regards

Exova Warringtonfire

T: +44 (0) 1494 569 800
E: globalfire@exova.com

Contents

	Page No.
1 Introduction.....	4
2 General Description of Construction	4
3 Leaf Sizes.....	5
4 Configuration	5
5 Leaf Size Adjustment.....	6
6 Glazing	6
7 Overpanels	13
8 Glazed Fanlights & Side Screens	15
9 Door Frames.....	18
10 Leaf Facing Materials	22
11 Intumescent Materials.....	23
12 Edging Materials.....	24
13 Adhesives.....	26
14 Tested Hardware	26
15 Additional & Alternative Hardware	26
16 Door Gaps	31
17 Structural Opening.....	31
18 Fixings.....	31
19 Sealing to Structural Opening	32
20 Insulation.....	33
21 Smoke Control.....	33
22 Conclusion.....	34
23 Declaration by the Applicant	35
24 Limitations	36
25 Validity.....	36
Appendix A - Performance Data	37
Appendix B - Proprietary 60 Minute Glazing Systems.....	39
Appendix C - Revisions	41
Appendix D - Data Sheets	42

1 Introduction

This document constitutes a global assessment report relating to Blankfort Inc. Blankfort 60 & Blankfort 60+ fire resisting doorsets. The assessment uses established extrapolation and interpretation techniques in order to extend the scope of application by determining the limits for the design based on the tested constructions and performances obtained. The assessment is an evaluation of the potential fire resistance performance, if the elements were to be tested in accordance with BS 476: Part 22: 1987.

2 General Description of Construction

2.1 Blankfort 60

The basic tested construction for Blankfort 60 door leaves comprises the following:

Element	Material	Dimensions (mm)	Min. Density (kg/m ³)
Core (lamels of one of the following tested species)	Eastern White Pine	Lamel size: Max. 20 – 36 wide x 36 thick	450*
	Grey Pine	Lamel size: Max. 20 – 36 wide x 36 thick	500*
	Spruce	Lamel size: Max. 20 – 36 wide x 36 thick	400-500*
Top rail	Same material as core	100 wide	As core
Facings	Chipboard (particleboard)	9 thick	650*
	MDF	9 thick	720*
Lippings	Hardwood	Min. 6 thick	582

Note: * Stated nominal density; not checked by laboratory.

2.2 Blankfort 60+

The basic tested construction for Blankfort 60+ door leaves comprises the following:

Element	Material	Dimensions (mm)	Min. Density (kg/m ³)
Core (lamels of one of the following tested species)	Eastern White Pine	Lamel size: Max. 20 – 36 wide x 30 thick	450*
	Grey Pine	Lamel size: Max. 20 – 36 wide x 30 thick	500*
	Spruce	Lamel size: Max. 20 – 36 wide x 30 thick	400-500*
Top rail	Same material as core	100 wide	As core
Facings	Sub-face Chipboard (particleboard)	9 thick	650*
	Outer-face MDF	3 thick	720*
Lippings	Hardwood	Min. 6 thick	582

Note: * Stated nominal density; not checked by laboratory.

2.3 Blankfort 60+ Top & Bottom Rail

The basic tested construction for Blankfort 60+ Top & Bottom Rail door leaves comprises the following:

Element		Material	Dimensions (mm)	Min. Density (kg/m ³)
Core (lamels of one of the following tested species)		Eastern White Pine	Lamel size: Max. 20 – 36 wide x 30 thick	450*
		Grey Pine	Lamel size: Max. 20 – 36 wide x 30 thick	500*
		Spruce	Lamel size: Max. 20 – 36 wide x 30 thick	400-500*
Top and bottom rail		Same material as core	200 wide	As core
Facings	Sub-face	Chipboard (particleboard)	9 thick	650*
	Outer-face	MDF	3 thick	720*
Lippings		Hardwood	Min. 6 thick	582

Further to the primary construction of the Blankfort 60+ design, the use of a 200mm wide top and bottom rail has been evaluated by test and the additional scope of application is discussed herein. Unless otherwise stated, report sections applying to the Blankfort 60+ construction will also apply to Blankfort 60+ top and bottom rail.

3 Leaf Sizes

Assessment for increased leaf dimensions is based on the design's performance and the characteristics exhibited during test. Data sheets specifying the maximum assessed leaf sizes and graphs showing the permitted gradient between maximum height and width are contained in appendix D.

Doorsets containing leaves with smaller dimensions than those stated are deemed to be less onerous and are therefore automatically covered.

Test RF96073, conducted on a double leaf, double acting doorset, with leaf dimensions of 2138mm x 916mm, achieved 64 minutes integrity and is used to calculate the leaf size parameters for Blankfort 60.

Test RF01052/A, conducted on an unlatched, double leaf, single acting doorset including overpanel, with leaf dimensions of 2396mm x 850mm, achieved 63 minutes integrity and is used to calculate the leaf size parameters for Blankfort 60+.

Test RF08080, conducted on an unlatched, double leaf, single acting doorset, with leaf dimensions of 2750mm x 915mm, achieved 65 minutes integrity and is used to calculate the leaf size parameters for Blankfort 60+ when fitted with a top and bottom rail.

4 Configuration and Orientation

Based on the test evidence listed in appendix A, this assessment covers the following doorset configuration:

Abbreviation	Description
LSASD & ULSASD	Latched & unlatched, single acting, single doorsets
DASD	Double acting, single doorsets
LSASD+OP & ULSASD+OP	Latched & unlatched, single acting, single doorsets + overpanel
DASD+OP	Double acting, single doorset + overpanel
LSADD & ULSADD	Latched & unlatched, single acting, double doorsets
DADD	Double acting, double doorsets
LSADD+OP & ULSADD+OP	Latched & unlatched, single acting, double doorsets + overpanel
DADD+OP	Double acting, double doorsets + overpanel

Unequal leaf double doorsets are covered by this assessment with no restriction on the smaller leaf dimension.

4.1 Orientation

The primary fire resistance tests for this design were all conducted with the doorset hung such that the door leaf opened towards the fire, which is considered the most onerous orientation in terms of fire resistance performance. Based on this testing, assessment is made that doorsets to this design may be hung to open either away from or towards the fire risk side of the doorset.

5 Leaf Size Adjustment

5.1 Blankfort 60 & Blankfort 60+ (Top Rail Only)

Leaves may be reduced in width without restriction. Reduction in height must be primarily from the bottom edge, but if reduction is made from the top edge, a top rail dimension of 100mm must be maintained.

Lipping reduction may be made to facilitate site fitting, providing the minimum dimensions specified in section 12 are maintained.

5.2 Blankfort 60+ (100mm Wide Top & 100mm Bottom Rail Fitted)

Leaves may be reduced in width without restriction. Reduction in height can be made from the top or bottom edge to a maximum of 100mm. This is to ensure that a minimum of 100mm top and 100mm bottom rail is maintained.

Lipping reduction may be made to facilitate site fitting, providing the minimum dimensions specified in section 12 are maintained.

6 Glazing

The testing conducted on Blankfort 60 and Blankfort 60+ has demonstrated that the designs are capable of tolerating glazed apertures, whilst providing a margin of over performance. Glazing is therefore acceptable within the following parameters:

The maximum assessed glazed area for all configurations is 0.72m²; however, it is possible to increase the glazed aperture to 1.1m² providing 10mm Pyrodur (60-10) glass is used in conjunction with system 2 listed in section 6.1.

6.1 Assessed Glazing Systems

The glazing system may be as tested, or alternatively one of the following tested proprietary systems:

Glazing System	Manufacturer
1. Therm-A-Glaze 60	Intumescent Seals Ltd.
2. Fireglaze 60	Sealmaster Ltd.
3. System 90+	Lorient Polyproducts Ltd.
4. Pyroglaze 60	Mann McGowan Ltd.
5. System 36/15	Lorient Polyproducts Ltd.
6. System 63 (circular apertures only)	Lorient Polyproducts Ltd.

6.2 Assessed Glass Products

Assessed glass types are as follows:

Glass Type	Manufacturer	Thickness (mm)	Max. Area (m ²)
1. Pyroshield	Pilkington Ltd.	6 & 7	0.72
2. Pyroshield 2 (see section 6.5)	Pilkington Ltd.	6 & 7	0.71
3. Pyran S	Schott Glass Ltd.	6	0.72
4. Pyrostem	Pyroguard UK Ltd.	6	0.72
5. Pyrodur 60-10 (see note 5)	Pilkington Ltd.	10	1.1
6. Pyroguard EW MAXI	Pyroguard UK Ltd.	11	0.72
7. Pyranova 15-S2.0	Schott UK Ltd.	11	0.72
8. Pyrobelite 12	AGC Flat Glass UK	12	0.72
9. Pyrodur 60-20	Pilkington Ltd.	13	0.72
10. Swissflam Lite (see note 4)	Vetrotech St.-Gobain AG	14	0.72
11. Pyroguard EI 30	Pyroguard UK Ltd..	15	0.72
12. Pyrostop 30-10	Pilkington Group Ltd.	15	0.72
13. Pyrobel 16	AGC Flat Glass UK	16	0.72
14. Pyrobel 25 (see section 6.4.1)	AGC Flat Glass UK	25	0.72
15. Pyrostop 60-101 (see section 6.4.2)	Pilkington Ltd.	23	0.72

Notes:

- All glass types must be fitted strictly in accordance with the manufacturers' tested details/installation requirements, particularly with reference to suitable tolerances for expansion of the glass pane.
- Glass types 6 and 10 - 13 are fully insulating for 30 minutes in terms of the criteria set out in BS 476: Part 20: 1987.
- Glass types 14 and 15 are fully insulating for 60 minutes in terms of the criteria set out in BS 476: Part 20: 1987.
- May only be used with the Vetrotech glazing system depicted in appendix B.
- The 10mm Pyrodur (60-10) glass type may be used with all appropriate glazing systems listed in section 6.1. However, for aperture sizes in excess of 0.72m² to maximum 1.1m², the glass must be installed using glazing system 2 as listed in section 6.1.

6.3 Glazing Beads & Installation

Glazing beads must be from hardwood as specified in the following table:

Material	Profile	Min. Density (kg/m ³)	Application
Hardwood	Splayed	640	All proprietary systems detailed in 6.1 and appendix B
Hardwood	Square	640	Proprietary systems 1 and 2 as specified in 6.1 and glass types 6 & 10 - 15 as specified in 6.2

Sectional drawings detailing the tested and approved glazing system are contained in appendix B.

Notes:

1. Beech, *Fagus Sylvatica*, is not permitted for 60 minute applications.
2. Glazing beads must be retained in position with 60mm long steel pins or 60mm long No. 6 - 8 screws, inserted at 35 - 40° to the plane of the glass (or perpendicular to the bead splay) at no more than 50mm from each corner and at 150mm maximum centres
3. The following minimum pin specification is permitted and is considered suitable for gun (pneumatically) fired applications:

3.1 Option 1 – Round, Oval and Rectangular shaped pins:

- Minimum Standard Wire Gauge (SWG) 16
- Minimum cross section area of 2.03mm²
- Minimum linear dimension 1.6mm in any direction

Round pin diameter (mm) = minimum 1.6mm

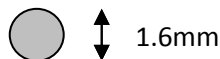

Oval/rectangular pin minimum diameter linear dimension = 1.6mm



3.2 Option 2 – Rectangular shaped pins:

- Minimum Standard Wire Gauge (SWG) 16
- Minimum cross section area of 2.24mm²
- Minimum linear dimension 1.4mm in any direction

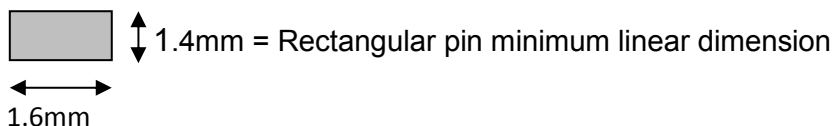

The following plan view illustrates the required orientation of rectangular pins in relation to the plane of the glass, showing the 1.6mm (long) dimension oriented perpendicular to the glass, where possible:



Note:

There are many pins/brads on the market which are sold as SWG 16 but are often below the minimum dimensions stated above. The use of these pins is not covered by the scope of this assessment

4. Glazed openings must not be less than 100mm from any door edge. Multiple apertures are acceptable within the permitted glazed area, with a minimum dimension of 80mm of core between apertures
5. A square bead profile may be used as an alternative to the splayed beads subject to the restricted glass types and glazing systems specified in the table above. See appendix B for square bead options
6. Aperture shape is not restricted, providing the glazing system and beads are compatible with that shape
7. False timber beads must not be applied across the glass face without specific test evidence to justify the system used
8. All timber for glazing beads must be hardwood of straight grained joinery quality, free from knots, splits and checks.

6.4 60 Minute Insulating Glass

The following sections are specific for the installation of the 60 minute insulating glass types; the sections below take precedence over the details given for all other glass types in sections 6.1 and 6.3.

6.4.1 Pyrobel 25 – AGC Flat Glass

Glazing beads must be retained in position with 60mm long No. 6 - 8 screws, inserted at 30° to the vertical at no more than 50mm from each corner and at 150mm maximum centres.

Glazing beads are to be made from hardwood of minimum density 640kg/m³, which is to be straight grained joinery quality, free from knots, splits and checks.

Glazed openings must not be less than 100mm from any door edge. Multiple apertures are acceptable within the permitted glazed area, with a minimum dimension of 80mm of core between apertures.

Aperture shape is not restricted, providing the glazing system and beads are compatible with that shape.

Chamfered glazing beads are to be 30mm (h) x 17.5mm (w) including a 5mm x 5mm bolection return and 20° chamfer.

Square glazing beads are to be 20mm (h) x 17.5mm (w) including a 5mm x 5mm bolection return.

The glazing system is depicted below:

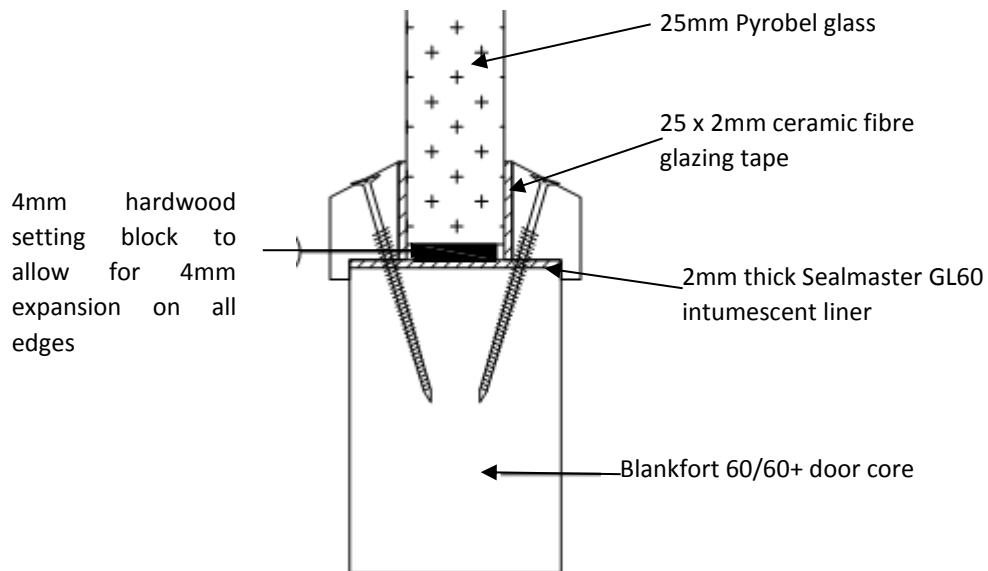

6.4.2 Pyrostop 60-101 – Pilkington Ltd.

Glazing beads must be retained in position with 60mm long No. 6 - 8 screws, inserted at 30° to the vertical at no more than 50mm from each corner and at 150mm maximum centres.

Glazing beads are to be made from hardwood of minimum density 640kg/m³, which is to be straight grained joinery quality, free from knots, splits and checks.

Glazed openings must not be less than 100mm from any door edge. Multiple apertures are acceptable within the permitted glazed area, with a minimum dimension of 80mm of core between apertures.

Aperture shape is not restricted, providing the glazing system and beads are compatible with that shape.

Chamfered glazing beads are to be 30mm (h) x 17.5mm (w) including a 5mm x 5mm bolection return and 20° chamfer.

Square glazing beads are to be 20mm (h) x 17.5mm (w) including a 5mm x 5mm bolection return.

The glazing system is depicted below:

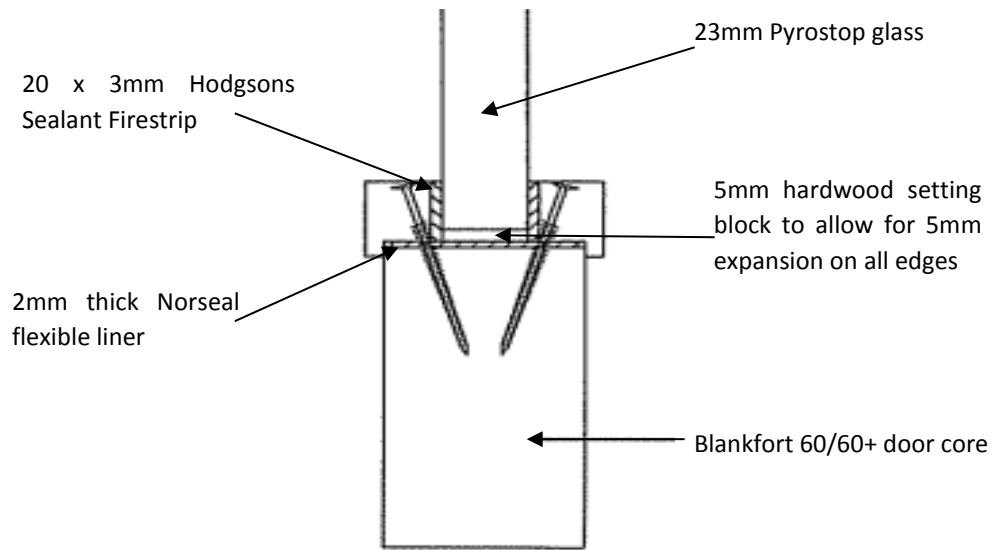

6.5 Pyroshield 2

The following table details the maximum pane sizes and approved glazing systems permitted for Pyroshield 2 in the Blankfort 60/60+ doorset designs:

Glass Type	Glazing System (section 6.1)	Maximum Pane Size* (height x width – mm)	Maximum Area (m ²)
Pyroshield 2	1	1300 x 550	0.715
	3	1300 x 310	0.4

* The heights and widths listed are the maximum single dimensions allowable for an individual pane utilising the relevant glazing system; maximum dimensions may not be increased even if the other dimension for the pane is reduced.

Glazed openings must not be less than 100mm from any door edge. Multiple apertures are acceptable up to the maximum approved area, with a minimum dimension of 80mm between apertures. The aperture shape is not restricted, providing the intumescent material and beads are proven to be compatible with that shape.

Glazing beads must be retained in position with 60mm long steel pins meeting the specification in section 6.3; or 60mm long No. 6 - 8 screws, inserted at 35 - 40° to the vertical at no more than 50mm from each corner and at 150mm maximum centres.

Timber for glazing beads must be straight grained joinery quality, free from knots, splits and checks.

False timber beads must not be applied across the glass face without specific test evidence to justify the system used.

Sectional drawings detailing the tested and approved proprietary glazing systems are contained in appendix B.

7 Overpanels

7.1 Blankfort 60

Overpanels of the same construction as the door leaves may be used with Blankfort 60, provided that a transom is fitted between the leaf head and overpanel. The transom must be to the same specification as the door frame (see the note under the table in section 9.1) and the overpanel must be fully contained within the door frame (see following diagram).

7.2 Blankfort 60+

Overpanels of the same construction as the door leaves may be used with Blankfort 60+ either with a transom or with a flush junction, where the bottom lipping of the overpanel and head lipping of leaves are either rebated together or square to provide a flush junction. In either case the overpanel must be fully contained within the door frame (see following diagram).

If a transom is required to separate the leaf heads from the overpanel, it must be to the same specification as the door frame (see the note under the table in section 9.1).

7.3 General

Joints between the transom and door frame must be either mortice and tenon joints or butt joints (see section 9.2).

Either method requires joints to be tight, with no gaps, and require mechanical fixing with the appropriate size ring shank nails or screws. Butt joints must be additionally bonded with urea formaldehyde or equivalent.

All overpanels must be fixed by screwing through the rear of the frame with steel screws passing at least 30mm into the centre line of the overpanel. Fixings must be no more than 100mm from each corner and a maximum of 250mm centres in between.

The intumescent seals specified for the jambs in appendix D must also be fitted to all concealed edges of the overpanel. The seals may be fitted in the overpanel edges or alternatively in the frame reveal.

The intumescent seal specification for flush overpanel assemblies (junction between leaf heads and overpanel) must comply with the details given in appendix D.

Maximum overpanel dimensions are as follows:

Configuration	Height (mm)	Width (mm)
Single doorsets	2000	Overall door width
Double doorsets	1500	Overall door width

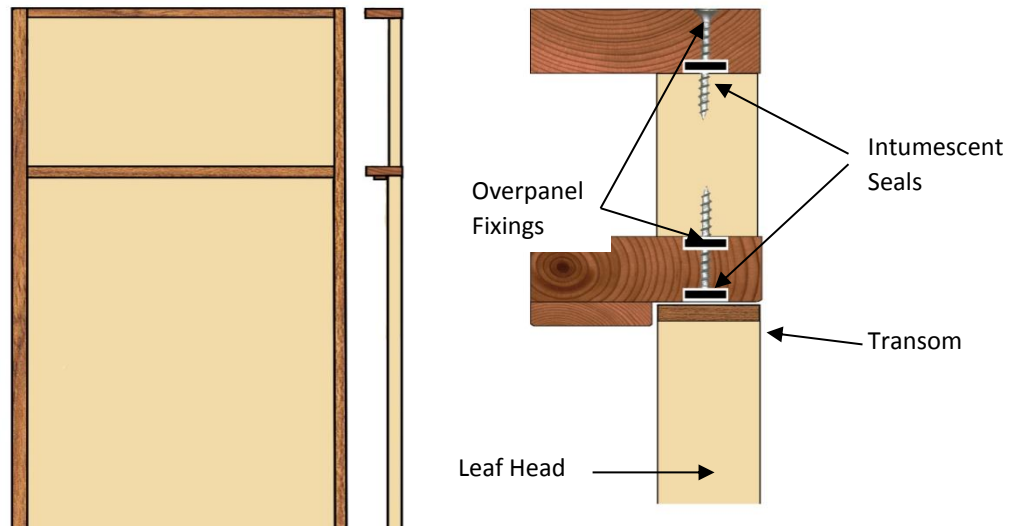

Note: Drawing is representative of doorset construction; actual construction must comply with the specification contained in this document.

8 Glazed Fanlights & Side Screens

8.1 General

It is our assessment that Blankfort 60 and Blankfort 60+ may include glazed fanlights or side screens. The timber frame and glazing beads must be hardwood with a minimum density of 640kg/m³, whilst the frame section must be a minimum of 70mm x 44mm. Other details of the door frame and screen construction must comply with the specification contained in section 9.

The maximum assessed fanlight and side screen dimensions are detailed in the table below, subject to the following restriction:

- The glazing system and glass must be able to demonstrate adequate performance when tested as a window or screen in accordance with BS 476: Part 22: 1987 or BS EN 1634-1, at the pane dimensions to be installed.

Screen Element	Configuration	Height (mm)	Width (mm)
Fanlight	Single & double doorsets	≤600	Overall door width
Side Screen	Single & double doorsets	Overall door height	≤600

NB: MDF frame doorsets are not assessed for glazed fanlights or side screens without specific test evidence (see section 9.1 for options).

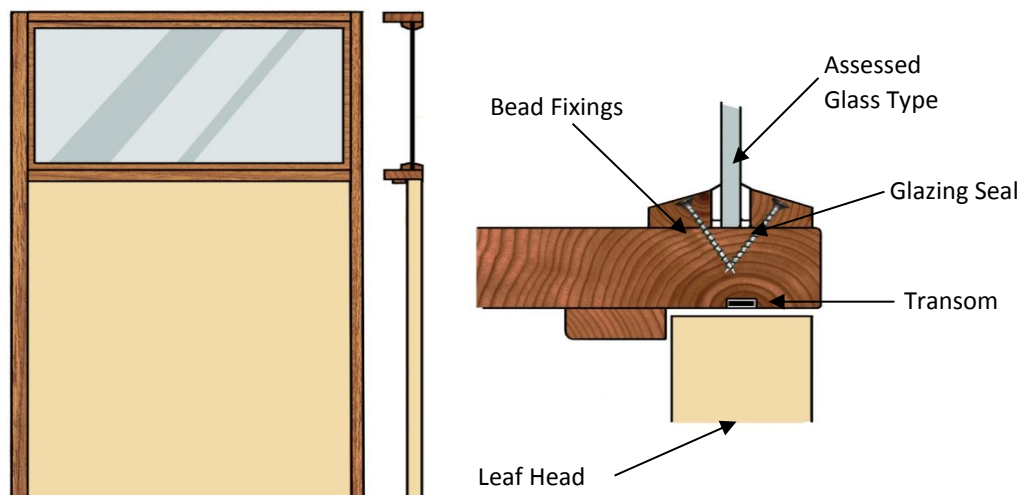

Note: Drawing is representative of doorset construction; actual construction must comply with the specification contained in this document.

8.2 Common Frame Sections

The following drawings depict possible constructions of common frame sections for the screens and door frame jambs:

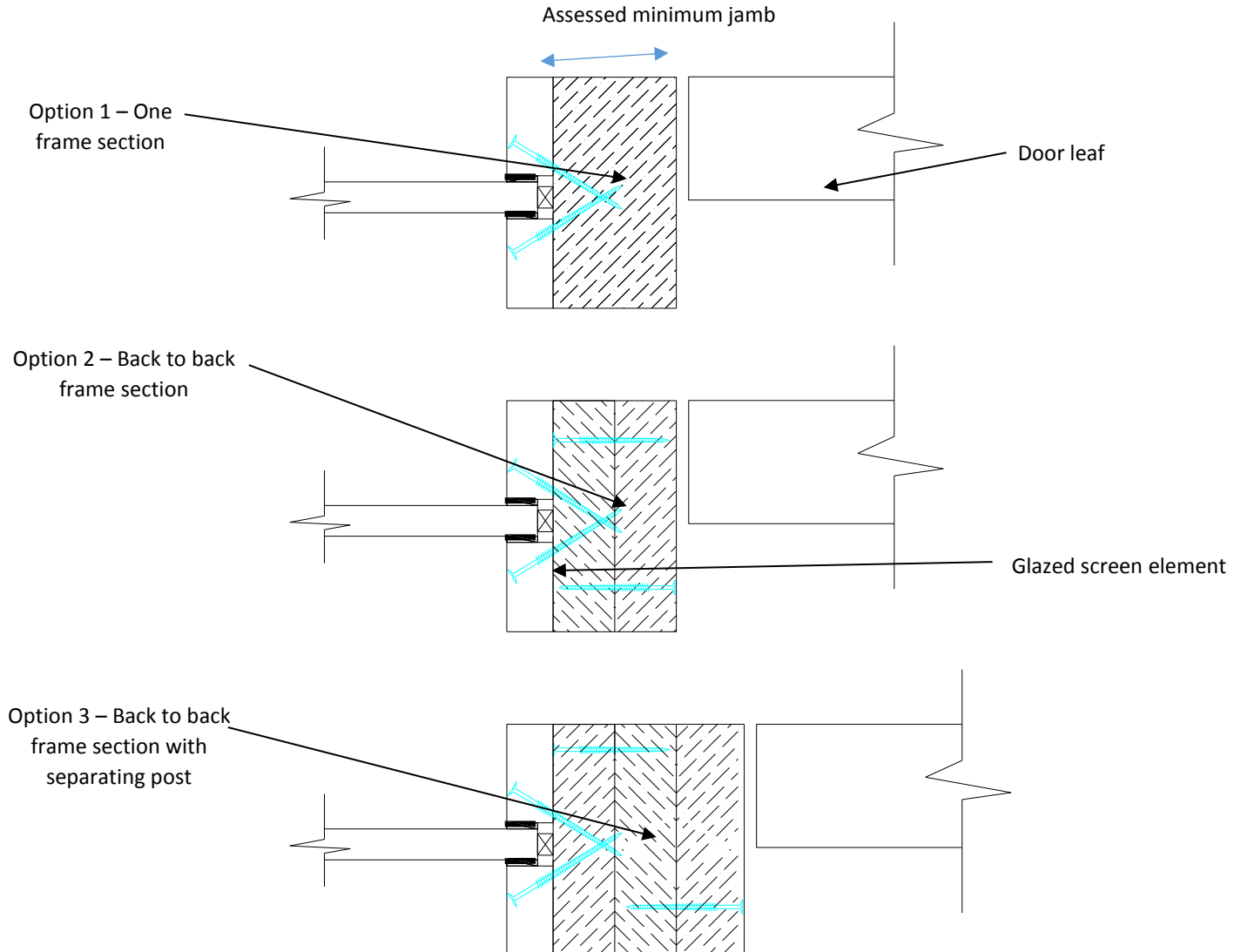

When using separate sections of timber, as shown above (option 2 and 3), each section must be suitably fixed to one another using appropriate steel screw fixings and glued using one of the adhesives approved for the lipping in the adhesive section of this report. Screws must be fixed at 600mm centres and locate to approx 2/3 depth of the adjacent timber section. The overall frame section and material must match that given in this assessment for each glass type and glazing specification. Joints must be tight with no gaps.

It is permitted to include maximum 3mm (w) x 3mm (d) quirks at the junction of each timber section for option 2 and 3.

Drawing is representative of each type of common frame member; actual construction in terms of intumescent seal location and material, etc. must be as the text within this document specifies.

8.3 Screen Elevations

The following drawing depicts a possible door and glazed screen configuration. The diagram is for information only. All details to remain as specified herein:

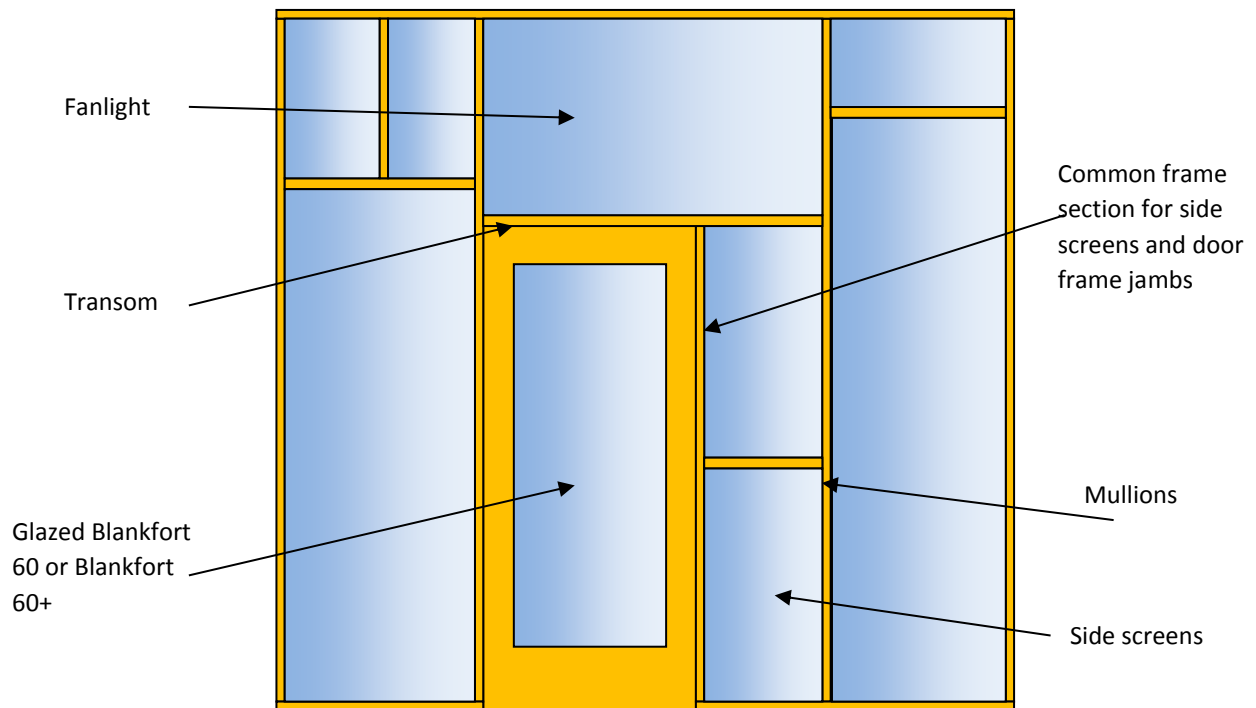

8.4 Specific Glass Types

The following sections provide a scope of approval for different glass types when used for glazing fanlights or side screens. Fanlights may be used in conjunction with side screens subject to the specification given for each of the glass types.

Unless stated in the following sections, all construction details for the doorset must remain as specified in the main assessment.

8.4.1 10mm Pyrodur 60-10 – Pilkington Ltd

Transom/mullion details:

- Minimum 95mm deep x 45mm thick hardwood (min. density 640kg/m³). This timber section can be used for both door frame jambs and transoms above doors included within screens and for the perimeter framing of the screen and the transoms and mullions separating individual panes of glass within the fanlights and side screens.

Glazing details:

- 20mm high x 40mm deep hardwood beads (min. density 640kg/m³). The bead shape may be square or incorporate a 10 - 15° chamfer
- 60mm long size 6 - 8 steel wood screws at maximum of 50mm from corners and 150mm centres inserted at 45° to the plane of the glass
- 20mm x 3mm Hodgsons Sealants Firestrip located between the glass and the beads
- 5mm high x 10mm wide x 40mm long hardwood or non-combustible setting blocks with 5mm expansion allowance to all edges.

Maximum single pane dimensions:

Screen Element		Height (mm)	Width (mm)
Fanlight	From:	735	1000
	To:	815	850
Side Screen		1970	850

- The pane dimensions given above represent the maximum permitted width against maximum permitted height. Panes with smaller dimensions are acceptable
- Transoms supporting single panes above 1000mm wide must be centrally supported by at least one vertical mullion.

Multiple panes:

- The fanlights and side screens may comprise multiple panes of glass providing the total doorset and screen assembly does not exceed 2950mm high and the transom/mullion restrictions above are complied with.

Leaf configurations and screen dimensions:

- The total width of the screen assembly is unlimited
- The screen assembly may only contain 1No. single or double leaf doorset.

9 Door Frames

9.1 Door Frame Construction

Door frames for Blankfort 60 & Blankfort 60+ door designs must be constructed as follows:

Material	Min. Section Size (mm)	Min. Density (kg/m ³)	Application	Leaf Size Range (mm)
Hardwood*	70 x 32	640	All configurations	See appendix D
Hardwood*	70 x 32	615	Single leaf doorsets; in conjunction with 500P intumescent strips	All
MDF*	70 x 30	720	All configurations	See appendix D

Notes:

*If the doorset features a transomed overpanel (constructed using a section of door blank), the door frame must be hardwood with a minimum section of 70mm x 32mm and of the minimum density stated above.

If the doorset features a glazed overpanel (constructed using a section of door blank), the door frame must be hardwood with a minimum section of 70mm x 44mm and of the minimum density stated above.

Beech, *Fagus Sylvatica*, is not permitted for 60 minute applications.

All timber must be straight grained, joinery quality, free from knots, splits and checks.

See appendix D for details of intumescent size and spacing.

A 12mm deep planted stop is adequate for single acting frames whilst double acting frames may be scalloped or square. If frames are square, the maximum radius to the corners of the leaf is 8mm.

Frame joints may be mortice and tenoned, mitred, half lapped or butted and with no gaps. All jointing methods require mechanical fixing with the appropriate size ring shank nails or screws.

For Engineered or finger jointed timber may only be used for this design if suitable test evidence to BS 476 Part 22 or BSEN 1364-1 is available which illustrates integrity performance to this rating for this application.

The following diagram depicts the assessed frame profiles and dimensions:

A = min. 70mm

B = min. 30 - 32mm (see table above)

C = min. 12mm

R = radius from floor spring 8mm max. radius to create a max. 2mm edge profiling

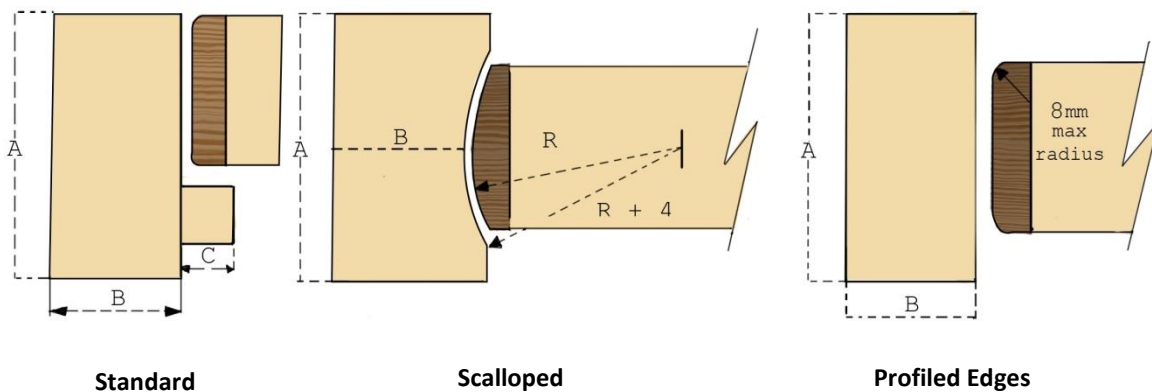

9.1.1 CS Group Acrovyn

Based on the evidence generated in IF13095, timber and MDF door frames may be encapsulated in CS Group Acrovyn meeting the following specification. All other details must remain as required in section 9.1 above, as appropriate.

1. The intumescent detail as specified in section 11 and the relevant (CS Group headed) data sheets contained in appendix D of this assessment must be replicated
2. CS Group Acrovyn must be bonded to the door frame using 3M Scotch-Grip cement 10 contact adhesive or equivalent.
3. See relevant (CS Group headed) data sheets in appendix D of this assessment for maximum permitted leaf sizes
4. The maximum thickness of CS Group Acrovyn used must be 2mm, as per test evidence.

9.2 Door Frame Installation

The following diagrams indicate acceptable and unacceptable door frame installations:

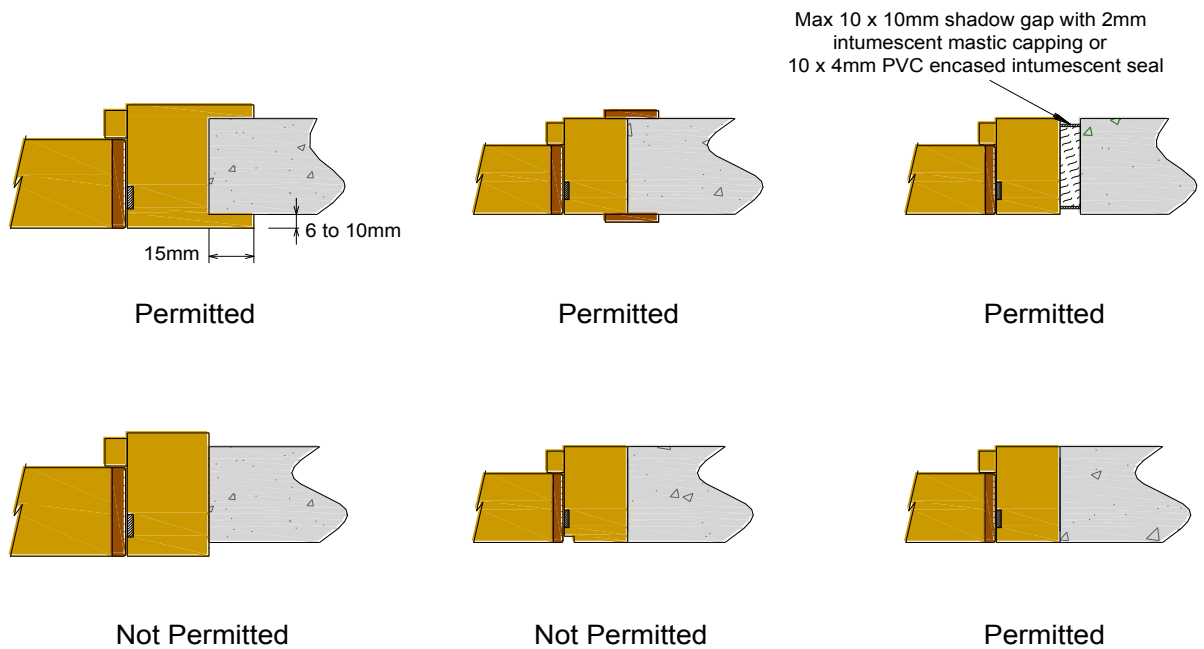

Notes:

1. Drawing is representative of door frame installation only; actual installation must be as the text within this document specifies. See section 19 for sealing to structural opening specification.
2. For the shadow detail depicted above (top right), the sub-frame material must be the same material as approved for the door frame, or a non-combustible board, tightly fitted and with no gaps.

9.3 Door Frame Joints

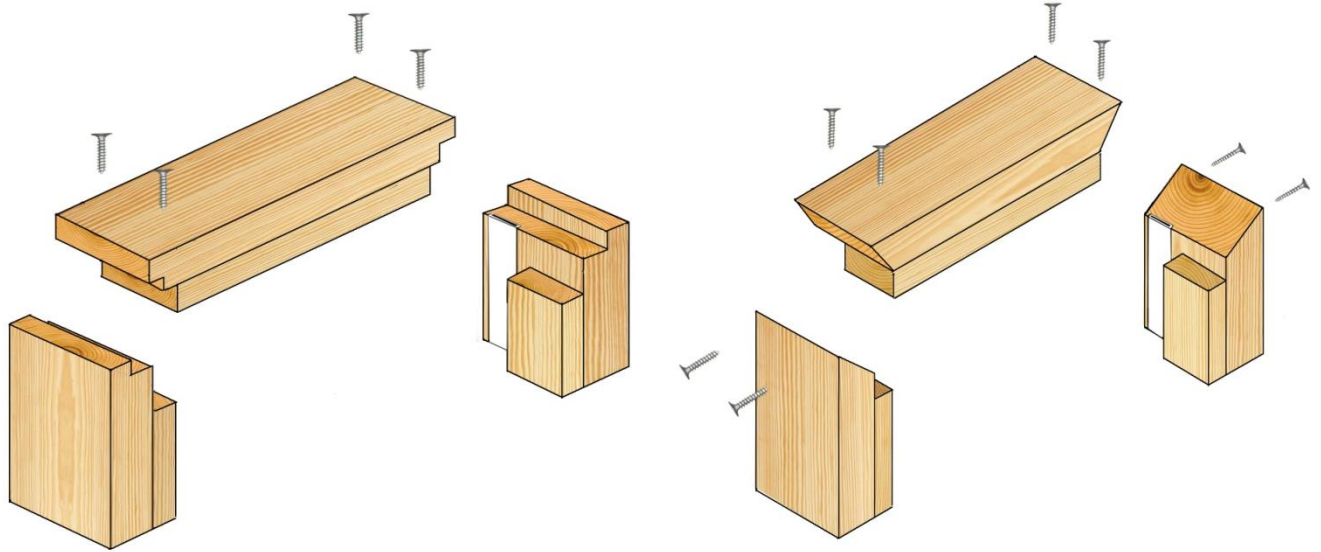

Half Lapped Joint

Mitre Joint

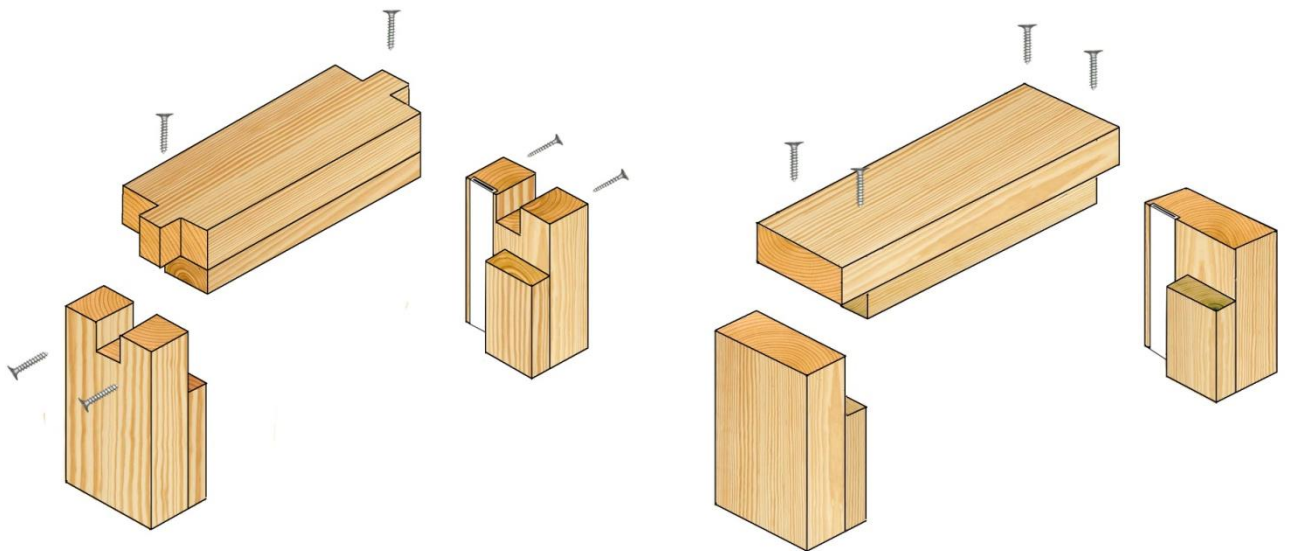

Mortice & Tenon Joint

Butt Joint

Note: Drawing is representative of each type of door frame joint only; actual construction in terms of intumescent seal location and material, etc. must be as the text within this document specifies.

10 Leaf Facing Materials

10.1 Structural Facings

10.1.1 Blankfort 60

At the thickness tested, facings are considered to have structural influence; therefore only the following facing materials have been approved for use with the Blankfort 60 design:

Facing Material	Thickness (mm)	Min. Density (kg/m ³)	Maximum Leaf Size (mm)	Permitted Configurations
Chipboard	9	650	All	All
MDF	9	720	Pyroplex seals only – see appendix D for details	LSASD & ULSASD & DASD

10.1.2 Blankfort 60+

The following outer facing materials have been approved for use with the Blankfort 60+ design in conjunction with the 9mm chipboard sub face (min. density 650kg/m³):

Outer Face Material	Thickness (mm)	Min. Density (kg/m ³)	Maximum Leaf Size (mm)	Permitted Configurations
MDF	3	720	All	All
Eucatex	3	800	All	All
Birch Plywood	3	640	All	All

10.2 Decorative & Protective Facings

The following additional facing materials are permitted for this door design since they would degrade rapidly under test conditions without significant effect:

Facing Material	Maximum Permitted Thickness (mm)
Paint	0.5
Timber Veneers	2
PVC/Plastic Laminates	2
Cellulosic and non-metallic foils	0.5

Notes:

1. Metallic facings are not permitted except for push plates and kick plates
2. The door leaf thickness may be reduced by a total maximum of 0.5mm for calibration purposes in order to accommodate the chosen finish
3. Materials must not conceal intumescent strips
4. PVC/Plastic laminates must not be applied to the edges of leaves (other than those covered by section 12.3 of this assessment).

11 Intumescent Materials

11.1 General

The intumescent materials tested and assessed for this doorset design are as follows:

Application	Location	Product/Manufacturer
Edge Seals	Fitted in the frame jambs or leaf edges	1. PVC encapsulated Palusol 100 – Mann McGowan Fabrications Ltd. or Lorient Polyproducts Ltd. 2. Therm-A-Seal – Intumescent Seals Ltd. 3. 500P – Mann McGowan Fabrications Ltd. 4. Type 617 – Lorient Polyproducts Ltd. 5. Pyroplex – Pyroplex Ltd.
Hinges	Under all hinge blades	1. 1mm Interdens – Dufaylite Developments Ltd. 2. 1mm MAP paper – Lorient Polyproducts Ltd. 3. 1mm Pyrostrip 300 – Mann McGowan Fabrications Ltd. 4. 1mm Therm-A-Strip – Intumescent Seals Ltd.
Lock/Latches	Under forend & keep	1. 1mm Interdens – Dufaylite Developments Ltd. 2. 1mm MAP paper – Lorient Polyproducts Ltd. 3. 1mm Pyrostrip 300 – Mann McGowan Ltd. 4. 1mm Therm-A-Strip – Intumescent Seals Ltd.
Top Pivots & Flush Bolts	Lining all sides of the mortices including the keep	1. 2mm Interdens – Dufaylite Developments Ltd. 2. 2mm MAP paper – Lorient Polyproducts Ltd. 3. 2mm Therm-A-Strip – Intumescent Seals Ltd. 4. 2mm Therm-A-Flex – Intumescent Seals Ltd.

The seal specification for each configuration is contained in appendix D.

11.2 Anti-Ligature Intumescent Detail

To help maintain the anti-ligature status of fire resisting doorsets installed within mental health facilities it is necessary to provide for the option of fitting perimeter intumescent seals in short lengths (minimum 200mm).

Investigative testing carried out by EXOVA WARRINGTONFIRE has shown that the fitting of perimeter intumescent seals as short lengths is acceptable subject to the following specification:

Element	Specification
Leaf Configuration	LSASD & LSADD
Maximum Leaf Size	2100mm (h) x 1000mm (w) providing leaf size is covered by relevant data sheet in appendix D for intumescent seal types listed in this table below
Door Frame	Hardwood (min. density 640kg/m ³) Beech excluded Minimum frame section - 70mm (w) x 32mm (t)
Intumescent Seal Length	Minimum 200mm
Intumescent Seal Type	1. Type 617 – Lorient Polyproducts Ltd. 2. Pyroplex – Pyroplex Ltd. 3. 500P – Mann McGowan Ltd.

Seal Fixing (optional)	20mm long fine gauge steel pins located 25mm from the end of each length of intumescent
------------------------	---

Notes:

1. Each section of intumescent strip must be tightly butted to the next with no gaps
2. It must be ensured that the intumescent material is present for its full length within its PVC casement for each strip section when fitted to the leaf edge or frame reveal
3. All other details must remain as specified herein.

12 Edging Materials

12.1 Blankfort 60

Doors must be lipped in accordance with the following specification:

Material	Dimensions (mm)	Min. Density (kg/m ³)
Timber for lippings must be straight grained, joinery quality hardwood, free from knots, splits and checks	1. Flat = 6 – 18mm thick with a maximum of 2mm profiling permitted at corners of lipping (see section 9.1)	640*
	2. Rounded = 8 – 18mm thick with a radius matching the distance between the leaf edge and floor pivot (see section 9.1)	
	3. Rebated = Not permitted.	

* May be reduced to 615kg/m³ for chipboard faced, single leaf doorsets, only when used in conjunction with 500P intumescent strips and to a maximum leaf size of 2150mm x 930mm.

Notes:

1. Beech, *Fagus Sylvatica*, is not permitted for 60 minute applications.
2. All edges of the leaves must be lipped
3. A 2.5° chamfer is permitted to the lipping at the leading edge of leaves providing the door gaps meet the requirements in section 16.

12.2 Blankfort 60+

The minimum lipping specifications for this design of door leaf are as follows:

Material	Dimensions (mm)	Min. Density (kg/m ³)
Timber for lippings must be straight grained, joinery quality hardwood, free from knots, splits and checks	1. Flat = 6 – 18mm thick with a maximum of 2mm profiling permitted at corners of lipping (see section 9.1)	640*
	2. Rounded = 8 – 18mm thick with a radius matching the distance between the leaf edge and floor pivot (see section 9.1)	
	3. Rebated = 19 – 29 thick with a 26 wide x 12 deep rebate	

* May be reduced to 615kg/m³ for single leaf doorsets, only when used in conjunction with 500P intumescent strips and to a maximum leaf size of 2150mm x 930mm.

Notes:

1. Beech, *Fagus Sylvatica*, is not permitted for 60 minute applications.
2. All edges of the leaves must be lipped
3. Single doorsets are not permitted with rebated vertical edges
4. Only leaf head to overpanel junctions may be rebated
5. A 2.5° chamfer is permitted to the lipping at the leading edge of leaves providing the door gaps meet the requirements in section 16.

12.3 PVC Edge Protectors & Post-Formed CS Group Acrovyn

12.3.1 General

It is possible to fit proprietary edge protectors to this doorset design providing they have suitable supporting test evidence to BS 476: Part 22: 1987 or BS EN 1634-1 when fitted to timber doorsets of similar construction to this design. The end user must satisfy themselves that the test evidence supports the proposed end use application.

12.3.2 CS Group Edge Protectors

The Blankfort 60 and 60+ designs have been tested and are assessed for use with CS Group edge protectors. CS Group edge protectors for fitting at the meeting edges of double doors are supplied pre-formed with the approved intumescent material. The CS Group edge protectors for fitting at the hanging edges (and closing edges of single doors) are supplied without intumescent and require intumescent to be fitted in the frame reveal. The CS Group edge protectors must be used as part of a complete intumescent system and the required intumescent specification and leaf sizes are given in the relevant datasheets in appendix D. CS Group must be contacted for precise installation and fixing details (www.c-sgroup.co.uk).

12.3.3 Post-Formed CS Group Acrovyn

It is possible to encapsulate the Blankfort 60 and 60+ designs by post-forming the leaf in CS Group Acrovyn, based on the supporting test evidence in Chilt/RF11061 and IF13095, and the following specification:

1. CS Group Acrovyn may be wrapped around the vertical edges of the leaf, or the leaf can be fully encapsulated on all four edges
2. The vertical edge detail prior to post-forming must either be lipped with 8mm thick PVC adhered to the leaf edge using 3M Scotch-grip cement 10 contact adhesive or Jowat 609.38 PUR adhesive as tested or equivalent, or hardwood as detailed in this assessment (see section 12.1 for Blankfort 60 and section 12.2 for Blankfort 60+. Rebated timber lippings are not permitted)
3. The horizontal edge detail prior to post-forming does not require lipping but may be lipped with 8mm thick PVC adhered to the leaf edge using 3M Scotch-grip cement 10 contact adhesive or Jowat 609.38 PUR adhesive as tested or equivalent, hardwood as detailed in this assessment (see sections 12.1 & 12.2. Rebated timber lippings are not permitted)
4. The maximum radius of the lipping at the corners of the vertical edges before post-forming must be 9mm, which provides for 11mm external radius after the CS Group Acrovyn has been applied

5. The intumescent detail as specified in section 11 and the relevant (CS Group headed) datasheets contained in appendix D of this assessment must be replicated
6. CS Group Acrovyn must be bonded to the leaf using 3M Scotch-Grip cement 10 contact adhesive or equivalent.
7. See relevant (CS Group headed) datasheets in appendix D of this assessment for maximum permitted leaf sizes
8. The maximum thickness of CS Group Acrovyn used must be 2mm, as per test evidence
9. The CS Group Acrovyn can be provided as pre-formed trays with dimensions to suit the proposed leaf sizes, as well as sheets for post-forming by the door manufacturer.
10. It is permitted to hang leaves fitted with CS Group Acrovyn in timber or MDF door frames meeting the specification given in section 9.1 (not encapsulated with CS Group Acrovyn) or section 9.1.1 (encapsulated with CS Group Acrovyn).

13 Adhesives

The following adhesives must be used in construction:

Element	Product
Core Lamels	X-linked PVA
Facings	X-linked PVA
Lippings	Urea formaldehyde or polyurethane

14 Tested Hardware

14.1 General

The following hardware has been successfully incorporated in the tests on this doorset design:

Element	Product	Size (mm)
Hinges	Royde & Tucker H105 lift-off type hinges	98 x 82 (blade size)
Closers	Dorma TS83V face-fixed overhead closer	See manufacturer's information
Lock/latch	Standard 75mm mortice latches with aluminium lever handles	-
Top pivots & floor springs	Geze TS500 floor springs, Ref. 17632U Geze Type B upper pivot, Ref. 52477U Geze Type C bottom strap, Ref. 07432U Geze stainless steel cover plate, Ref. 52477U	See manufacturer's information

15 Additional & Alternative Hardware

The following section details the permitted scope and constraints for fitting hardware to this door design. The following items of hardware must also bear the CE Mark:

- Latches & locks: Test Standard EN 12209

- Single axis hinges: Test Standard EN 1935
- Controlled door closing devices: Test Standard EN 1154
- Door co-ordinators: Test Standard EN 1158
- Electro mechanically operated locks: Test Standard EN 14846
- Panic exit hardware: Test Standard EN 1125.

15.1 Concealed Overhead Closer

The testing conducted in WF 140704 demonstrated that a 54mm thick door design similar to the Blankfort 60 and 60+ constructions can be fitted with the Dorma ITS 96 concealed overhead closer and provide a minimum of 60 minutes fire resistance.

The closer must have a minimum of 10x4mm perimeter intumescent seal running past both sides of the slide arm in the frame reveal, for the full width of the leaf, and the closer must be fitted with the tested proprietary intumescent pack provided by Dorma referenced: Lorient Polyproducts Ltd. ITS Graphite D/A cover strip.

The closer must be installed in accordance with the manufacturer's instructions and the head of the door frame must incorporate a minimum of 1No. 20x4mm seal centrally fitted in the frame reveal, where the perimeter is not interrupted by the slide channel.

15.2 Latches & Locks

Latches and locks must either be as tested, or alternatively components with the following specification are acceptable:

Maximum forend and strike plate dimensions	235mm high by 25mm wide by 4mm thick
Maximum body dimensions	165mm high by 100mm wide by 18mm thick
Intumescent protection	See section 11
Materials	All parts essential to the locking/latching action (including the latch bolt, forend & strike) to be steel or stainless steel
Location	800 – 1200mm from the threshold

15.3 Hinges

Door leaves must be hung on a minimum of 3 hinges. Leaves over 2400mm high must fit 4 hinges. Hinges with the following specification are acceptable:

Blade height	90 – 120mm
Blade width (excluding knuckle)	30 – 35mm
Blade thickness	2.5 - 4mm
Fixings	Minimum of 4No. 30mm long No. 8 or No. 10 steel wood screws per blade
Materials	Steel, stainless steel or brass with a melting point $\geq 800^{\circ}\text{C}$

Hinge positions	3 hinges	Top: 100 – 180mm from top of blade to head of leaf. Middle: Min. 200mm from top hinge, or equispaced between top & bottom hinges. Bottom: 150 – 250mm from bottom of blade to foot of leaf.
	4 hinges	Top: 100 – 180mm from top of blade to head of leaf. 2 nd : Min. 200mm from top hinge, or equispaced between top & bottom hinges. 3 rd : Equispaced between 2 nd and bottom hinge. Bottom: 150 – 250mm from bottom of blade to foot of leaf.
Intumescent protection		See section 11

15.4 Safehinge

It is possible to fit the Safehinge™ product to the Blankfort 60 and 60+ designs. The end user must satisfy themselves that the test evidence supports the proposed end use application. Distributors of the Safehinge™ product can provide supporting test evidence for this doorset design and must be contacted to confirm exact requirements.

15.5 Automatic Closing

Automatic closing devices must be as tested or surface mounted overhead type closer components that have demonstrated contribution to the required 60 minutes performance of this type of flush doorset design and intumescent specification (as detailed in appendix D), at a similar leaf thickness and when tested to BS 476-22:1987 or BS EN 1634-1.

For double action doors, floor springs and top pivots may be used provided the components have demonstrated contribution to the required 60 minutes performance of this type of flush doorset design and intumescent specification (as detailed in appendix D), at a similar leaf thickness and when tested to BS 476-22:1987 or BS EN 1634-1. The top pivots and frame housing to floorspring assemblies must be protected with a 2mm thick intumescent gasket (as specified in section 11) or alternatively the manufacturers tested intumescent gaskets.

15.6 Flush Bolts

Flush bolts may be incorporated centrally into the top and bottom of one meeting edge, providing the following maximum dimensions are not exceeded and the components are fitted opposite the edge fitted with intumescent strips:

- 200mm long x 20mm deep x 20mm wide

Flush bolts must be steel and the mortice must be as tight to the mechanism as is compatible with its operation. All edges of the mortice of the body and keep must be protected with intumescent gaskets as specified in section 11. Alternatively, the hardware manufacturers tested gaskets may be used.

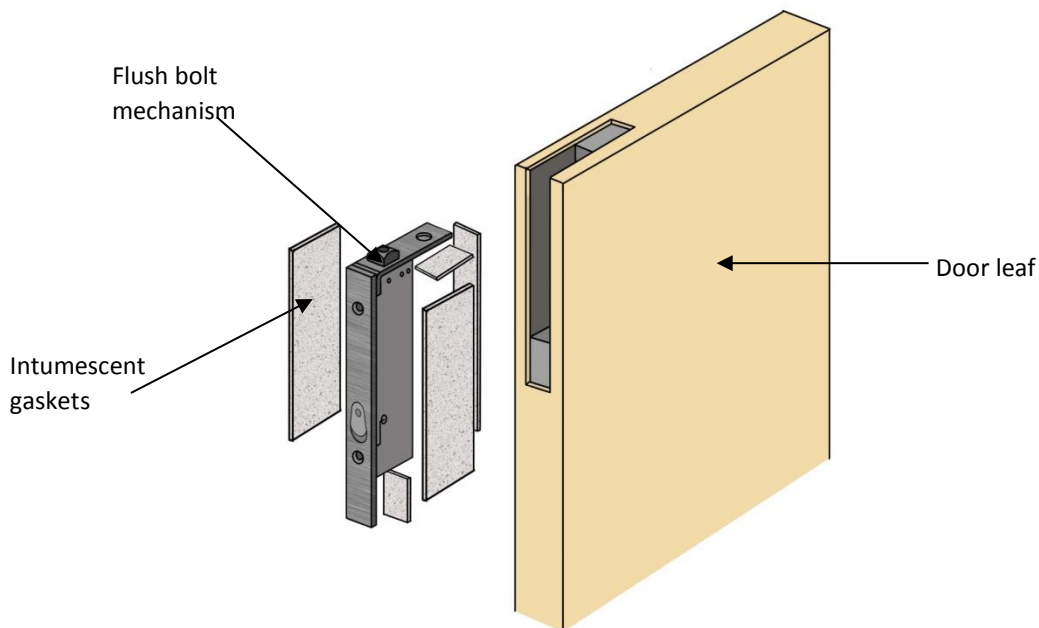

15.7 Pull Handles

These may be surface-fixed to the door leaf provided that they are steel or stainless steel and the length is limited to 1200mm between the fixing points. No additional intumescent protection is required provided that the hole for the bolt through the leaf is tight.

15.8 Push Plates/Kick Plates

Steel or stainless steel face-fixed hardware such as push plates and kick plates may be fitted to the doorsets provided that their fitting requires the removal of no part of the door leaf. These items of hardware are permitted up to a maximum of 20% of the door leaf area if mechanically fixed and a maximum of 30% if bonded with a contact or other thermally softening adhesive. Plates must not return around the door edges.

See section 10.2 for details of non-metallic additional facing materials.

15.9 Door Selectors

These may be freely applied, provided that they are not invasive in the leaf edges or door frames. Those that are invasive will require fire resistance test/assessment evidence to support their use. No additional intumescent protection is required unless test evidence dictates otherwise.

15.10 Door Security Viewers

Door security viewers with brass or steel bodies of a diameter less than or equal to 15mm may be used provided that the through-hole is bored tight to the case of the viewer (maximum tolerance +1mm). Lenses must be glass and the item must be bedded onto a tested intumescent mastic.

15.11 Panic Hardware

Panic hardware may be fitted, provided that its installation does not require the removal of any timber from the leaf, stop or frame reveal and it in no way interferes with the self-closing action of the door leaf.

15.12 Cable-Way

Based on the integrity performance of the doorset construction, with no burn-through of the core material, we consider it acceptable to allow the provision for a concealed cable-way to facilitate electro-magnetic closing/latching mechanisms. The cable-way must be concealed in the following way:

1. A hole drilled centrally through the leaf of maximum 10mm diameter
2. The cable for the electronic closing/latching mechanisms must be no more than 2mm smaller in diameter than the hole through the leaf
3. The cable for the electronic closing/latching mechanism must be PVC encased
4. Cable ways are only permitted for use with latched, single leaf, single acting doorsets with maximum leaf dimensions of 2100mm (h) x 900mm (w)
5. The hole must be located below 1500mm from the threshold and must be spaced a minimum of 90mm from any apertures within the leaf, e.g. glazing, air transfer grilles or letter plates, etc.

This approval is subject to the hardware manufacturer having the appropriate test evidence for the product for use with this type of 60 minute construction. Test evidence generated in steel doorsets is not acceptable. Any tested intumescent gaskets for the lockset, closing mechanism, receiver plate, cable loops, etc. must be replicated.

15.13 Air Transfer Grilles

Air transfer grilles may be fitted providing the product has suitable test evidence to BS 476: Part 22: 1987 or BS EN 1634-1, that demonstrates a minimum of 60 minutes integrity performance when installed within a timber based doorset of comparable thickness. Margins to the leaf edges will remain as detailed for glazing and the position of the unit will be dictated by the pressure regime tested in the proving evidence (normally below mid-height). The area occupied by the air transfer grille must not exceed 0.2m² and must be deducted from the area of glazing, if both elements are fitted.

If it is required to fit air transfer grilles outside of the aforementioned scope, guidance and appropriate test evidence must be sought from the manufacturer of the grille, including permitted numbers of grilles, spacing within the door leaf, additional intumescents, aperture liners and location within the doorset (with respect to pressure regime).

15.13.1 Smoke Control

Smoke control as defined by the performance criteria set out in BS 476: Part 31: Section 31.1 or BS EN 1634-3: 2001 cannot be claimed for a doorset fitted with an air transfer grille(s) unless it is automatically operating on activation of the smoke alarm and has supporting data to the aforementioned test standards for smoke control.

15.14 Acoustic, Weather & Dust Seals

Silicon based flame retardant acoustic, weather and dust seals (e.g. Norsound 710, 720 and Lorient IS1212, IS1511, IS7025, IS7060) may be fitted to this doorset design without compromising the performance, providing their fitting does not interfere with the activation of the intumescent seals or hinder the self-closing function of the leaves.

15.15 Threshold Seals

The following types of automatic threshold drop seals may be recessed in to the bottom of leaves to this design without compromising the performance:

Product	Manufacturer
IS8010si	Lorient Polyproducts Ltd.
RP8Si	Raven Products Ltd.
Schall-Ex Duo L-15	Athmer
NOR810, NOR810S, NOR810dB+	Norsound Ltd.
950.05.513	Hafele (UK) Ltd.

15.16 Letter Boxes/Plates

Letter boxes/plates may be fitted providing the product has demonstrated contribution to the required integrity performance of this type of doorset design, when tested to BS 476: Part 22: 1987, BS EN 1634-1 or BS EN 1634-2, when installed within a timber based doorset of comparable thickness. Margins to the leaf edges must remain as detailed for glazing. The position of the letter box/plate will be dictated by the pressure regime tested in the proving evidence (normally below mid-height).

16 Door Gaps

For fire resistance performance, door gaps and alignment tolerances must fall within the following range:

Location	Dimensions
Door edge gaps	A minimum of 2mm and a maximum of 4mm
Alignment tolerances	Leaves must not be proud of each other or from the door frame by more than 1mm
Threshold	A maximum of 10mm between bottom of leaf and top of floor covering

17 Structural Opening

The supporting construction must be capable of staying in place and intact for the full period of fire resistance required from the doorset.

18 Fixings

The supporting construction must be capable of staying in place and intact for the full period of fire resistance required from the doorset. The frame jambs are to be fixed to the supporting construction using steel fixings at 600mm maximum centres. The fixings must be of the appropriate type for the supporting construction and must penetrate to a minimum depth of 40mm. For doorsets without overpanels or fanlights, it is not necessary to fix the frame head, although packers must be inserted above the jambs and at the meeting stile position. Where overpanels or fanlights are fitted it will be necessary to secure the head of the frame using the fixing specification for the jambs, as stated above.

19 Sealing to Structural Opening

The door frame to structural opening gap must be protected using one of the following methods:

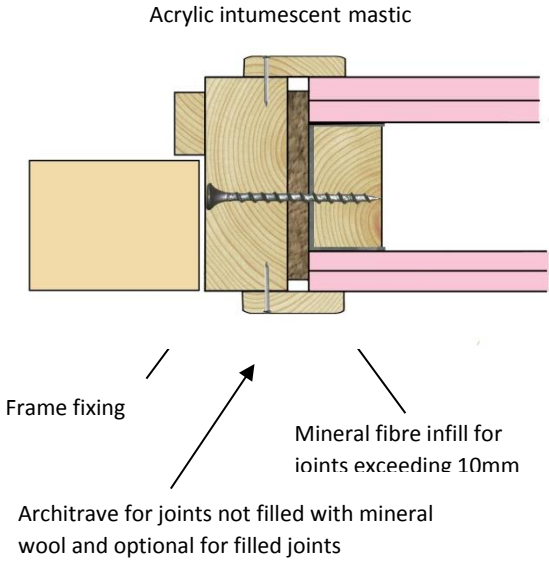
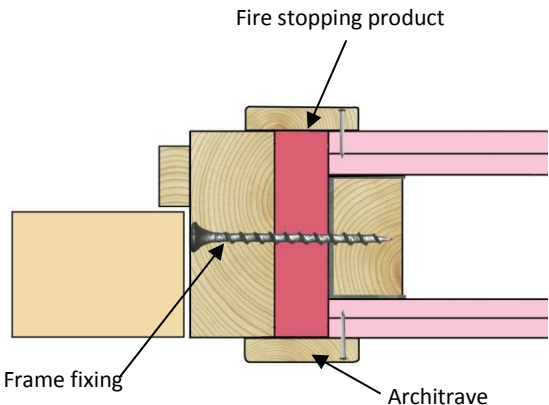
<p>1. Gaps up to 10mm must be sealed on both sides with a 10mm depth of acrylic intumescent mastic, fire tested for this application to BS 476: Part 22: 1987 or BS EN 1634-1. Joints must be fitted with 15mm thick architraves overlapping at least 15mm each side.</p>	 <p>Acrylic intumescent mastic</p> <p>Frame fixing</p> <p>Mineral fibre infill for joints exceeding 10mm</p> <p>Architrave for joints not filled with mineral wool and optional for filled joints</p>
<p>2. Gaps between 10mm and 20mm must be tightly packed with mineral fibre capped on both sides with a 10mm depth of acrylic intumescent mastic, fire tested for this application to BS 476: Part 22: 1987 or BS EN 1634-1. Architraves are optional.</p>	<p>(This diagram is shared with the first method and is not repeated here.)</p>
<p>3. Gaps up to 20mm filled with proprietary fire stopping product (e.g. expanding PU foam or preformed compressible intumescent foam). Products must be tested for this application to BS 476: Part 22: 1987 or BS EN 1634-1. Joints must be fitted with 15mm thick architraves overlapping at least 15mm each side.</p>	 <p>Fire stopping product</p> <p>Frame fixing</p> <p>Architrave</p>

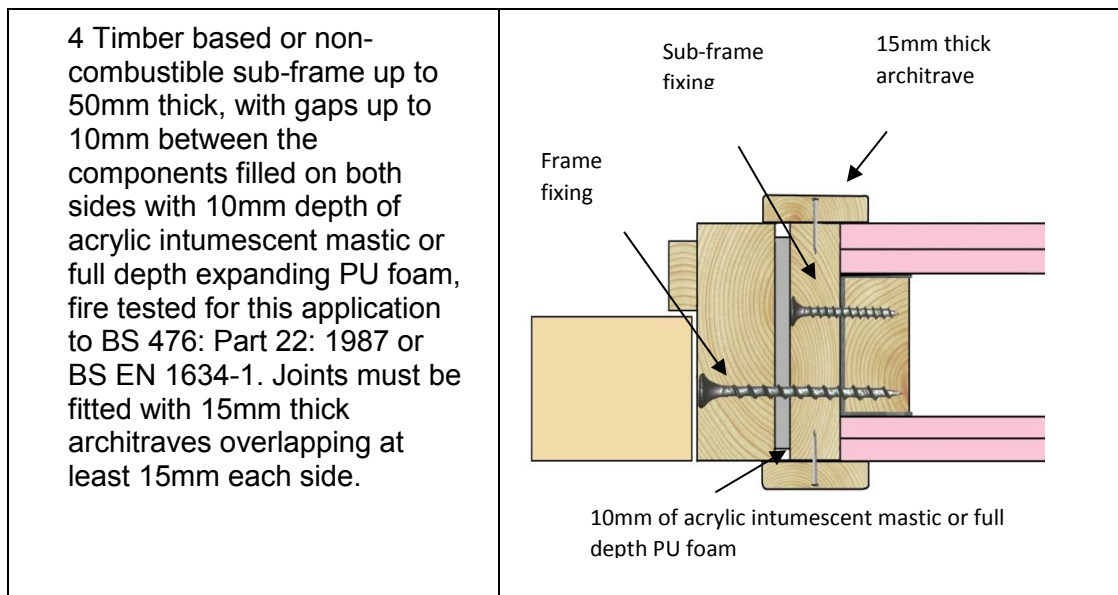

Note: Drawings are representative of doorset construction only; actual construction must comply with the specification contained in this document.

20 Insulation

Insulation performance may be claimed for a doorset to this design meeting the following:

Type	Details
Partially insulating	Doorsets with timber frames incorporating up to 20% of non-insulating glass
Fully insulating	Timber framed, unglazed doorsets or doorsets fitted with 60 minute insulating glazing (see section 6 for details)

21 Smoke Control

21.1 General

If the doorset design is required to provide a smoke control function to comply with Building Regulations, in the absence of a suitable pressurisation system, the doorset must meet one of the following criteria:

- have a leakage rate not exceeding $3\text{m}^3/\text{m}/\text{hour}$ (head and jambs only) when tested at 25Pa under BS 476 *Fire tests on building materials and structures*, Section 31.1 - *Methods for measuring smoke penetration through doorsets and shutter assemblies, Method of measurement under ambient temperature conditions*; or
- meet the additional classification requirement of Sa when tested to BS EN 1634-3: 2004 - *Fire resistance tests for door and shutter assemblies*, Part 3 – *Smoke control doors*.

Smoke seals or combined intumescent/smoke seals that are fitted to the door to achieve the performance requirements specified above must have been tested in accordance with the associated test method. Providing the smoke seals, any interruptions, door gaps, and the type/configuration of the doorset are consistent with the detail tested, the doorset will comply with current smoke control legislation under

Approved Document B; and a suffix 'S' or 'Sa', as appropriate, may be added to the designation. Any other components installed where smoke leakage may occur must also be taken into account.

Note: The incorrect specification and fitting of smoke seals may impair the operation of a doorset and therefore compromise the fire resistance performance. Advice should be sought from the seal manufacturers regarding the correct specification and installation of smoke seals or combined smoke and intumescent seals.

21.2 Further Considerations

Note that there is other guidance available, including BS EN 9999-2017 - *Code of practice for fire safety in the design, management and use of buildings*, which may impose different or additional requirements, such as consideration of the gap between door leaf and threshold.

Responsibility for the appropriate smoke sealing specification and performance of the doors should be agreed between the relevant parties (i.e. specifier, manufacturer, contractor) prior to commencing manufacture and/or installation.

22 Conclusion

22.1 Blankfort 60

It is our opinion that, if the Blankfort 60 doorset design constructed in accordance with the specification documented in this global assessment, were to be tested in the appropriate configuration in accordance with BS 476: Part 22: 1987, it would provide a minimum of 60 minutes integrity and insulation (subject to section 20).

22.2 Blankfort 60+ with Top & Bottom Rail

It is our opinion that, if the Blankfort 60+ doorset design constructed in accordance with the specification documented in this global assessment, were to be tested in the appropriate configuration in accordance with BS 476: Part 22: 1987, it would provide a minimum of 60 minutes integrity and insulation (subject to section 20).

23 Declaration by the Applicant

- 1) We the undersigned confirm that we have read and comply with obligations placed on us by FTSG Resolution No. 82: 2001.
- 2) We confirm that the component or element of structure, which is the subject of this assessment, has not to our knowledge been subjected to a fire test to the Standard against which this assessment is being made.
- 3) We agree to withdraw this assessment from circulation should the component or element of structure be the subject of a fire test to the Standard against which this assessment is being made.
- 4) We are not aware of any information that could adversely affect the conclusions of this assessment.
- 5) If we subsequently become aware of any such information, we agree to ask the assessing authority to withdraw the assessment.

Signed:

Name:

For and on behalf of: BLANKFORT INC.

24 Limitations

The following limitations apply to this assessment:

- 1) This assessment addresses itself solely to the elements and subjects discussed and does not cover any other criteria. All other details not specifically referred to should remain as tested or assessed.
- 2) This assessment is issued on the basis of test data and information to hand at the time of issue. If contradictory evidence becomes available, Exova Warringtonfire reserves the right to withdraw the assessment unconditionally, but not retrospectively.
- 3) This assessment has been carried out in accordance with Fire Test Study Group Resolution No. 82: 2001.
- 4) Opinions and interpretations expressed herein are outside the scope of UKAS accreditation.
- 5) This assessment relates only to those aspects of design, materials and construction that influence the performance of the element(s) under fire resistance test conditions. It does not purport to be a complete specification ensuring fitness for purpose and long-term serviceability. It is the responsibility of the client to ensure that the element conforms to recognised good practice in all other respects and that, with the incorporation of the guidance given in this assessment, the element is suitable for its intended purpose.

25 Validity

- 1) The assessment is initially valid until 12th November 2022, after which time it must be submitted to Exova Warringtonfire for technical re-appraisal and revalidation.
- 2) This assessment report is not valid unless it incorporates the declaration given in Section 23, duly signed by the applicant.

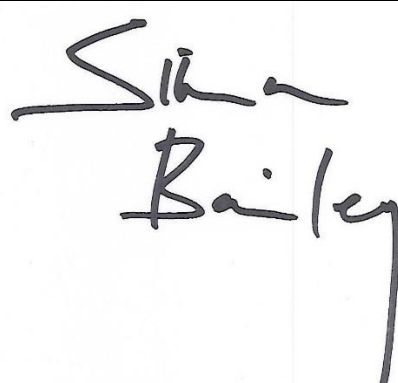
Signature :		
Name:	Dr K D S Towler	Simon Bailey
Title:	Senior Product Assessor	Principal Technical Officer

Appendix A Performance Data

Blankfort 60 Primary Data

Report No.	Configuration	Leaf Size (mm)	Test Standard	Performance (mins)
RF95119	A: ULSASD	2440 x 915 x 54	BS 476: Part 22: 1987	73
	B: ULSASD	2135 x 915 x 54		69
BTC 10971F	ULSASD	2440 x 915 x 54	BS 476: Part 22: 1987	64
RF00005	ULSASD	2135 x 915 x 54	BS 476: Part 22: 1987	64
RF00117	ULSASD	2044 x 886 x 54	BS 476: Part 22: 1987	66
RF96073	DADD	2138 x 916 x 54	BS 476: Part 22: 1987	64
RF11061 (Post-formed Acrovyn)	B: ULSADD	2100 x 900/300 x 54	BS 476: Part 22: 1987	68
CFR1010081	A: ULSASD	2151 x 924 x 54	BS EN 1634-1	65
	B: ULSASD	2443 x 923 x 54		63

Blankfort 60+ Primary Data

Report No.	Configuration	Leaf Size (mm)	Test Standard	Performance (mins)
RF00122	A: ULSASD	2439 x 915 x 54	BS 476: Part 22: 1987	63
	B: ULSASD	2135 x 915 x 54		66
RF01052/A	ULSADD+OP	2396 x 850 x 54	BS 476: Part 22: 1987	63
RF08080 (Top & bottom rail-Blankfort 60+ design)	ULSADD	2750 x 915/915 x 54	BS 476: Part 22: 1987	65
RF11007	ULSADD	2135 x 890/290 x 54	BS 476: Part 22: 1987	65
RF11061 (Post-formed Acrovyn)	B: ULSADD	2100 x 900/300 x 54	BS 476: Part 22: 1987	68
RF08081 (Glazing)	A: ULSASD	2135 x 917 x 54	BS EN 1634-1	56*
	B: ULSASD	2440 x 1220 x 54		51

* The data generated by doorset A in test RF08081 has been used to justify larger glazed apertures when using Pilkington's 10mm Pyrodur fitted with Sealmaster's Fireglaze system. The failure occurred at the top closing corner of the doorset with no indication of any failures of the glass or glazing system upon termination of the test. The 7% shortfall in performance has been attributed to the known severity of the BS EN 1634-1 Test Standard.

Supplementary Data

Report No.	Configuration	Leaf Size (mm)	Test Standard	Performance (mins)
A07051 Rev. B (Lorient Palusol & Type 617 seals)	Various	Various	BS 476: Part 22: 1987	30 & 60
IF09029 (EXOVA WARRINGTONFIRE test-200mm lengths of intumescent)	Bespoke test sample	1170 x 1170 test sample	BS 476: Part 22: 1987	43*
RF05035 (23mm Pyrostop)	A: ULSASD	2135 x 1040 x 54	BS EN 1634-1	66
RF05036 (60-10 Pyrodur in doorset and screen assembly)	A: ULSASD with glazed screen assembly	2133 x 1037 x 54	BS EN 1634-1	64
RF05126 (25mm Pyrobel)	A: ULSASD	2135 x 915 x 54	BS EN 1634-1	59**
WF140704 (Small scale test on Dorma ITS96)	DASD	994 x 998 x 54	BS 476: Part 22: 1987	58***
IF13095 Rev. A (CS Group Acrovyn Wrap)	Bespoke test sample	1400x900/300x57	BS 476: Part 20/22: 1987	60
RF01114 (Therm-A-Seal)	B: ULSASD	2135 x 915 x 53	BS 476: Part 22: 1987	66
RF13179	ULSADD	2145 x 936 x 54	BSEN 1634-1	Integrity 61 Insulation 59

Notes:

* Test IF09029 was carried out to compare the performance of short lengths of intumescent seals with continuous lengths. The junction tested was between a hardwood and softwood interface and as such would not be expected to provide 60 minutes fire resistance. However, the results of the test did adequately demonstrate that short lengths of intumescent seals can be used in place of continuous lengths subject to the constraints specified within this global assessment.

** The failure at 59 minutes was attributable to the leaf to frame junction. No failure directly attributable to the glass prior to test termination at 66 minutes.

*** The failure at 58 minutes was attributable to insufficient perimeter intumescent material at the head of the leaf. The failure was remote from the closer and the closer did not fail integrity until 62 minutes. It is a requirement of this assessment when using the Dorma ITS 96 that a minimum of 1No. 20x4mm seal is used centrally in the frame reveal in conjunction with 2No. 10x4mm seals running continuously past the slide arm in the frame reveal for the full width of the leaf, in conjunction with the proprietary intumescent pack supplied by the manufacturer (see section 15.1.2).

Appendix B

Proprietary 60 Minute Glazing Systems

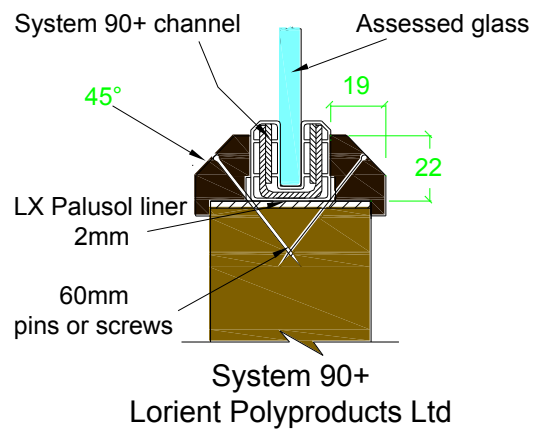
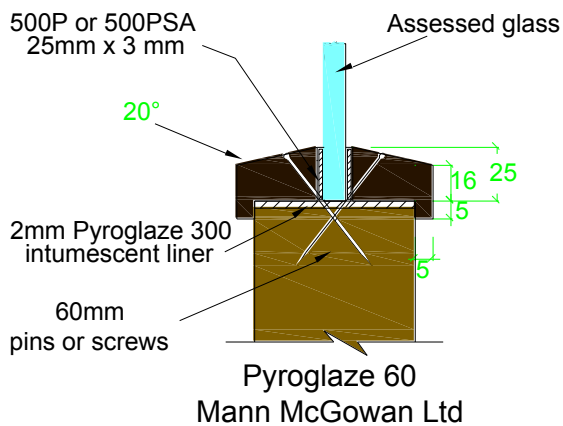
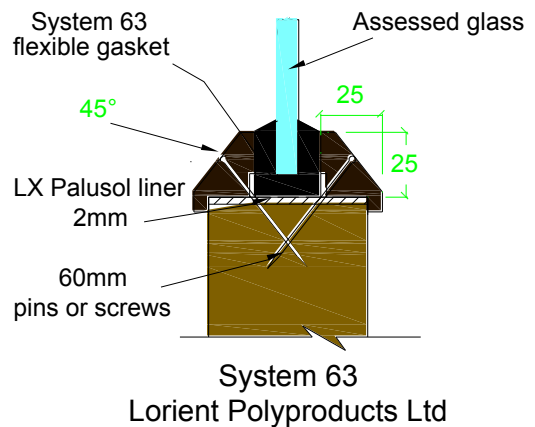
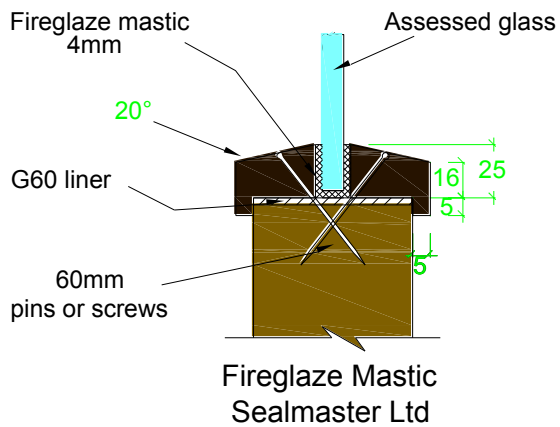
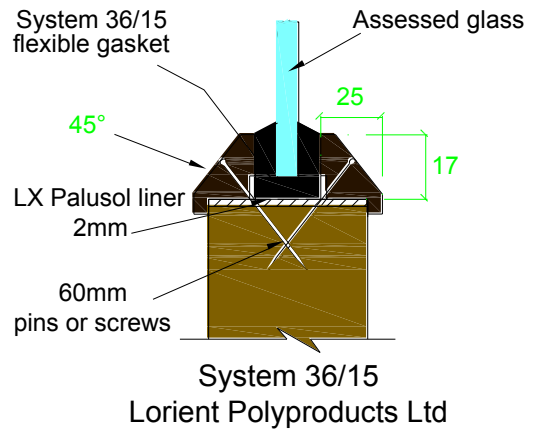
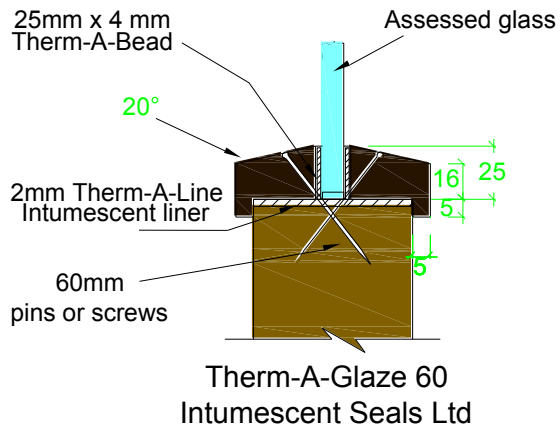

Vetrotech 60 Minute Glazing System

Assessed Square Glazing Bead Profiles

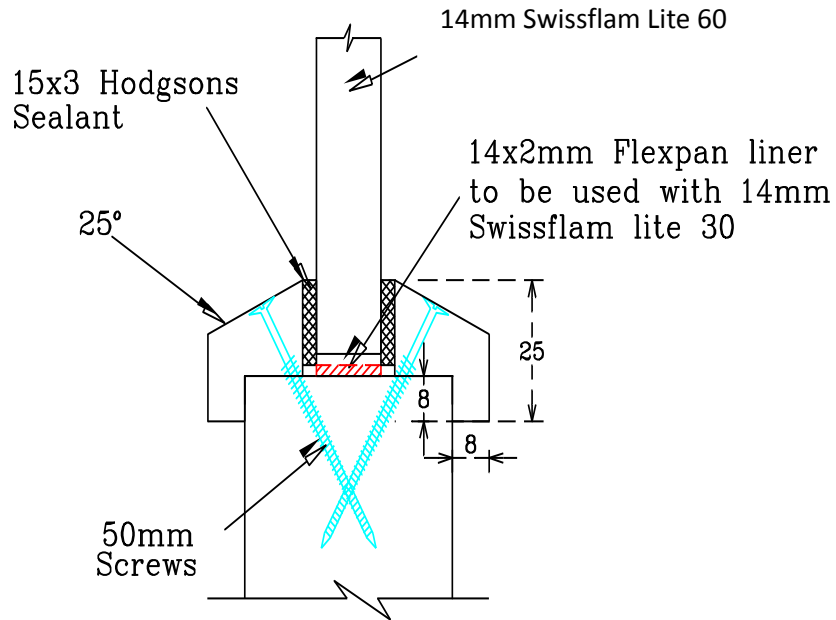

(The following square bead profile may be used as an alternative to the splayed beads detailed above - refer to section 6 for glazing system and glass restrictions).

To finish flush with the leaf face

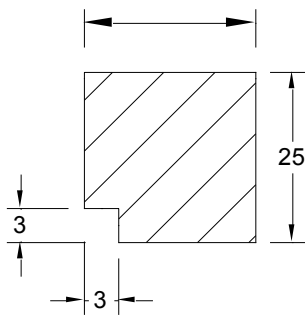

Suited to glass thickness

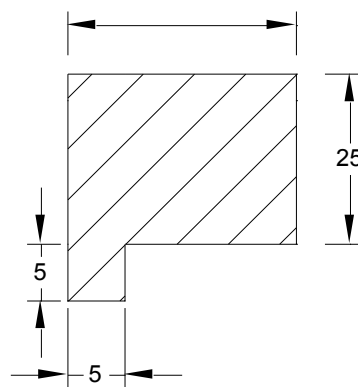

To finish flush with the leaf face

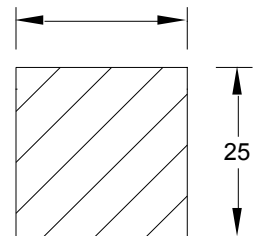

Appendix C

Revisions

Rev.	EXOVA WARRINGTONFIRE Ref.	Date	Description
A	12254	12/11/12	Revalidation with further five years validity. Inclusion of post-formed CS Group Acrovyn based on Chilt/RF11061. Change of address on front page.
B	14198	14/11/14	Update to include indicative test referenced IF13095 covering CS Group Acrovyn cladding the whole leaf. Additional hinge specification has been clarified. Inclusion of fire test referenced RF01114 to cover Therm-A-Seal from Intumescent Seals Ltd. included on a new data sheet. The validity period has been maintained.
C	CNA/F15035	03/02/15	Factual corrections to 3 data sheets. Replacement of missing footers. Re-formatted data sheets to ensure the document reads correctly when PDF'd.
D	CNA/F15080	24/03/15	Correction to hinge position section, update of glazing pin specification section
E	391846	12/11/2017	5 year technical review and update into Exova Warrington format.

Appendix D

Data Sheets for:

Blankfort Inc.

Blankfort 60 & Blankfort 60+ Doorsets

60 Minute Fire Resisting Doorsets

Blankfort 60 – Chipboard Faces – Reduced Intumescent
Latched & Unlatched, Single & Double Acting, Single Doorsets

	Configuration		Height (mm)	Width (mm)
Leaf Sizes	LSASD & ULSASD & DASD	Maximum Leaf Size	2135	x 915
Max. Overpanel Height (mm)		Transomed	2000	
Glazing		Max. Glazed Area	0.72m ² (For 1.1m ² see section 6 for details)	
		Approved Systems	See section 6 and appendix B	
Frame Specification		Min. Section (mm)	70 x 32	70 x 30
		Material	Hardwood	MDF
		Min. Density (kg/m ³)	640	720
INTUMESCENT MATERIALS: Palusol, Type 617, 500P, Pyroplex				
HEAD: 1No. 25 x 4mm strip centrally fitted in the leaf edge or frame reveal. Alternatively, 2No. 15 x 4mm strips centrally fitted 5mm either side of the centreline.				
JAMBS & OVERPANEL: 1No. 25 x 4mm strip centrally fitted in the leaf edge or frame reveal. Alternatively, 2No. 15 x 4mm strips centrally fitted 5mm either side of the centreline.				
HARDWARE PROTECTION: See section 11.				

Maximum Door Leaf Size

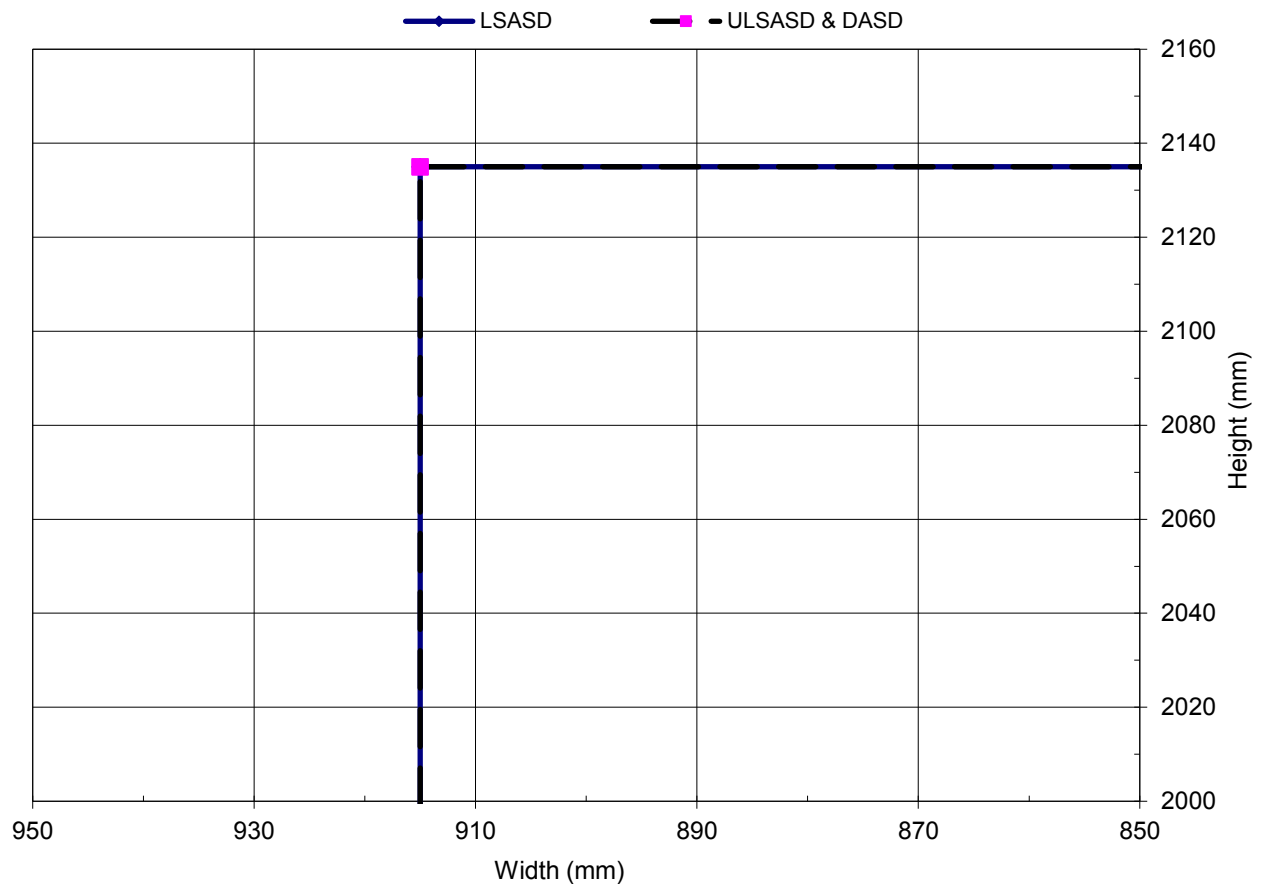

Blankfort 60 – Chipboard Faces Latched & Unlatched, Single & Double Acting, Single Doorsets

	Configuration		Height (mm)		Width (mm)
Leaf Sizes	LSASD	From:	2440	x	970
		To:	2571	x	915
	ULSASD & DASD	From:	2440	x	945
		To:	2521	x	915
Max. Overpanel Height (mm)		Transomed	2000		
Glazing		Max. Glazed Area	0.72m ² (For 1.1m ² see section 6 for details)		
		Approved Systems	See section 6 and appendix B		
Frame Specification		Min. Section (mm)	70 x 32	70 x 30	
		Material	Hardwood	MDF	
		Min. Density (kg/m ³)	640	720	
INTUMESCENT MATERIALS: Palusol, Type 617, 500P, Pyroplex					
HEAD: 1No. 38 x 4mm strip centrally fitted in the leaf edge or frame reveal.					
JAMBS & OVERPANEL: 2No. 15 x 4mm strips centrally fitted 5mm either side of the centreline in the leaf edge or frame reveal.					
HARDWARE PROTECTION: See section 11.					

Maximum Door Leaf Size

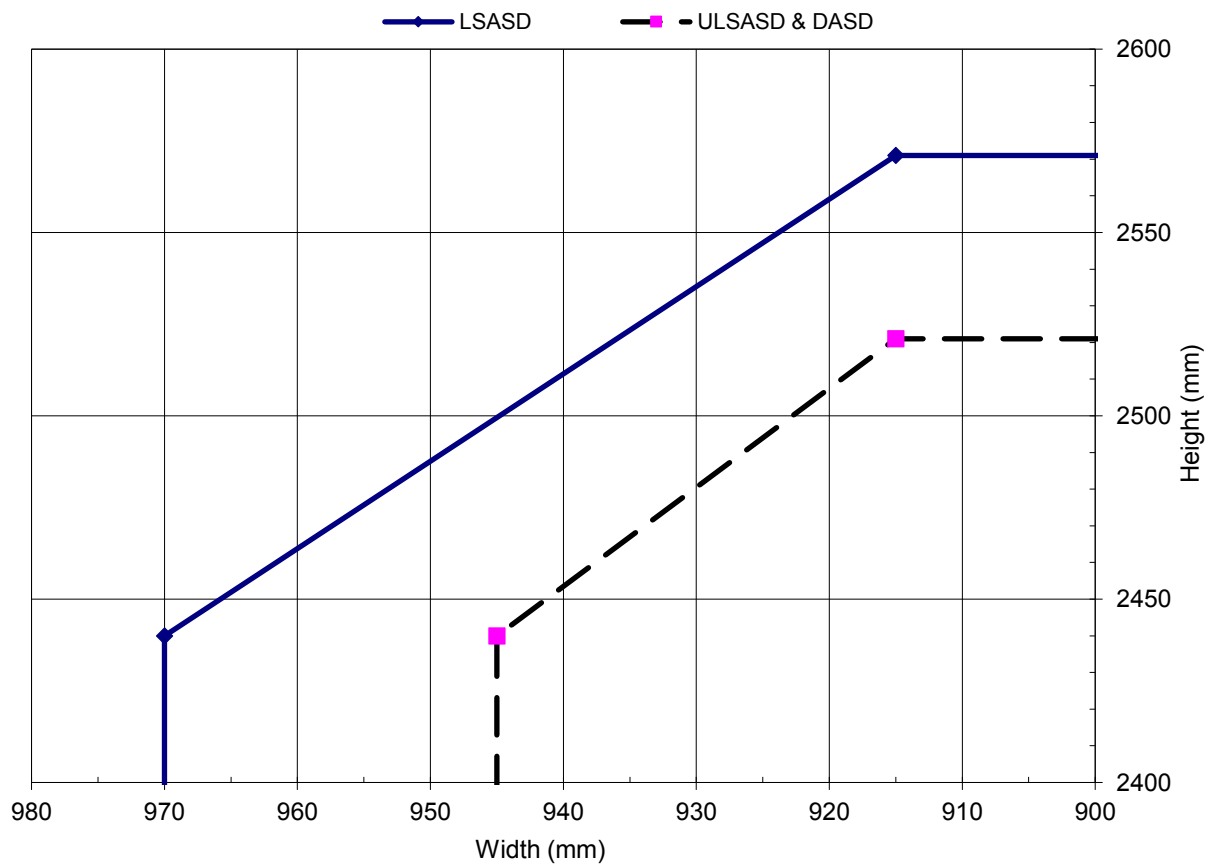

Blankfort 60 – MDF Faces

Latched & Unlatched, Single & Double Acting, Single Doorsets

	Configuration		Height (mm)	Width (mm)
Leaf Sizes	LSASD	From:	2135	x 970
		To:	2255	x 915
	ULSASD & DASD	From:	2135	x 945
		To:	2205	x 915
Max. Overpanel Height (mm)	Transomed	2000		
Glazing	Max. Glazed Area	0.72m ² (For 1.1m ² see section 6 for details)		
	Approved Systems	See section 6 and appendix B		
Frame Specification	Min. Section (mm)	70 x 32	70 x 30	
	Material	Hardwood	MDF	
	Min. Density (kg/m ³)	640	720	

INTUMESCENT MATERIALS: Pyroplex

HEAD: 1No. 38 x 4mm strip centrally fitted in the leaf edge or frame reveal.

JAMBS & OVERPANEL: 1No. 38 x 4mm strip centrally fitted in the leaf edge or frame reveal.

HARDWARE PROTECTION: See section 11.

Maximum Door Leaf Size

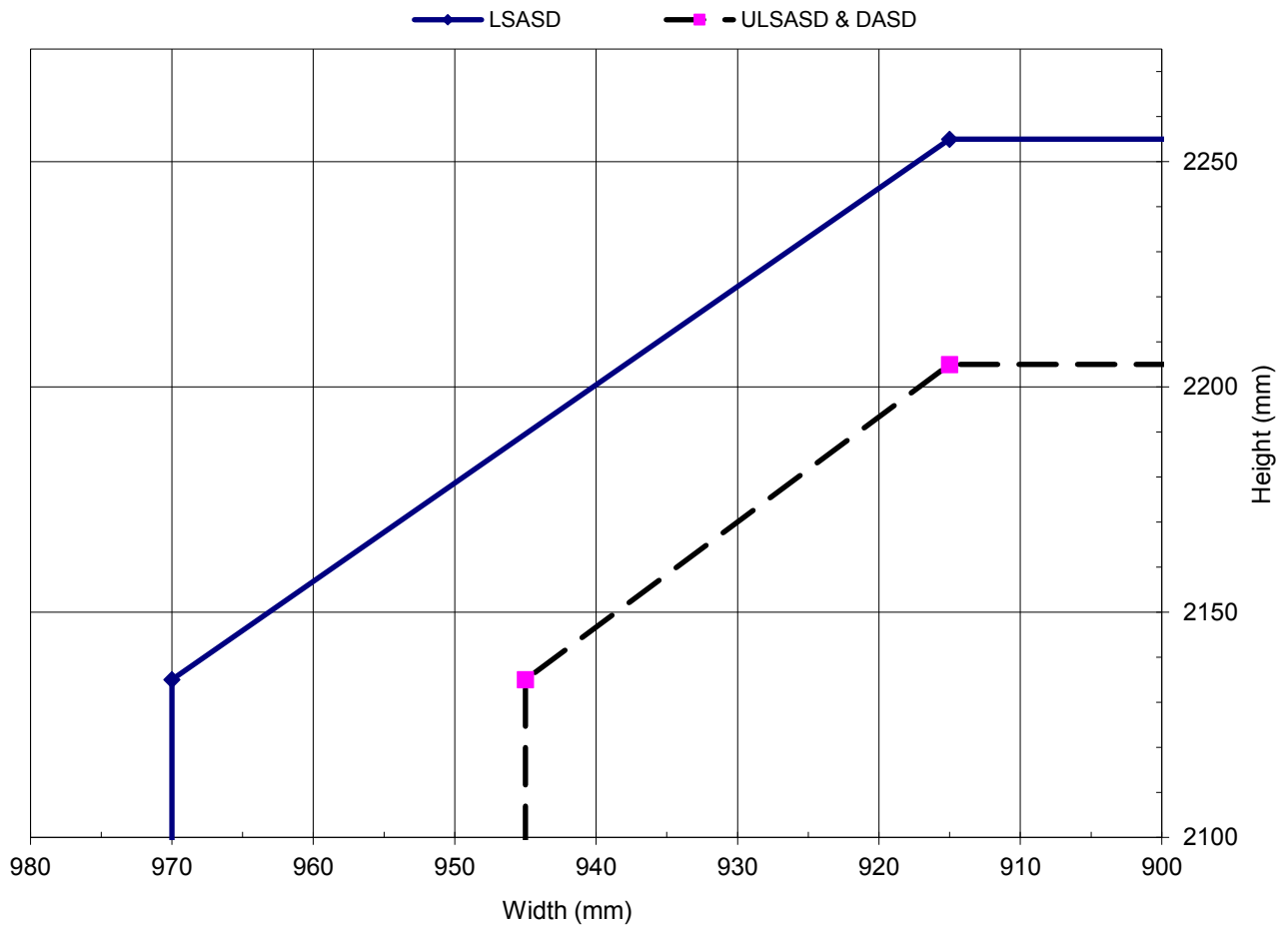

Blankfort 60 & Blankfort 60+ – Therm-A-Seal
Latched & Unlatched, Single & Double Acting, Single Doorsets

	Configuration		Height (mm)		Width (mm)
Leaf Sizes	LSASD	From:	2135	x	986
		To:	2292	x	915
	ULSASD & DASD	From:	2135	x	961
		To:	2242	x	915
Max. Overpanel Height (mm)		Transomed	2000		
Glazing		Max. Glazed Area	0.72m ² (For 1.1m ² see section 6 for details)		
		Approved Systems	See section 6 and appendix B		
Frame Specification		Min. Section (mm)	70 x 32		70 x 30
		Material	Hardwood		MDF
		Min. Density (kg/m ³)	640		720

INTUMESCENT MATERIALS: Therm-A-Seal

HEAD: 2No. 15 x 4mm strips centrally fitted 5mm either side of the centreline in the frame reveal.

JAMBS & OVERPANEL: 2No. 15 x 4mm strips centrally fitted 5mm either side of the centreline in the frame reveal.

HARDWARE PROTECTION: See section 11.

Maximum Door Leaf Size

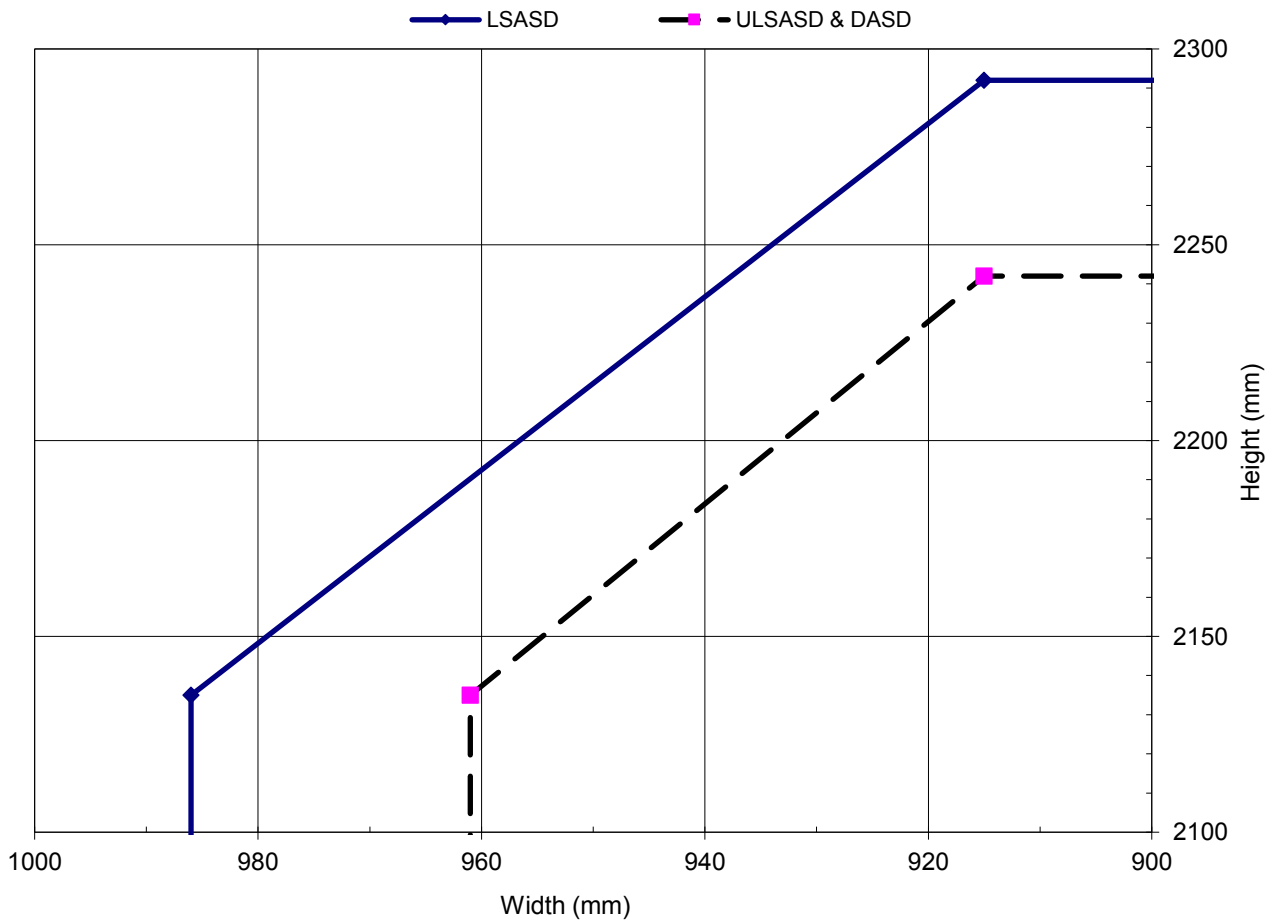

Blankfort 60 – Chipboard Faces

Latched & Unlatched, Single & Double Acting, Double Doorsets

	Configuration		Height (mm)		Width (mm)
Leaf Sizes	LSADD	From:	2138	x	971
		To:	2259	x	916
	ULSADD & DADD	From:	2138	x	946
		To:	2209	x	916
Max. Overpanel Height (mm)		Transomed	1500		
Glazing		Max. Glazed Area	0.72m ² (For 1.1m ² see section 6 for details)		
		Approved Systems	See section 6 and appendix B		
Frame Specification		Min. Section (mm)	70 x 32	70 x 30	
		Material	Hardwood	MDF	
		Min. Density (kg/m ³)	640	720	

INTUMESCENT MATERIALS: Palusol, Type 617, 500P, Pyroplex

HEAD: 1No. 38 x 4mm strip centrally fitted in the leaf edge or frame reveal.

MEETING EDGES:

Square: 2No. 15 x 4mm strips centrally fitted 5mm either side of the centreline in one leaf edge only.

JAMBS & OVERPANEL: 1No. 38 x 4mm strip centrally fitted in the leaf edge or frame reveal.

HARDWARE PROTECTION: See section 11.

Maximum Door Leaf Size

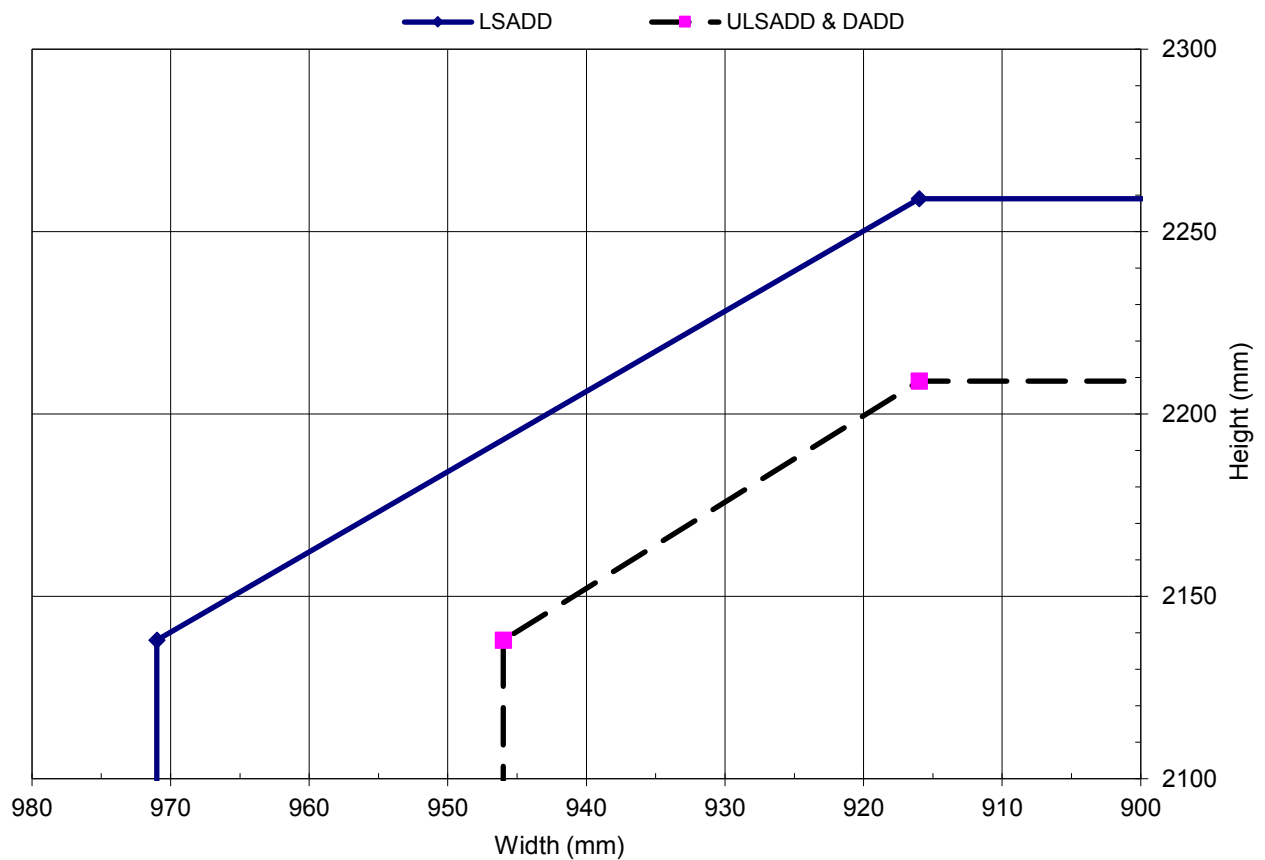

Blankfort 60+ – Reduced Intumescents
Latched & Unlatched, Single & Double Acting, Single Doorsets

Configuration	Height (mm)		Width (mm)	
	From:	2135	x	1016
To:	2363	x	915	
Leaf Sizes	From:	2135	x	991
	To:	2313	x	915
Max. Overpanel Height (mm)	Transomed	2000		
Glazing	Max. Glazed Area	0.72m ² (For 1.1m ² see section 6 for details)		
	Approved Systems	See section 6 and appendix B		
Frame Specification	Min. Section (mm)	70 x 32	70 x 30	
	Material	Hardwood	MDF	
	Min. Density (kg/m ³)	640	720	

INTUMESCENT MATERIALS: 500P

HEAD: 2No. 15 x 4mm strips centrally fitted 5mm either side of the centreline in the leaf edge or frame reveal.

JAMBS & OVERPANEL: 2No. 15 x 4mm strips centrally fitted 5mm either side of the centreline in the leaf edge or frame reveal.

HARDWARE PROTECTION: See section 11.

Maximum Door Leaf Size

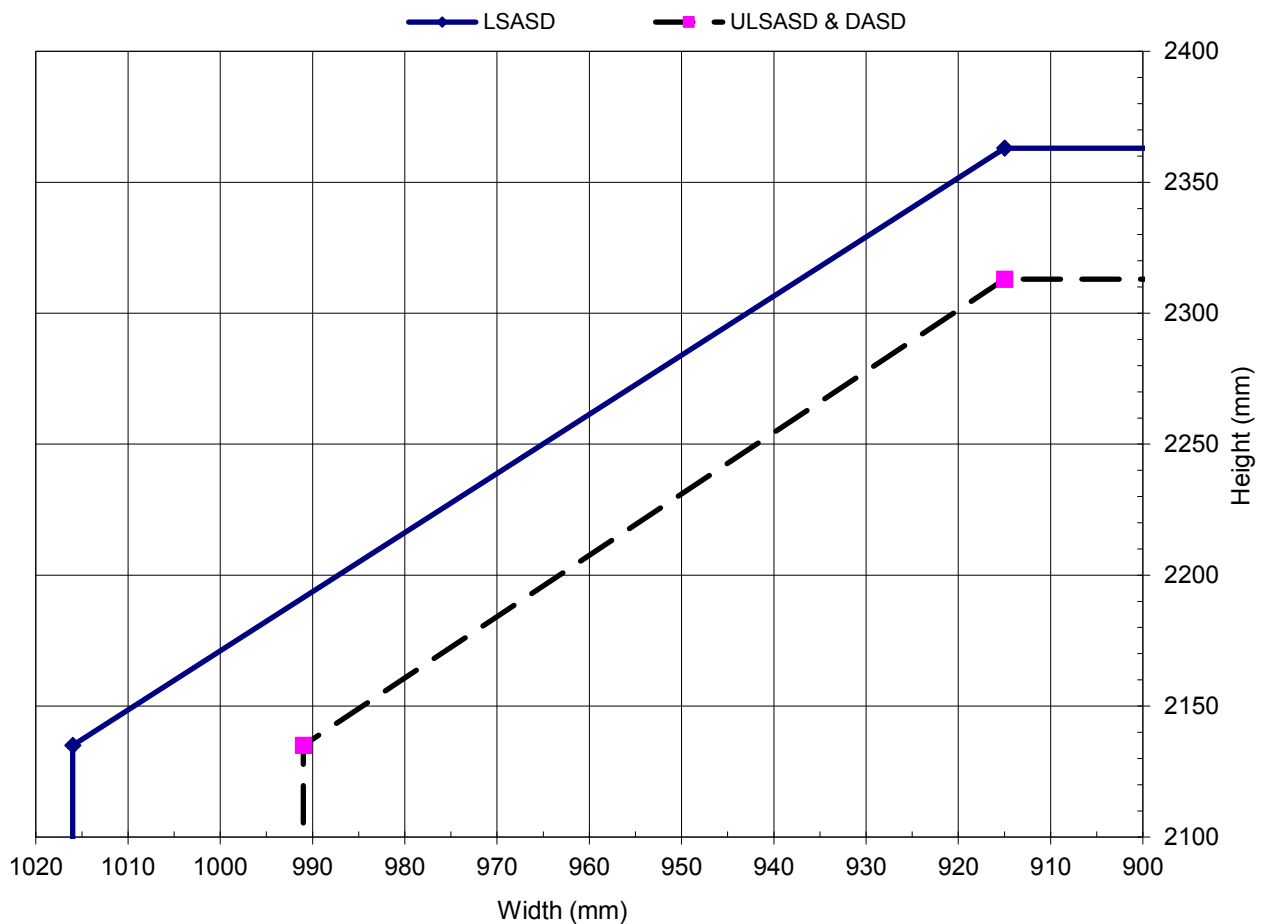

Blankfort 60+

Latched & Unlatched, Single & Double Acting, Single Doorsets

	Configuration		Height (mm)		Width (mm)
Leaf Sizes	LSASD	From:	2396	x	1046
		To:	2806	x	850
	ULSASD & DASD	From:	2396	x	1021
		To:	2756	x	850
Max. Overpanel Height (mm)		Transomed	2000		
Glazing		Max. Glazed Area	0.72m ² (For 1.1m ² see section 6 for details)		
		Approved Systems	See section 6 and appendix B		
Frame Specification		Min. Section (mm)	70 x 32	70 x 30	
		Material	Hardwood	MDF	
		Min. Density (kg/m ³)	640	720	

INTUMESCENT MATERIALS: 500P

HEAD: 1No. 38 x 4mm strip centrally fitted in the leaf edge or frame reveal.

JAMBS & OVERPANEL: 2No. 15 x 4mm strips centrally fitted 5mm either side of the centreline in the leaf edge or frame reveal.

HARDWARE PROTECTION: See section 11.

Maximum Door Leaf Size

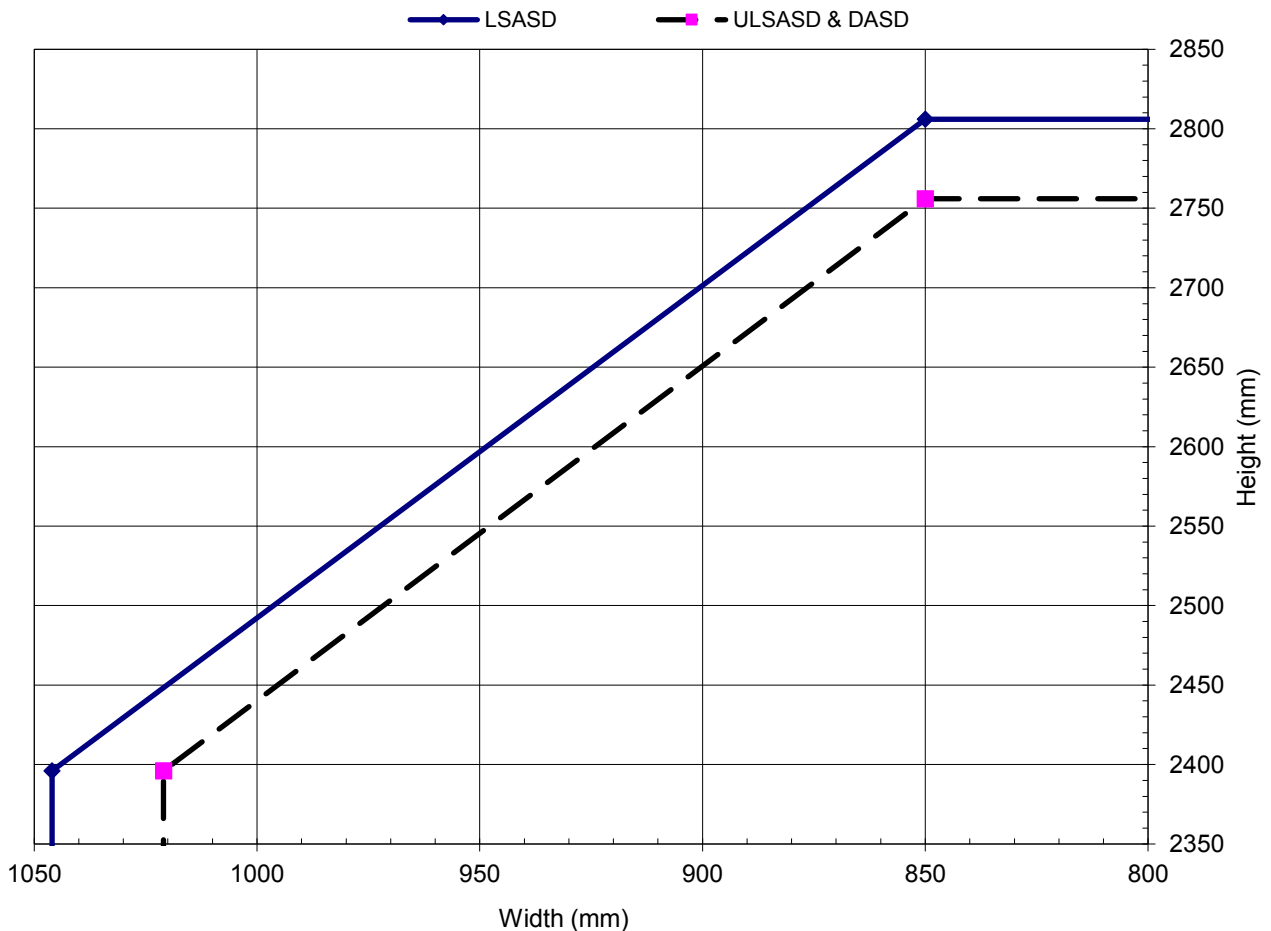

Blankfort 60+

Latched & Unlatched, Single & Double Acting, Single Doorsets + Overpanels

	Configuration		Height (mm)		Width (mm)	
Leaf Sizes	LSASD+OP	From:	2396	x	996	
		To:	2706	x	850	
	ULSASD+OP & DASD+OP	From:	2396	x	971	
		To:	2656	x	850	
Max. Overpanel Height (mm)			2000			
Glazing	Max. Glazed Area		0.72m ² (For 1.1m ² see section 6 for details)			
	Approved Systems		See section 6 and appendix B			
Frame Specification	Min. Section (mm)		70 x 32		70 x 30	
	Material		Hardwood		MDF	
	Min. Density (kg/m ³)		640		720	

INTUMESCENT MATERIALS: 500P

HEAD:

Rebated: 1No. 20 x 4mm strip centrally fitted in the rebate of the leaf head and 1No. 20 x 4mm strip centrally fitted in the bottom edge of the overpanel.

Square: 1No. 38 x 4mm strip centrally fitted in the leaf head or bottom of the overpanel.

JAMBS & OVERPANEL: 2No. 15 x 4mm strips centrally fitted 5mm either side of the centreline in the leaf edge or frame reveal.

HARDWARE PROTECTION: See section 11.

Maximum Door Leaf Size

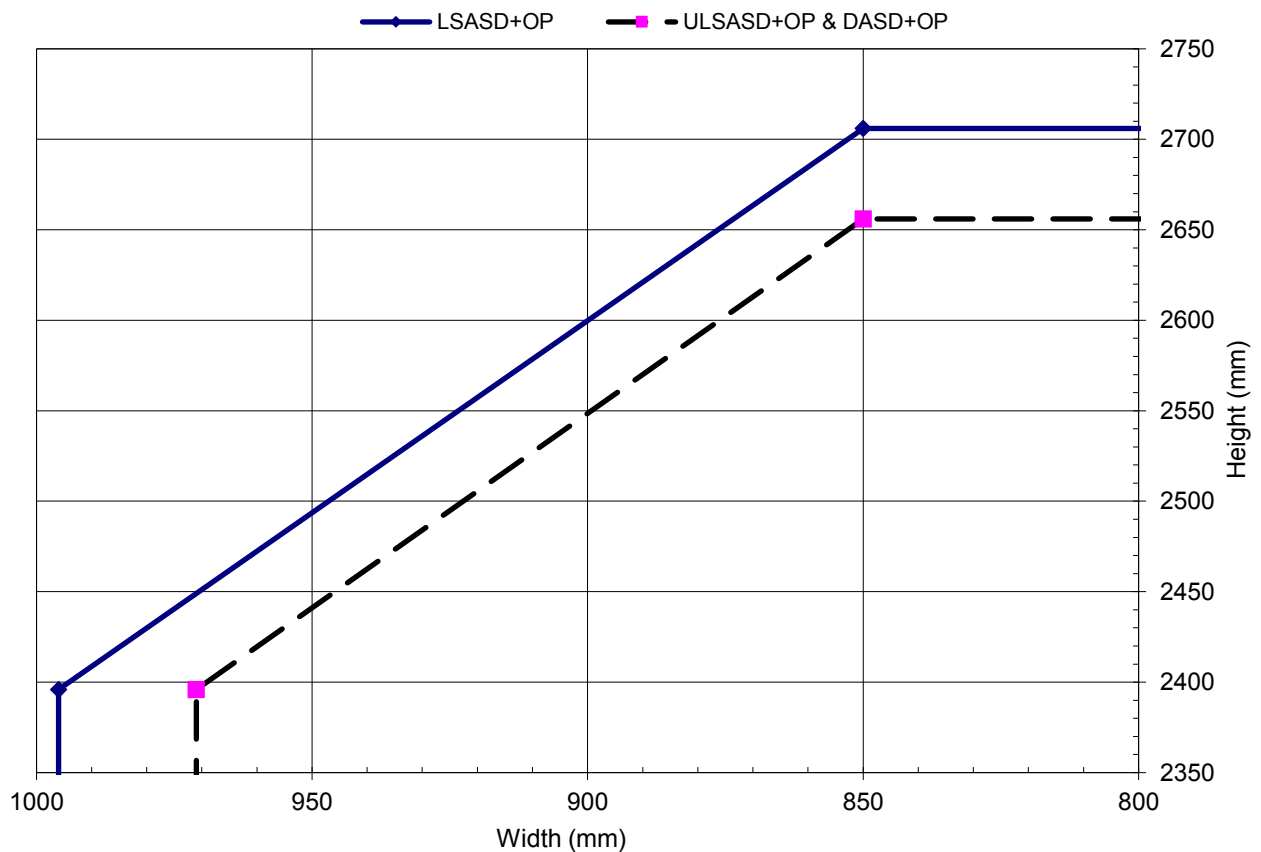

Blankfort 60+

Latched & Unlatched, Single & Double Acting, Double Doorsets

	Configuration		Height (mm)		Width (mm)
Leaf Sizes	LSADD	From:	2396	x	946
		To:	2606	x	850
	ULSADD & DADD	From:	2396	x	921
		To:	2556	x	850
Max. Overpanel Height (mm)	Transomed	1500			
Glazing	Max. Glazed Area	0.72m ² (For 1.1m ² see section 6 for details)			
	Approved Systems	See section 6 and appendix B			
Frame Specification	Min. Section (mm)	70 x 32		70 x 30	
	Material	Hardwood		MDF	
	Min. Density (kg/m ³)	640		720	

INTUMESCENT MATERIALS: 500P

HEAD: 1No. 38 x 4mm strip centrally fitted in the leaf edge or frame reveal.

MEETING EDGES:

Square: 2No. 15 x 4mm strips centrally fitted 5mm either side of the centreline in one leaf edge only.

JAMBS & OVERPANEL: 2No. 15 x 4mm strips centrally fitted 5mm either side of the centreline in the leaf edge or frame reveal.

HARDWARE PROTECTION: See section 11.

Maximum Door Leaf Size

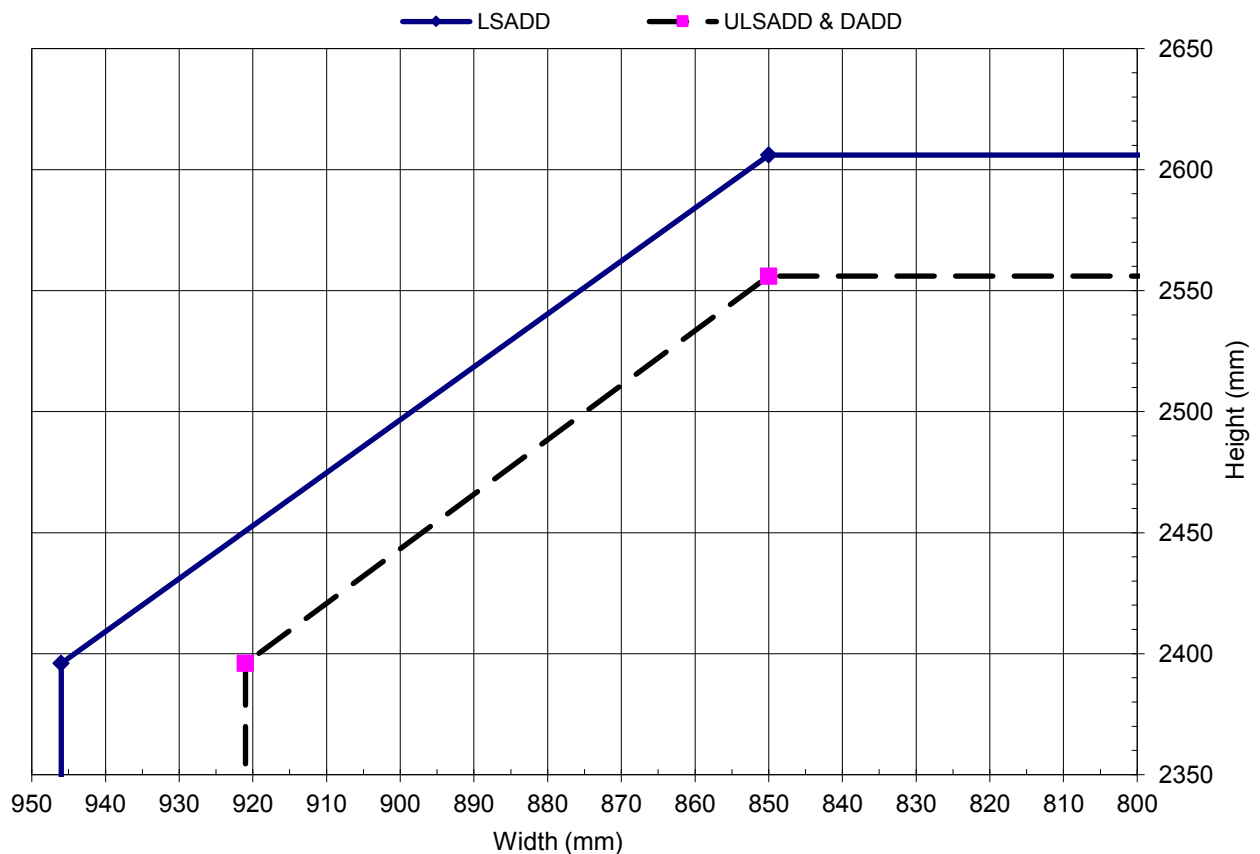

Blankfort 60+

Latched & Unlatched, Single & Double Acting, Double Doorsets + Overpanels

Leaf Sizes	Configuration		Height (mm)		Width (mm)	
			From:	To:	x	x
Leaf Sizes	LSADD+OP	From:	2396	x	896	
		To:	2506	x	850	
Leaf Sizes	ULSADD+OP & DADD+OP	From:	2396	x	871	
		To:	2456	x	850	
Max. Overpanel Height (mm)			1500			
Glazing			Max. Glazed Area		0.72m ² (For 1.1m ² see section 6 for details)	
			Approved Systems		See section 6 and appendix B	
Frame Specification			Min. Section (mm)		70 x 32	70 x 30
			Material		Hardwood	MDF
			Min. Density (kg/m ³)		640	720

INTUMESCENT MATERIALS: 500P

HEAD:

Square: 1No. 38 x 4mm strip centrally fitted in the leaf edge or bottom of the overpanel.

Rebated: 1No. 20 x 4mm strip centrally fitted in the rebate of the leaf head and 1No. 20 x 4mm strip centrally fitted in the bottom edge of the overpanel.

MEETING EDGES:

Square: 2No. 15 x 4mm strips centrally fitted 5mm either side of the centreline in one leaf edge only.

JAMBS & OVERPANEL: 2No. 15 x 4mm strips centrally fitted 5mm either side of the centreline in the leaf edge or frame reveal.

HARDWARE PROTECTION: See section 11.

Maximum Door Leaf Size

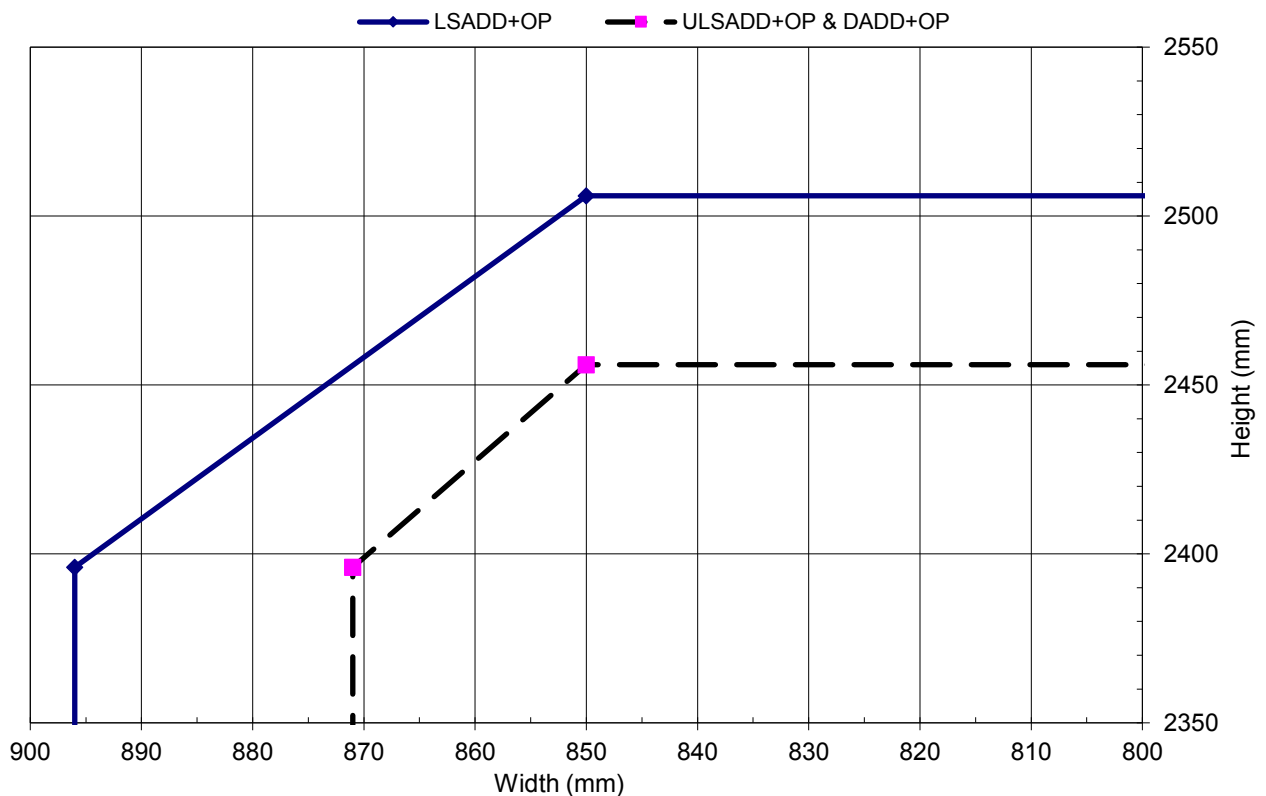

Blankfort 60+ – Fitted with a Top & Bottom Rail
Latched & Unlatched, Single & Double Acting, Single Doorsets

	Configuration		Height (mm)	Width (mm)
Leaf Sizes	LSASD	From:	2750	x 1028
		To:	3015	x 915
	ULSASD & DASD	From:	2750	x 1003
		To:	2965	x 915
Max. Overpanel Height (mm)	Transomed	2000		
Glazing	Max. Glazed Area	0.72m ² (For 1.1m ² see section 6 for details)		
	Approved Systems	See section 6 and appendix B		
Frame Specification	Min. Section (mm)	70 x 32	70 x 30	
	Material	Hardwood	MDF	
	Min. Density (kg/m ³)	640	720	

INTUMESCENT MATERIALS: Type 617

HEAD: 1No. 15 x 4mm strip centrally fitted in the leaf head and 2No. 15 x 4mm strips centrally fitted 5mm either side of the centreline in the frame reveal.

JAMBS & OVERPANEL: 2No. 15 x 4mm strips centrally fitted 5mm either side of the centreline in the leaf edge or frame reveal.

HARDWARE PROTECTION: See section 11.

Maximum Door Leaf Size

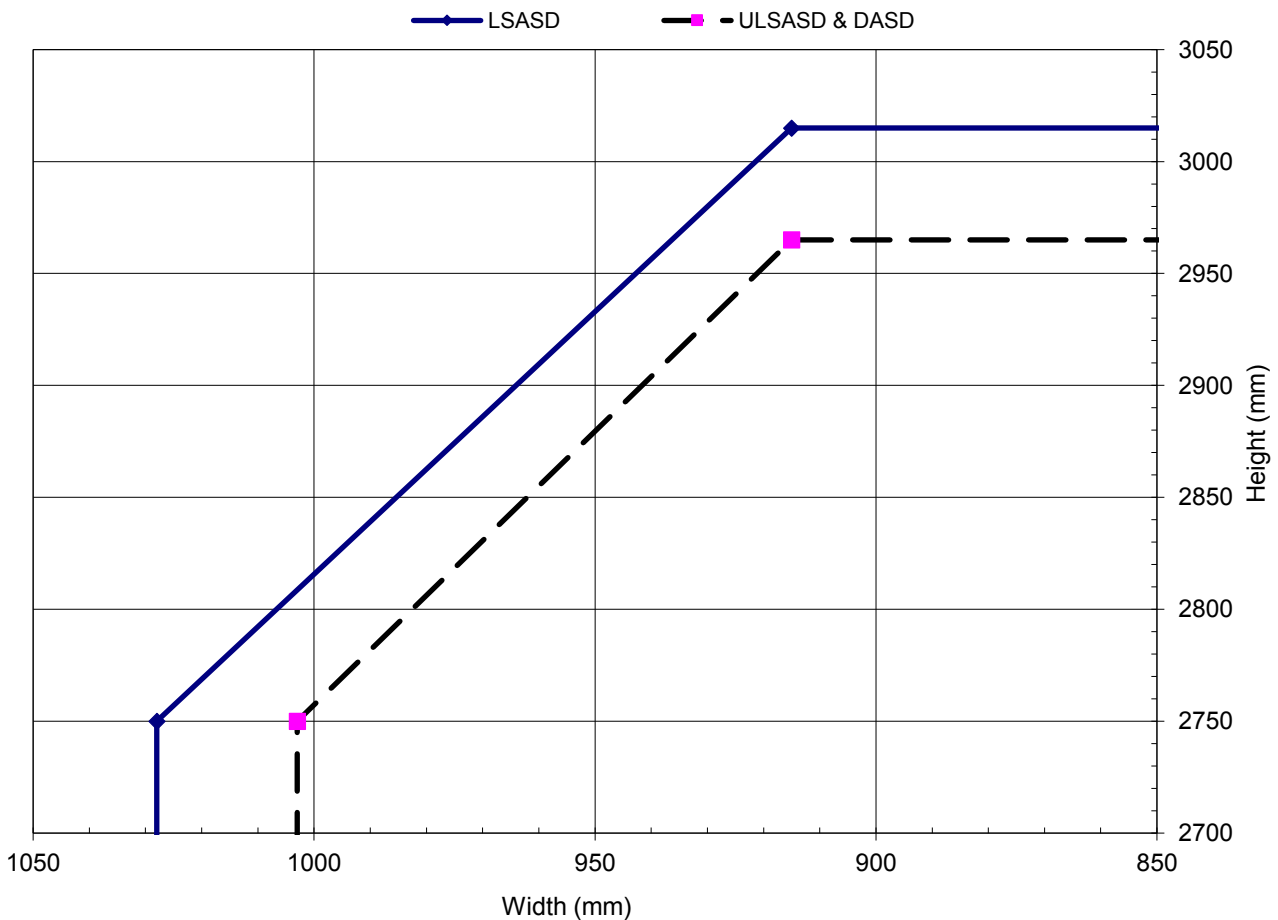

Blankfort 60+ – Fitted with a Top & Bottom Rail
Latched & Unlatched, Single & Double Acting, Double Doorsets

	Configuration		Height (mm)	Width (mm)
Leaf Sizes	LSADD	From:	2750	x 978
		To:	2915	x 915
	ULSADD & DADD	From:	2750	x 953
		To:	2865	x 915
Max. Overpanel Height (mm)	Transomed	1500		
Glazing	Max. Glazed Area	0.72m ² (For 1.1m ² see section 6 for details)		
	Approved Systems	See section 6 and appendix B		
Frame Specification	Min. Section (mm)	70 x 32	70 x 30	
	Material	Hardwood	MDF	
	Min. Density (kg/m ³)	640	720	

INTUMESCENT MATERIALS: Type 617

HEAD: 1No. 15 x 4mm strip centrally fitted in the leaf head and 2No. 15 x 4mm strips centrally fitted 5mm either side of the centreline in the frame reveal.

MEETING EDGES:

Square: 2No. 15 x 4mm strips centrally fitted 5mm either side of the centreline in one leaf edge, opposing 1No. 15 x 4mm strip centrally fitted in the opposite meeting edge.

JAMBS & OVERPANEL: 2No. 15 x 4mm strips centrally fitted 5mm either side of the centreline in the leaf edge or frame reveal.

HARDWARE PROTECTION: See section 11.

Maximum Door Leaf Size

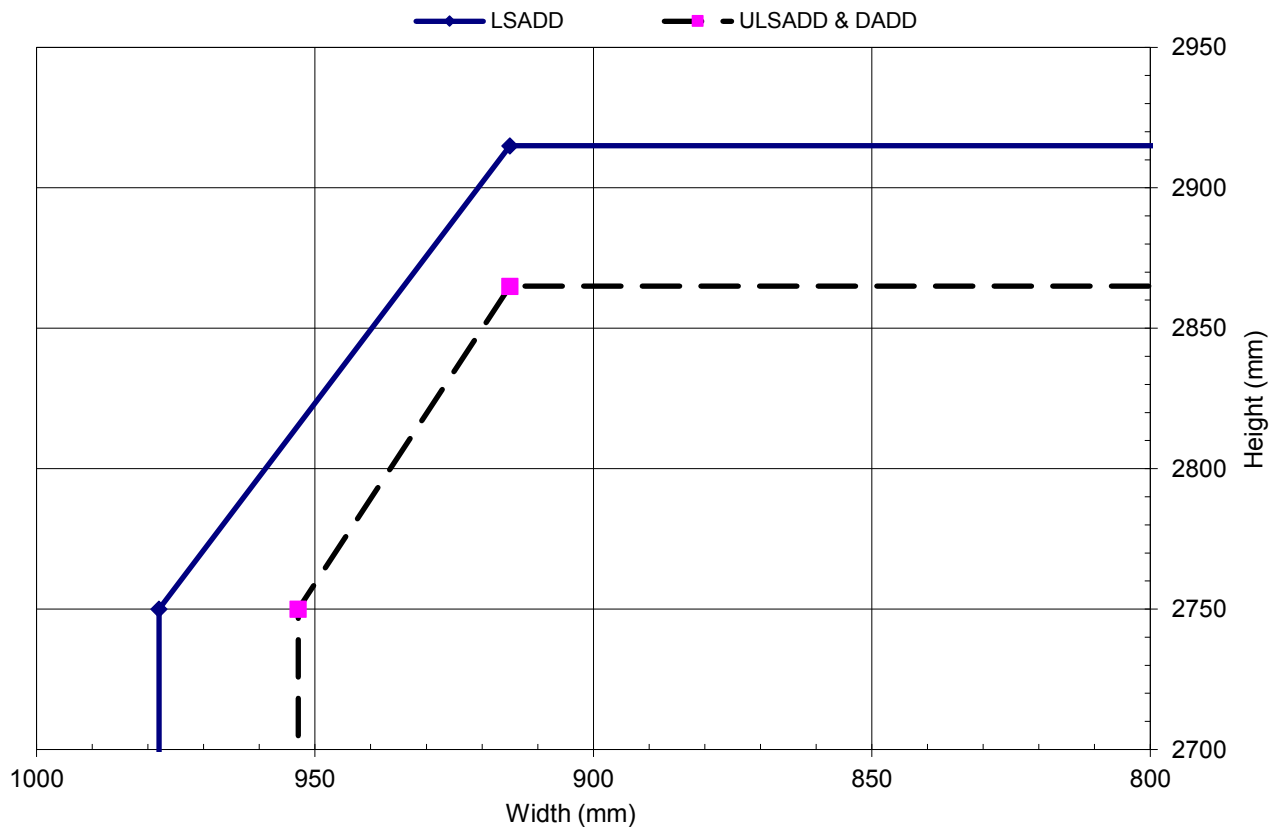

Blankfort 60 & Blankfort 60+ – Type 617
Latched & Unlatched, Single & Double Acting, Single Doorsets

	Configuration		Height (mm)	Width (mm)
Leaf Sizes	LSASD & ULSASD & DASD	From:	2120	x 1026
		To:	2300	x 915
Max. Overpanel Height (mm)	Transomed		2000	
Glazing		Max. Glazed Area	0.72m ² (For 1.1m ² see section 6 for details)	
		Approved Systems	See section 6 and appendix B	
Frame Specification		Min. Section (mm)	70 x 32	70 x 30
		Material	Hardwood	MDF
		Min. Density (kg/m ³)	640	720

INTUMESCENT MATERIALS: Type 617

HEAD: 2No. 15 x 4mm strips centrally fitted 5mm either side of the centreline in the leaf edge or frame reveal.

JAMBS & OVERPANEL: 2No. 15 x 4mm strips centrally fitted 5mm either side of the centreline in the leaf edge or frame reveal.

HARDWARE PROTECTION: See section 11.

Maximum Door Leaf Size

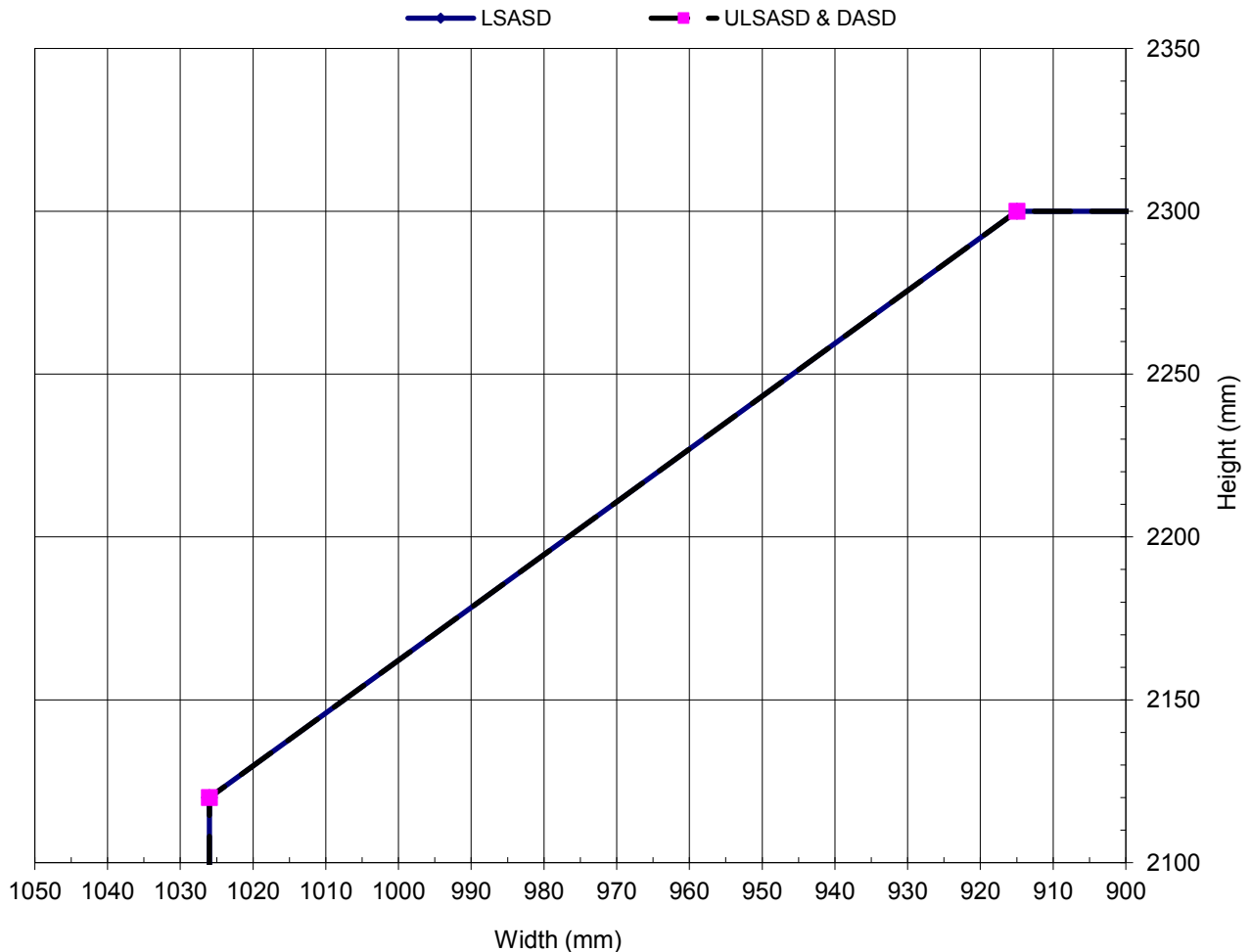

Blankfort 60 & Blankfort 60+ – Type 617
Latched & Unlatched, Single & Double Acting, Double Doorsets

Leaf Sizes	Configuration		Height (mm)		Width (mm)
			From:	To:	
	LSADD	From:	2120	x	926
		To:	2300	x	915
	ULSADD & DADD	From:	2120	x	926
		To:	2255	x	915
Max. Overpanel Height (mm)		Transomed	1500		
Glazing		Max. Glazed Area	0.72m ² (For 1.1m ² see section 6 for details)		
		Approved Systems	See section 6 and appendix B		
Frame Specification		Min. Section (mm)	70 x 32	70 x 30	
		Material	Hardwood	MDF	
		Min. Density (kg/m ³)	640	720	

INTUMESCENT MATERIALS: Type 617

HEAD: 2No. 15 x 4mm strips centrally fitted 5mm either side of the centreline in the leaf edge or frame reveal.

MEETING EDGES:

Square: 2No. 15 x 4mm strips centrally fitted 5mm either side of the centreline in one leaf edge only.

JAMBS & OVERPANEL: 2No. 15 x 4mm strips centrally fitted 5mm either side of the centreline in the leaf edge or frame reveal.

HARDWARE PROTECTION: See section 11.

Maximum Door Leaf Size

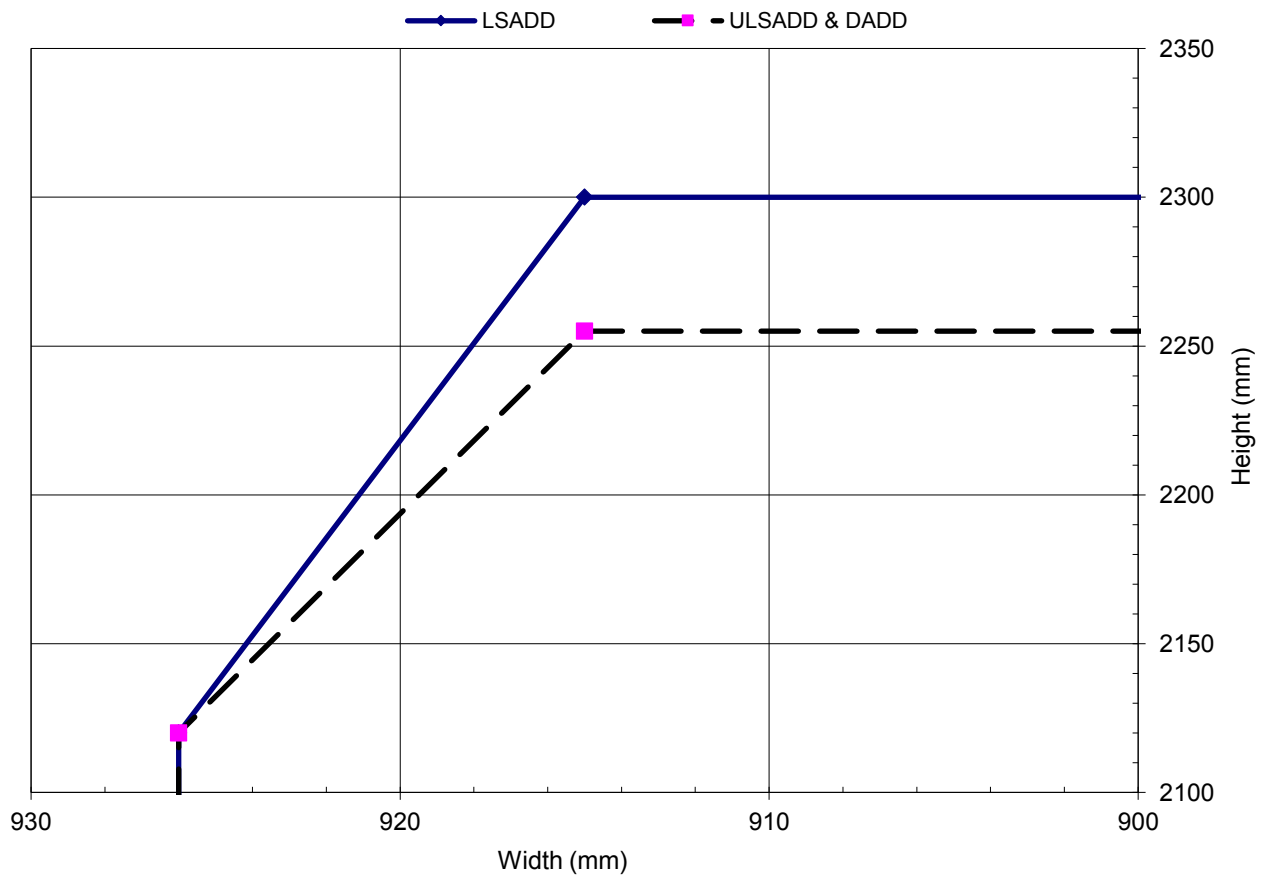

Blankfort 60 (Chipboard Faces) & Blankfort 60+ – Extended Width
Latched & Unlatched, Single & Double Acting, Single Doorsets

	Configuration		Height (mm)		Width (mm)
Leaf Sizes	LSASD	From:	2151	x	987
		To:	2290	x	924
	ULSASD & DASD	From:	2151	x	962
		To:	2240	x	924
Max. Overpanel Height (mm)		Transomed	2000		
Glazing		Max. Glazed Area	0.72m ² (For 1.1m ² see section 6 for details)		
		Approved Systems	See section 6 and appendix B		
Frame Specification		Min. Section (mm)	70 x 32	70 x 30	
		Material	Hardwood	MDF	
		Min. Density (kg/m ³)	640	720	
INTUMESCENT MATERIALS: Pyroplex					
HEAD: 2No. 20 x 4mm strips centrally fitted 4mm either side of the centreline in the leaf edge or frame reveal.					
JAMBS & OVERPANEL: 2No. 20 x 4mm strips centrally fitted 4mm either side of the centreline in the leaf edge or frame reveal.					
HARDWARE PROTECTION: See section 11.					

Maximum Door Leaf Size

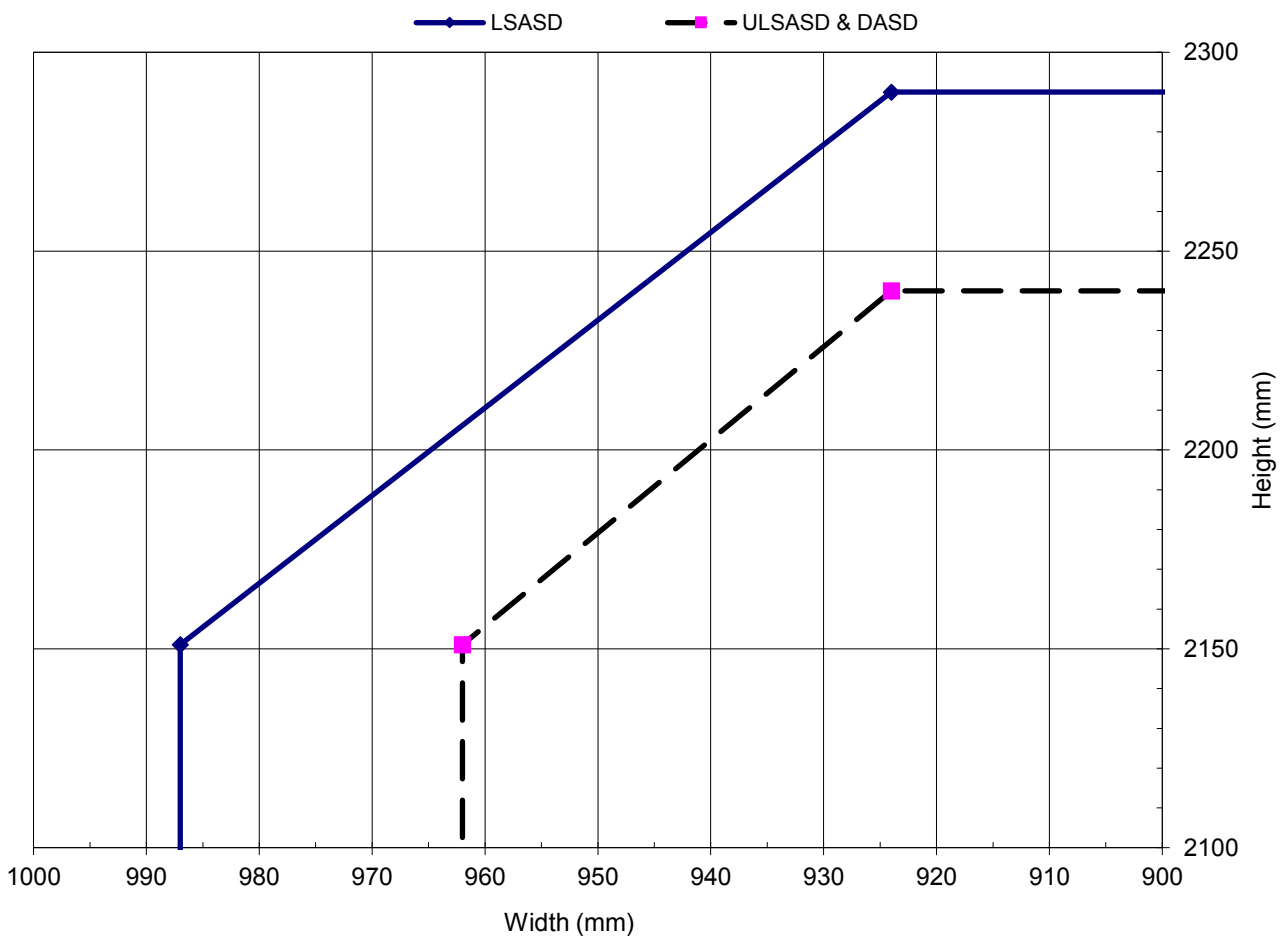

Blankfort 60 (Chipboard Faces) & Blankfort 60+ – Extended Height
Latched & Unlatched, Single & Double Acting, Single Doorsets

	Configuration		Height (mm)	Width (mm)
Leaf Sizes	LSASD	From:	2443	x 971
		To:	2554	x 923
	ULSASD & DASD	From:	2443	x 946
		To:	2504	x 923
Max. Overpanel Height (mm)	Transomed	2000		
Glazing	Max. Glazed Area	0.72m ² (For 1.1m ² see section 6 for details)		
	Approved Systems	See section 6 and appendix B		
Frame Specification	Min. Section (mm)	70 x 32	70 x 30	
	Material	Hardwood	MDF	
	Min. Density (kg/m ³)	640	720	
INTUMESCENT MATERIALS: Pyroplex				
HEAD: 2No. 20 x 4mm strips centrally fitted 4mm either side of the centreline in the leaf edge or frame reveal.				
JAMBS & OVERPANEL: 2No. 20 x 4mm strips centrally fitted 4mm either side of the centreline in the leaf edge or frame reveal.				
HARDWARE PROTECTION: See section 11.				

Maximum Door Leaf Size

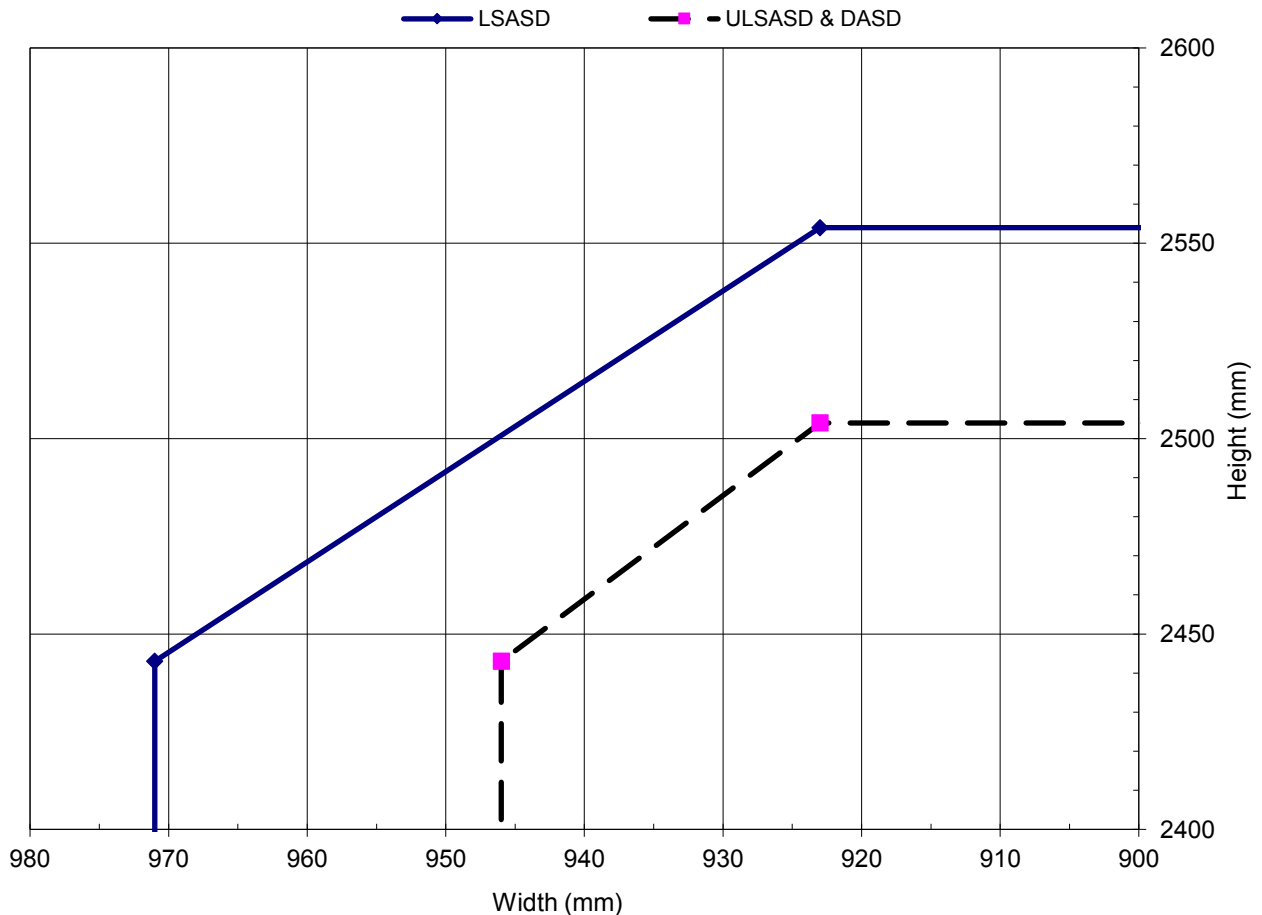

Blankfort 60 & Blankfort 60+ – Pyroplex
Latched & Unlatched, Single & Double Acting, Single Doorsets

Leaf Sizes	Configuration		Height (mm)		Width (mm)	
			From:	To:		
Leaf Sizes	LSASD	From:	2135	x	1002	
		To:	2374	x	890	
Leaf Sizes	ULSASD & DASD	From:	2135	x	977	
		To:	2324	x	890	
Max. Overpanel Height (mm)		Transomed	2000			
Glazing		Max. Glazed Area	0.72m ² (For 1.1m ² see section 6 for details)			
		Approved Systems	See section 6 and appendix B			
Frame Specification		Min. Section (mm)	70 x 32		70 x 30	
		Material	Hardwood		MDF	
		Min. Density (kg/m ³)	640		720	

INTUMESCENT MATERIALS: Pyroplex

HEAD: 2No. 15 x 4mm strips centrally fitted 5mm either side of the centreline in the leaf edge or frame reveal.

JAMBS & OVERPANEL: 2No. 15 x 4mm strips centrally fitted 5mm either side of the centreline in the leaf edge or frame reveal.

HARDWARE PROTECTION: See section 11.

Maximum Door Leaf Size

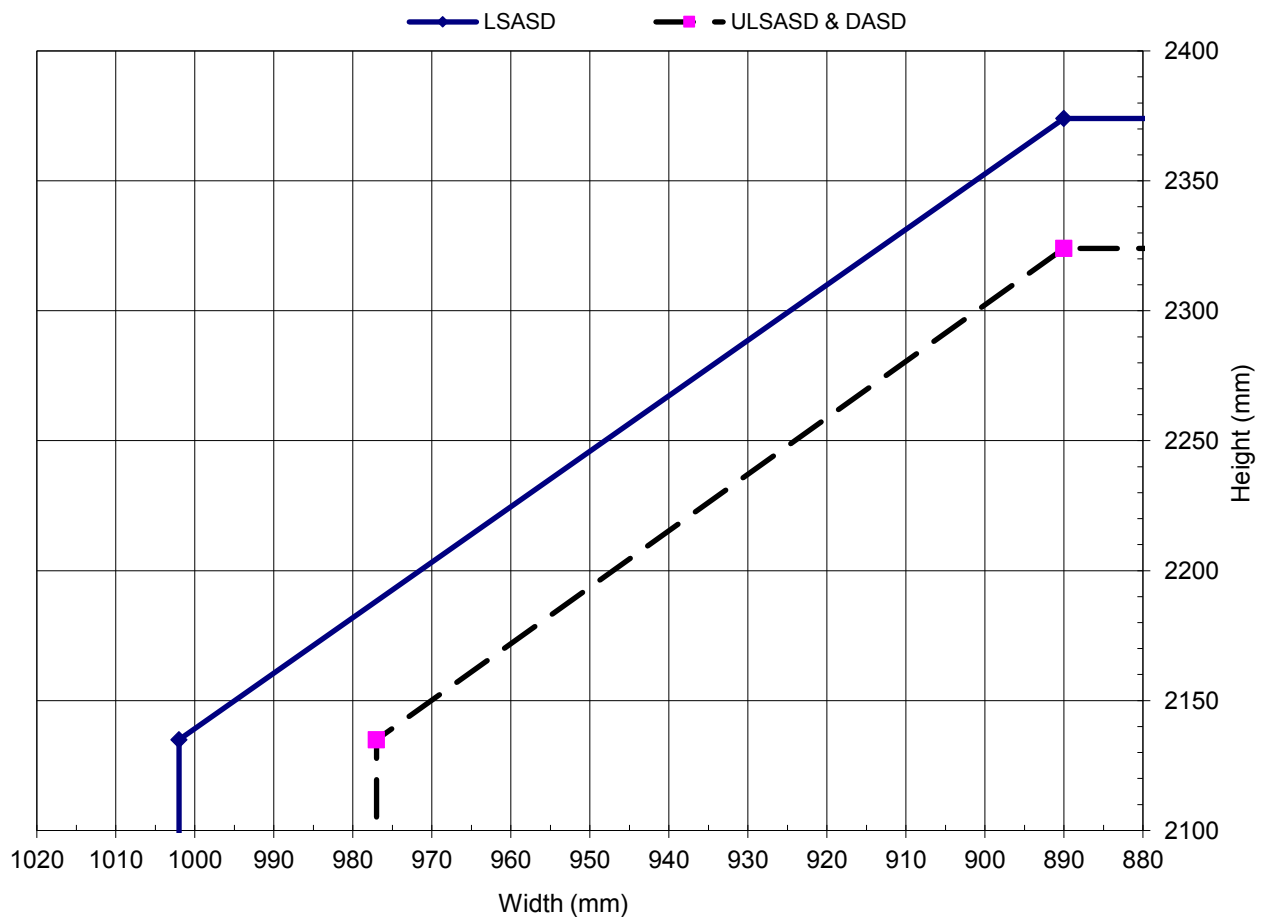

Blankfort 60 & Blankfort 60+ – Pyroplex
Latched & Unlatched, Single & Double Acting, Double Doorsets

	Configuration		Height (mm)		Width (mm)
Leaf Sizes	LSADD	From:	2135	x	952
		To:	2274	x	890
	ULSADD & DADD	From:	2135	x	927
		To:	2224	x	890
Max. Overpanel Height (mm)		Transomed	1500		
Glazing		Max. Glazed Area	0.72m ² (For 1.1m ² see section 6 for details)		
		Approved Systems	See section 6 and appendix B		
Frame Specification		Min. Section (mm)	70 x 32		70 x 30
		Material	Hardwood		MDF
		Min. Density (kg/m ³)	640		720

INTUMESCENT MATERIALS: Pyroplex

HEAD: 2No. 15 x 4mm strips centrally fitted 5mm either side of the centreline in the leaf edge or frame reveal.

MEETING EDGES:

Square: 2No. 15 x 4mm strips centrally fitted 5mm either side of the centreline in one meeting edge only.

JAMBS & OVERPANEL: 2No. 15 x 4mm strips centrally fitted 5mm either side of the centreline in the leaf edge or frame reveal.

HARDWARE PROTECTION: See section 11.

Maximum Door Leaf Size

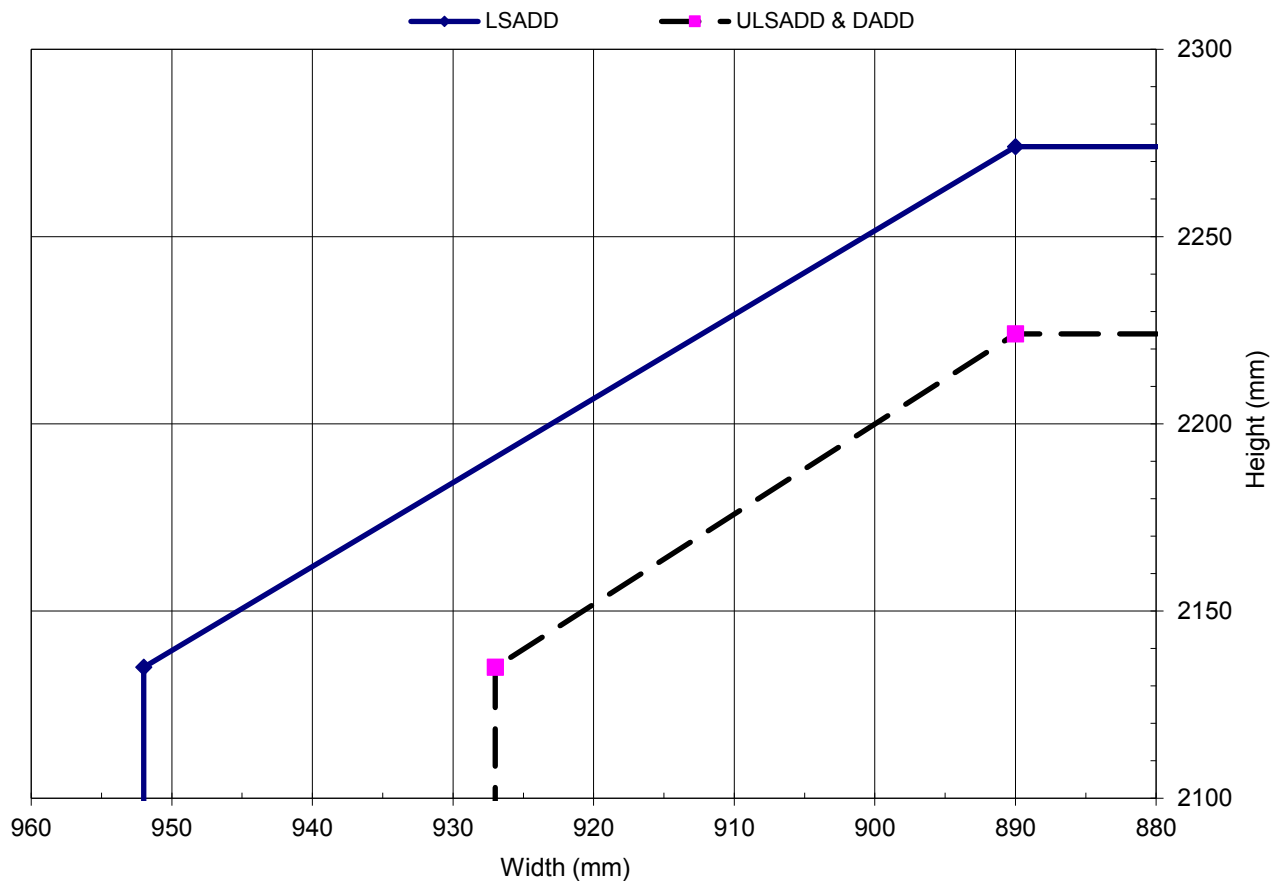

Blankfort 60 & Blankfort 60+ – CS Edge Protectors/Acrovyn Wrap
Latched & Unlatched, Single & Double Acting, Single Doorsets

	Configuration		Height (mm)		Width (mm)
Leaf Sizes	LSASD	From:	2100	x	1034
		To:	2388	x	900
	ULSASD & DASD	From:	2100	x	1009
		To:	2338	x	900
Max. Overpanel Height (mm)	Transomed	2000			
Glazing	Max. Glazed Area	0.72m ² (For 1.1m ² see section 6 for details)			
	Approved Systems	See section 6 and appendix B			
Frame Specification	Min. Section (mm)	70 x 32		70 x 30	
	Material	Hardwood		MDF	
	Min. Density (kg/m ³)	640		720	

INTUMESCENT MATERIALS: Type 617

HEAD:

Square: 2No. 15 x 4mm strips centrally fitted 5mm either side of the centreline in the leaf edge or frame reveal.

JAMBS & OVERPANEL: 2No. 15 x 4mm strips centrally fitted 5mm either side of the centreline in the frame reveal.

HARDWARE PROTECTION: See section 11.

Maximum Door Leaf Size

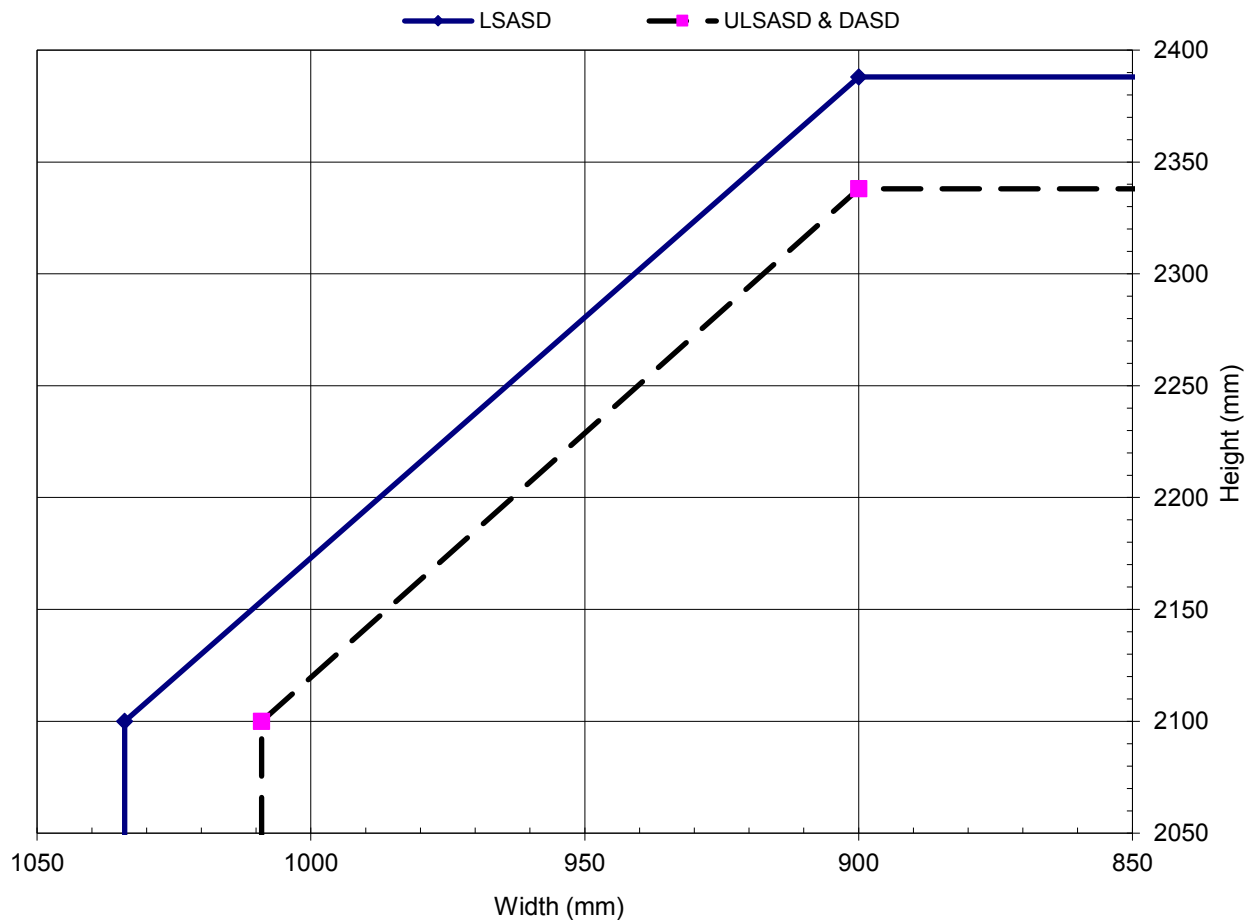

Blankfort 60 & Blankfort 60+ – CS Edge Protectors/Acrovyn Wrap
Latched & Unlatched, Single & Double Acting, Double Doorsets

Leaf Sizes	Configuration		Height (mm)		Width (mm)	
			From:	To:	x	x
	LSADD	From:	2100	x	984	
		To:	2288	x	900	
	ULSADD & DADD	From:	2100	x	959	
		To:	2238	x	900	
Max. Overpanel Height (mm)		Transomed	1500			
Glazing		Max. Glazed Area	0.72m ² (For 1.1m ² see section 6 for details)			
		Approved Systems	See section 6 and appendix B			
Frame Specification		Min. Section (mm)	70 x 32		70 x 30	
		Material	Hardwood		MDF	
		Min. Density (kg/m ³)	640		720	

INTUMESCENT MATERIALS: Type 617

HEAD:

Square: 2No. 15 x 4mm strips centrally fitted 5mm either side of the centreline in the frame reveal.

MEETING EDGES:

Square: 1No. 15 x 4mm strip centrally fitted in the meeting edge of both leaves.

JAMBS & OVERPANEL: 2No. 15 x 4mm strips centrally fitted 5mm either side of the centreline in the frame reveal.

HARDWARE PROTECTION: See section 11.

Maximum Door Leaf Size

