

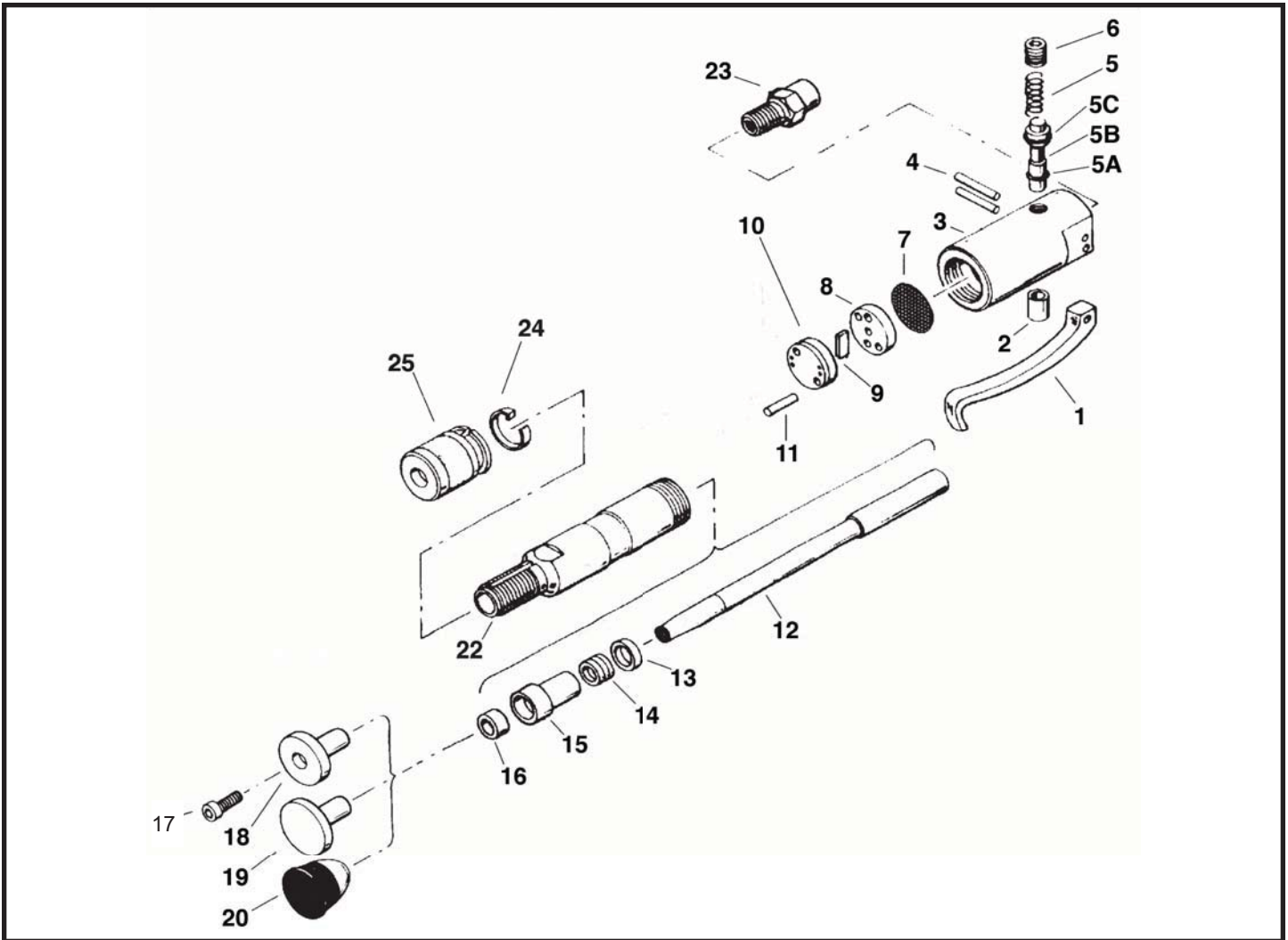

SF-2BAR Rammer



Index	Part No.	Description	List Price
1	S5512-H	Lever	42.27
2	S5510	Throttle Bushing	9.07
3	S5501	Backhead	95.58
4	S5513	Lever Pin (2)	1.86
5	S5503	Throttle Spring	1.75
5A	SC-100	Stem O-Ring	.49
5B	S5511	Throttle Valve	17.86
5C		O-Ring	
6	S5502	Throttle Plug	6.82
7	S5504	Screen	2.24
8	S5505	Valve Lid	22.06
9	S5507	Valve	7.86
10	S5506	Valve Block	78.08

Index	Part No.	Description	List Price
11	S5508	Valve Dowel (2)	2.57
12	S5521	Piston (2-1/2")	132.35
13	S5517	Gland Washer	11.69
14	S5518	Packing Set	19.22
15	S5519A	Packing Gland(2-1/2")	19.22
16	S5524	Wiper Seal	11.85
17	S5530	Butt Screw	1.97
18	SR-5531	Steel Butt (2-1/2")	57.34
19	SR-251S	Rubber Butt (2-3/8")	35.00
22	S5515	Cylinder (2-1/2")	325.47
23	S5514	Screened Inlet	5.14
24	S5516	Lock Clip	11.69
25	S5520	Packing Nut	35.11

****ALL PRICING IS SUBJECT TO CHANGE WITHOUT NOTICE****

Tamco Inc., ♦ 1466 Delberts Drive ♦ Monongahela, PA 15063 ♦ Tel: 1-800-826-2672 ♦ Fax: (724)258-6692

Visit Us Online At <http://www.TamcoTools.com>