



New Brunswick Innova[®] 43/43R Shaker

Operating manual

Copyright © 2015 Eppendorf AG, Germany. No part of this publication may be reproduced without the prior permission of the copyright owner.

Eppendorf® and the Eppendorf logo are registered trademarks of Eppendorf AG, Germany.

BioCommand® is a registered trademark of Eppendorf, Inc., USA.

Innova® is a registered trademark of Eppendorf, Inc., USA.

New Brunswick™ and the New Brunswick™ logo are trademarks of Eppendorf AG, Germany.

Slo-Blo® is a trademark owned and registered by Littlefuse, Inc. Corporation Illinois, USA.

Windows® is a registered trademark of Microsoft Corporation in the United States and other countries.

Trademarks are not marked in all cases with ™ or ® in this manual.

Table of contents

1	Operating instructions	7
1.1	Using this manual	7
1.2	Danger symbols and danger levels	7
1.2.1	Hazard icons	7
1.2.2	Degrees of danger	7
1.3	Symbols used	8
2	Product description	9
2.1	Main illustration	9
2.2	Features	10
2.2.1	Operation	10
2.2.2	Orbit	10
2.2.3	Temperature control	10
2.2.4	Refrigeration (43R only)	10
2.2.5	Safety	11
2.2.6	Alarms	11
2.2.7	Platforms and accessories	11
2.2.8	Software interfaces	12
2.2.9	Lid	12
2.3	Spill pan/water reservoir	12
2.4	Interior light(s)	13
2.5	Heater	13
2.6	Remote alarm (optional)	13
2.7	Service accessibility	13
2.8	Optional components	14
2.8.1	Gas manifold kit	14
2.8.2	Germicidal UV lamp	15
2.8.3	Photosynthetic lamps	15
2.8.4	Humidity monitor	16
3	Safety	19
3.1	User profile	19
3.2	Safety precautions	19
3.3	Application limits	19
3.3.1	Description of ATEX Guideline (94/9EC)	19
3.4	Warnings for intended use	20
4	Installation	23
4.1	Inspection of boxes	23
4.2	Packing list verification	23
4.3	Unpacking equipment	23
4.4	Environment	23
4.4.1	Physical location	24
4.4.2	Electrical requirements	24
4.5	Space requirements	24
4.5.1	Narrow doorways	25
4.6	Leveling the shaker	25
4.7	Installing the platform	26

Table of contents

New Brunswick Innova® 43/43R Shaker
English (EN)

4.8	Install flask clamp	27
4.9	Electrical connections	28
5	Operation	31
5.1	Operating controls	31
5.2	Display operation	32
5.3	Display icons	34
5.4	Screen names and descriptions	34
5.5	Opening the lid	35
5.6	Powering on	35
5.7	Changing screens	36
5.7.1	Choose screens	36
5.8	Display Screen	36
5.8.1	Changing displayed parameters	37
5.8.2	Viewing the setpoints	37
5.8.3	Changing the setpoints	38
5.9	Summary screen	38
5.9.1	Changing setpoint values in the summary screen	39
5.10	Setup screen	39
5.11	Communication/RS-232 screen	40
5.11.1	Changing the communication mode	40
5.11.2	Changing the baud rate	41
5.12	Calibrate screen	41
5.13	Programs screen	42
5.14	Changing the day	42
5.15	Changing the time	43
5.16	Locking the settings	43
5.17	Mute the audible alarm	43
5.18	Temperature offset calibration	44
5.19	Setting temperature offset	44
5.20	Calibrating speed	44
5.21	Program steps	45
5.22	Creating a program	46
5.23	Programming the UV lamp on	47
5.24	Programming the GRO lamp on	48
5.25	Edit a program	48
5.26	Running a program	48
5.27	Program the timer	48
5.28	Filling the spill pan/water reservoir	48
5.29	Draining the spill pan/water reservoir	49
5.30	Mains/Power interruption and fault interruption	49
6	Remote programming	51
6.1	HyperTerminal	51
6.2	Testing the connection	51
6.3	Sending commands	51
6.3.1	Example: Commanding set speed	52
6.3.2	Example: Requesting measured values	52
6.4	Set Commands	53
6.5	Program control commands	53

6.6	Report request commands	55
6.7	Set/get date and time commands	55
6.8	Index to command codes	56
7	Troubleshooting	59
7.1	Troubleshooting	59
8	Maintenance	63
8.1	Routine maintenance	63
8.2	Cleaning external and internal surfaces	63
8.3	Biohazard decontamination	63
9	Technical data	65
9.1	Specifications	65
9.1.1	Shaking	65
9.1.2	Temperature control	65
9.1.3	Power supply	66
9.1.4	Ambient conditions	66
9.1.5	Dimensions and weight	66
9.1.6	Photosynthetic lamps	66
9.1.7	Alarms	67
9.1.8	Display	67
9.1.9	RS-232	67
9.1.10	Setpoint retention	67
9.1.11	Automatic restart	67
9.1.12	ETL regulatory standards	67
9.1.13	CE regulatory standards	67
9.2	Load and speed graphs	67
10	Ordering information	69
10.1	Replacement parts	69
10.2	Accessories	69
10.2.1	Platforms	70
10.2.2	Flask clamps for platforms	71
10.2.3	Test tube racks	72
10.2.4	Optional gas manifold kit	73
10.2.5	Optional photosynthetic grow lamps	73
10.2.6	Optional germicidal lamp	73
10.2.7	Optional humidity monitor	73
10.2.8	Optional utility basket	73
10.2.9	Optional remote alarm	73
11	Transport, storage and disposal	75
11.1	Disposal	75
12	Declaration of conformity	77
	Index	79

Table of contents

New Brunswick Innova® 43/43R Shaker
English (EN)





1 Operating instructions

1.1 Using this manual

- ▶ Carefully read this operating manual before using the device for the first time.
- ▶ Also observe the operating manual enclosed with the accessories.
- ▶ The operating manual should be considered as part of the product and stored in a location that is easily accessible.
- ▶ When passing the device on to third parties, be sure to include this operating manual.
- ▶ If this manual is lost, please request another one. The latest version can be found on our website www.eppendorf.com (international) or www.eppendorfn.com (North America).

1.2 Danger symbols and danger levels

1.2.1 Hazard icons

	Electric shock		Crushing
	Material damage		Hazard point
	Heavy loads		

1.2.2 Degrees of danger

The following danger levels are used in safety messages throughout this manual.

Operating instructions

New Brunswick Innova® 43/43R Shaker
English (EN)

DANGER	<i>Will</i> lead to severe injuries or death.
WARNING	<i>May</i> lead to severe injuries or death.
CAUTION	May lead to light to moderate injuries.
NOTICE	May lead to material damage.

1.3 Symbols used

Example	Meaning
▶	You are requested to perform an action.
1. 2.	Perform these actions in the sequence described.
•	List.
	References useful information.

2 Product description

2.1 Main illustration

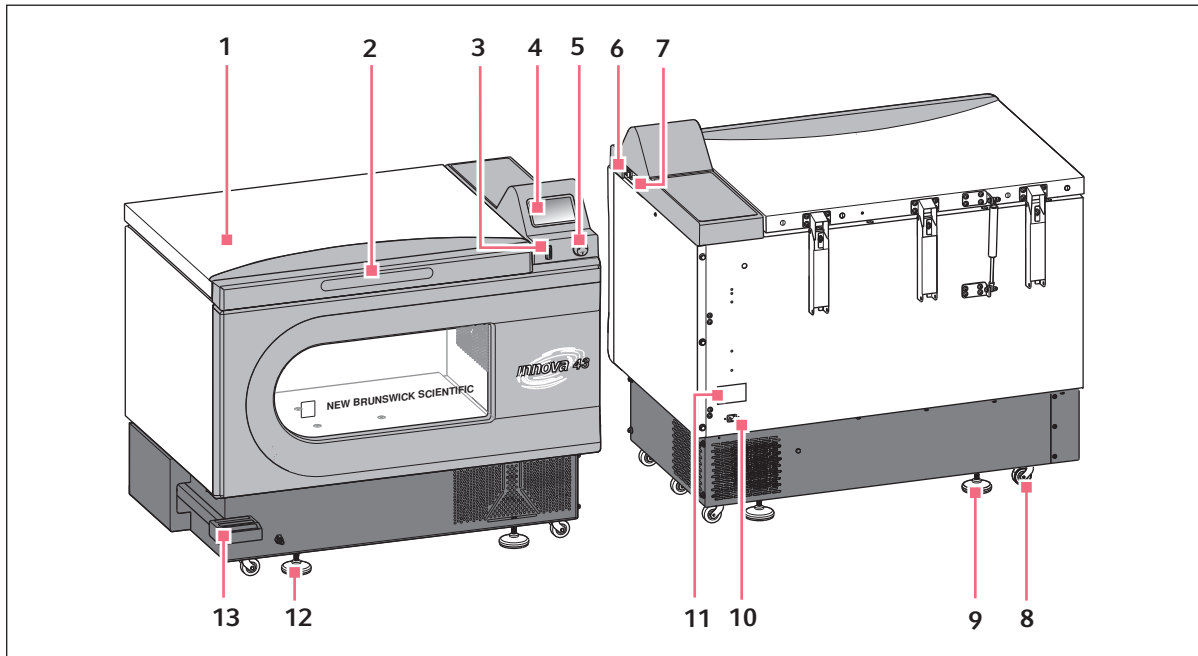

- | | |
|---|--|
| 1 Lid
With automatic stop function | 8 Transport caster
Used to move the device |
| 2 Lid handle | 9 Base stand
Align the device horizontally |
| 3 START/STOP switch
Starts and stops drive | 10 Power connection
Connect the power cable |
| 4 Display
Graphical user interface with display of parameters and parameter values | 11 Name plate
Model number, documentation number, serial number and electrical connection data |
| 5 Push button SELECT control
Change screens or select operating conditions | 12 Quick coupling
Connect the coupler plug to the discharge hose |
| 6 Power switch
Switches device on or off | 13 Foot pedal
Opens the lid |
| 7 RS-232 interface
Read out parameter values and control operational functions using computer applications, also used to connect to BioCommand® SFI | |

Product description

New Brunswick Innova® 43/43R Shaker
English (EN)

2.2 Features

A Proportional/Integral (PI) microprocessor controller with instantaneous digital feedback controls the speed and temperature of the Innova® 43/43R shaker over the entire range.

2.2.1 Operation

The 43/43R Shaker may be operated in a variety of ways.

Continuously	<ul style="list-style-type: none"> At a set speed and temperature, until user stops device
Timed mode	<ul style="list-style-type: none"> At a set speed, time and temperature for a period of up to 99.9 hrs, after which the 43/43R Shaker automatically shuts off
Via programmable controller	<ul style="list-style-type: none"> Through multiple temperature and speed changes for an extended period of time
Via computer	<ul style="list-style-type: none"> Through an RS-232 interface

Please see the Operating section of this manual for more information on the various modes of operation.

2.2.2 Orbit

- Triple eccentric counterbalanced drive mechanism
- Horizontal plane rotary motion
- Available in 2.54 cm (1 in) or 5 cm (2 in) diameter circular orbit

2.2.3 Temperature control

Ambient temperature is measured at 1 m from the exterior of the unit.

- The Innova 43 provides temperature control from 5 °C above ambient to 80 °C
- The Innova 43R provides temperature control from 20 °C below ambient (as low as 4 °C) to 80 °C

Both ranges depend upon relative humidity and other ambient factors, as well as the options installed in the unit (see *Optional components on p. 14*).

2.2.4 Refrigeration (43R only)

The refrigeration system in the Innova 43R is a variable-capacity system carefully designed with self-checks. These self-checks ensure:

- Temperature setpoints are maintained
- Pressure is balanced within the system
- The evaporator surface does not freeze

When the shaker is powered up, there is a 4 min time delay prior to compressor start-up.

2.2.5 Safety

For safe operation, 43/43R Shaker is designed with a safety switch that automatically stops the drive when the lid is opened.

2.2.6 Alarms

The 43/43R Shaker is equipped with visual and/or audible alarms that alert the user to the following conditions:

- The end of a timed run
- Deviations from speed setpoint
- Deviations from temperature setpoint
- Power failure
- Lid open

If an alarm condition exists, the field in the lower right corner of the display will alternate the day and time with characters indicating the nature of the alarm condition, accompanied by an audible alarm (unless muted) (see Tab. on p. 11).

Tab. 2-1: Alarm descriptions

Indication	Description
TEMP	<ul style="list-style-type: none"> • Indicates that the temperature has deviated more than ± 1 °C from setpoint after achieving control temperature range. • After lid is opened, alarm will be disabled for 5 min while chamber recovers to setpoint.
RPM	<ul style="list-style-type: none"> • Indicates that the speed has deviated more than ± 5 rpm from setpoint after achieving operating speed setpoint. • After lid is opened, alarm will be disabled for 5 min while chamber recovers to setpoint.
POWER	<ul style="list-style-type: none"> • Indicates that the unit is powering up (both at normal power-up and after power interruption); will flash until the control knob is moved.
HRS	<ul style="list-style-type: none"> • Indicates when timed run is completed.

2.2.7 Platforms and accessories

To accommodate customer needs, a wide variety of platforms and accessories can be used with the 43/43R Shaker.

Universal platforms	<ul style="list-style-type: none"> • The most flexible • Provides hole patterns for flask clamps, test tube racks and other accessories
Dedicated platforms	<ul style="list-style-type: none"> • Supplied with 1 size of flask clamps attached • Designed solely and expressly for this purpose

Product description

New Brunswick Innova® 43/43R Shaker
English (EN)

The following accessories are also available. For more information about these accessories, (see *Accessories on p. 69*).

- Test tube racks
- Microplate holders
- Erlenmeyer flask clamps (up to 6 L)

**WARNING!**

- ▶ Do not use this equipment with accessories not provided or recommended by Eppendorf, or used in a manner not specified by Eppendorf and this manual. Protection provided by the equipment may be impaired, and serious injury or death can occur.
-

2.2.8 Software interfaces

The RS-232 port is located next to the power switch on the right side of the control panel (see *Remote programming on p. 51*). Using programs like HyperTerminal (see *HyperTerminal on p. 51*), it can be used to connect a computer to the shaker for:

- Control of operating conditions
- Data logging applications



BioCommand SFI software can be used for data logging through the use of the RS-232 port.

The customer is responsible for securing the proper driver to interface with the RS-232.

2.2.9 Lid

The chamber of the Innova 43/43R Shaker is accessed through the top-opening hinged lid. To open the lid, firmly press the pedal or lift up on the front handle. The lid stays on its hinges until you choose to close it.

When the lid is open:

- The heater turns off
- The shaker stops
- The interior light goes on and will remain on for 15 s after the lid is closed (when the shaker is in AUTO mode)
- UV germicidal lamp (if so equipped) turns off

2.3 Spill pan/water reservoir

The 43/43R Shaker is equipped with a spill pan/water reservoir and cover to protect the drive mechanism in the case of accidental spills and/or broken glassware.

If the optional factory-installed humidity monitor is present, the pan can be used as a water reservoir to humidify the chamber and reduce evaporation.

The pan/reservoir can also be used to increase humidity in the chamber without the humidity monitor, but the results will not be monitored.

The pan/reservoir can be drained through the quick-connect valve at the front of the unit.

2.4 Interior light(s)

When the *LAMP* screen is in its default *AUTO* mode, the interior (chamber) light is activated for 15 s when you turn the control knob. It will automatically shut off after 15 s of control knob inactivity. The chamber light will also go on when the lid is opened.

The chamber light can also be programmed as continuously on or continuously off by selecting either mode in the *LAMP* screen.

2 additional light options exist for refrigerated units only:

- Interior photosynthetic grow lamps
- Germicidal UV lamp, located outside the chamber but in the airflow path

2.5 Heater

The chamber temperature is sensed by a 1000 ohm platinum RTD. A 650 W heater is controlled using pulse width modulation on a 2.5 s duty cycle. This cycle time is fast enough to prevent noticeable changes in air temperature due to the cycling.

2.6 Remote alarm (optional)

The Innova 43/43R Shaker can be equipped with a factory-installed remote alarm component (part number M1320-8029). When it is hooked up to your relay and receiving equipment, this device will send notification of an alarm condition to the remote location you choose.

2.7 Service accessibility

In the unlikely event that your Innova 43/43R Shaker should need service, all electronic boards, refrigeration and heating components are mounted on a pull-out drawer mechanism which is easily accessed **by an authorized service technician**.

Product description

New Brunswick Innova® 43/43R Shaker
English (EN)

2.8 Optional components**2.8.1 Gas manifold kit**

This option is factory installed (see *Optional gas manifold kit on p. 73*).

The manifold delivers gas into the chamber via as many as 12 ports. The manifold can be adapted to the desired tubing configuration by adding or subtracting ports or by temporarily clamping off unused tubes. You may elect to use splitters (barbed Y-connectors) after the manifold to increase the number of flasks you can serve.

You determine the appropriate gas flow rate using a pressure regulator (which you supply) on the gas supply.



Gas supply should be regulated. It must never exceed 15 PSIG.

50 ft of 1/16 in (ID) sterilizable silicone tubing is supplied with the kit. If filters are needed, 0.22 µm user-supplied syringe filters can be fitted to the individual manifold ports to maintain a sterile barrier.

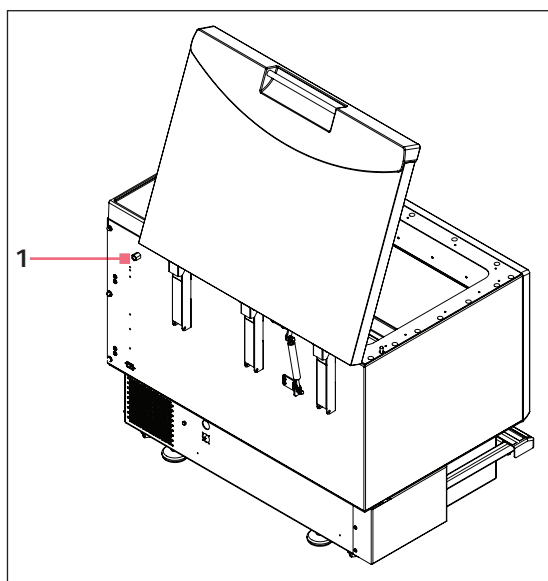
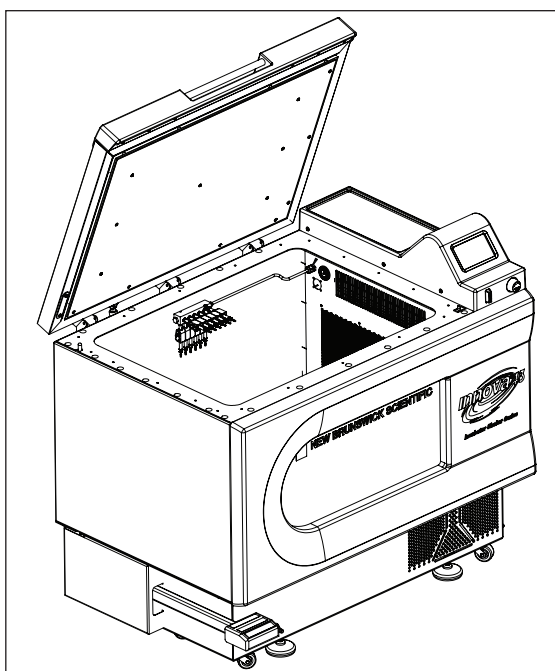

1 Gas manifold connection (1/4 FNPT)

**CAUTION!**

- ▶ Never use the gas manifold with flammable gases.
- ▶ Never exceed 15 PSIG inlet pressure to the manifold.
- ▶ Make sure free lengths of tubing are secured by the hook and loop straps to keep them from contact with flasks or other moving parts.

2.8.2 Germicidal UV lamp



CAUTION!

- ▶ Never try to operate the UV Germicidal Lamp while the shaker lid is open.

This option is factory installed and available for refrigerated units only. Operation instructions are provided with this option (see *Optional germicidal lamp on p. 73*).

The germicidal ultraviolet lamp is placed inside the Service Compartment but outside the chamber, to reduce the risk of contamination.

On the screen, the lamp is identified as UV.

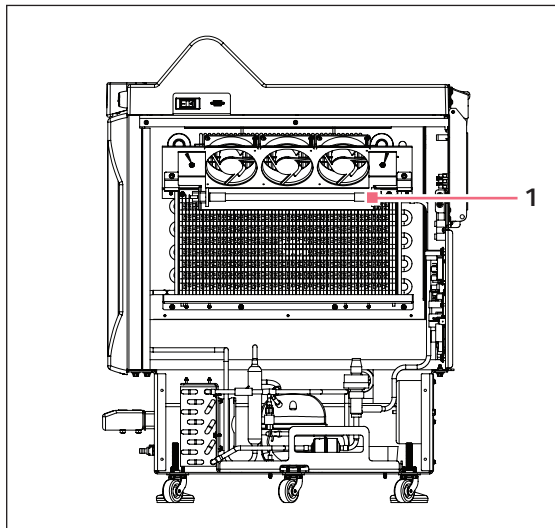

Fig. 2-1: UV lamps (side of shaker)

1 UV lamps

2.8.3 Photosynthetic lamps

This option is factory installed and available for refrigerated units only (see *Optional photosynthetic grow lamps on p. 73*).

If selected, this option provides 9 photosynthetic growth lamps inside the chamber. The lamps can be turned on and off manually, via the easily set programmable timer or computer.

Product description

New Brunswick Innova® 43/43R Shaker
English (EN)

The lamps are identified on the display screen as *GRO*.

Recommended operating temperature	15 °C – 37 °C
Maximum operating temperature	70 °C

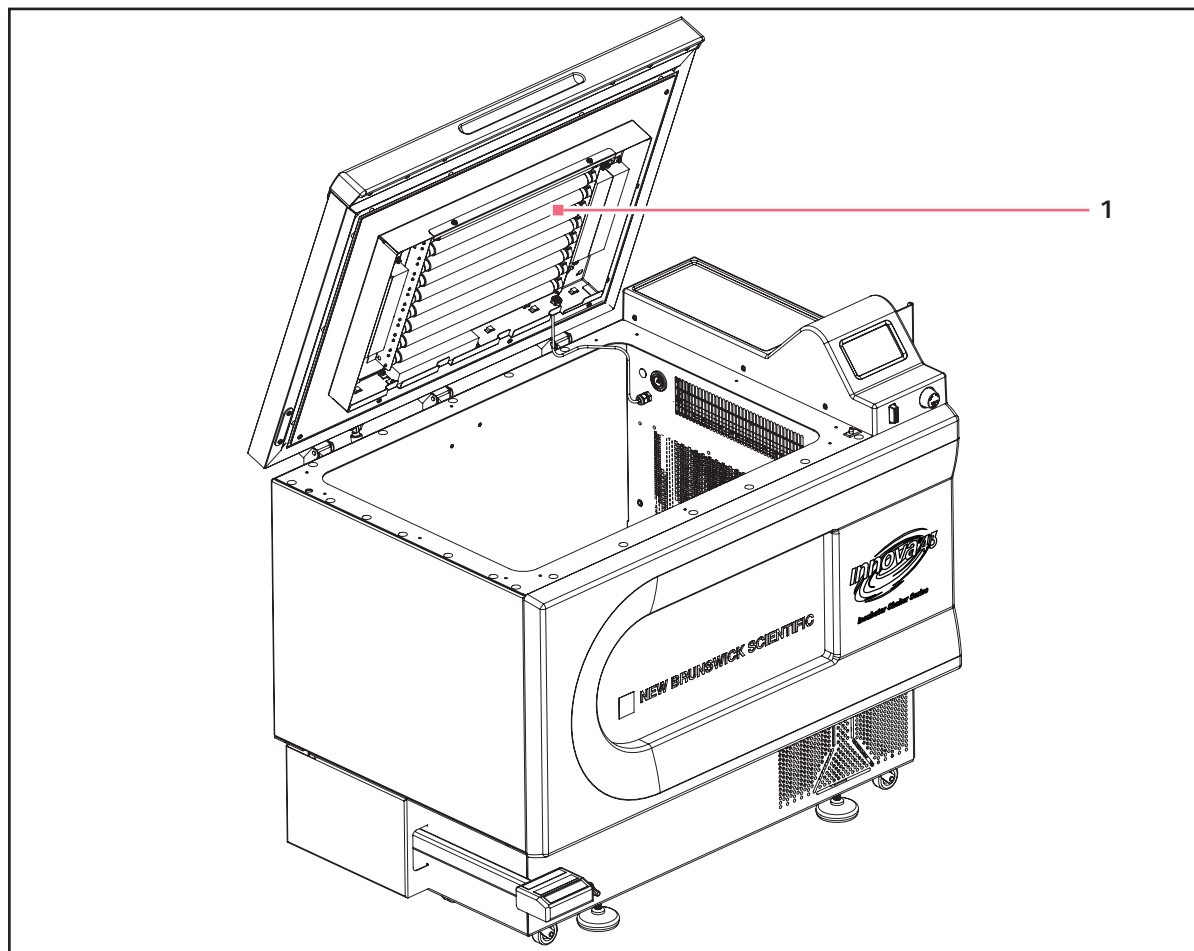
**1 Photosynthetic lamp assembly****2.8.4 Humidity monitor**

This option is factory installed (see *Optional humidity monitor on p. 73*).

The humidity monitor allows you to monitor relative humidity levels in the chamber throughout your run.

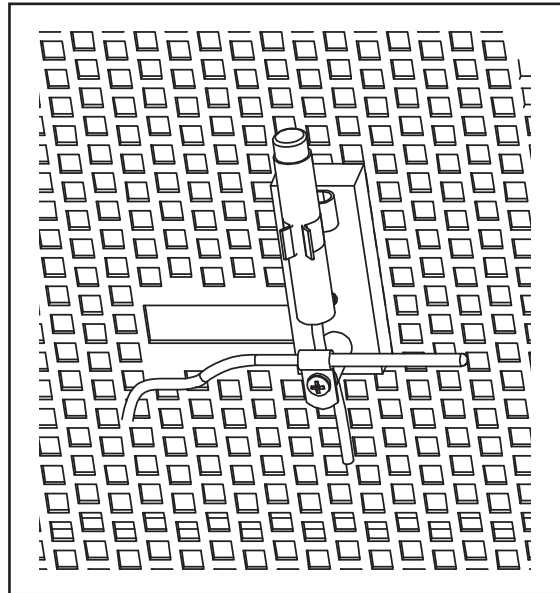
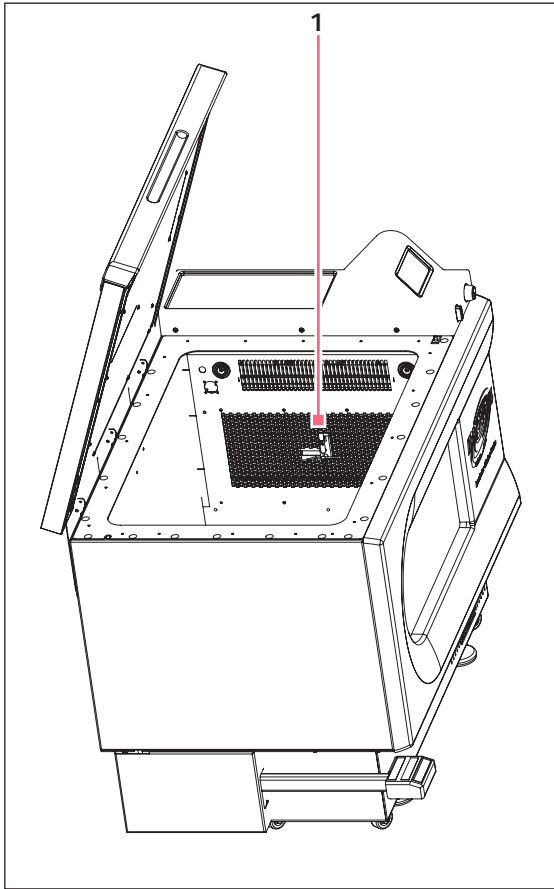

Fig. 2-2: Humidity sensor mounting (inside wall of cabinet)

1 Humidity monitor



When the humidity sensor is present in the chamber, maximum shaker temperature is **automatically** limited to 60 °C.

Humidity operating range	0 % – 100 % TH
Temperature operating range	4 °C – 60 °C
Accuracy	(see Fig. 2-2 on p. 18)
Hysteresis	±1.5 % RH
Recovery time after saturation	10 seconds
Long term stability	0.5 % RH per year

Product description

New Brunswick Innova® 43/43R Shaker
English (EN)

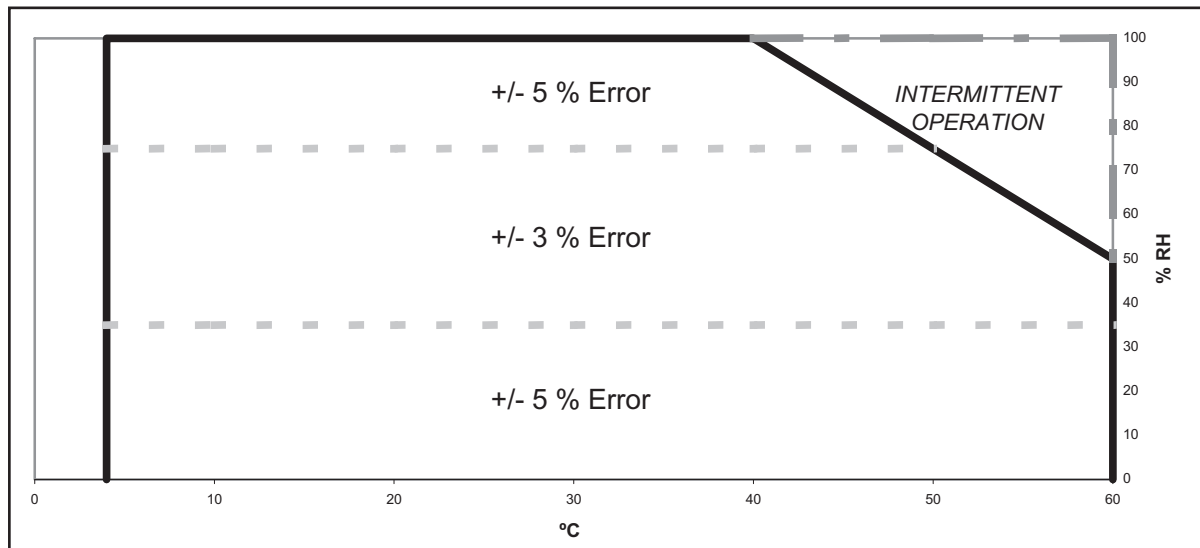
**CAUTION!**

- ▶ Operating the 43/43R Shaker at temperatures above 60 °C can result in permanent damage to the sensor.

Water can be added to the spill pan/water reservoir in order to elevate the humidity on the chamber (see *Spill pan/water reservoir on p. 12*)(see *Filling the spill pan/water reservoir on p. 48*).

3 Safety

3.1 User profile

The device may only be operated by trained lab personnel who have carefully read the operating manual and are familiar with the device functions.

3.2 Safety precautions

Before operating the shaker, verify that anyone involved with its operation has been instructed in both general safety practices for laboratories and specific safety practices for this apparatus.

- The user is also responsible for following local guidelines for handling hazardous waste and biohazardous materials that may be generated from the use of this equipment.

It is the responsibility of the user to carry out appropriate decontamination procedures if hazardous material is spilled on or inside the equipment. Before using any cleaning or decontamination method other than those suggested by the manufacturer, users should check with Eppendorf that that proposed method would not damage the equipment.



This equipment is not *explosion-proof*, and should never be used with flammable substances or used to grow organisms that produce flammable by-products.



WARNING! Risk of explosion and injury or death!

- ▶ Do not use equipment with flammable substances or organisms with flammable by-products.



NOTICE! Damage to device!

- ▶ Never run shaker without a platform.

3.3 Application limits

3.3.1 Description of ATEX Guideline (94/9EC)



DANGER! Explosion hazard

- ▶ Do not operate the device in areas where work is completed with explosive substances.
- ▶ Do not use this device to process any explosive or highly reactive substances.
- ▶ Do not use this device to process any substances which could create an explosive atmosphere.

Safety

New Brunswick Innova® 43/43R Shaker
English (EN)

**CAUTION! Lack of safety due to incorrect use of materials**

- ▶ Do not use this device to process any flammable materials, or use materials where the transfer of mechanical energy to glass apparatus could lead to breakage.

Due to its design and the ambient conditions in its interior, the device is not suitable for use in potentially explosive atmospheres.

The device may only be used in a safe environment, e.g., the open atmosphere of a ventilated lab.

3.4 Warnings for intended use

**WARNING! Heavy!**

- ▶ Do not attempt to lift the Innova 43/43R Shaker by yourself.
- ▶ Ask for assistance or use suitable equipment when raising or handling the device.

**WARNING! Risk of electric shock and/or damage to unit!**

- ▶ Check that the voltage and frequency of your unit are compatible with mains/power supply.
- ▶ Remove caution label from back of unit.
- ▶ Set the circuit breaker on the right side of the unit to the OFF position.

**WARNING! Risk of electric shock and/or damage to device!**

- ▶ Use a grounded power supply.

**WARNING! Risk of electric shock and/or damage to the device!**

- ▶ Before cleaning device, turn off and unplug from mains/power supply.

**WARNING! Risk of electric shock when replacing fuses!**

- ▶ Turn off shaker and disconnect from mains/power supply.

**WARNING! Injury from hazardous biological material!**

- ▶ Use respiratory protection when cleaning spills where aerosolization is suspected.
- ▶ Wear gloves, safety glasses, and laboratory coat when cleaning.



NOTICE! Damage to device!

- ▶ Never run shaker without a platform.
-

Safety

New Brunswick Innova® 43/43R Shaker
English (EN)

4 Installation

4.1 Inspection of boxes

After you receive your order from Eppendorf, inspect the boxes carefully for any damage that may have occurred during shipping. Report any damage immediately to the carrier and your local Eppendorf customer service department.

4.2 Packing list verification

Verify against your Eppendorf packing list that you have received all of the correct materials.

4.3 Unpacking equipment



WARNING! Heavy!

- ▶ Do not attempt to lift the Innova 43/43R Shaker by yourself.
 - ▶ Ask for assistance or use suitable equipment when raising or handling the device.
-

To unpack your 43/43R Shaker, you will need the following:

- Claw hammer
 - Scissors (to cut nylon strapping)
 - Tool to remove 7.6 cm (3 in) metal staples
-



CAUTION! Lack of safety due to humid storage and transport conditions

- ▶ Unit needs to be evaluated for condensation when received and unpacked for installation.
 - ▶ If condensation due to storage and transport in humid conditions has occurred, please allow for a 4 hour drying-out time in an environment of 18 °C – 25 °C, and 30 % – 80 % relative humidity. Without this drying-out process, the unit cannot be assumed to meet safety requirements.
-

4.4 Environment

The shaker is designed to operate optimally in the following ambient conditions:

- 10 °C – 35 °C
- Up to 2000 m altitude limit
- 20 % – 80 % relative humidity

Installation

New Brunswick Innova® 43/43R Shaker
English (EN)

4.4.1 Physical location

It is essential that the instrument be situated in an area where there is sufficient space for the shaker to clear walls and potential obstructions during operation. The surface on which the unit is placed must be smooth, level, and able to support the shaker under full load operating conditions.



WARNING! Heavy!

- ▶ Do not attempt to lift the Innova 43/43R Shaker by yourself.
- ▶ Ask for assistance or use suitable equipment when raising or handling the device.



The 43/43R Shaker has casters and leveling feet. When you need to move the unit across the floor, make sure the feet are raised enough so that the casters can move freely without scraping the floor with the feet.

At all other times, ensure that the feet are down to avoid any unintended rolling.

4.4.2 Electrical requirements

Power supply	100 V \pm 10 %, 50 – 60 Hz 120 V \pm 10 %, 60 Hz 230 V \pm 10 %, 50 Hz	800 VA 1500 VA
--------------	--	-------------------

Check your shaker's electrical specification plate (located on the back of the unit) to be sure the electrical requirements of your unit match the output of your electric supply. If they do not match, contact your Eppendorf customer service representative.

4.5 Space requirements

Allow at least 10 cm (4 in) around the shaker for proper ventilation, access to the power switch and access to the RS-232 port.

Also allow enough room above the shaker for the lid to be fully open.



Be sure to keep the power plug and power outlet easily accessible to facilitate unplugging the unit as needed.

Dimensions:

Depth	81 cm	32 in
Width	115.6 cm	45.5 in
Height	103 cm	40.6 in
Height (with lid open)	162.7 cm	64.1 in

4.5.1 Narrow doorways

If you need to move the 43/43R Shaker through a doorway that is less than 82.5 cm (32.5 in) wide, you will need to remove the front window cover to reduce the depth of the unit to 77 cm (30.3 in). To do this:

1. Carefully remove the 5 screws on the underside of the plastic window cover.
Retain the screws for reuse.
2. Being very careful not to hit the control knob or button, slide the window cover upward to remove it from the spring clips on the front of the unit.

When the shaker is in the desired location, reinstall the window cover by reversing the procedure.

4.6 Leveling the shaker



WARNING! Heavy!

- ▶ Do not attempt to lift the Innova 43/43R Shaker by yourself.
- ▶ Ask for assistance or use suitable equipment when raising or handling the device.

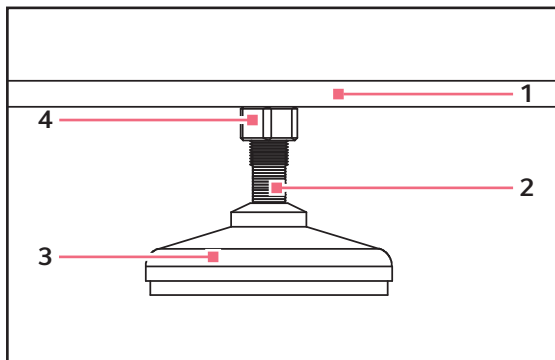

Fig. 4-1: Shaker foot

- | | |
|---------------------------|-------------------|
| 1 Bottom of unit | 3 Foot |
| 2 Flats for wrench | 4 Lock nut |

The 43/43R Shaker has casters and leveling feet. When you need to move the unit across the floor, make sure the feet are raised enough so that the casters can roll freely without scraping the floor with the feet.

- Make sure that the shaker is placed on a level surface, in its intended location.
- Lower all 4 adjustable feet until they are solidly on the surface.

If the shaker is not level, adjust the feet as needed to achieve leveling:

Installation

New Brunswick Innova® 43/43R Shaker
English (EN)

1. Immobilize the top lock nut against the unit with 1 wrench (**whenever you adjust the foot**) to keep the threaded stud from falling out.
2. Using a second wrench placed against the flats of the threaded nut (just above the foot), rotate counterclockwise to lower the foot.
3. Rotate counter-clockwise to raise the foot.
4. Place a level at the top of the unit.
5. If necessary, make further adjustments by repeating all steps until the unit is level.
6. After installing the platform (see *Installing the platform on p. 26*), fully load the shaker and do a test run at normal speed.
7. Make additional leveling adjustments if necessary.

4.7 Installing the platform



NOTICE! Damage to device!

- ▶ Never run shaker without a platform.

The 43/43R Shaker can be used with a variety of Eppendorf platforms that will accept a wide range of clamps for flasks, test tubes, etc. (see *Accessories on p. 69*). A platform, **which is required for operation**, is a separate item, not included with the shaker assembly. The shaker is shipped with 4 Allen head platform screws installed in the bearing housing.

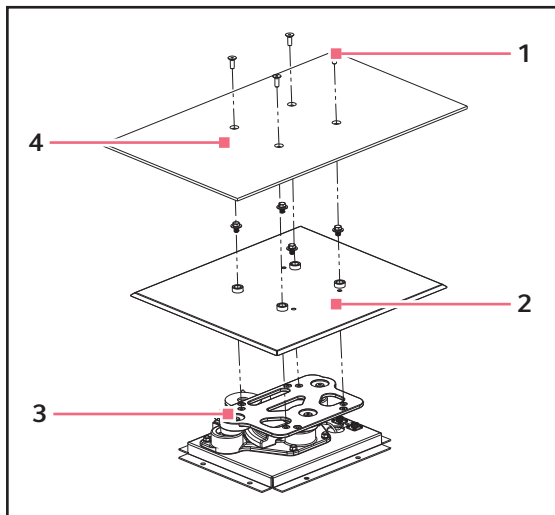

Fig. 4-2: Installing platform and spill cover

- 1 Platform screws
- 2 Spill cover

- 3 Bearing housing
- 4 Platform

To install the platform in your 43/43R Shaker:

1. Make sure the unit is unplugged and the power switch is in the Off position.
2. Open the cover.
3. Remove the 4 Allen head platform screws installed in the bearing housing.
4. Place the platform on the top plate of the bearing housing.
5. Reinstall the 4 Allen head platform screws to secure the platform.

4.8 Install flask clamp



Eppendorf flask clamps are used on a variety of shaker platforms. Flat head screws of different lengths and thread pitch are used to secure the clamp.

To install flask clamps, you will need:

- Phillips screwdriver
- 10 – 24 × 5/16 in (7.9 mm) flat Phillips screws

Flask clamps purchased for use with universal platforms require installation (see Fig. 4-3 on p. 28). Clamps are installed by securing the base of the clamp to the platform with the correct type and number of screws. All clamps are shipped complete with hardware.

Clamps for 2 L, 2.8 L, 4 L and 6 L flasks are shipped with an additional girdle to keep the flasks in place.

Installation

New Brunswick Innova® 43/43R Shaker
English (EN)

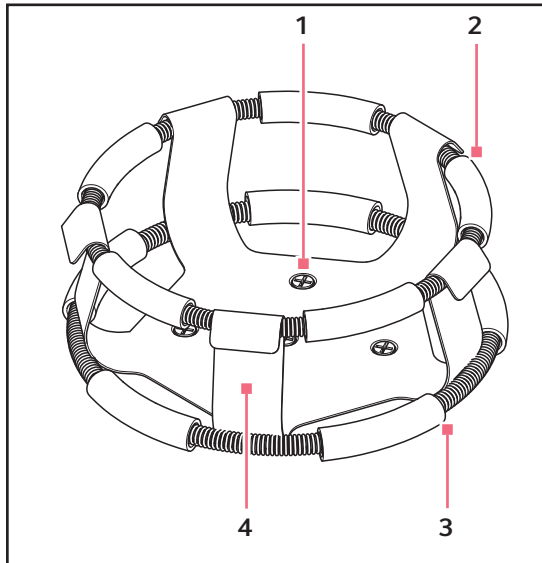

Fig. 4-3: Double girdle clamp

- 1 Clamp mounting holes (with screws)**
- 2 Upper girdle with girdle tubes**
Secures the flask within the clamp
- 3 Lower girdle with girdle tubes**
Prevents the flask from spinning
- 4 Clamp body (legs and base)**

To install these double girdle clamps:

1. Place the clamp on the platform, aligning it with the mounting holes with the holes on the platform.
2. Secure the clamp in place using the provided screws (#S2116-3051, 10-24 × 5/16 in Phillips head).

i Do not overtighten the screws.

3. Place the loose girdle around the upper portion of clamp body so that it is held in place by the legs of the clamp.
4. Insert the flask into the clamp.
5. Push the girdle down so the rubber tubes are in contact with the platform and the flask.

Description	Part No.	Quantity	Application
10 – 24 × 5/16 in (7.9 mm) 	S2116-3051	1	5/16 in (7.9 mm) thick aluminum, phenolic and stainless steel platforms

4.9 Electrical connections

Before making electrical connections, verify that:

- An earthed/grounded electrical outlet is necessary for the safe operation of this equipment.
- The power source voltage matches the voltage on the electrical specification plate.
- The ON/OFF switch is in the OFF position.

i The electrical specification plate is located on the rear panel of the unit near the power connector.

To set up an electrical connection to your 43/43R Shaker:

1. Connect the power cord to the power connector.
2. Connect the other end of the power cord to a suitable, earthed/grounded receptacle.

i Make sure there is enough clearance to disconnect the plug whenever necessary.

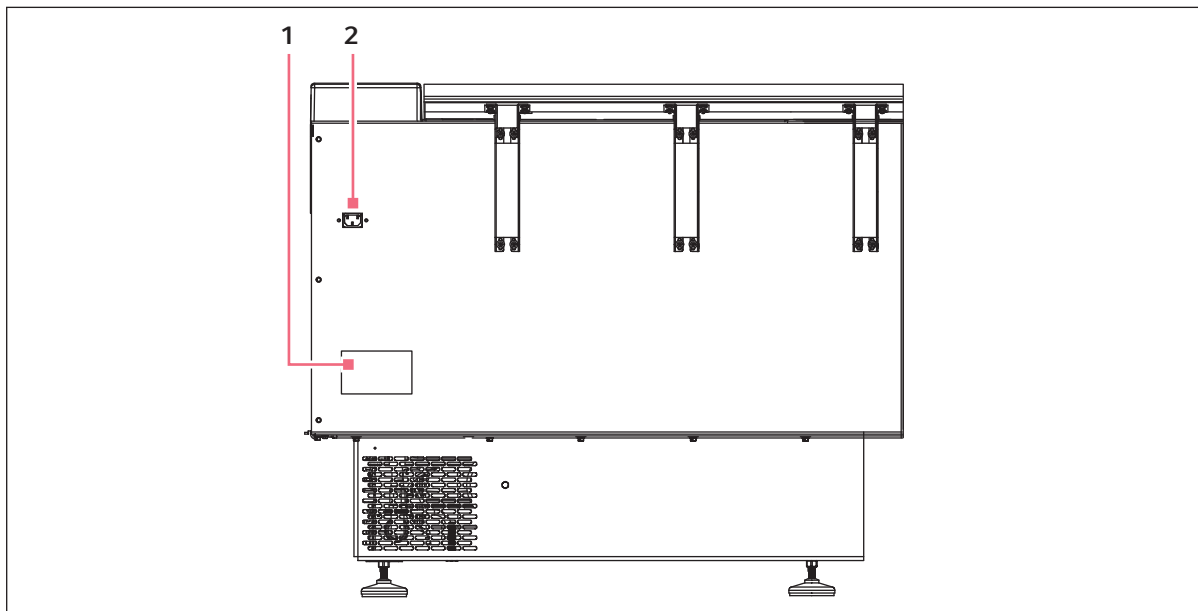

Fig. 4-4: Rear panel

1 Electrical specification plate

2 Power connector

Installation

New Brunswick Innova® 43/43R Shaker
English (EN)

5 Operation
 5.1 Operating controls

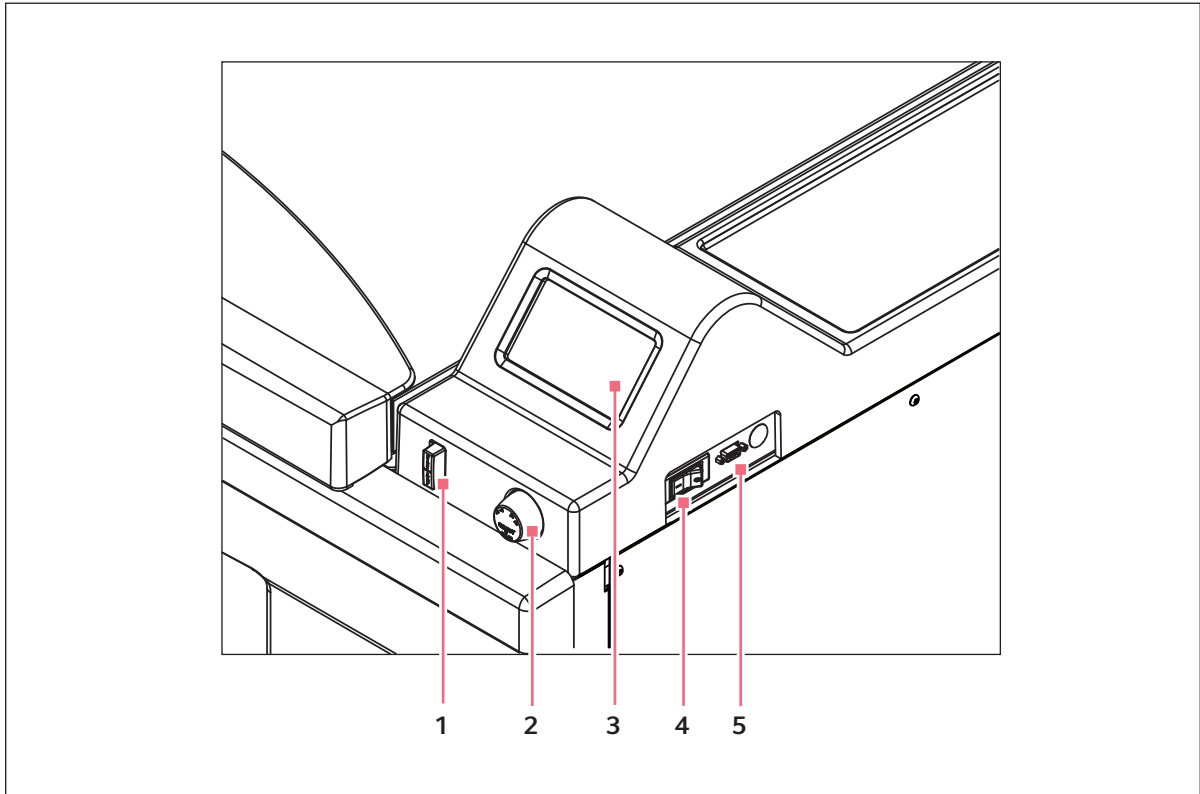

- | | |
|-----------------------------------|----------------|
| 1 START/STOP switch (for shaking) | 4 Power switch |
| 2 Control knob | 5 RS-232 port |
| 3 Display | |

START/STOP switch	<ul style="list-style-type: none"> • Used to start or stop the drive • Activates timer when timed run is desired • If the unit is stopped and restarted, the timer automatically returns to the beginning of a run
Control knob	<ul style="list-style-type: none"> • Used to change screens • Used to select operating conditions • Used to change operating conditions
RS-232 port	<ul style="list-style-type: none"> • Read out parameter values • Controls operational functions using computer applications • Used to connect to BioCommand SFI
Power switch	<ul style="list-style-type: none"> • Circuit breaker • Turns power on and off to the 43/43R Shaker

Operation

New Brunswick Innova® 43/43R Shaker
English (EN)



In addition to the power switch, the power cord is also used to conduct power or break the power circuit to the shaker.

Whenever power to the shaker may be a hazard (during maintenance, cleaning or service work), be sure to disconnect the power cord from the electrical outlet.

5.2 Display operation

When the unit is powered up using the START/STOP switch located on the front panel (see *Operating controls on p. 31*), the initial display screen will remain for a short time while the system boots up.

The main screen, called *DISP* for Display, appears next. This screen will indicate the same parameters that were in effect when the power was turned off.

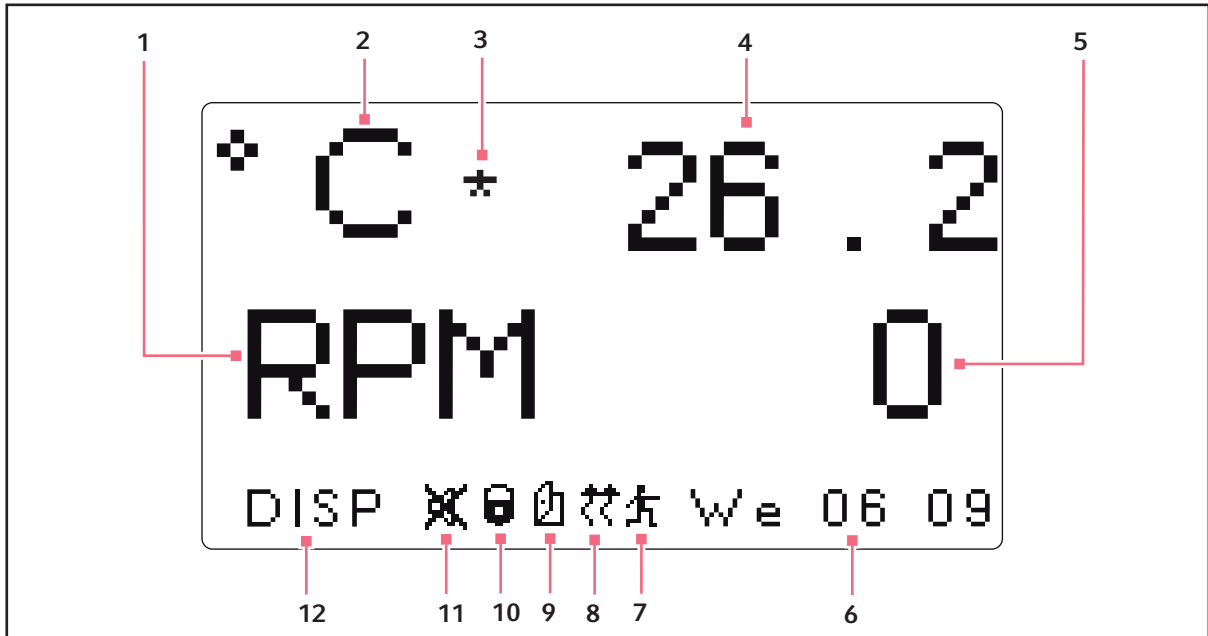

Fig. 5-1: Display screen

- | | |
|---|---|
| <p>1 Speed
Parameter</p> <p>2 Temperature
Parameter</p> <p>3 Temperature offset
Icon appears to the right of °C if the temperature offset feature is being used</p> <p>4 Temperature
Temperature parameter value</p> <p>5 Speed
Speed parameter value</p> <p>6 Day and 24-hour time</p> | <p>7 Program running
Icon appears when user-defined program is running</p> <p>8 Heater on
Icon appears when heater is on</p> <p>9 Lid open
Icon appears when lid is open</p> <p>10 Parameters locked
Icon appears when the possibility to make manual or programmed parameter changes is disabled (locked), controlled by settings in the <i>SET</i> screen</p> <p>11 Audible alarms muted
Icon appears when audible alarms are muted</p> <p>12 Screen name</p> |
|---|---|

Parameter name and meanings:







Parameter name	Meaning
RPM	Shaking speed, in revolutions per minute
°C	Chamber temperature, in degrees Celsius
HRS	Programmed time remaining, in hours

Operation

New Brunswick Innova® 43/43R Shaker
English (EN)

5.3 Display icons

There are 6 icons that help identify operating conditions:

Icon	Explanation	Location
	<ul style="list-style-type: none"> Appears when audible alarms are muted 	<ul style="list-style-type: none"> Bottom of screen Visible in any screen except Program subscreens
	<ul style="list-style-type: none"> Appears when the possibility to make manual or programmed parameter changes has been disabled (locked) Controlled by settings on the <i>SET</i> screen 	<ul style="list-style-type: none"> Bottom of screen Visible in any screen except Program subscreens
	<ul style="list-style-type: none"> Appears when the shaker lid is open 	<ul style="list-style-type: none"> Bottom of screen Visible in any screen except Program subscreens
	<ul style="list-style-type: none"> Appears when the heater is on 	<ul style="list-style-type: none"> Bottom of screen Visible in any screen except Program subscreens
	<ul style="list-style-type: none"> Appears when a user-defined program is running 	<ul style="list-style-type: none"> Bottom of screen Visible in any screen except Program subscreens
	<ul style="list-style-type: none"> Appears to the right of °C if the temperature offset feature is being used 	<ul style="list-style-type: none"> To the right of °C Visible whenever the temperature is on screen

5.4 Screen names and descriptions

There are 7 available screens:

Tab. 5-1: Screen names and descriptions

Screen name	Meaning	Description
<i>DISP</i>	Display	<ul style="list-style-type: none"> Displays 2 user-selectable parameters and measured values Change setpoint values (see <i>Display Screen on p. 36</i>)

Screen name	Meaning	Description	
<i>SUMM</i>	Summary	<ul style="list-style-type: none"> • Displays all parameters, measured values, and setpoints • Change all parameters, measured values, and setpoints (see <i>Summary screen on p. 38</i>) 	
<i>SET</i>	Set	<ul style="list-style-type: none"> • Set day of the week • Set time • Enable alarm • Mute alarm • Lock operating parameters • Unlock operating parameters 	
<i>LAMP</i>	Lamps	Internal chamber light	<ul style="list-style-type: none"> • ON (always on) • OFF (always off) • AUTO (default mode) • Stays on when lid is open • Shuts off 15 seconds after lid is closed • Goes on for 15 seconds when control knob is moved
		<ul style="list-style-type: none"> • UV light • Photosynthetic lights 	<ul style="list-style-type: none"> • ON • OFF • NONE (not installed)
<i>COMM</i>	Communication	<ul style="list-style-type: none"> • Set the communication mode • Set the baud rate • (see <i>Communication/RS-232 screen on p. 40</i>) 	
<i>CAL</i>	Calibration	<ul style="list-style-type: none"> • Enter temperature offset • Calibrate speed (see <i>Calibrate screen on p. 41</i>) 	
<i>PROG</i>	Program	<ul style="list-style-type: none"> • Set up 1 – 4 programs, each with 1 – 15 steps (see <i>Programs screen on p. 42</i>) 	

5.5 Opening the lid

Open the lid by firmly pressing the foot pedal or lifting up on the front handle. The lid will stand open on its hinges until you swing it down to the closed position.

5.6 Powering on

1. Close the lid.
2. Turn the power switch to the On position.
The display will come on (briefly displaying product information, and then moving into the *DISP* screen). An audible alarm will sound.
3. Turn the control knob to turn alarm off.

Operation

New Brunswick Innova® 43/43R Shaker
English (EN)

When the shaker begins to operate, the display will track the speed as it accelerates to the last entered setpoint. The shaking action may be started or stopped by pressing the START/STOP switch on the front panel.



The shaker will not operate if the lid is open. This is indicated by the lid open icon appearing in the bottom line of the display (see *Display icons on p. 34*).

5.7 Changing screens

5.7.1 Choose screens

In this example, we are changing from the *DISP* (display) screen to the *SET* (setup) screen:

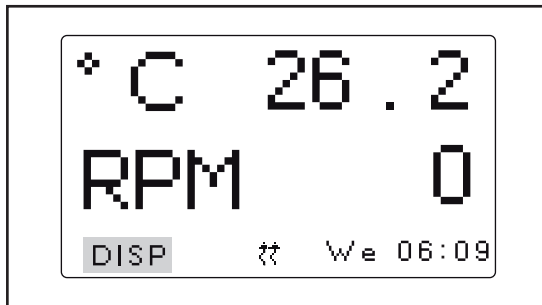

1. Turn the control knob to highlight *DISP* in the bottom-left corner of the screen.
2. Click the control knob in.
DISP will flash.

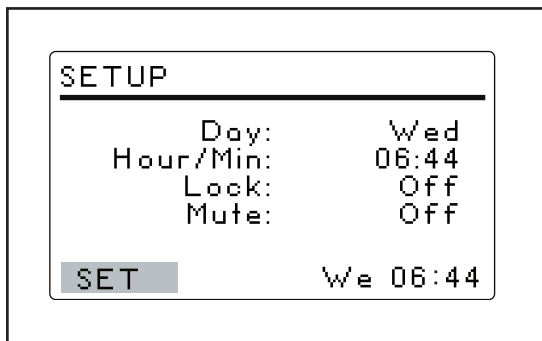

3. Turn the control knob to choose the *SET* screen.
4. Click the control knob in to save your selection.
You changed from the *DISP* screen to the *SET* screen.
5. Repeat the procedure to select any screen.

5.8 Display Screen

The *DISP* screen displays 2 parameters and the measured values. Use this screen to:

- Change displayed parameters
- View measured values
- View and change setpoints

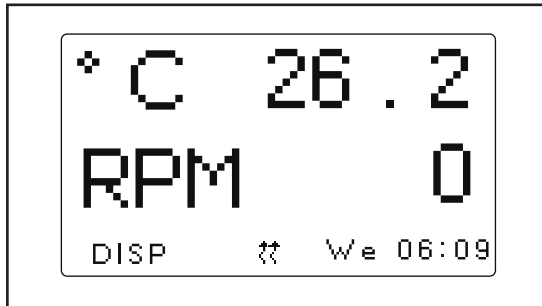
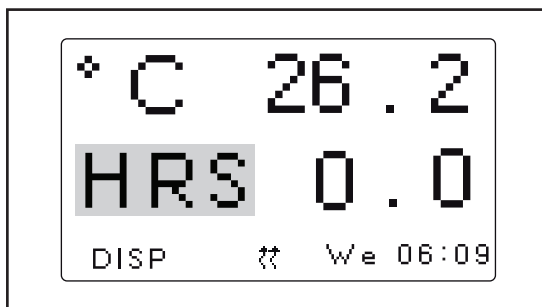

Fig. 5-2: Display screen

5.8.1 Changing displayed parameters



1. Turn control knob to highlight the parameter you wish to replace. For this example, we will change the parameter *RPM* to *HRS*.
2. Click the control knob in.
RPM will flash.



3. Turn the control knob until the desired parameter appears in the highlighted field.
4. Click the control knob in to save the parameter.



- If you do not click the control knob to save your selection, after a few seconds the screen will revert to its previous settings.

5.8.2 Viewing the setpoints

You can verify the setpoints in the *DISP* screen. The parameter values displayed are the measured values. The setpoint values are user-selected. They may differ depending on many variables.

Operation

New Brunswick Innova® 43/43R Shaker
English (EN)

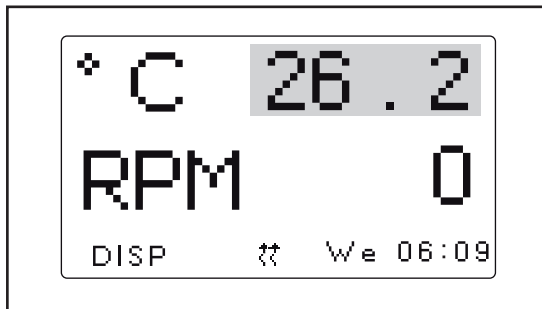

1. Turn the control knob to highlight the actual (measured) parameter value.
2. Click the control knob in to display the setpoint. The setpoint will flash.
3. Click the control knob in again to return to normal display.

5.8.3 Changing the setpoints

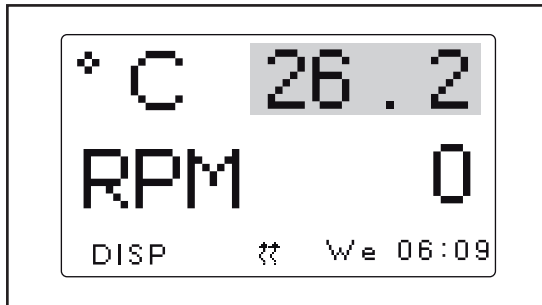

1. Use the control knob to highlight the measured (actual) value (26.2 °C in figure).
2. Click the control knob in. The setpoint will flash.

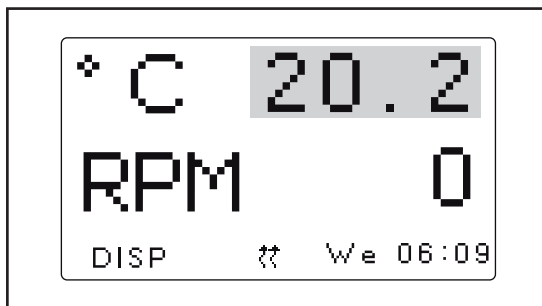

3. Turn the control knob to change the setpoint to desired value (20.2 °C in figure). The control knob will change by increments of (0.1 °C). If you spin the control knob quickly, the value will change by larger increments.
4. Click the control knob in to save the new setpoint. The display will automatically return to the measured actual value.



- If you highlight an item, change it, but do not save your selection, after a few seconds the screen will revert to its previous setting.

5.9 Summary screen

In the *SUMM* (summary) you can see both the current *ACTUAL* (measured) values and the *SET* points for shaking speed (*RPM*), chamber temperature (*°C*), elapsed time in a programmed run (*HRS*) and, if you are using the optional humidity monitor, the percentage of relative humidity (*%RH*).



- *ACTUAL* values are the current measured values in the shaker. You cannot change the values on the screen.
- *SET* values are the values the user selects.

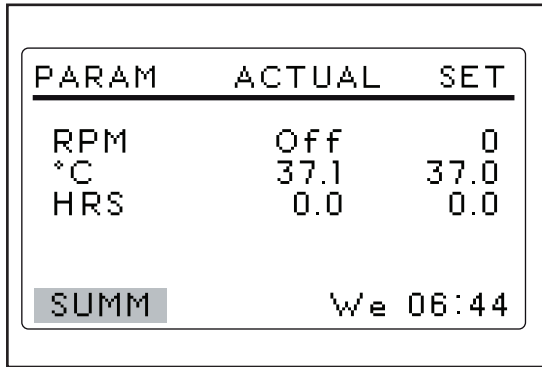
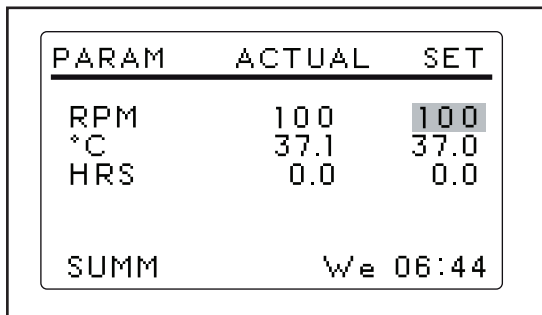

Fig. 5-3: Summary screen

5.9.1 Changing setpoint values in the summary screen

Like in the *DISP* screen, you can change the setpoints in the *SUMM* screen:



1. Turn the control knob to select the desired setpoint. For this example, we will highlight *100* to change the *RPM* setpoint.
2. Click the control knob in. Setpoint value will flash.

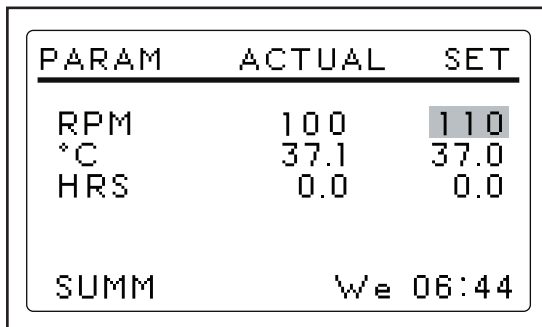

3. Turn the control knob clockwise to increase the value or turn counter-clockwise to decrease the value. For this example we will change the setpoint from *100* to *110*. Click the control in to save the new setpoint value.
4. Repeat the procedure to change the other setpoint values.



- If you turn the control knob but do not save the setpoint value, after a few seconds the screen will revert to its previous settings.

5.10 Setup screen

In the *SET* (setup) screen you can set the day of the week and the time (on a 24 h clock). This screen also allows you to lock all of your settings from further changes, and to mute or enable the audible alarm.

Operation

New Brunswick Innova® 43/43R Shaker
English (EN)

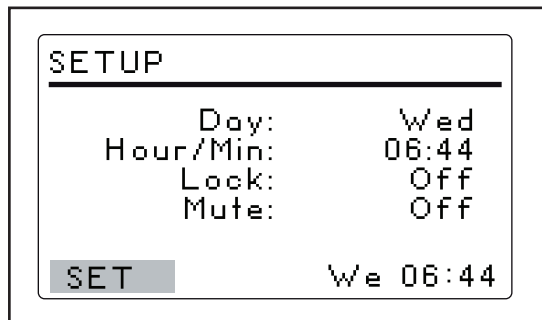

Fig. 5-4: Setup screen

5.11 Communication/RS-232 screen

This *COMM* screen (communication) is used if you have connected a PC to the RS-232 port. Use this screen to:

- Select the RS-232 port *Mode*.
- Select the *Baud Rate* appropriate to your PC.

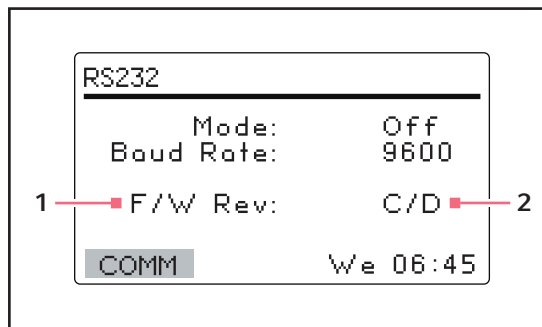

Fig. 5-5: Communication screen

- 1 FirmWare Revision (this line is for information only).** **2 In this sample screen, the Display is at Revision C and the FirmWare Control Board at Revision D.**

5.11.1 Changing the communication mode

In the *RS-232* screen:

1. Turn the control knob to highlight the *Mode* status.
2. Click the control knob in.
The current setting will flash.
3. Turn the control knob to select make your selection.
4. Click the control knob in to save your setting.

Tab. 5-2: Communication mode

Mode	Application
<i>Off</i>	The RS-232 is not open to communication in either direction
<i>Slave</i>	The shaker can be fully controlled from the computer
<i>Talk</i>	The shaker sends current value reports to the computer once per minute
<i>Monit (Monitor)</i>	The shaker responds only to <i>Report Requests</i>

5.11.2 Changing the baud rate

In the *RS-232* screen:

1. Turn the control knob to highlight the current setting.
 The settings are: *9600*, *19200*, and *38400*.
2. Click the control knob in.
 The current setting will flash.
3. Turn the control knob left or right until the desired setting appears: *9600*, *19200* or *38400*.
 The setting you choose should match the baud rate of your computer.
4. Click the control knob in to save your selection.

5.12 Calibrate screen

Use the *CAL* (calibrate) screen to:

- Create a temperature offset (see *Setting temperature offset on p. 44*).
- Calibrate shaking speed (see *Calibrating speed on p. 44*).

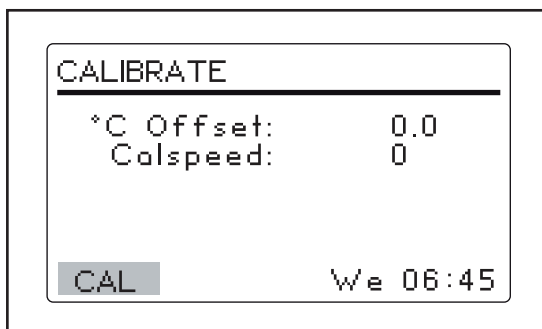

Fig. 5-6: Calibrate (CAL) screen

Operation

New Brunswick Innova® 43/43R Shaker
English (EN)

5.13 Programs screen

Use the *PROG* screen to program steps for the shaker. The resident software for the Innova 43/43R Shaker can store up to 4 programs, each having as many as 15 steps. Each step can be programmed in 1 min increments, for total periods of 0 hr 1 min – 99 hr 59 min.

To enter the programming mode, use the control knob to select the *PROG* screen.

In the *PROG* screen you can:

- *Run* a program
- Create a *New* program
- *Edit* a program
- Turn *Off* a program

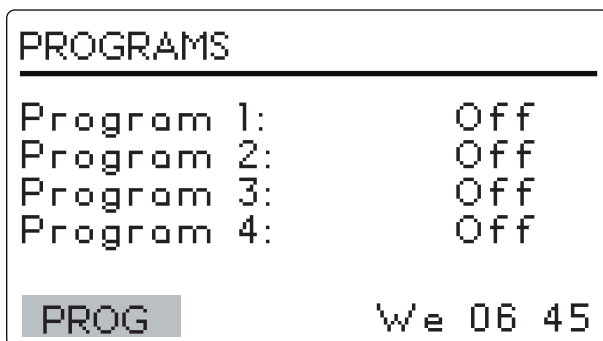
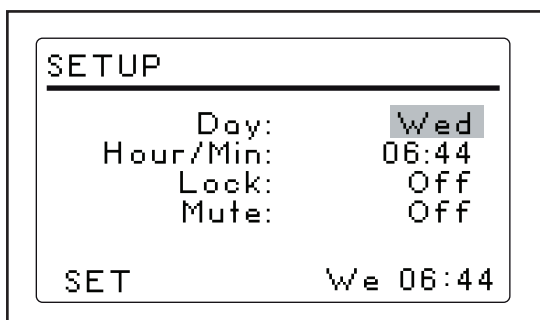

Fig. 5-7: Program screen

5.14 Changing the day

In the *SET* screen:



1. Turn the control knob to highlight the day (*Wed* in figure).
2. Click the control knob in.
The day will flash.
3. Turn the control knob to select a different day.
4. Click the control knob in to save your selection.



- If you do not click the control knob to save your choice, after a few seconds the screen will revert to its previous settings.

5.15 Changing the time

In the *SET* screen:

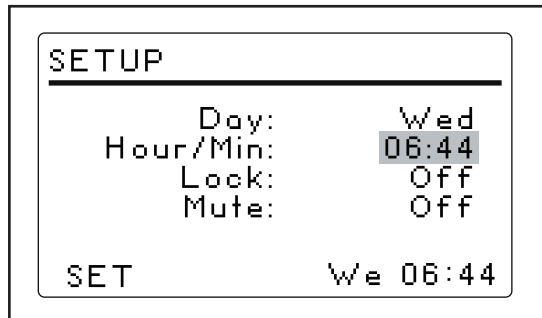

1. Turn the control knob to highlight the time.
2. Click the control knob in.
The time (06:44) will flash.
3. Turn the control knob clockwise or counterclockwise to select a different time. Clockwise moves the time forward, counterclockwise moves the time back. One click clockwise or counterclockwise will move the time in 1 min increments. Turning the control knob faster will change the time more rapidly.
4. Click the control knob in to save your selection.

5.16 Locking the settings

In the *SET* screen:

1. Turn the control knob to highlight the *Lock* status.
2. Click the control knob in.
The current status of the *Lock* (*On* or *Off*) will flash.
3. Turn the control knob to select *On* or *Off*.
4. Click the control knob in to make a selection.
When you select *On*, the Lock icon will appear at the bottom of the screen. This icon will remain on display on all screens until you turn the Lock function *Off*.

5.17 Mute the audible alarm

In the *SET* screen:

1. Turn the control knob to highlight the *Mute* status (*On* or *Off*).
2. Click the control knob in.
The current status of the alarm (*On* or *Off*) will flash.
3. Turn the control knob to select *On* or *Off*.
4. Click the control knob in to save your selection.
When you set *Mute* to *On*, the mute icon will appear at the bottom of the screen. This icon will be displayed on all screens until you turn *Mute* to *Off*.

Operation

New Brunswick Innova® 43/43R Shaker
English (EN)

5.18 Temperature offset calibration

The temperature probe and the temperature controller are calibrated together at the factory.

- The temperature probe measures the temperature of the air at the probe's location, near the return vent.
- The controller uses the probe input to adjust air temperature, up or down, to match the temperature setpoint.

The display temperature may differ from temperatures within the flasks themselves, based on:

- Flask placement and size
- Heat produced by growing organisms
- Heat losses due to liquid evaporation from flasks
- Etc.

If you wish to have the temperature display (indicated temperature) match the temperature at a given point, or match the average of a series of points within the chamber (actual temperature):

1. Let the unit equilibrate at or near the desired temperature, then record the indicated temperature.
2. Record the actual temperature.
3. Calculate the temperature correction value using the following formula:

$$\text{actual temperature} - \text{indicated temperature} = \text{temperature offset value}$$

5.19 Setting temperature offset

To set the temperature calibration offset:

1. Use the control knob to enter the *CAL* screen.
2. Turn the control knob to highlight the current setting and click the knob in.
The current setting will flash.
3. Turn the control knob clockwise or counterclockwise to display the desired setting.
As you turn the control knob, each click represents 1/10 °C (0.1 °C).
4. Once you reach the desired setting, click the control knob in to save the new value.
When the temperature offset is set to any value other than 0, the icon indicating temperature offset will appear next to °C in the *DISP* and *SUMM* screens.



If you highlight and change an item but do not save your selection, after a few seconds the screen will revert to its previous setting.

5.20 Calibrating speed

The Calspeed function, which is set in the *CAL* screen, is used to calibrate the speed of the shaking mechanism.

The speed is calibrated at the factory, and does not require recalibration until a major operating component (e.g., drive belt) is changed.

 Prior to calibrating the speed, make sure that the platform is properly secured to the subplatform, and any flasks present are secured.

When the shaker is running, the *CAL* screen shows the indicated rpm value. If you wish to calibrate the speed, set the speed to a value that can be easily measured.

 250 rpm is recommended.

If, after measuring the actual speed, you wish to adjust the indicated value:

1. Click the control knob in.
2. Set the new value.
3. Click the control knob in again to save the setting.
4. Turn the shaker off, wait a few seconds, then turn the shaker back on.

5.21 Program steps

The resident software for the Innova 43/43R can store up to 4 programs, each having as many as 15 steps. Each step can be programmed into 1 min increments, for total periods of 1 min up to 99 hr 59 min each.

To enter the programming mode, use the control knob to select the *PROG* screen. At this point, you can run a program, edit a program, generate a new program or turn a program off.

Off is the default mode.

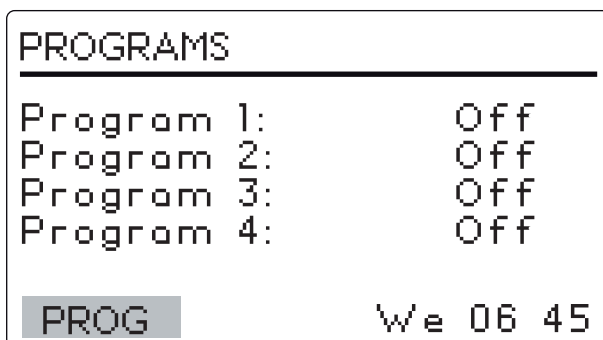

Operation

New Brunswick Innova® 43/43R Shaker
English (EN)

5.22 Creating a program

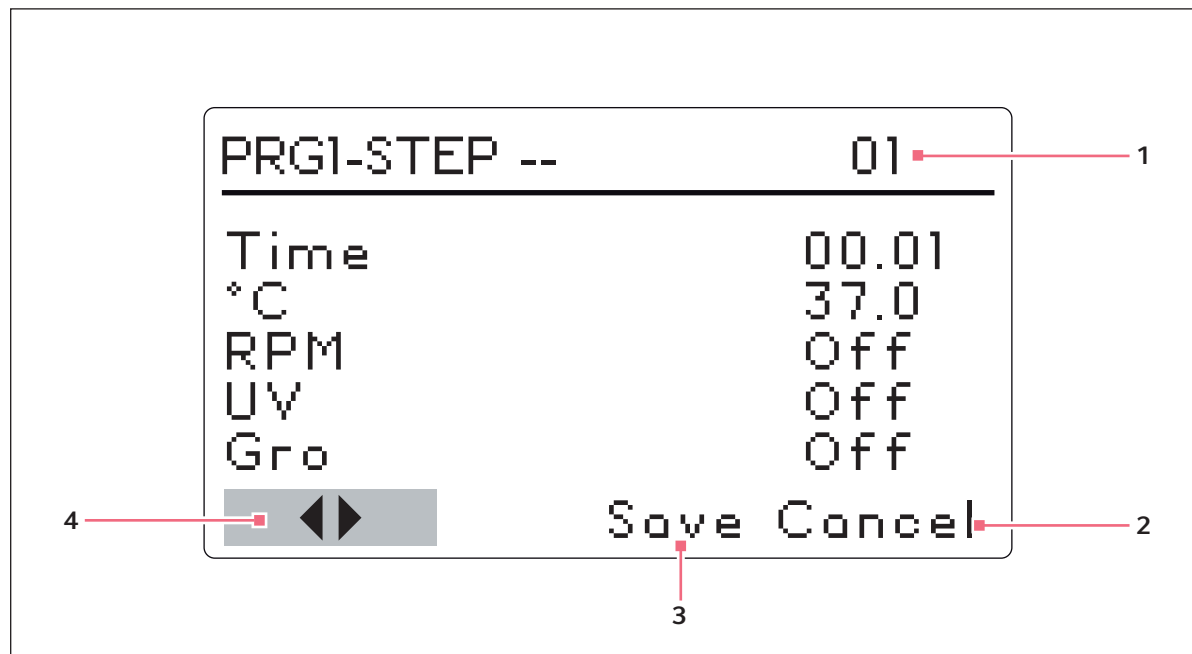

Fig. 5-8: Creating a program

1 Step number**3 Save**

DO NOT USE until programming is complete

2 Cancel

Used to leave Programming mode without saving any new settings

4 Use these arrows to scroll through steps

To create a new program:

1. Use the control knob to highlight the mode of Program 1, then click the control knob in.
The selected field will begin to flash.

2. Turn the control knob until the field says *New*.

3. Click the control knob in to select this mode.



If your shaker is not equipped with the optional UV or Photosynthetic lights, *UV* and *GRO* will appear with the word *Off* in this screen, but will not be programmable.

The screen for *Program 1 - Step -- 01* will open.

4. Turn the control knob to highlight the time setting, then click it in.

The field will flash.

5. Turn the control knob until the desired running duration for this step (00:01 min – 99:59 h) appears.
6. Click the control knob in to save the setting.
7. Turn the control knob to highlight the °C temperature setting, then click it in.

The field will flash.

8. Turn the control knob to set the temperature desired (4.0 °C – 80.0 °C) for the set time period.
9. When the desired value appears, click the control knob in to save the setting.
10. Turn the control knob to highlight the rpm setting, then click it in.

The field will flash.

11. Turn the control knob to select the desired shaking speed (25 rpm – 400 rpm) for this time period.
12. Click the control knob in to save the setting.

If your unit is equipped with either the optional GRO lamp or UV lamp, and you wish to have them on during the time period you have set: (see *Programming the UV lamp on on p. 47*)(see *Programming the GRO lamp on on p. 48*)

13. To program Step 2, use the control knob to highlight the arrows at the bottom left of the screen.
14. Click the control knob to make the arrows flash.
15. Turn the control knob clockwise until *Step 02* appears.
16. Click the control knob in to work in this screen, and repeat steps 5 – 12.



Whatever step is shown on the right-hand side of the display is settable. To scroll between steps, select the arrows (bottom left), then turn the control knob to the desired step.



The time entered for each step is for that step ONLY. It is not cumulative (i.e., the elapsed time from the start of the program).

17. Continue to program as many as 15 steps in the same manner.

Please note that temperature reductions, even at temperatures above ambient (from 40 °C – 30 °C, for example), require refrigeration to be effective.

To save entire program:

1. Once all steps are set, use the control knob to highlight *Save* at the bottom of the screen, then click the control knob in. The field will flash.
Click the control knob in again to save the program. The display will read *Process Running - Saving File* for a few seconds, then return to the main *Programs* screen.

If you wish, you can set Programs 2, 3, and 4 by following the same procedure.

5.23 Programming the UV lamp on

1. Use the control knob to select the field.
2. Click the control knob in to save the field (it will flash).
3. Use the control knob to select *On*.
4. Click the control knob in to save the setting.

Operation

New Brunswick Innova® 43/43R Shaker
English (EN)

5.24 Programming the GRO lamp on

1. Use the control knob to select the field.
2. Click the control knob in to save the field (it will flash).
3. Use the control knob to select On.
4. Click the control knob in to save the setting.

5.25 Edit a program

Use the *Edit* mode to open a program you have already created and saved, in order to modify your settings following the same procedures for creating a program (see *Creating a program on p. 46*).

5.26 Running a program

Use the *Run* mode to turn a specific program on. Only 1 program can run at a time. When you change the mode to *Run*, the screen will show the *Run* icon.

PROGRAMS	
Program 1	Run
Program 2	Off
Program 3	Off
Program 4	Off
PROG	⚙ We 06 47

To stop a program, change the program mode to *Off*.

5.27 Program the timer

By setting an *HRS* setpoint in the *DISP* or *SUMM* screen, the shaker may be set to automatically stop after a preset time period of 0 hr 1 min – 99 hr 59 min.

If the time is set to *0:00*, the shaker will operate continuously until either the lid is opened or the START/STOP switch is pushed.

5.28 Filling the spill pan/water reservoir

If your unit is equipped with the factory installed humidity sensor, you may choose to use the spill pan as a water reservoir to reduce evaporation and raise the humidity level in the chamber.

To fill the spill pan/water reservoir:

1. Open the lid and temporarily remove the platform.
2. Make sure the drain valve is closed.
3. Slowly fill the pan/reservoir with no more than 3 L of water.



The pan/reservoir can be accessed from the left, right, or in front of the spill cover. As you add water, do not allow the water to splash or flow into the recessed middle of the pan, where the bearing housing assembly is mounted. Pour water **very slowly** into the shallow area beyond the edge of the spill cover to protect the bearing housing.



A long, narrow watering can or flexible hose will make it easier to access the pan/reservoir while protecting the bearing housing from accidental overflow.

At a 37 °C setpoint, the chamber loses approximately 500 mL/hr from the pan.

At a 25 °C setpoint, and placed in a 25 °C room, the chamber achieves a relative humidity equilibrium that is approximately 15 % above the ambient humidity.

5.29 Draining the spill pan/water reservoir

To drain the spill pan/water reservoir:

1. Attach the quick-connect drain fitting.
2. Direct it to a container or drain, and allow the water to gravity drain.
3. When the reservoir is empty, detach the fitting.

The spill pan/water reservoir drain is located in the front of the unit, on the left, under the humidity tray.

5.30 Mains/Power interruption and fault interruption

In the event of a power failure, the Innova 43/43R Shaker is equipped with an automatic restart function. The shaker's non-volatile memory retains all stored information.

If the shaker was in operation prior to the power interruption, the shaker will begin to operate at its last entered setpoints. The alarm *POWER* will flash on the display, indicating that a power interruption has occurred. Turn the control knob in any direction to acknowledge the visual alarm. The flashing will stop.

In the unlikely event of a mechanical shaking fault interruption, the Innova 43/43R Shaker display will flash an alarm and warn the user, indicating an alarm has occurred. In this mechanical shaking fault interruption, the shaker will not restart the shaking function.

The incubator/shaker will not operate shaking until the alarm is, acknowledged, and shaking is manually restarted from the controls at the last entered setpoints.

Operation

New Brunswick Innova® 43/43R Shaker
English (EN)

6 Remote programming

You can use a communications program (such as HyperTerminal) to send commands to the shaker from your PC.



- HyperTerminal is not included with Windows® Vista or Windows 7.

6.1 HyperTerminal

Before setting up communication software, check the Mode and Baud Rate parameter settings found on the RS-232 screen of the shaker (see *Communication/RS-232 screen on p. 40*).

- Set the Mode parameter of the shaker to Slave
 - Set the appropriate Baud Rate (The default setting is 19200. Your other choices are 9600 or 38400.)
1. Connect the RS-232 cable between your computer and the shaker's **RS-232 port**.
 2. Start HyperTerminal and follow the steps for *Setting a New Connection*.
 3. Select the COM port you will be using.
 4. Set the COM parameters to the following values:

Baud rate	Enter the setting on your shaker
Data bits	8
Parity	None
Stop bits	1
Flow control	None

6.2 Testing the connection

1. Turn the shaker off.
2. Start HyperTerminal.
3. Turn the shaker on.

If a connection is made, the shaker will send an *OK* to the communication software.

6.3 Sending commands

With the command program, the user sends commands to the Innova 43/43R Shaker by computer.

- The serial interface uses an echo character protocol that is implemented to indicate that a valid character has been received by the shaker.
- For every character sent by the user computer, the Innova 43/43R Shaker will return a matching character.
- This echo character should be read by the computer and compared to the character that was sent.

Remote programming

New Brunswick Innova® 43/43R Shaker
English (EN)



- When sending a command in HyperTerminal, do not allow the pause between any 2 characters of your message to last longer than 10 s.
- After 10 s the shaker's serial port will reset itself.

This is the command set format:

<Command><Space><Arg1><Space><Argn><CR>

- Most commands are defined as 2 capital characters using the ASCII character set (see *Index to command codes on p. 56*).
- If a command has several arguments (Argn), the ASCII space control character separates each argument.
- The command is sent using the ASCII carriage return (CR) control character.
- The line feed control character may also be included but must follow the carriage return character.

When a command is sent that returns data, the characters returned are in ASCII format. Each additional argument returned will be separated by the ASCII space or tab control character. Refer to the selected command for the actual format. Data returned is terminated with a carriage return line feed control character sequence.

6.3.1 Example: Commanding set speed

In the following example, the computer will set the shaker speed to 250 rpm:

- ▶ In HyperTerminal, type **CS<Space>250<CR>**.

The shaker echos **CS<Space>250<CR>**

The shaker is set to 250 rpm



Do not actually type the angled brackets. <Space> means press the space bar <CR> means press the carriage return.

6.3.2 Example: Requesting measured values

- ▶ Type **RV<CR>**.

The shaker echos **RV<CR>**

The shaker will report:

- Arg1 (Speed rpm)
- Arg2 (Temperature °C)
- Arg3 (Humidity %)
- Arg4 (CO₂ %)
- Arg5 (Grow lamp 0 = Off, 1 = On)
- Arg6 (UV lamp 0 = Off, 1 = On)

These values will be separated by <Tab>.

This will look like:

250 29 90 0 0 0

6.4 Set Commands

Code	Meaning	Command format	Return data
CS	Command speed	CS <Space><Arg1><CR>	<ul style="list-style-type: none"> • Arg1 = Speed setpoint
CT	Command temperature	CT <Space><Arg1><CR>	<ul style="list-style-type: none"> • Arg1 = Temperature setpoint

6.5 Program control commands

Code	Meaning	Command format	Return data
PC	Clear program (clears program steps)	PC <Space><Arg1><Space><Arg2><CR> Note: If Arg2 is not included, all 15 steps of selected program will be cleared.	<ul style="list-style-type: none"> • Arg1 = Program number (1 – 4) • Arg2 = Step number (1 – 15)
PM	Program mode (returns status of current program run/hold mode)	PM <CR>	<ul style="list-style-type: none"> • Arg1 = Run/hold status (0 = end, 1 = run) • Arg2 = Program number (1 – 4) • Arg3 = Step number (1 – 15) Note: If a program has not been selected to run, a 0 will be returned for program number and step number

Remote programming

New Brunswick Innova® 43/43R Shaker
English (EN)

Code	Meaning	Command format	Return data
PR	Read program step in memory	PR <Space><Arg1><Space><Arg2><CR>	<ul style="list-style-type: none"> • Arg1 = Profile number (1 – 4) • Arg2 = Step number (1 – 15) <p>Note: if ARG2 = * (asterik) all steps returned</p> <ul style="list-style-type: none"> • Arg9 = Grow lamp (0 = off, 1 = on) • Arg8 = UV lamp (0 = off, 1 = on) • Arg7 = Step minutes (0 – 59) • Arg6 = Step hours (0 – 99) • Arg5 = CO₂ setpoint % (future option, returns 0.0) • Arg4 = Speed setpoint rpm • Arg3 = Temperature setpoint °C
PS	Program stop/start (stops or starts a program)	<p>PS<CR> With no other parameters, any program currently running will be stopped.</p> <p>PS<Arg1><Space><Arg2><CR></p>	<ul style="list-style-type: none"> • Arg1 = Program number (1 – 4) • Arg2 = Step number (1 – 15) <p>Note: If Arg2 is not included, the program will start in Step 1.</p>

Code	Meaning	Command format	Return data
PW	Write Program step to memory	PW <Space><Arg1><Space>...<Arg7><CR>	<ul style="list-style-type: none"> • Arg1 = Program number (1 – 4) • Arg2 = Step number (1 – 15) • Arg3 = Temperature setpoint °C • Arg4 = Speed setpoint rpm • Arg5 = CO₂ setpoint % • Arg6 = Step (0 – 99) • Arg7 = Step min (0 – 59)

6.6 Report request commands

Code	Meaning	Command format	Return data
RI	Report software version	RI <CR>	<ul style="list-style-type: none"> • Arg1 = Display module software version • Arg2 = Control module software version
RP	Report parameter list (ASCII text header)	RP <CR>	<ul style="list-style-type: none"> • Arg1 = Speed rpm • Arg2 = Temperature °C • Arg3 = CO₂ %
RV	Report setpoint values	RS <CR>	<ul style="list-style-type: none"> • Arg1 = Speed rpm • Arg2 = Temperature °C • Arg3 = CO₂ % • Arg4 = % Relative humidity • Arg5 = Grow lamp status • Arg6 = UV lamp status
RS	Report measured values	RV <CR>	

6.7 Set/get date and time commands

Code	Meaning	Command format	Return data
=D	Set date and time	=D <Space><Arg1><Space><Arg2>...<Arg7><CR>	

Remote programming

New Brunswick Innova® 43/43R Shaker
English (EN)

Code	Meaning	Command format	Return data
?D	Get date and time	?D<CR> <Arg1><Tab><Arg2><Tab><Arg3><Tab>...<Arg7><CR><LF>	<ul style="list-style-type: none"> • Arg1 = Hours (0 – 23) • Arg2 = Minutes (0 – 59) • Arg3 = Seconds (0 – 59) • Arg4 = Year (00 – 99) • Arg5 = Month (01 – 12) • Arg6 = Date (1 – 31) • Arg7 = Day (1 – 7) <ul style="list-style-type: none"> – 1 = Monday – 2 = Tuesday – 3 = Wednesday – 4 = Thursday – 5 = Friday – 6 = Saturday – 7 = Sunday

For example, the following command:

```
=D<Space><01><Space><30><Space><00><Space><04><Space><07><Space><04><Space><07><CR>
```

Will set the real date and time on your shaker to:

1:30:00 am, 2004, July 4, Sunday.

6.8 Index to command codes

Tab. 6-1: Command codes

Command Code	Meaning
CL	Command Grow Lamp
CS	Command Speed
CT	Command Temperature
CU	Command UV Lamp
PC	Clear Program
PM	Program Mode
PR	Read Program Step in memory
PS	Program Stop/Start
PW	Write Program Step to memory
RI	Report Software Version
RP	Report Parameter List
RS	Report Setpoint Values
RV	Report Measured Values

Command Code	Meaning
=D	Set Date and Time
?D	Get Date and Time

Remote programming

New Brunswick Innova® 43/43R Shaker
English (EN)

7 Troubleshooting

7.1 Troubleshooting

If any problems occur with your shaker, do not attempt to perform any service on the unit other than specified in this manual. Please contact your local Eppendorf customer service department for assistance.

In any correspondence with Eppendorf, please refer to the model number and serial number of your unit. This information is on the electrical specification plate, located on the rear panel of the unit, above the power connector.

There are some problems, however, that you can investigate and correct yourself. Please refer to the following troubleshooting guide:

Symptom	Cause	Solution
Shaker does not run	• Power cord is not plugged in	▶ Plug in power cord to working mains/power outlet
	• Lid is ajar	▶ Ensure lid is closed firmly
	• Defective main board • On/Off switch is broken • Lid switch is broken • Defective display board • Jammed shaking mechanism • Defective motor • Drive belt out of alignment or worn	▶ Call for service
	• Shaking speed has been set to 0 by program running or by computer interface	▶ Reset shaking speed (see <i>Changing setpoint values in the summary screen on p. 39</i>)
	• Improperly installed fuse	▶ Remove and reinstall fuse
Shaker runs slowly and/or there is no speed indication	• Improperly installed fuse • Fuse is burned out	▶ Remove and reinstall fuse
	• Incorrect speed calibration	▶ Recalibrate shaking speed (see <i>Calibrating speed on p. 44</i>)
	• Defective main board • Defective motor • Drive belt out of alignment or worn	▶ Call for service

Troubleshooting

New Brunswick Innova® 43/43R Shaker
English (EN)

Symptom	Cause	Solution
Shaker does not run at set speed	<ul style="list-style-type: none"> • Shaker is running in Program mode (look for Run icon in display) • Shaker speed has been changed by RS-232 command or computer interface 	▶ Check display
	<ul style="list-style-type: none"> • Shaker is overloaded and/or you are using baffled flasks 	▶ Remove some contents and balance load
	<ul style="list-style-type: none"> • Defective motor • Drive belt out of alignment or worn 	▶ Call for service
	<ul style="list-style-type: none"> • Speed not calibrated correctly 	▶ Check speed calibration (see <i>Calibrating speed on p. 44</i>)
Excessive operating noise	<ul style="list-style-type: none"> • Load out of balance 	▶ Unload all contents and reload
	<ul style="list-style-type: none"> • Loose components in platform, subplatform, and/or drive assembly 	▶ Call for service
Shaker does not reach set temperature	<ul style="list-style-type: none"> • Shaker is running in Program mode (look for Run icon in display) • Shaker speed has been changed by RS-232 command/ computer interface • Line voltage is too low 	▶ Check display
	<ul style="list-style-type: none"> • Heater fuse blown • Compressor fuse blown 	▶ Replace fuse
	<ul style="list-style-type: none"> • Compressor over-pressure switch activated • Defective heater • Defective refrigeration system • Defective heater • Defective refrigeration system 	▶ Call for service
	<ul style="list-style-type: none"> • Ambient temperature too high or too low 	▶ Adjust the room temperature
	<ul style="list-style-type: none"> • Lid is not completely closed (even though Open Lid icon may not appear on display) 	▶ Open and reclose it firmly
	<ul style="list-style-type: none"> • Frequency on line voltage is set incorrectly 	▶ Reset line voltage frequency
	<ul style="list-style-type: none"> • Incorrect temperature indication 	▶ See <i>Incorrect temperature indication</i> section of this table

Symptom	Cause	Solution
Incorrect temperature indication	<ul style="list-style-type: none"> • Temperature Offset has been programmed 	<ul style="list-style-type: none"> ▶ Look for Offset icon in display
	<ul style="list-style-type: none"> • Defective RTD assembly • Defective main board • Defective humidity probe or broken contact 	<ul style="list-style-type: none"> ▶ Call for service
Incorrect relative humidity %	<ul style="list-style-type: none"> • Defective humidity probe • Broken contact 	<ul style="list-style-type: none"> ▶ Call for service
Photosynthetic GRO lamp does not work	<ul style="list-style-type: none"> • Shaker is running in Program mode (look for Run icon in display), and program calls for GRO lamp to be off • GRO lamp mode has been changed by RS-232 command/ computer interface 	<ul style="list-style-type: none"> ▶ Check display
	<ul style="list-style-type: none"> • Bulb is burned out • Fuse is burned out 	<ul style="list-style-type: none"> ▶ Replace
		<ul style="list-style-type: none"> ▶ Check switch settings ▶ Check cable connections ▶ Check ballast voltage
UV germicidal lamp does not work	<ul style="list-style-type: none"> • Shaker is running in Program mode (look for Run icon in display), and program calls for UV lamp to be off • UV lamp mode has been changed by RS-232 command/ computer interface 	<ul style="list-style-type: none"> ▶ Check display
	<ul style="list-style-type: none"> • UV lamp is burned out • Fuse is burned out 	<ul style="list-style-type: none"> ▶ Replace
		<ul style="list-style-type: none"> ▶ Check switch settings ▶ Check cable connections ▶ Check ballast voltage

Troubleshooting

New Brunswick Innova® 43/43R Shaker
English (EN)

8 Maintenance

8.1 Routine maintenance



WARNING! Personnel injury and equipment damage!

- ▶ When cleaning the unit, always turn off the shaker and disconnect the power cord from the power supply.
-

We recommend you occasionally wipe down the shaker with a non-abrasive household cleaner.

We also suggest that the area around the shaker be vacuumed or swept to remove dust and other debris, ensuring proper air flow in and around the shaker.

8.2 Cleaning external and internal surfaces



WARNING! Personnel injury and equipment damage!

- ▶ When cleaning the unit, always turn off the shaker and disconnect the power cord from the power supply.
-

The unit may be cleaned using a damp cloth or any standard household or laboratory cleaner to wipe down its outer surfaces. Do not use abrasive or corrosive compounds to clean this instrument, as they may damage the unit.

8.3 Biohazard decontamination

It is the responsibility of the user to carry out appropriate decontamination procedures if hazardous material is spilled on or inside the equipment. Before using any cleaning or decontamination method other than those suggested by the manufacturer, users should check with Eppendorf that the proposed method would not damage the unit.

Commercially available household bleach solutions, when diluted at a 1:10 ratio, are effective in routine decontamination of the instrument. The method for decontaminating a spill depends upon the nature of the spill.

Spills involving fresh cultures or samples known to have low concentrations of biomass should be flooded with decontamination solution and soaked for 5 min before cleanup. Spills involving samples with high concentrations of biomass, or involving organic matter, or occurring in areas warmer than room ambient temperature, should be exposed to decontamination solution for at least 1 hour before cleanup.

Maintenance

New Brunswick Innova® 43/43R Shaker
English (EN)

**WARNING! Injury from hazardous biological material!**

- ▶ Use respiratory protection when cleaning spills where aerosolization is suspected.
 - ▶ Wear gloves, safety glasses, and laboratory coat when cleaning.
-

9 Technical data

9.1 Specifications



The use of baffled flasks will significantly reduce maximum speed for any shaker.

These specifications assume that load and speed that are consistent with load and speed graphs, (see *Load and speed graphs on p. 67*).

9.1.1 Shaking

Speed	<ul style="list-style-type: none"> • 2.5 cm (1 in) orbit: 25 rpm – 500 rpm • 5.1 cm (2 in) orbit: 25 – 300 rpm
Control accuracy	<ul style="list-style-type: none"> • ± 1 rpm
Stroke	<ul style="list-style-type: none"> • 2.5 cm (1 in) • 5.1 cm (2 in)
Indication	<ul style="list-style-type: none"> • Displayed in 1 rpm increments
Alarm signal	<ul style="list-style-type: none"> • ± 5 rpm
Drive mechanism	<ul style="list-style-type: none"> • Triple-eccentric counterbalanced drive • 9 permanently lubricated ball bearings • Poly-V belt • Self-calibrating • Solid-state brushless DC motor
Safety	<ul style="list-style-type: none"> • Drive interrupt shuts off power to shaker when lid is opened • Acceleration/deceleration circuit prevents sudden starts and stops, minimizing both splashing and mechanical damage.

9.1.2 Temperature control

Heaters	<ul style="list-style-type: none"> • Low watt-density resistance heaters • High-temperature safety thermostat cut-out
Control accuracy	<ul style="list-style-type: none"> • ± 0.1 °C from 30 – 40 °C • ± 0.5 °C over the remaining range
Temperature range (Innova 43)	<ul style="list-style-type: none"> • 5 °C above ambient temperature to 80 °C
Temperature range (Innova 43R)	<ul style="list-style-type: none"> • 20 °C below ambient to 80 °C (minimum 4 °C) • Dependent on ambient temperature
Alarm signal	<ul style="list-style-type: none"> • ± 1 °C

Technical data

New Brunswick Innova® 43/43R Shaker
English (EN)

9.1.3 Power supply

Power supply	100 V \pm 10 %, 50 – 60 Hz 120 V \pm 10 %, 60 Hz 230 V \pm 10 %, 50 Hz	Innova 43: 800 VA Innova 43R: 1500 VA
--------------	--	--

9.1.4 Ambient conditions

Ambience	Only for use indoors
Ambient temperature	10 °C – 35 °C
Relative humidity	20 % – 80 %, non-condensing
Altitude	Up to 2000 m

9.1.5 Dimensions and weight

Space requirements	Width: 135.6 cm (53.5 in) Depth: 101 cm (40 in) Height: 162.7 cm (64.1 in)
Dimensions	Width: 115.6 cm (45.5 in) Depth: 81 cm (32 in) Height: 103 cm (40.6 in) Lid open height: 162.7 cm (64.1 in)
Chamber dimensions	Width: 87.6 cm (34.5 in) Depth: 61 cm (24 in) Height: 48 cm (19 in)
Platform dimensions	Width: 46 cm (18 in) Depth: 76 cm (30 in) (Select universal or dedicated styles)
Weight	Innova 43 weight: 209 kg (460 lb) Innova 43R weight: 231 kg (510 lb)

9.1.6 Photosynthetic lamps

Lamp type	T8 fluorescent lamp
Initial lumens	325 at 25 °C
Watts	15

9.1.7 Alarms

There is a visible and audible warning indication when:

- Speed deviates more than 5 rpm from high or low setpoints
- Temperature deviates more than ± 1 °C from high or low setpoints
- When timer has expired

Audible alarm can be muted.

9.1.8 Display

- 240 × 128 backlit LCD

9.1.9 RS-232

- Remote control
- Remote monitoring
- Remote data logging

9.1.10 Setpoint retention

- Operating setpoints are retained in non-volatile memory

9.1.11 Automatic restart

- After power is restored
- Indicated by flashing display

9.1.12 ETL regulatory standards

- UL 61010A-1
- UL 61010A-2-010
- CAN/CSA-C22.2 No. 1010.1
- CAN/CSA-C22.2 No. 1010.2.010

9.1.13 CE regulatory standards

For CE regulatory standards, (see *Declaration of conformity on p. 77*).

9.2 Load and speed graphs

The following graphs explain the maximum recommended shaking speed according to:

Technical data

New Brunswick Innova® 43/43R Shaker
English (EN)

- The load on the shaker's platform
- The diameter of the shaker's orbit (1 in or 2 in)

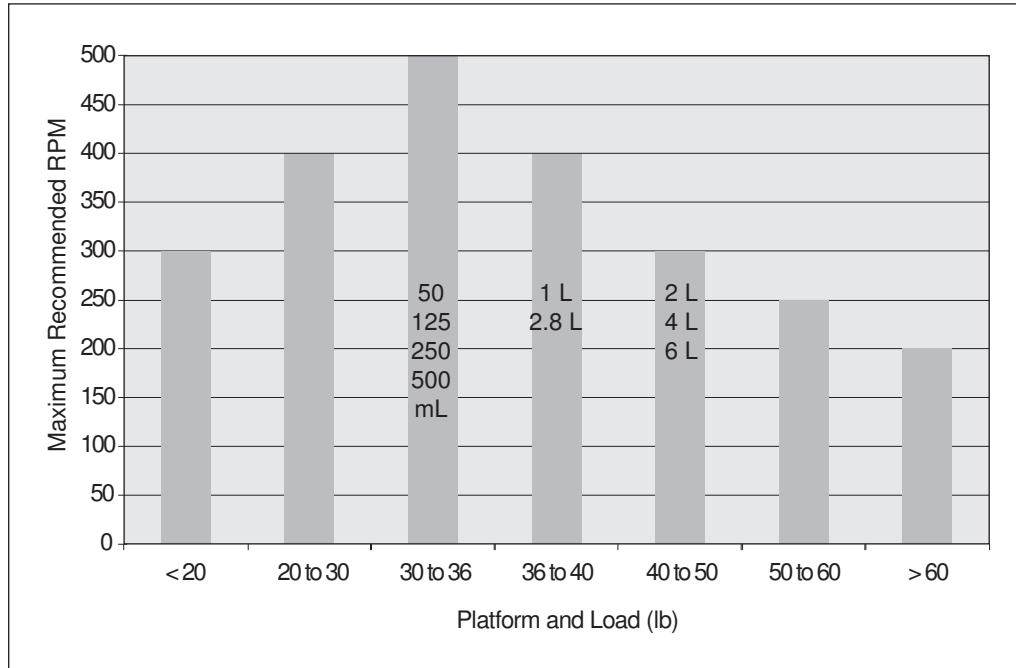

Fig. 9-1: Load and speed for 1 in orbit shakers (20 % full)

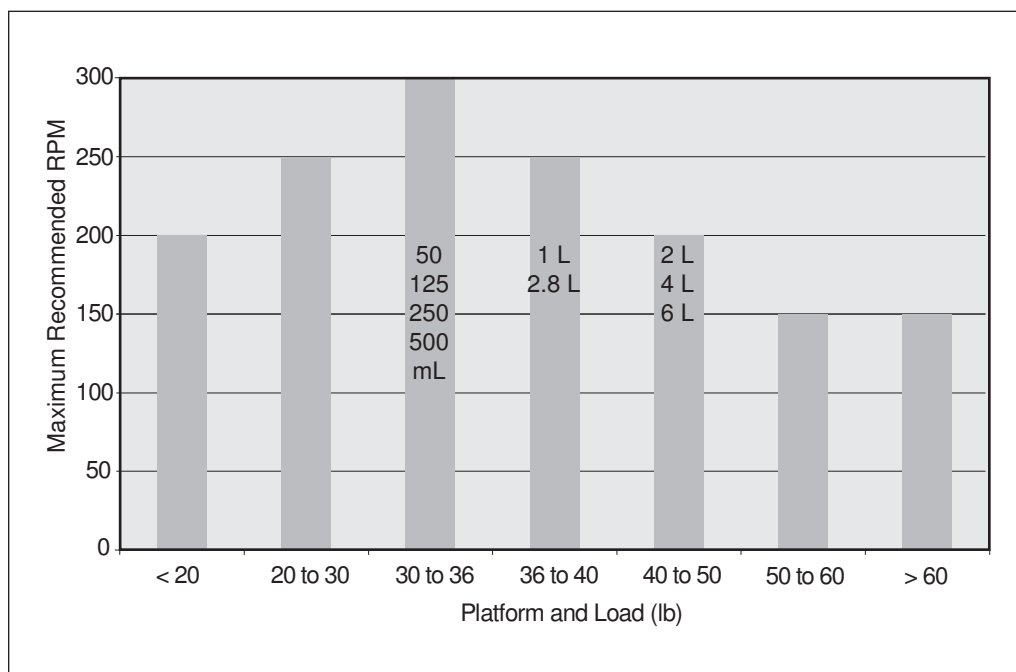

Fig. 9-2: Load and speed for 2 in orbit shakers (20 % full)

10 Ordering information

10.1 Replacement parts

For a list of replacement parts you may need for your Innova 43/43R Shaker, (see Tab. on p. 69).

Tab. 10-1: Spare parts kit (M1352-6000)

Description	Quantity	Part number
Spare parts kit, includes: <ul style="list-style-type: none"> • 1 motor drive poly-V belt • 2 each hinge assemblies • Halogen bulbs • (2) 10 A fuses • (2) 6.3 A fuses • (2) 3.15 A fuses 	1	M1320-6000
Spare parts kit, includes: <ul style="list-style-type: none"> • 1 motor drive poly-V belt • (2) 10 A fuses • (2) 6.3 A fuses • (2) 3.15 A fuses 	1	M1282-6000
Flask clamp screws, 10-24 x 5/16 in flat Phillips head (+)	25	S2116-3051
<ul style="list-style-type: none"> • Test tube rack screws, 10-24 x 1/2 in pan head • Washers (#10 plain, #10 lock) 	10 each	M1289-0080
Motor drive poly-V belt, 28 in long	1	P0700-7070
Fuse, 10 A	1	P0380-3162
Fuse, 6.3 A	1	P0380-3630
Fuse, 3.15 A	1	P0380-3460
Chamber lamp bulbs	2	P0300-0470
UV germicidal lamp (if equipped)	1	P0300-0351
Photosynthetic bulb (if equipped)	1	P0300-0221
UV germicidal light ballast (if equipped)	1	P0420-5113
Photosynthetic light ballast (if equipped)	1	P0420-5192

10.2 Accessories

When ordering accessories, you may be asked to provide the model number and serial number of your shaker. This information is on the electrical specification plate, located on the rear panel of the unit.

The serial number is also labeled in the lower right corner of the front panel, below the chamber lid seal.

Ordering information

New Brunswick Innova® 43/43R Shaker
English (EN)

**WARNING!**

- ▶ Do not use this equipment with accessories not provided or recommended by Eppendorf, or used in a manner not specified by Eppendorf and this manual. Protection provided by the equipment may be impaired and serious injury or death can occur.

10.2.1 Platforms

For a list of the the various solid 45.7 cm × 76 cm (18 in × 30 in) platforms available for your 43/43R Shaker, (see Tab. on p. 70).

Tab. 10-2: Platforms

Description	Part number
Universal platform	M1250-9920
50 mL Erlenmeyer flask dedicated platform	M1191-9908
125 mL Erlenmeyer flask dedicated platform	M1191-9909
250 mL Erlenmeyer flask dedicated platform	M1191-9910
500 mL Erlenmeyer flask dedicated platform	M1191-9911
1 L Erlenmeyer flask dedicated platform	AG-1
2 L Erlenmeyer flask dedicated platform	AG-2
2.8 L Erlenmeyer flask dedicated platform	AG-28
4 L Erlenmeyer flask dedicated platform	AG-4
6 L Erlenmeyer flask dedicated platform	AG-6

Universal platforms have multiple holes enabling you to mount an assortment of flask clamps or other accessories on a single platform. The capacities shown below represent the maximum number of flasks in a given size that will fit on the platform in a balanced pattern. Universal platforms, clamps and accessories are sold separately.

Dedicated platforms will come with flask clamps already mounted. Dedicated platforms generally will hold a greater number of flasks than the universal platform, but do not offer the versatility.

For a list of flask capacities for universal and dedicated platforms designated solely for 1 flask size, (see Tab. on p. 70).

Tab. 10-3: Flask capacities

Flask type	Dedicated platform capacity	Universal platform capacity
10 mL	--	183
25 mL	--	92
50 mL	108	92
125 mL	60	39

Flask type	Dedicated platform capacity	Universal platform capacity
250 mL	40	30
500 mL	24	18
1 L	15	12
2 L	12	8
2.8 L	6	6
4 L	6	6
5 L	--	6
6 L	4	4
Large test tube rack	--	7
Medium test tube rack	--	9
Small test tube rack	--	9
Microplate rack (stack)	--	16
Microplate rack (1 layer)	--	4

10.2.2 Flask clamps for platforms

For a list of clamps that are available for the matching dedicated platform, (see Tab. on p. 71).



All may be used on the universal platform.

Tab. 10-4: Flask clamps

Clamp size	Part number
10 mL Erlenmeyer flask	ACE-10S
25 mL Erlenmeyer flask	M1190-9004
50 mL Erlenmeyer flask	M1190-9000
125 mL Erlenmeyer flask	M1190-9001
250 mL Erlenmeyer flask	M1190-9002
500 mL Erlenmeyer flask	M1190-9003
1 L Erlenmeyer flask	ACE-1000S
2 L Erlenmeyer flask	ACE-20002
2.8 L Fernbach flask	ACFE-2800S
4 L Erlenmeyer flask	ACE-4000S
5 L Erlenmeyer flask	ACE-5000S
6 L Erlenmeyer flask	ACE-6000S

Eppendorf flask clamps come complete with mounting screws. Additional screws are available separately in packs of 25.

Ordering information

New Brunswick Innova® 43/43R Shaker
English (EN)

10.2.3 Test tube racks

For a list of available accessories, accessory capacity and corresponding part numbers, (see Tab. on p. 72).

Tab. 10-5: Accessories

Accessory description		New Brunswick part number	Platform capacity
Adjustable angle test tube rack for tubes 8 – 11 mm diameter	80 tube capacity	M1289-0100	7
	60 tube capacity	M1289-0010	9
	48 tube capacity	M1289-0001	9
Adjustable angle test tube rack for tubes 12 – 15 mm diameter	60 tube capacity	M1289-0200	7
	44 tube capacity	M1289-0020	9
	34 tube capacity	M1289-0002	9
Adjustable angle test tube rack for tubes 15 – 18 mm diameter	42 tube capacity	M1289-0300	7
	31 tube capacity	M1289-0030	9
	24 tube capacity	M1289-0003	9
Adjustable angle test tube rack for tubes 18 – 21 mm diameter	30 tube capacity	M1289-0400	7
	23 tube capacity	M1289-0040	9
	18 tube capacity	M1289-0004	9
Adjustable angle test tube rack for tubes 22 – 26 mm diameter	22 tube capacity	M1289-0500	7
	16 tube capacity	M1289-0050	9
	13 tube capacity	M1289-0005	9
Adjustable angle test tube rack for tubes 26 – 30 mm diameter	20 tube capacity	M1289-0600	7
	16 tube capacity	M1289-0060	9
	12 tube capacity	M1289-0006	9
Microplate holder rack (stacked)	3 deep well or 9 standard	M1289-0700	16
Microplate holder rack 5 deep well or standard TTR-221 4 (single layer)	5 deep well or standard	TTR-221	4
Angled test tube rack holder for user-supplied test tube racks that are 10 – 13 mm (4 – 5 in) wide and up to 38 mm (15 in) long.		TTR-210	4
Angled test tube rack spacer bar for use with TTR-210 to accommodate test tubes racks that are less than 13 mm (5 in) wide.		TTR-215	N/A



Universal platform is required for angled test tube rack holder and angled test tube rack spacer bar.

10.2.4 Optional gas manifold kit

Tab. 10-6: Factory-installed gas manifold kit

Description	New Brunswick part number
Gas manifold kit	M1320-0500

10.2.5 Optional photosynthetic grow lamps

Tab. 10-7: Factory-installed photosynthetic grow lamps

Description	New Brunswick part number
Photosynthetic growth lamp assembly	M1320-0300

10.2.6 Optional germicidal lamp

Tab. 10-8: Factory-installed germicidal lamp

Description	New Brunswick part number
UV germicidal lamp assembly	M1320-0400

10.2.7 Optional humidity monitor

Tab. 10-9: Factory-installed humidity monitor

Description	New Brunswick part number
Humidity monitor (for use with spill pan as water reservoir)	M1320-0600

10.2.8 Optional utility basket

Tab. 10-10: Utility basket

Description	New Brunswick part number
Utility basket	M1320-0700

10.2.9 Optional remote alarm

Tab. 10-11: Factory-installed remote alarm

Description	New Brunswick part number
Remote alarm	M1320-8029

Ordering information

New Brunswick Innova® 43/43R Shaker
English (EN)

11 Transport, storage and disposal

11.1 Disposal

In case the product is to be disposed of, the relevant legal regulations are to be observed.

Information on the disposal of electrical and electronic devices in the European Community:

Within the European Community, the disposal of electrical devices is regulated by national regulations based on EU Directive 2002/96/EC pertaining to waste electrical and electronic equipment (WEEE).

According to these regulations, any devices supplied after August 13, 2005, in the business-to-business sphere, to which this product is assigned, may no longer be disposed of in municipal or domestic waste. To document this, they have been marked with the following identification:



Because disposal regulations may differ from one country to another within the EU, please contact your supplier if necessary.

In Germany, this is mandatory from March 23, 2006. From this date, the manufacturer has to offer a suitable method of return for all devices supplied after August 13, 2005. For all devices supplied before August 13, 2005, the last user is responsible for the correct disposal.

Transport, storage and disposal

New Brunswick Innova® 43/43R Shaker
English (EN)

12 Declaration of conformity

The Innova 43/43R Shaker has been tested to ETL standards, to comply with UL and CAN/CSA electrical safety standards.

As attested in the CE Declaration of Conformity, the Innova 43/43R Shaker also conforms to the appropriate CE standards.

Declaration of conformity

New Brunswick Innova® 43/43R Shaker
English (EN)



New Brunswick
an eppendorf company



DECLARATION OF CONFORMITY

New Brunswick Scientific hereby declares that the product(s) listed below conform to the European Union directive and standards identified in this declaration.

Product(s)

Innova 43/43R

EU Directive(s)

Low Voltage (73/23/EEC/93/68/EEC)
Electromagnetic Compatibility (89/336/EEC/93/68/EEC)
CE Marking Directive (93/68/EEC)

Standard(s)

EN61010-1	EN61000-4-2
EN61010-2-010	EN61000-4-3
EN61010-2-081	EN61000-4-4
EN55011 (CLASS B)	EN61000-4-5
EN61000-3-2	EN61000-4-6
EN61000-3-3	EN61000-4-11

The conformity assessment procedures were performed at the following:

- Intertek testing services, 41 Plymouth Street, Fairfield, NJ 07004

The technical documentation relevant to the above equipment will be held at:

New Brunswick Scientific
175 Freshwater Blvd
Enfield, CT 06082 U.S.A
Tel. (860) 253-3400
Fax. (860) 741-0859

Henry Couture
Director of QA RA

Date

Index

A

Accessories.....11, 69
 Alarms11, 11
 Ambient conditions66
 ASCII52
 ATEX Guideline19

B

Baud rate41

C

Calibrate screen.....41
 Calibrating temperature offset44
 Changing screens36
 Changing the day42
 Changing the time43
 Clamp
 Double girdle clamp.....28
 Clamp installation.....27
 Clamp screws27
 Cleaning63
 COM parameters51
 Comm screen.....40
 Command codes.....56
 Command format.....52
 Commanding set speed.....52
 Creating a program46

D

Danger level7
 CAUTION8
 DANGER.....8
 NOTICE8
 WARNING8

Dimensions 66
 Display icons..... 34
 Display screen..... 36, 67
 Disposal 75

E

Edit a program 48
 Electrical connections..... 28
 Electrical requirements..... 24
 Environment 23

F

Features 10
 Flask capacities..... 70
 Flask clamp installation 27

G

Gas manifold 14
 Gas manifold kit..... 73
 Germicidal lamp..... 73
 Germicidal UV lamp..... 15
 Getting the time..... 55
 GRO lamps 73

H

Heater 13, 65
 Humidity monitor..... 16, 73
 HyperTerminal 51

I

Icons
 Alarm on 32
 Lid open..... 32, 32
 Lock on 32
 Program running 32
 Installing a platform..... 26

Index

New Brunswick Innova® 43/43R Shaker
English (EN)

Interior lights.....	13	R	
L		Refrigeration	10
LCD.....	67	Remote alarm.....	13, 73
Leveling the shaker	25	Remote programming.....	51
Lid.....	12	Report request commands.....	55
Location.....	24	Requesting measured values	52
M		Routine maintenance	63
Manual conventions	8	RS-232	12, 40
Memory		RS-232 mode	41
Non-volatile memory	49	RTD	61
Moving the shaker.....	25	S	
N		Safety	11
Narrow doorway.....	25	Screen descriptions	34
O		Screen names.....	34
Operating controls.....	31	Screen operation.....	36
Operation modes	10	Sending commands	51
Orbit	10	Service	13
P		Set commands	53
Packing list	23	Setpoints	
Parameters	37	Changing setpoints.....	38
Parameter meanings	33	Viewing setpoints	37
Parameter names	33	Setting temperature offset.....	44
Photosynthetic grow lamps.....	73	Setting the time	55
Photosynthetic growth lamps.....	15	Setup screen	39
Platforms	11	Shaking speed.....	65
Power interruption	49	Space requirements.....	24
Power supply.....	66	Spill pan/water reservoir.....	12
Powering on shaker.....	35	Symbols used.....	8
Program control commands.....	53	T	
Program timer	48	Temperature control	10
Programming from PC	51	Timed run	48
		Timer	
		Programming the timer	49

U

Unpacking23
User requirement19
Using this manual.....7
Utility basket73

W

Water reservoir.....12

Index

New Brunswick Innova® 43/43R Shaker
English (EN)

Evaluate Your Manual

Give us your feedback.
www.eppendorf.com/manualfeedback