

A Kawasaki robot for every application

Kawasaki Robot Lineup Overview



EMEA Headquarter, Sales and Service

Kawasaki Robotics GmbH
<http://robotics.kawasaki.com>
Im Taubental 32, 41468 Neuss, Germany
Phone: +49-2131-3426-0 Fax: +49-2131-3426-22

Locale Office

Kawasaki Robotics (UK) Ltd.
<http://robotics.kawasaki.com>
Unit 4 Easter Court, Europa Boulevard, Westbrook Warrington
Cheshire, WA5 7ZB, United Kingdom
Phone: +44-1925-71-3000 Fax: +44-1925-71-3001

Kawasaki Heavy Industries Russia LLC (KHI- Moscow)

<http://robotics.kawasaki.com>
Office 1206, entrance 3, 12 Krasnopresnenskaya emb.,
Moscow, Russian Federation 123610
Phone: +7-495-258-2115 Fax: +7-495-258-2116



Kawasaki Heavy Industries Middle East FZE (KHI-ME)

<http://robotics.kawasaki.com>
Dubai Airport Free Zone, Bldg. W6, Block-A,
Office No. 709, PO BOX 54878, Dubai UAE
Phone: +971-(0)4-214-6730 Fax: +971-(0)4-214-6729



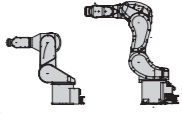
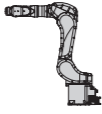
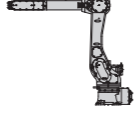
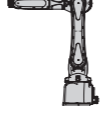
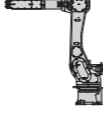
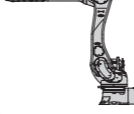

SMALL TO MEDIUM PAYLOAD ROBOTS – up to 80 kg R SERIES (including RA Series for ARC WELDING)

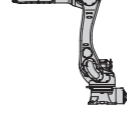
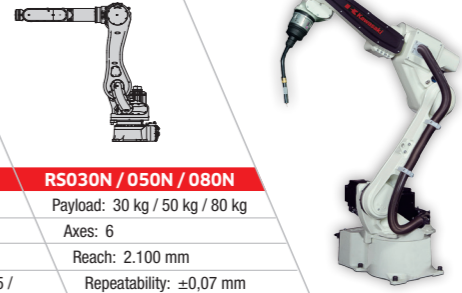
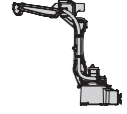
HOLLOW WRIST ARC WELDING ROBOT

										
RS003N / RS005N	RS005L / RA005L	RS006L / RA006L	RS007N / RS007L	RS010N / RA010N	RS010L / RA010L	RS015X	RS020N / RA020N	RS030N / O50N / O80N	BA006N / BA006L	
Payload: 3 kg / 5 kg	Payload: 5 kg	Payload: 6 kg	Payload: 7 kg	Payload: 10 kg	Payload: 10 kg	Payload: 15 kg	Payload: 20 kg	Payload: 30 kg / 50 kg / 80 kg	Payload: 6 kg	
Axes: 6	Axes: 6	Axes: 6	Axes: 6	Axes: 6	Axes: 6	Axes: 6	Axes: 6	Axes: 6	Axes: 6	
Reach: 620 mm / 705 mm	Reach: 903 mm	Reach: 1.650 mm	Reach: 730 / 930 mm	Reach: 1.450 mm	Reach: 1.925 mm	Reach: 3.150 mm	Reach: 1.725 mm	Reach: 2.100 mm	Reach: 1.455 / 2.036 mm	
Repeatability: ±0,05 / ±0,02 mm	Repeatability: ±0,03 mm	Repeatability: ±0,05 mm	Repeatability: ±0,03 mm	Repeatability: ±0,04 / ±0,06 mm	Repeatability: ±0,06 mm	Repeatability: ±0,15 mm	Repeatability: ±0,05 / ±0,06 mm	Repeatability: ±0,07 mm	Repeatability: ±0,06 / ±0,08 mm	



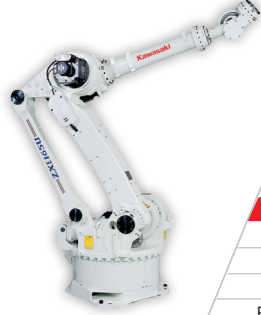
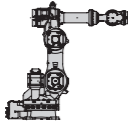
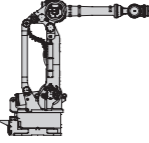
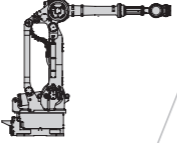
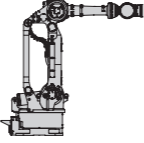
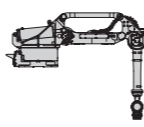
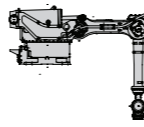

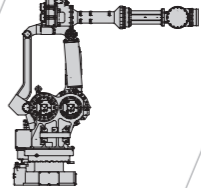
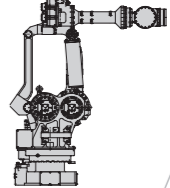
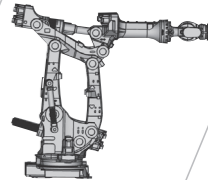

LARGE PAYLOAD ROBOTS – up to 300 kg Z SERIES

EXTRA LARGE PAYLOAD ROBOTS – up to 1.500 kg M SERIES

										
ZH100U	ZX130S / 165U / 200S	ZX130L	ZX300S	ZT130S / 165U / 200S	ZT165X	CX110L / 165L / 210L	MX350L / 420L	MX500N / 700N	MG10HL / MG15HL	
Payload: 100 kg	Payload: 130 kg / 165 kg / 200 kg	Payload: 130 kg	Payload: 300 kg	Payload: 130 kg / 165 kg / 200 kg	Payload: 165 kg	Payload: 110 / 165 / 210 kg	Payload: 350 kg / 420	Payload: 500 kg / 700 kg	Payload: 1.000 / 1.500 kg	
Axes: 6	Axes: 6	Axes: 6	Axes: 6	Axes: 6	Axes: 6	Axes: 6	Axes: 6	Axes: 6	Axes: 6	
Reach: 1.634 mm	Reach: 2.651 mm	Reach: 2.951 mm	Reach: 2.501 mm	Reach: 3.230 mm	Reach: 2.830 mm	Reach: 2.699 mm	Reach: 3.018 mm / 2778 mm	Reach: 2.540 mm	Reach: 4.005 mm	
Repeatability: ±0,3 mm	Repeatability: ±0,3 mm	Repeatability: ±0,3 mm	Repeatability: ±0,3 mm	Repeatability: ±0,3 mm	Repeatability: ±0,3 mm	Repeatability: ±0,2 mm	Repeatability: ±0,5 mm	Repeatability: ±0,5 mm	Repeatability: ±0,1 mm	

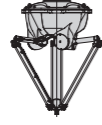
PICK & PLACE ROBOTS Y SERIES

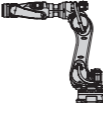
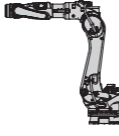
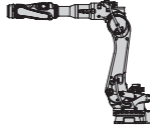
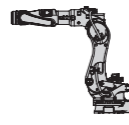
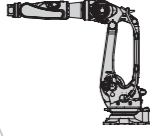
SPOT WELDING ROBOTS B SERIES







										
YF002N	YF003N		BX100S	BX100N	BX100L / 165L / 200L	BX130X / BX200X	BX165N	BX250L / 300L	BT200L	
Payload: 2 kg	Payload: 3 kg		Payload: 100 kg	Payload: 100 kg	Payload: 100 kg / 165 kg / 200 kg	Payload: 130 kg / 200 kg	Payload: 165 kg	Payload: 250 kg / 300 kg	Payload: 200 kg	
Axes: 4	Axes: 4 (Option 5)		Axes: 6	Axes: 6	Axes: 6	Axes: 6	Axes: 6	Axes: 6	Axes: 6	
Reach: 600 mm	Reach: 1.300 mm		Reach: 1.634 mm	Reach: 2.200 mm	Reach: 2.597 mm	Reach: 2.991 / 3.412 mm	Reach: 2.325 mm	Reach: 2.812 mm	Reach: 3.151 mm	
Repeatability: ±0,4 mm	Repeatability: ±0,1 mm		Repeatability: ±0,2 mm	Repeatability: ±0,2 mm	Repeatability: ±0,2 mm	Repeatability: ±0,2 / ±0,3 mm	Repeatability: ±0,2 mm	Repeatability: ±0,2 mm	Repeatability: ±0,2 mm	

PALLETIZING ROBOTS – up to 700 kg

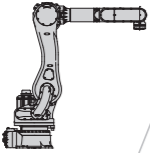
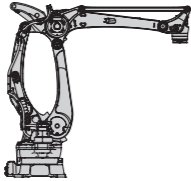
PAINTING ROBOTS – explosion-proof K SERIES

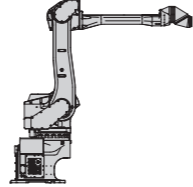
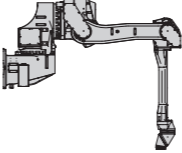
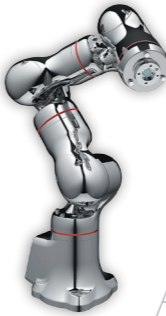
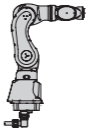
MEDICAL & PHARMACEUTICAL ROBOTS

collaborating DUAL-ARM-SCARA-ROBOT

											
RD080N	CP180L / 300L / 500L / 700L		KF121	KJ264 / KJ194		KJ314	MC004N / MC004V	MS005N		WD002N	
Payload: 80 kg	Payload: 180 kg / 300 kg / 500 kg / 700 kg		Payload: 5 kg	Payload: Wrist 15 kg, Arm 25 kg ???		Payload: Wrist 15 kg, Arm 25 kg	Payload: 4 kg	Payload: 5 kg		Payload: 2 kg each arm	
Axes: 4	Axes: 4		Axes: 6	Axes: 6		Axes: 7	Axes: 6	Axes: 7		Axes: 2 x 4	
Reach: 2.100 mm	Reach: 3.255 mm		Reach: 1.240 mm	Reach: 2.640 / 1.940 mm		Reach: 3.100 mm	Reach: 506 mm	Reach: 660 mm		Reach: 760 mm	
Repeatability: ±0,07 mm	Repeatability: ±0,5 mm		Repeatability: ±0,2 mm	Repeatability: ±0,5 mm FLOOR / SHELF / WALL		Repeatability: ±0,5 mm	Repeatability: ±0,05 mm	Repeatability: ±0,1 mm		Repeatability: ±0,05 mm	