

Resolvers

Housed and Frameless Feedback Devices

Housed Resolvers
Industrial Resolvers
Frameless Resolvers



Housed Brushless Resolvers p.3
Heavy-Duty Housed Resolvers p.4
Frameless Brushless Resolvers p.6
High-Accuracy Frameless Resolvers p. 7

HAROWE™ brand

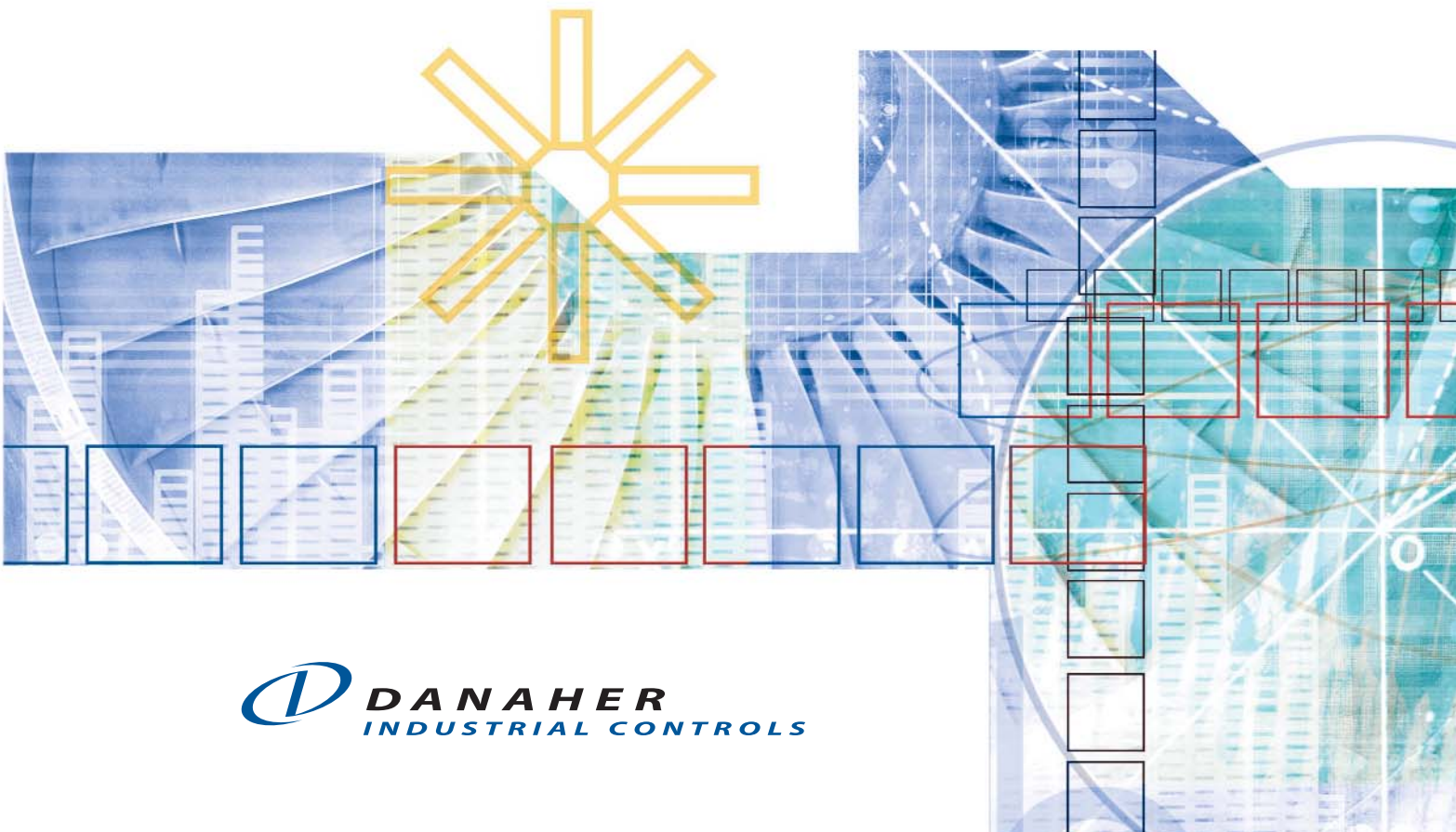



Harowe: The Most Trusted Brand for Durable Resolvers

Harowe has been trusted for rugged, noise resistant housed and frameless resolvers for over 50 years. Known for heavy-duty construction and non-stop performance in tough conditions, Harowe resolvers are the first choice for feedback in adverse operating conditions involving extreme temperature, high shock or vibration, and dirty environments. Harowe became a brand of Danaher Industrial Controls Group in 2004.

Harowe™ brand resolvers are part of a family of motion feedback controls from Danaher Industrial Controls Group (DICG). They include Harowe ultra-performance resolvers, Dynapar™ and Hengstler™ incremental and absolute encoders, and NorthStar™ heavy-duty encoders.

Zero Redesign...More Choices

Whichever feedback technology your customers want – incremental, absolute or resolver – you can give it to them, with no design changes and without changing vendors. Only DICG makes all three types of feedback devices in the exact same size and configuration. Simply drop the choice of device into your design and your job is done.



DYNAPAR™ brand Light Duty, Industrial Duty & High Performance Absolute and Incremental Encoders



For over 50 years, Dynapar continues to offer the world's broadest range of reputable brand-name encoder products to satisfy a full range of industrial factory, motor speed, linear and positioning applications.

NORTHSTAR™ brand Heavy Duty/Mill Duty Encoders & Pulse Tachs



For high performance and reliable speed feedback in extreme application environments for over 30 years.

HENGSTLER™ brand Absolute and Incremental Encoders



For counting and control applications, Hengstler is a respected European leader in absolute encoders and related industrial components such as counters/timers, industrial and temperature controllers, relays, and printers and cutters for over 160 years.

Heavy-Duty Housed Brushless Resolvers (Series 11, R11)

Harowe housed resolvers are available in a wide variety of electrical and mechanical configurations. Our brushless construction uses a rotary transformer to pass the reference signal to the rotor. This design eliminates the normal brush and slip ring sliding contact used in conventional resolvers. Since the brush and slip ring are life limiting components and can be a source of noise in harsh environments, the transformer coupled units enhance reliability and performance.

The industry-standard Size 11 resolver series has its own precision bearing system, making it ideal for coupling mounting. Alternately, the R11 shaft accepts pinions or pulleys for use in rack and pinion or cable measuring systems.

- Reliable in harsh environments
- Brushless construction—ideal mate for brushless servo motors
- Excellent angular accuracy & repeatability
- Maintenance free
- Shortest length in industry for easy packaging
- Temperature rating of 155°C for high temp applications
- Ideal for use in high shock applications

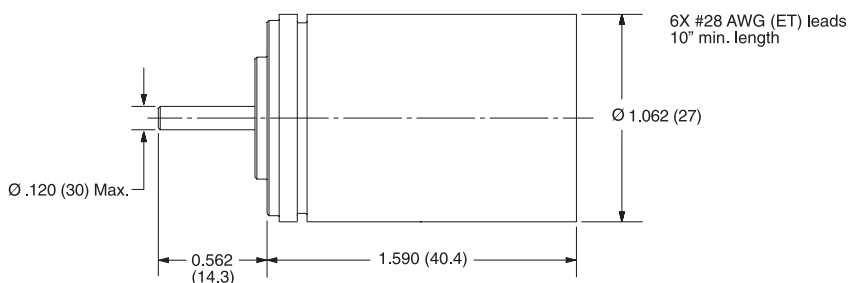

Family Model	Speed*	Primary Winding	Accuracy ± Arc-Min	Input Voltage (Vrms)	Frequency (Hz)	Maximum Input Current (mA)	Transformation Ratio (V out/ Vin) ± 10%	Phase Shift (degrees)	Total Null Voltage (mV)
11BRW-300-B	1	Stator	10	12.0	400	10.9	1.75	12	30
11BRW-300-F	1	Stator	7	12.0	2,500	3.1	0.50	-2	30
11BRW-300-M	1	Stator	7	10.0	5,000	8.3	0.50	-5	30
11BRCT-300-F	2	Stator	10	12.0	2,500	8.3	0.50	0	15
11BRCT-300-M	2	Stator	10	11.8	2,500	70.0	1.02	-1	30
11BRCT-300-T	4	Stator	5	12.0	2,500	6.0	0.53	-2	15
11BRCT-300-P	5	Stator	4	12.0	2,500	1.4	0.39	-7	15
11BRCX-300-A	1	Rotor	7	7.5	4,000	13.5	0.54	-2	20
11BRCX-300-B	1	Rotor	7	7.5	4,000	40.0	1.07	-2	15
11BRCX-300-C	1	Rotor	7	6.0	1,000	15	0.45	4	15
11BRCX-300-G	1	Rotor	7	26.0	400	40.0	0.45	12	30
11BRCX-300-J	1	Rotor	7	7.0	5,000	10.9	0.95	-6	15
11BRCX-300-N	1	Rotor	7	8.5	1,000	14.0	1.00	3	30
11BRCX-300-M	2	Rotor	7	7.0	5,000	10.9	0.95	-2	30
11BRCX-300-T	4	Rotor	7	7.0	5,000	11.0	0.84	7	20
11BRCX-300-P	5	Rotor	6	10.0	5,000	5.0	0.55	-3	20
R11-S01F-1A	1	Rotor	20	1.88	2,250	21.0	1.40	11	15
R11-S01F-1B	1	Rotor	20	6.00	2,000	12.0	0.454	8.5	15
R11-S01F-1A	1	Rotor	6	1.88	2,250	21.0	1.40	11	15

*Speeds are defined as follows: 1 = single speed; 2 = 2-speed; etc.

©2005 Danaher Industrial Controls Group. Printed in the U.S.A. The specifications in this publication are believed to be accurate and reliable. However, it is the responsibility of the product user to determine the suitability of Harowe products for a specific application. While defective products will be replaced without charge if promptly returned, no liability is assumed beyond such replacement.

Mill-Duty Housed Resolver (Series R25)

The Harowe R25 heavy duty brushless resolvers are designed for reliability in adverse operating conditions. Resolvers are the better choice over encoders for applications that involve very high temperature, vibration and shock and/or dirty environments. R25s will quickly recover their cost by eliminating frequent downtime caused by less robust transducers. You can trust the R25 to operate reliably 24 hours a day, 365 days a year in the worst industrial environments.

Unlike similar duplex-bearing packages, the R25 uses a front-and-rear bearing arrangement. This provides from two to three times the radial load bearing capacity and up to ten times the L10 life of a package with duplex bearings. The increase in load bearing capacity applies equally to static, dynamic, and shock loading.

- Rugged housing with IP-65 protection rating
- Ideal for high temperatures, high shock environments
- Standard MS-style connectors
- Flange- and servo-mount styles
- Shielded, spaced-support bearings provide up to 10X the life of duplex bearings
- Excellent noise immunity
- Standard +125°C continuous duty operating rating
- Corrosion resistant finishes
- Accuracy grades from +/- 2 to 20 arcmin
- Withstands shock to 200g, vibration to 40g



Elec. Kit	Speed (No. of Poles)	Xformer Ratio (V in/V out)	Input Voltage (Vrms)	Max. Curr. Input (mA)	Ref. Freq. (Hz)	Phase Shift (min)	Pri. Wndg.
1A	1 (2)	0.500	5.3	3	4000	-3	Stator
1B	1 (2)	0.500	4.0	25	5000	-6	Rotor
1C	1 (2)	0.470	4.25	55	7000	+4 ±3	Rotor
1D	1 (2)	0.500	7.0	25	2500	+6	Rotor
1E	1 (2)	0.950	7.0	12	5000	-3	Rotor
1F	1 (2)	1.000	2.0	10	5000	-8	Rotor
2A	2 (4)	0.250	8.0	20	4000	+5.5 ±3	Rotor
3A	3 (6)	0.470	4.25	55	7000	+5 ±3	Rotor

Inertia	0.0040 oz-in-sec ²
Friction	2 oz-in (5 oz-in w/shaft seal)
Shaft Load (max.)	40 lb (axial), 60 lb (radial)
Shaft	#416 S/S
Material	
Play (max.)	Radial: .0015 in @ 1 lb load; End: .005 in @ 5 lb load
Bearing	2 x 10 ⁸ revs at rated shaft loading
Life	

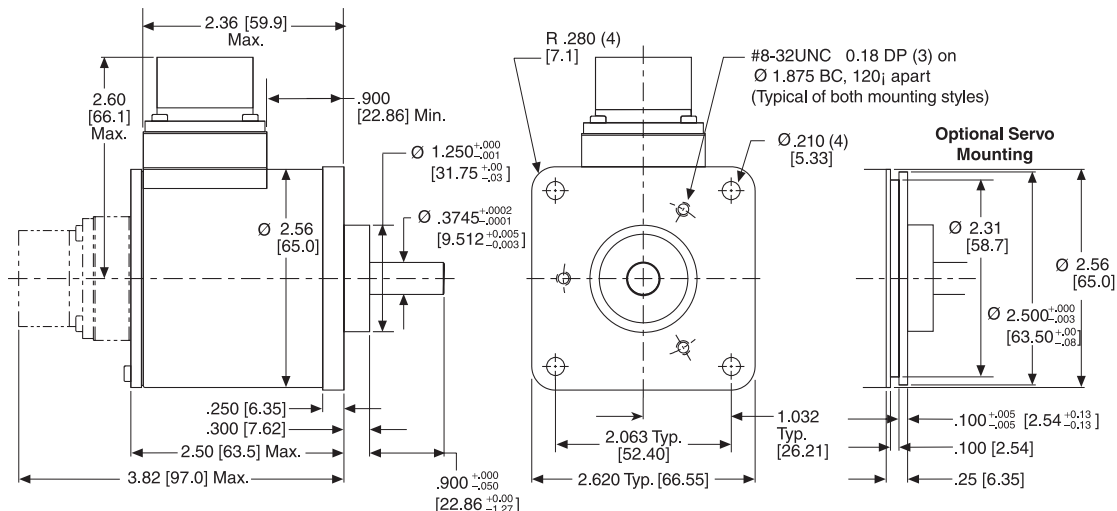

©2005 Danaher Industrial Controls Group. Printed in the U.S.A. The specifications in this publication are believed to be accurate and reliable. However, it is the responsibility of the product user to determine the suitability of Harowe products for a specific application. While defective products will be replaced without charge if promptly returned, no liability is assumed beyond such replacement.

Mill-Duty Housed Series R25 Model Numbering

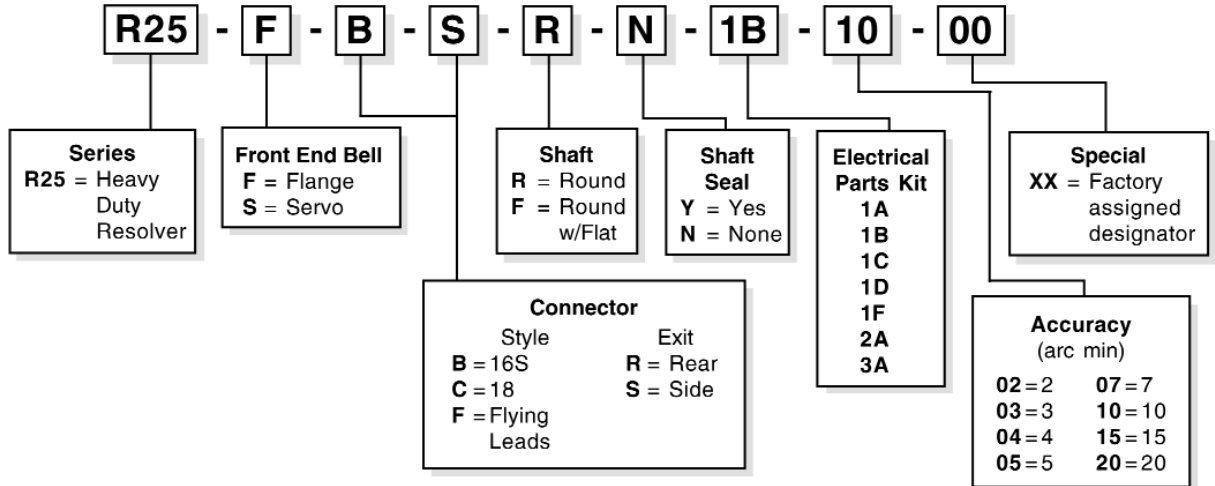

Connector and Cable Accessories

MS3106-style connectors and cable assemblies are offered to mate with Harowe heavy-duty R25 resolver packages.

Cables are low capacitance type (13 pF/ft) with individually shielded twisted pairs. They are available in one foot incremental lengths as standard, and custom lengths by special order.

Pin outs match the R25 and are consistent with industry standards for size 25 resolver packages.

MS3106F-16S-1S Connector

Pin	Signal	Cable Lead Color
A	R1 (Rotor Hi)	White
B	R2 (Rotor Lo)	Black w/White
C	S1 (Cos Hi)	Green
D	S3 (Cos Lo)	Black w/Green
E	S4 (Sin Lo)	Blue
F	S2 (Sin Hi)	Black w/Blue
G	Open	

MS3106F-18-1S Connector

Pin	Signal	Cable Lead Color
A	R1 (Rotor Hi)	White
H	R2 (Rotor Lo)	Black w/White
B	S1 (Cos Hi)	Green
I	S3 (Cos Lo)	Black w/Green
C	S4 (Sin Lo)	Blue
J	S2 (Sin Hi)	Black w/Blue
G	Open	

R25 Basic Schematic

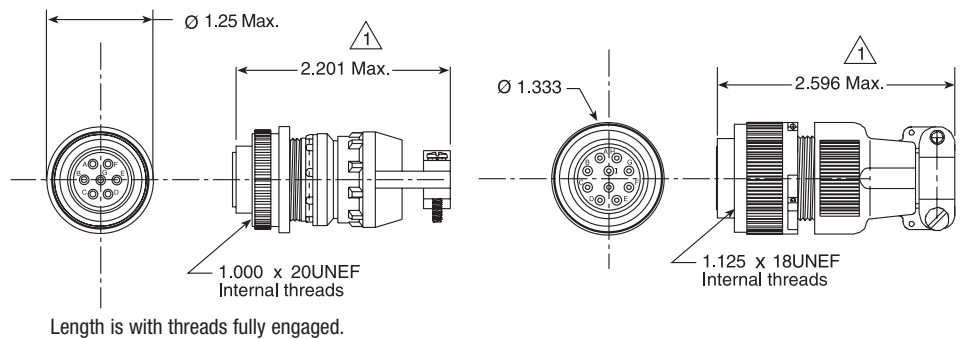
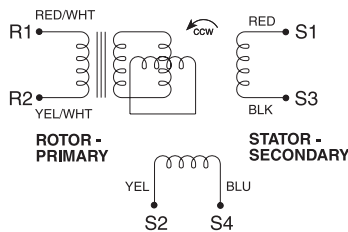

Use of Harowe mating connectors and low capacitance cable is recommended (or equivalent such as Belden 8163 cable with twisted-pairs for R1/R2, S1/S3 and S2/S4).

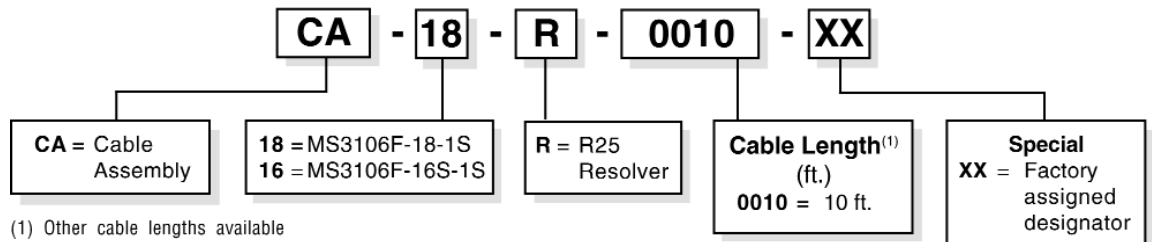

©2005 Danaher Industrial Controls Group. Printed in the U.S.A. The specifications in this publication are believed to be accurate and reliable. However, it is the responsibility of the product user to determine the suitability of Harowe products for a specific application. While defective products will be replaced without charge if promptly returned, no liability is assumed beyond such replacement.

Heavy-Duty Frameless Brushless Resolvers (Series 10, 15, 21, 31, 55)

Harowe brushless resolvers are the ideal position feedback transducer for brushless motors, robots and direct-drive motors in precision rotary platforms and similar servo applications.

Resolvers are the most versatile position transducers available for instrumenting rotary axes. They are rugged, reliable, able to operate at 155°C and impervious to most particulate and liquid process contaminants. In addition, resolvers provide absolute position information over one revolution (single speed types), and can be combined with an inexpensive integrated circuit to provide up to 16-bit digital word or emulated incremental encoder output, plus direction and analog velocity signals.

- Provide accurate, absolute position feedback
- Rugged and able to withstand high shock and vibration levels
- Highly resistant to EMI noise and radiation effects
- Impervious to most industrial contaminant and temperature extremes
- Brushless, lightweight devices that consume little power

Options

- Multiple speeds available (up to 32 on Size 55)
- Flux shielding technology
- Steel or aluminum housings
- Radiation hardened
- High temperature up to 200°C
- Flanged or Servo-groove mounting

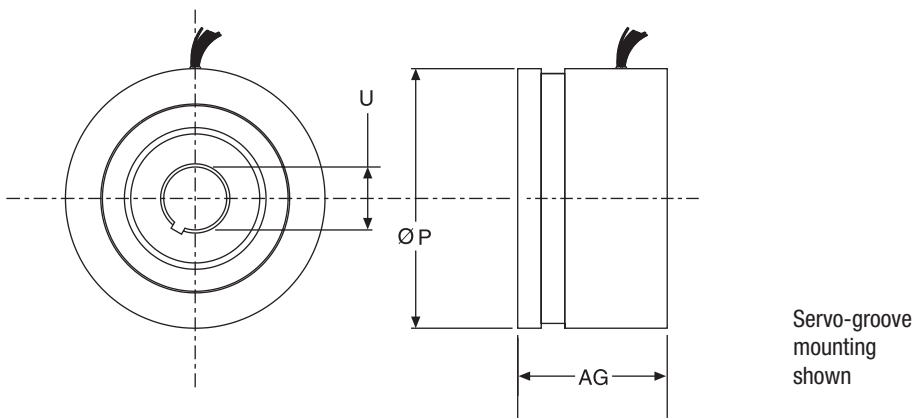

Model*	AG in (mm)	P in (mm)	U in (mm) Max
10BRCX	.65 (16.5)	1.05 (26.5)	.237 (6.0)
15BRCX	1.00 (25.4)	1.45 (36.8)	.472 (12.0)
21BRCX	1.25 (31.8)	2.06 (52.4)	.8007 (20.34)
31BRCX	1.25 (31.8)	3.05 (77.5)	1.5763 (40.04)
55BRCX	1.25 (31.8)	5.50 (139.7)	3.6515 (92.75)

*Available as transmitter and control transformer types.

Heavy-Duty High Accuracy 700 Series HaroMax Resolvers

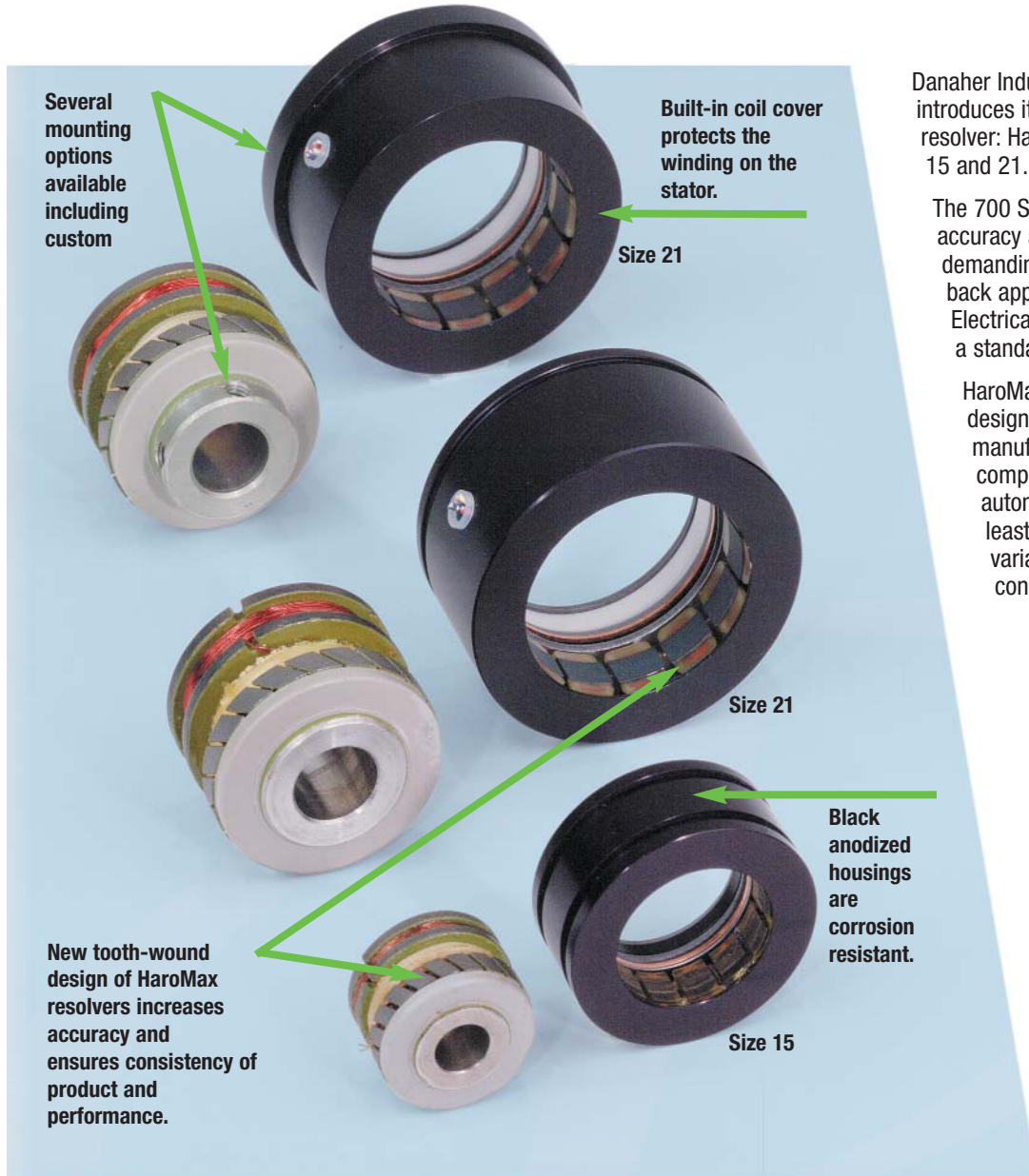

Danaher Industrial Controls Group introduces its newest frameless, brushless resolver: HaroMax Resolvers in sizes 15 and 21.

The 700 Series provides maximum accuracy and minimum error for those demanding position and velocity feedback applications such as robotics. Electrical error is 50% less than that of a standard resolver.

HaroMax Resolvers' new tooth-wound design incorporates windings that are manufactured and installed completely automatically. The automatic installation provides the least amount of part-to-part variation for the greatest consistency.

Danaher Industrial Controls Group is the leading North American manufacturer of frameless brushless resolver feedback products. For over fifty years, Harowe brand resolvers have been providing feedback solutions. Technical experience and design/manufacturing expertise are built into every Harowe resolver.

Worldwide Brands:

Anderson™
Dynapar™
Eagle Signal™
Harowe™
Hengstler™
Negele™
NorthStar™
Partlow™
PMA™
Veeder-Root™
West™

Danaher Industrial Controls Group was formed through the merger of eleven premier brands, each widely respected within their product categories. Now integrated into the Danaher Business System, these brands provide what you need to control the performance and reliability of your designs... controls for your world.

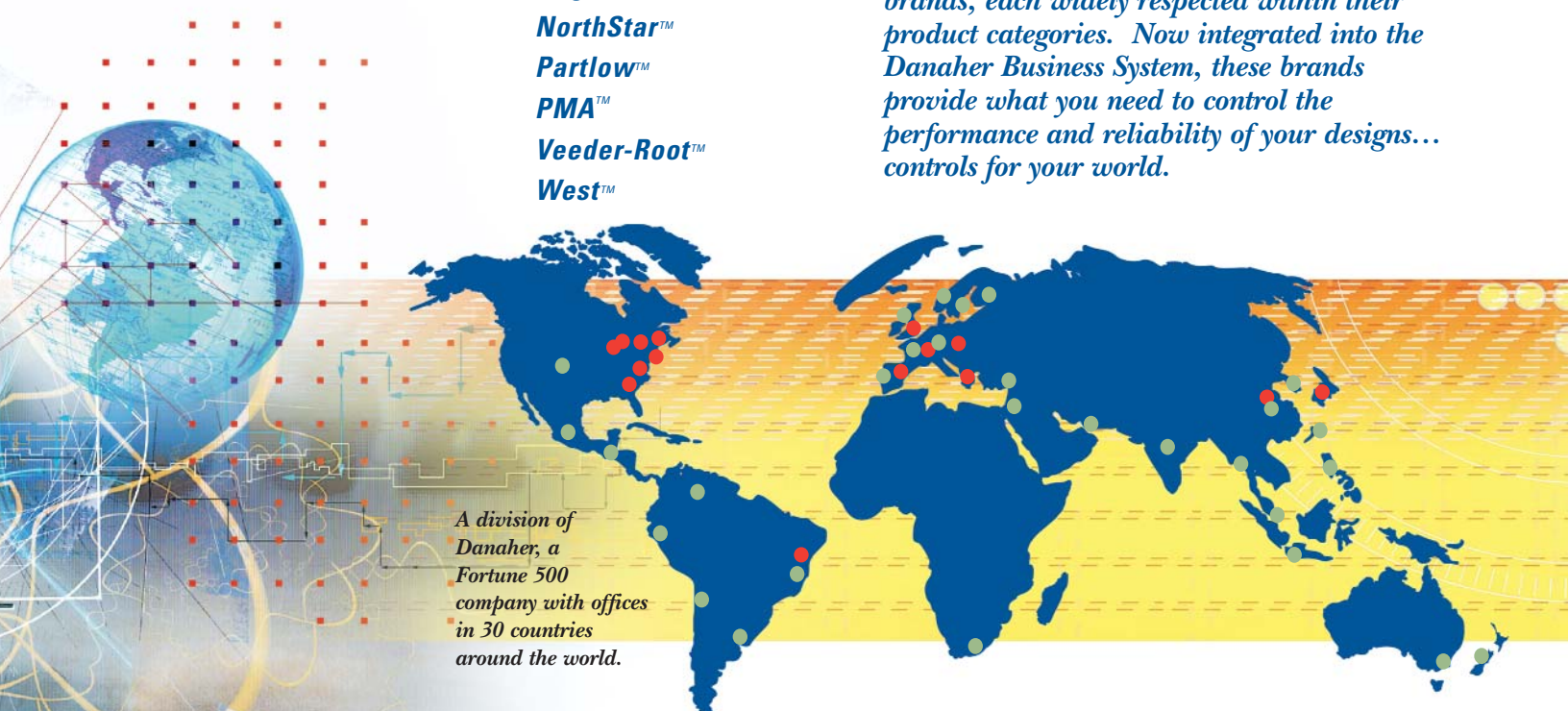

A division of Danaher, a Fortune 500 company with offices in 30 countries around the world.

More Available. With factories around the world, global sales and applications support, and an expansive network of distributors, we stay close to our customers – shortening lead times and fostering responsiveness. A three-day lead time is standard, with same-day shipments available on many products.

More Precise. After 230 combined years of experience in factory automation, we understand increasing demands for product performance. Our encoders and resolvers give you precise control of your designs, with resolution up to 22 bits.

More Durable. Experience with more than 25,000 customers has taught us to design for durability: ratings up to 220°C and mechanical shock and vibration specs that others envy.

More Customizable. JIT manufacturing enables us to immediately produce any of thousands of product variations. And we're happy to work with customers to customize resolvers to exact requirements.

For additional information or a full-line catalog, contact your DICG representative at +1 800.873.8731 or visit our web site at www.DanaherIndustrialControls.com.



Headquarters: 1675 Delany Road • Gurnee, IL 60031-1282 • USA
Phone: +1 847.662.2666 • Fax: +1 847.662.6633 • Email: dancon@dancon.com

Satellite Locations:

North America: North Carolina, South Carolina, Connecticut, Massachusetts, New York, Canada, British Virgin Islands

Europe: United Kingdom, Italy, France, Germany, Spain, Slovakia

Latin America: Brazil

Asia: China, Japan, Korea, Singapore

Anderson™ brand, Dynapar™ brand, Eagle Signal™ brand, Harowe™ brand, Hengstler™ brand, Negele™ brand, NorthStar™ brand, PMA™ brand, Partlow™ brand, Veeder-Root™ brand, and West™ brand, are trademarks or registered trademarks of Danaher Corporation and its subsidiaries.

+1 800.873.8731 • www.feedbackdevices.com