

NorthStarTM brand

Instruction Manual

WIND 56

Magneto-resistive Encoder for Pitch Control Unit Applications



**Patent
Pending**

CE
EN 61326



Customer Service:
Tel.: +1.800.873.8731
Fax: +1.847.662.4150
custserv@dynapar.com

Technical Support
Tel.: +1.800.234.8731
Fax: +1.847.782.5277
northstar.techsupport@dynapar.com

European Sales Representative
Hengstler GmbH
Uhlandstrasse 49, 78554 Aldingen - Germany
www.hengstler.de

Website: www.dynapar.com

***702820-0001* REV. B**

Table of Contents

Chapter/Paragraph/Illustration	Page
1 Introduction	4
1.0 Safety Summary	4
1.1 General	5
1.2 Description	5
Figure 1: WIND56 Exploded View w/ Spare Parts	5
1.3 Specifications.	6
2 Installation.	7
2.0 Inspection and Unpacking	7
2.1 Motor Facing and Shaft	7
Figure 2: Typical 4.5-Inch Diameter Type C-Face Mounting Surface	7
2.2 Encoder Frame Installation	8
Figure 3: Typical Motor Mounting	8
Figure 3a: Hub Alignment with Spacer	8
Figure 4: Pulse Wheel Orientation	9
2.3 Electrical Installation	10
2.4 Returning NorthStar brand Equipment to Dynapar	11
2.5 Ordering Information	12

Methods and apparatus disclosed and described herein have been developed solely on company funds of Dynapar. No government or other contractual support or relationship whatsoever has existed which in any way affects or mitigates proprietary rights of Dynapar in these developments. Methods and apparatus disclosed herein may be subject to U.S. Patents existing or applied for. Dynapar reserves the right to add, improve, modify, or withdraw functions, design modifications, or products at any time without notice. Dynapar shall not be liable for errors contained herein or for incidental or consequential damages in connection with furnishing, performance, or use of this material.

CHAPTER 1

INTRODUCTION

1.0 Safety Summary

High current, voltage, and rotating parts can cause serious or fatal injury. The use of electric machinery, like all other uses of concentrated power and rotating equipment, may be hazardous. Installing, operating, and maintaining electric machinery should be performed by qualified personnel, in accordance with applicable provisions of the National Electrical Code and sound local practices. Failure to comply with these precautions or with specific warnings elsewhere in this manual violates safety standards of design, manufacture, and intended use of the instrument. Dynapar assumes no liability for the customer's failure to comply with these requirements.

Rotating Machinery

Avoid contact with rotating parts. Avoid by-passing or rendering inoperative any safety guards or protection devices. Avoid extended exposure in close proximity to machinery with high noise levels. Use proper care and procedures in handling, lifting, installing, operating and maintaining the equipment.

Before Installation

Safe maintenance practices with qualified personnel is imperative. Before starting maintenance procedures, be positive that, (1) equipment connected to the shaft will not cause mechanical rotation, (2) main machine windings have been disconnected and secured from all electrical power sources, and (3) all accessory devices associates with the work area have been de-energized. If high potential insulation test is required, follow procedures and precautions outlined in NEMA standards MG-1.

Grounding

Improperly grounding the frame of the machine can cause serious or fatal injury to personnel. Grounding of the machine frame and structure should comply with the National Electrical Code and with sound local practices. Check wiring diagram before connecting power.

Do Not Operate In An Explosive Atmosphere

Do not operate the instrument in the presence of flammable gases or fumes. Operating any electrical instrument in such an environment constitutes a definite safety hazard.

Keep Away From Live Circuits

Operating personnel must not remove instrument covers. Component replacement and internal adjustments must be made by qualified maintenance personnel. Do not replace components with power cable connected. To avoid injuries, always disconnect power and discharge circuits before touching them.

Do Not Substitute Parts Or Modify Instrument

Do not install substitute parts or perform any unauthorized modification to the instrument. Introducing additional hazards is dangerous. Return the instrument to an authorized Dynapar representative for service and repair to ensure that safety features are maintained.

Dangerous Procedure Cautions

A CAUTION heading precedes potentially dangerous procedures throughout this manual. Instructions in the warnings must be followed.

1.1 General

These instructions do not claim to cover all details of variation in equipment or to provide for every possible contingency or hazard to be met in connection with installation, operation, and service. Should further information be desired or should particular problems arise which are not covered sufficiently for the purchaser's purposes, please contact Dynapar., or one of its designated representatives.

1.2 Description

The NorthStar WIND56 is a modular digital encoder. This magneto-resistive encoder sensor-based unit has been designed for fast, easy mounting onto a standard NEMA 56C motor face. The basic design philosophy is as follows: The encoder frame is mounted onto the C-face flange of a motor. This positions the sensor and contains the electronics. The magnetic pulse wheel on the motor shaft has magnetic pulses imprinted on its outside surface. As the motor spins, the passing magnetic pulses actuate the magneto-resistive sensor. The resulting electronic signals are processed into square wave signals by the internal electronics.

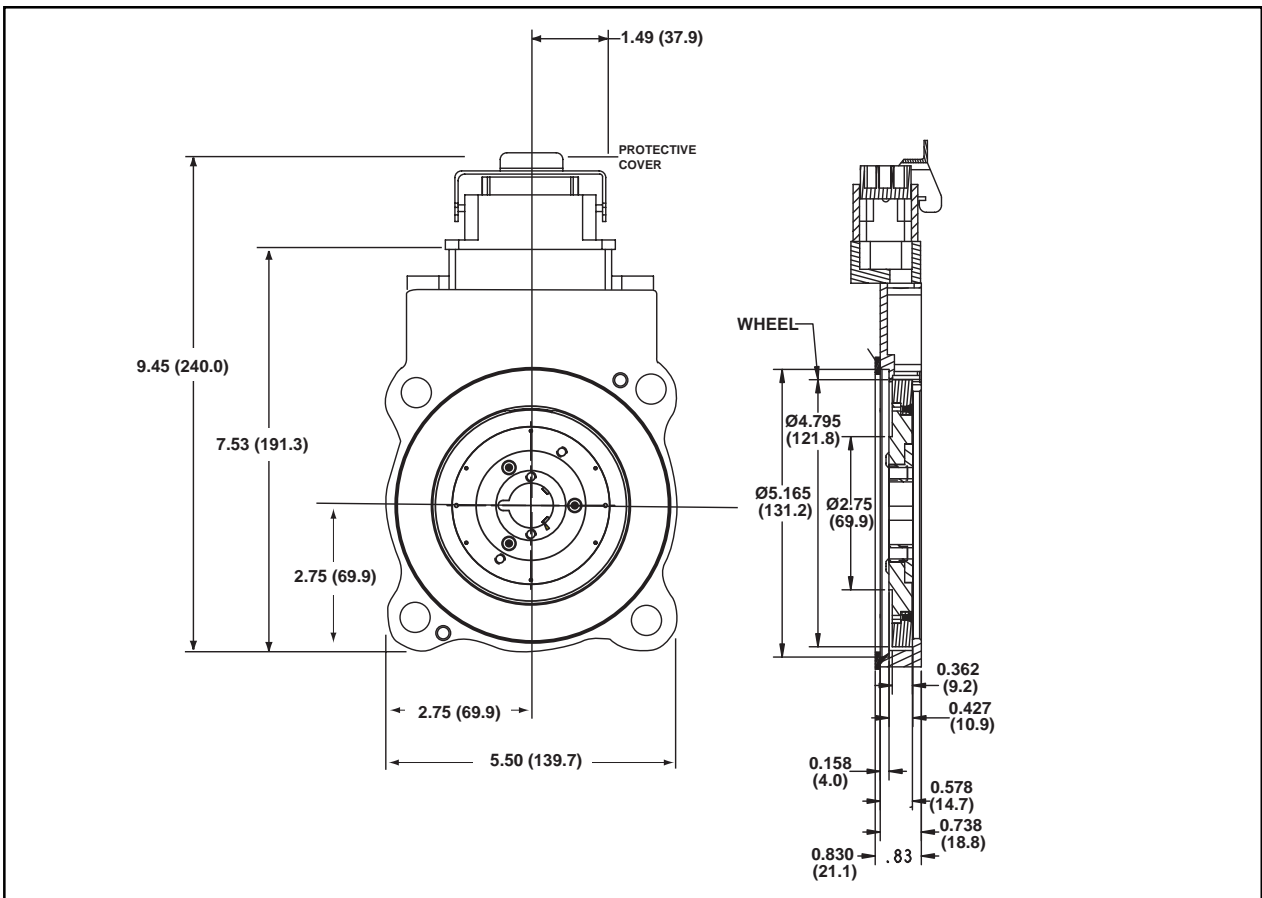

Figure 1: Dimensions - inch (metric)

1.3 Specifications

STANDARD OPERATING CHARACTERISTICS

Code: Incremental
Pulses per Revolution: 1024
Phasing Sense: A leads B for Counter-Clockwise rotation (CCW) viewing encoder-mounted end
Quadrature Phasing: $90^\circ \pm 22^\circ$
Symmetry: $180^\circ \pm 54^\circ$
Index: 180° to 2160°

ELECTRICAL

Input Voltage Requirement: 5-24V DC
Current Requirement: 50 mA
Output Signals:
 5-17 V Line Driver, 150mA
Frequency Response: 0 - 120kHz Data & Index
Electrical Immunity: 2kV ESD, Reverse Polarity, Short Circuit
Connector: 10 pin industrial duty latching, sealed NEMA 4 & 12, IP65 with gold pins

MECHANICAL

Shaft Speed: 5,000 RPM
Mounting Configuration: 4.5" 56C face mount for NEMA MG1 standards
Housing Material: Cast Aluminum
Acceleration Rate: 12,000 rpm/sec max
Shaft Length Required: 0.7" min
Allowable Shaft End-Play: $\pm 0.045"$
Wheel Bore: 1-1/8" with keyway
Weight: 2.8 lbs (1.3 kg);

ENVIRONMENTAL

Operating Temperature Range:
 Standard: -40°C to $+130^\circ\text{C}$
 See Table Below
Storage Temperature Range: -40°C to $+130^\circ\text{C}$
Humidity: to 98% RH (non-condensing)
Shock (Sensor Module): 1 meter drop test, 30 G's Min
Vibration: 18 G's @ 5-2000 Hz spectrum

ELECTRICAL CONNECTIONS

Signal	Connector Pin
Common	1
B	2
A	3
Z	4
No Connection	5
Vcc (5-15 VDC)	6
\bar{B}	7
\bar{A}	8
\bar{Z}	9
Shield	10

SAFE TEMPERATURE RANGE

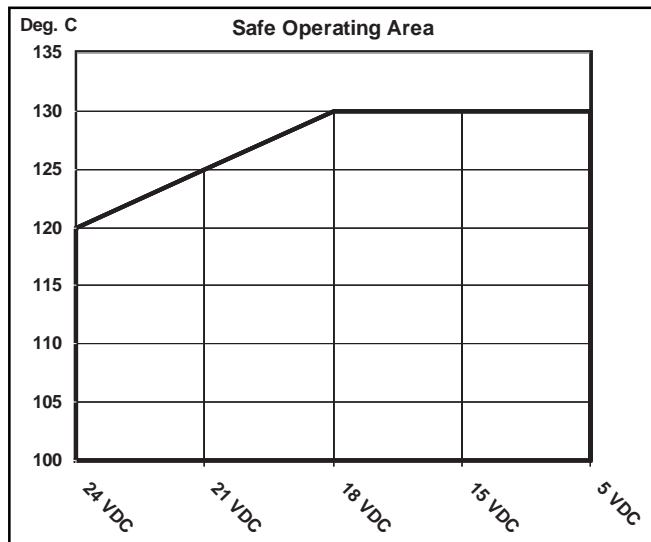

Specifications subject to change without notice
 Patent Pending

CHAPTER 2

INSTALLATION

2.0 Inspection and Unpacking

Inspect shipping container for external damage. All claims for damage (apparent or concealed) or partial loss of shipment must be made in writing to Dynapar within (5) days from receipt of goods. If damage or loss is apparent, please notify the shipping agent immediately.

Open shipping container and locate the packing list. The packing list is included to verify that all components, accessories, and manual were received. Please use the packing list to check off each item as the unit is unpacked. Inspect for damage. We recommend that the shipping container be retained for future shipping, storage, or return to factory purposes.

If any equipment was damaged in transit, be sure to file proper claims promptly with the carrier and insurance company. Please advise us of such filing. In case of parts shortages, advise us immediately. Dynapar cannot be responsible for any missing parts unless notified within 60 days of shipment.

2.1 Motor Facing and Shaft

To prepare the motor facing and shaft for installation, perform the following steps. See Figure 2.

1. Clean outer rim and surface of motor facing and shaft of paint, grease, dirt, and other debris where WIND56 unit contacts motor or accessory. Also ensure that mating surfaces have not been damaged and that unit will fit squarely on motor.
2. Apply a thin layer of corrosion preventative or oil to motor facing and shaft to aid assembly and provide some corrosion protection.

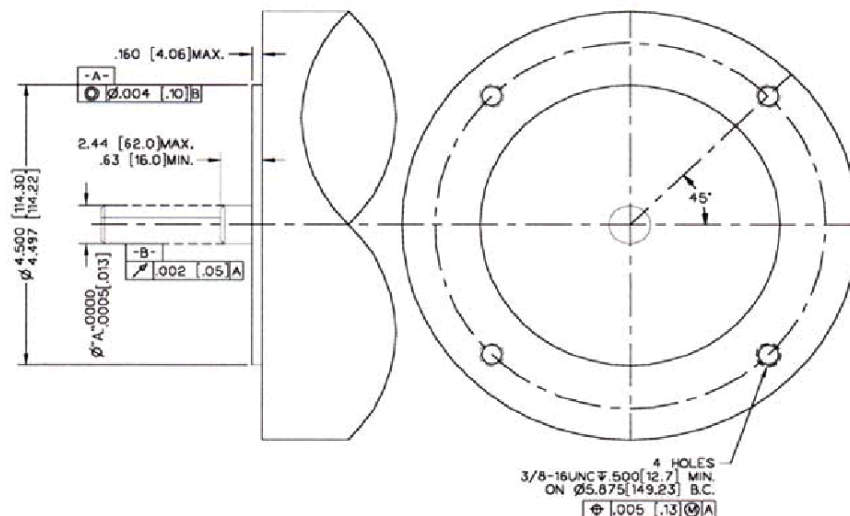

Figure 2: Typical 4.5-Inch Diameter Type 56 C-Face Mounting Surface

NOTE

Ensure there is no paint, burrs, protrusions, or deformations on the motor facing or shaft. If the enclosure does not fit squarely on the motor facing, the alignment between the sensor module and the magnetic pulse wheel may be degraded.

2.2 To install the encoder frame, perform the following steps:

NOTES:

1. The encoder and the wheel are a matched set and are not interchangeable. The serial numbers should be double checked to ensure proper assembly and performance. The serial number on the encoder is found on the encapsulation (example: 102). The serial number on the wheel is found on the front of the wheel (example: 102W).
2. The ENDURANCE 56 wheel consists of two parts:
 - A. The hub (secured to the shaft).
 - B. The pulse wheel (secured to the hub).

1) Install Hub: Position the hub so that the large flange faces the motor. Slide the hub on the motor shaft until it makes contact with the machined step. See Figure 3. If there is not a machined step, see Figure 3a to illustrate how to use the installation spacer to align the hub. The hub is now properly aligned. Apply Loctite 222 to the two 10-32 UNC set screws. Making sure the hub is firmly seated against the step or installation spacer, use a 3/32 inch hex wrench to tighten the screws to a nominal 25 in-lbs.

2) Install Encoder Housing: Orient the encoder frame so the 4.5 inch I.D. surface will fit over the 4.5 inch C flange (encapsulated side toward the motor). Do not bolt down.

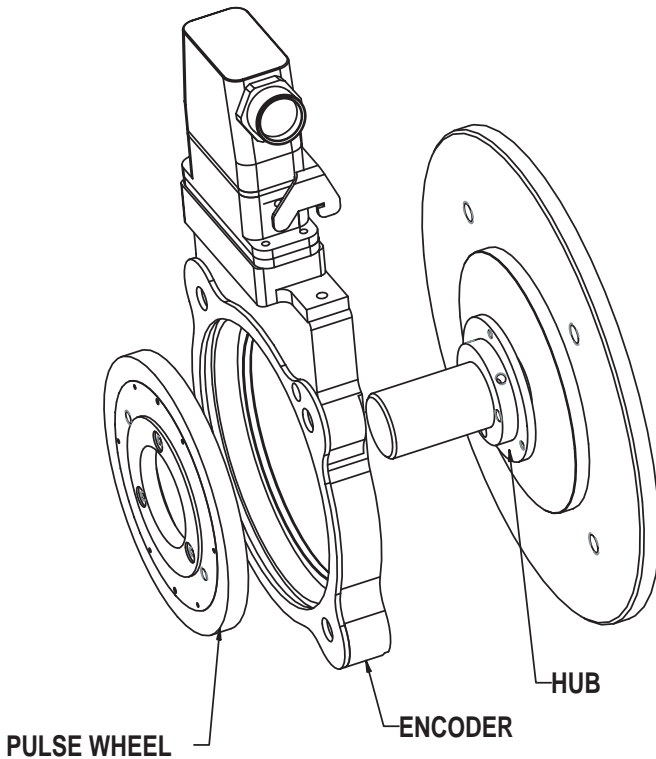

Figure 3: Typical Motor Mounting

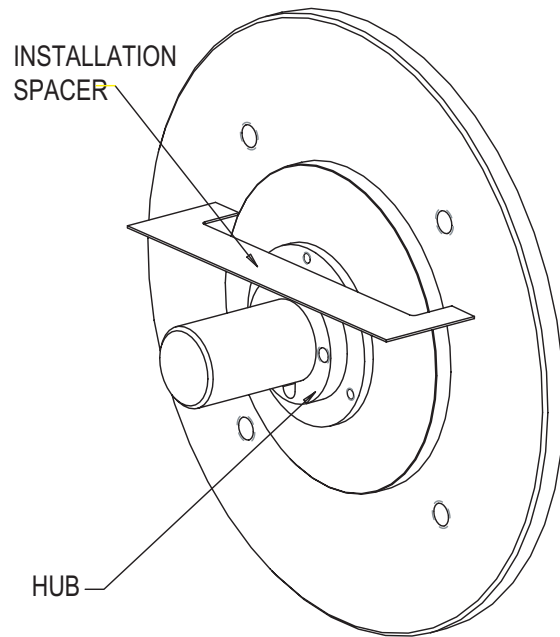

Figure 3a: Hub alignment with installation spacer

3) Install the Pulse Wheel: While holding the encoder frame, position the pulse wheel so the label This Side Out is visible. Slide it onto the shaft until it makes contact with the hub. Rotate the pulse wheel on the hub so the three mounting holes are aligned. It may be helpful to use two 1/4-20 UNC screws lightly threaded into the pulse wheel to help position the pulse wheel. Apply Loctite 222 to the three 8-32 UNC button head screws. Use a 3/32 inch hex wrench to tighten the screws into the pulse wheel to a nominal 20 in-lbs. Remove the two 1/4-20 UNC screws from the pulse wheel.

4. Install Brake Plate and Encoder Housing Hardware: Place the brake plate onto the motor shaft so the four counter bore holes align with the holes in the encoder frame. Insert the four 3/8-16 UNC screws through the brake plate and encoder frame and into the motor frame. Use a 5/16 inch hex wrench to tighten a nominal 25 in-lbs.

NOTE

Be sure "This Side Out" is visible on the face of the pulse wheel after installation

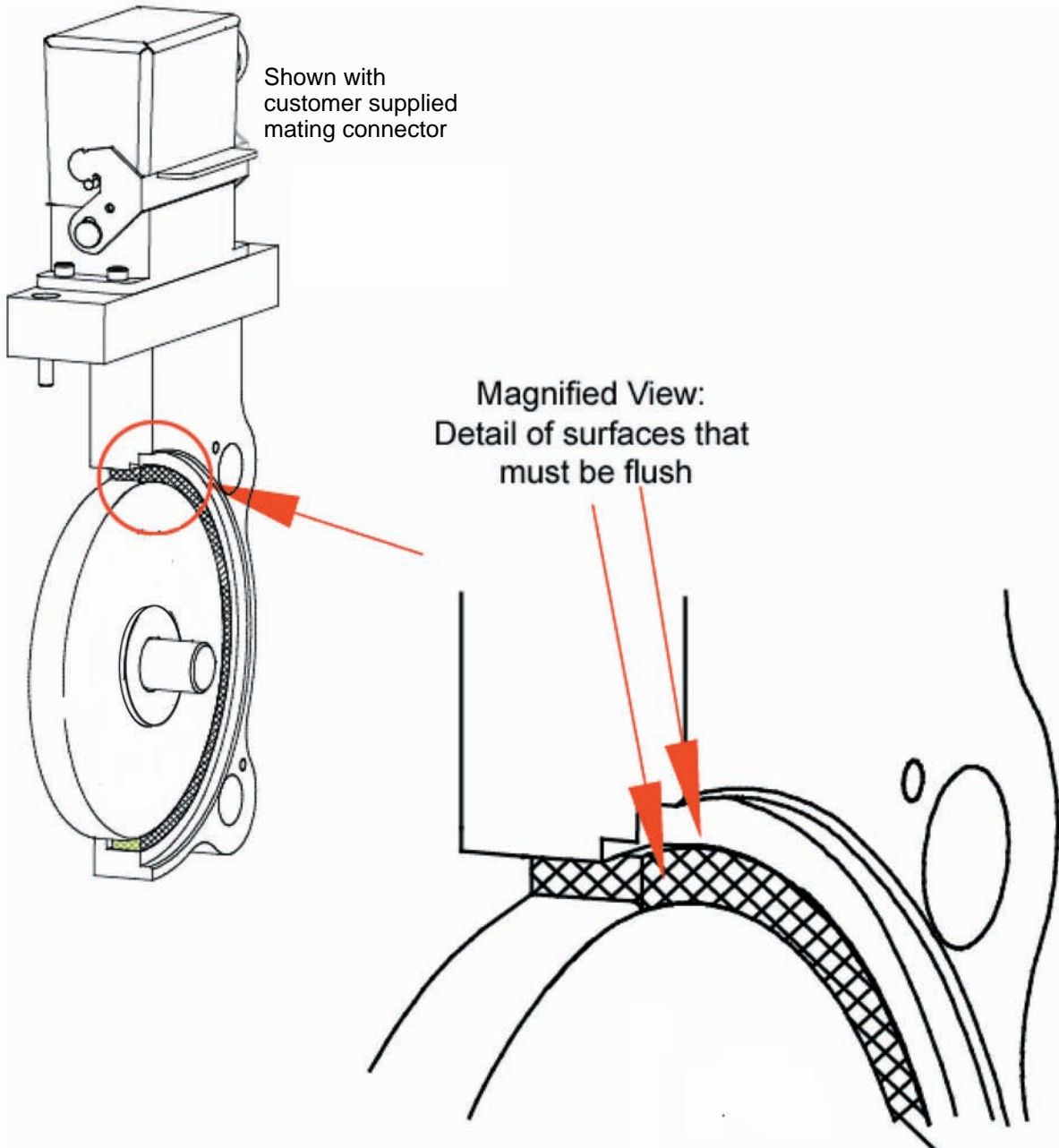

Figure 4: Pulse Wheel Orientation

2.3 Electrical Installation

Electrical connections are made to the sensor module through a standard 1/2 inch NPT liquid tight flexible conduit. The nipple length may be changed to extend the outlet box if desired. Interconnection cable recommendations are as follows: stranded copper, 22 through 16 gage, braided or foil with drain wire shielding 0.05 µF maximum total mutual or direct capacitance, outer sheath insulated. Shrink tubing may be placed over any wires without insulation. For lengths over 100 feet, use 18 gage or larger, to a maximum of 1000 feet. If shielded twisted pair wire is used, do not cross channels. Keep each pair of complementary channel outputs together in a single twisted pair (e.g., A and A complement).

Grounding: For applications with high ground potential differences, DO NOT ground the encoder through both machine and controls end. Connect the shield at the controls end only. **NOTE: If the shield is connected at both ends, grounding problems that degrade system performance can result.**

CE Grounding Measures – For best EMC immunity the cable screen must be grounded on both encoder and controls end. For cable lengths longer than 30m or outdoor applications, additional measures must be implemented to comply with CE requirements. Connection of the encoder to DC power supply network is prohibited if CE compliance is required. CE-compliant products are tested to EN61326-1 EMC.

In all cases, system CE compliance is ultimately the responsibility of the manufacturer integrating the encoder.

CAUTION!

Reversing power and common will not damage the unit. However, applying power to any of the sensor outputs may cause damage.

Table 1. Signal Coding Table

Signal	Connector Pin
Common	1
B	2
A	3
Z *	4
No Connection	5
Vcc (5-15 VDC)	6
/B	7
/A	8
/Z *	9
Shield	10

NOTE

The shield in the sensor module is isolated from the frame of the encoder for maximum noise immunity. The shield wire or pin should be connected to the shield of the cable and that of the drive or other receiving device.

2.4 Returning Equipment to Dynapar

If it is necessary to return the unit for repair or replacement, a Return Material Authorization (RMA) number must be obtained from a factory representative before returning the equipment to our service department. When returning an instrument for service, the following information must be provided before we can attempt any repair.

1. Instrument model and serial number
2. User's name, company, address, and phone number
3. Malfunction symptoms
4. Description of system
5. Returned Goods Authorization number

Consult the factory for shipping instructions.

2.5 Ordering Information

<u>Model Number</u>	<u>Description</u>
W56-1024A	WIND 56 Motor Mount Ring for 4-1/2" C-face motors (56C).



Customer Service:
Tel.: +1.800.873.8731
Fax: +1.847.662.4150
custserv@dynapar.com

Technical Support
Tel.: +1.800.234.8731
Fax: +1.847.782.5277
northstar.techsupport@dynapar.com

European Sales Representative
Hengstler GmbH
Uhlandstrasse 49, 78554 Aldingen - Germany
www.hengstler.de

Website: www.dynapar.com