

Resolvers 101

With unlimited resolution, inherent noise protection, and no onboard processors, the resolver provides a robust, high-performance solution for a range of demanding applications.



DYNAPAR™

INDUSTRY WHITE PAPERS

written/edited by Michael Prentice, Harowe Resolver Product Manager, Dynapar Corp.

Resolvers 101: Understanding the Basics

With unlimited resolution, inherent noise protection, and no onboard processors, the resolver provides a robust, high-performance solution for a range of demanding applications.

A resolver is an analog electromagnetic transducer that can be used in a wide variety of position and velocity feedback applications ranging from semiconductor manufacturing to oil and gas drilling, from beverage packaging to radiation treatment. Because the resolver is an analog device and the electrical outputs are continuous through one complete mechanical revolution, the devices offer infinite theoretical resolution. With its simple transformer design and lack of any on board electronics, the resolver is much more rugged than almost any other type of feedback device, making it the natural choice for harsh environments involving temperature extremes, high shock and vibration, elevated radiation levels, and contaminants such as dirt, grease, and oil. Whether the application is in a steel mill, a jet engine, or a punch press, a resolver can do the job.

Basic principles

Sometimes known as an analog trigonometric function generator or a control transmitter, a resolver is a special type of rotary transformer that couples voltage from an input (primary) winding into two output (secondary) windings with a magnitude that varies as a function of angular position.

The device consists of a rotor attached to a shaft that moves with the load, and a stator that remains stationary. The rotor typically carries the primary winding. The stator then carries two secondary windings that are angularly offset with respect to one another by 90°; they're designated as the sine winding and the cosine winding (see figure 1). In both sets of windings, the packing density of the individual turns of wire that make up the winding varies sinusoidally.

The function of a resolver is to resolve a vector into its sine and cosine components. An AC voltage applied to the reference winding inductively couples to the sine and cosine windings, generating an output voltage with a magnitude that varies as the sine or cosine, respectively, of the angular position of the input shaft relative to some zero point. To understand how, we need a brief review of trigonometry and analytic geometry.

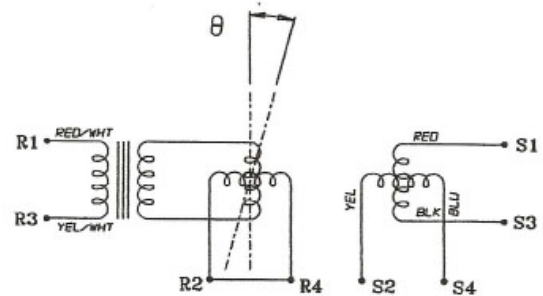

Figure 1: In a resolver, energy applied to the primary winding (the rotor coils, R1/R3) inductively couples to the secondary sine and cosine windings (the stator coils, S1/S3 and S2/S4) with a magnitude that varies as a function of the angular position θ of the rotor. Note that R2/R4 are shorted internally – this helps improve accuracy.

Consider a right triangle defined by the points (x_1, y_1) , (x_2, y_1) , and (x_2, y_2) ; see figure 2). For the angle θ , we define the side opposite θ as $y_2 - y_1$, the side adjacent to θ as $x_2 - x_1$, and the hypotenuse as R . We can then say:

$$\sin \theta = \frac{\text{opp}}{\text{hyp}} = \frac{(y_2 - y_1)}{R} \quad [1]$$

$$\cos \theta = \frac{\text{adj}}{\text{hyp}} = \frac{(x_2 - x_1)}{R} \quad [2]$$

DYNAPAR ♦ Experts In Rotary Feedback Solutions

1675 N. Delany Road ♦ Gurnee, IL 60031

P: 1.800.873.8731 ♦ F: 1.847.662.6633 ♦ custserv@dynapar.com ♦ www.dynapar.com

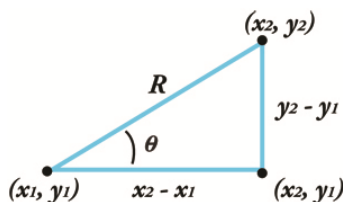

Figure 2: Using a right triangle, we can define $\sin \theta$ and $\cos \theta$.

We can define a circle with radius R in Cartesian coordinates as $R^2 = X^2 + Y^2$ (see figure 3). Based on the identities in equations 1 and 2, we can then express any point (X, Y) on a unit circle ($R = 1$) as:

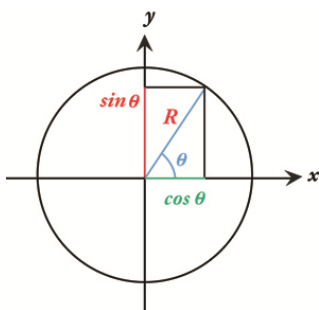

Figure 3: For a given angle θ , we can express the corresponding point on a unit circle ($R = 1$) in terms of $\sin \theta$ and $\cos \theta$.

From equation 1 and 2, we can state:

$$\tan \theta = \frac{\text{opp}}{\text{adj}} = \frac{(y_2 - y_1)}{(x_2 - x_1)} = \frac{\sin \theta}{\cos \theta} \quad [3]$$

which means that

$$\theta = \tan^{-1} \left[\frac{\sin \theta}{\cos \theta} \right] \quad [4]$$

In other words, to determine the angle with a resolver, we just need to take the arctan of the ratio of the two voltages supplied by the output windings of the resolver.

Resolver operation

We define electrical zero (EZ) as the position of the rotor with respect to the stator during excitation of the primary winding at which there is minimum voltage amplitude across the sine winding and the maximum voltage amplitude across the cosine winding (see figure 4). This ratiometric format provides an inherent noise-reduction feature for any injected noise whose magnitude is approximately equivalent on both windings, and it compensates for thermal swings.

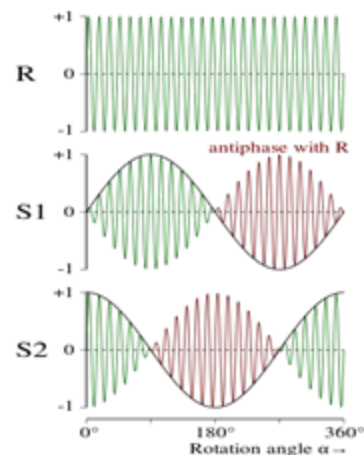

Figure 4: The ratiometric format of the resolver allows it to reject common-mode noise.

We define accuracy as the difference between the mechanical angular position indicated by electrical output signals and the true or actual mechanical angular position of the rotor with respect to the stator, usually given in units of arc minutes. This information can be used to plot an error curve that displays the error (arc minutes) versus angular position (degrees) over a full rotation of 360° (see figure 5).

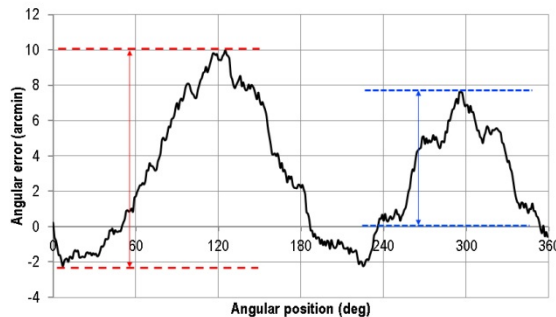

Figure 5: Error as a function of angular position over a full rotation can be expressed as peak-to-peak error (red) or maximum deviation (blue).

We specify accuracy in two main ways: as maximum deviation (+/-) or as peak-to-peak error spread (see table). Various design and manufacturing issues contribute to this error, including limitations in the distribution of the stator and rotor windings, inconsistencies of the winding placement in the lamination slots, number of slots in the rotor and stator laminations, mechanical imperfections that affect the radial uniformity, and material variations in the magnetic

characteristics of the material. The resolver error curve represents the sum of all the above issues.

Table 1: Difference between peak-to-peak accuracy and the +/- accuracy using data in figure 5

Degrees	Pk – Pk	+/-
0 - 360	12 arcmin	10 arcmin
60 – 150	8 arcmin	10 arcmin
180 – 270	10 arcmin	8 arcmin

Another important resolver characteristic is ripple or velocity error, which is simply the time-based derivative of the accuracy or electrical error curve. This may be of concern if the resolver is being used in a closed-loop feedback system for velocity control. Velocity control is important for applications like elevators or escalators, in which changes in velocity or speed would make users very nervous. It also plays a role in industrial processes like for injection molding machines, in which the flow of plastic material into the mold varies with velocity ripple – too great a degree of velocity ripple can negatively affect the surface finish of the molded part.

What to know before you call

1. What kind of accuracy do you need?
2. What are your operating conditions (temperature, contamination, vibration, etc.)?
3. What input voltage and frequency do your system present to the resolver?
4. What is your desired transformation ratio?
5. What is your system requirement for phase shift?

Building resolvers

Both the rotor and the stator are manufactured with multi-slot laminations and two sets of output windings (see figure 6). The windings are normally designed and distributed in the slotted lamination with either a constant-pitch, variable-turn pattern or a variable-pitch, variable-turn pattern. One set of windings in the rotor is normally shorted internally to improve the accuracy, as shown in figure 1. The actual choice of pattern depends on the application requirements such as temperature, speed, slot count, cost, accuracy, ripple, etc.



Figure 6: The stator coil of the resolver consists of the lamination (metal, left) wound with wire in a variable pattern (right). The white ring on the left is an end insulator.

In a typical variable-pitch design, one coil set spans eight teeth, one coil set spans six teeth, one coil set spans four teeth, and one coil set spans two teeth (see figure 7). A plot of the effective sum of the turns of each coil set on each tooth versus the tooth position in degrees creates a sine curve.

In a constant pitch design like the [21BRX HaroMax](#), the number and direction of turns on each tooth varies such that a plot of the actual number of turns on each tooth versus tooth position follows a sine curve.

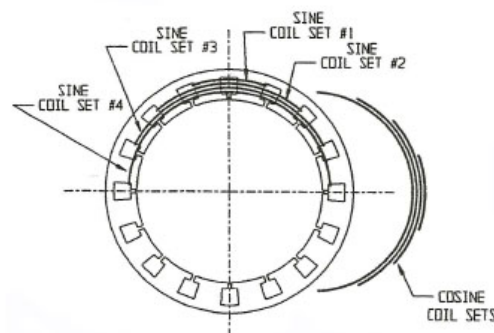

Figure 7: The windings of a variable-pitch resolver are formed by overlapping sets of coils

Resolvers are available in single- and multi-speed designs. Speed is something of a misnomer – in this context, it relates to the number of magnetic poles induced when the reference winding is energized, which in turn may affect the accuracy of the device. Variable-pitch windings can be used to make both single- and multi-speed resolvers; constant-pitch windings are normally used for single-speed resolvers only.

A single-speed resolver features two magnetic poles. The windings for a single-speed resolver are wound such that a plot of output voltage as a function of position for the device produces one complete cycle of a sine wave and one complete cycle of a cosine wave over each 360° mechanical rotation of the shaft. As a result, a single-speed (two-pole) resolver can provide absolute position feedback but may be affected more strongly by mechanical variations.

A multi-speed resolver is wound to produce multiple magnetic poles, which means that it generates multiple sine and cosine curves per mechanical revolution. A 3-speed resolver, for example, produces one sine/cosine wave cycle for each 120° of shaft rotation. As a result, it provides better accuracy; the higher the number of poles, the higher the accuracy. The Size 55 Frameless Resolver [55BRCX](#) from Dynapar, for example, includes 32 poles with an accuracy of 4 arcmin spread.

While accuracy is beneficial, there are trade-offs. Increasing the number of poles increases the complexity of the device and, hence, the cost. In addition, past a certain point, the ability to increase the number of speeds is limited by resolver diameter. Extremely demanding applications like MRI machines, for example, might use a resolver 4ft in diameter. Another approach is to combine a single-speed and a multi-speed resolver into a single package, which combines the absolute position of a single-speed resolver combined with the better accuracy of a multi-speed resolver to support fine and coarse positioning capabilities. The trade-off, again, is increased cost.

Using resolvers

The simplicity of the resolver design makes it reliable in many extreme applications. Some require operation in temperatures as high as 200°C, in high-radiation environments, or in situations with very high shock and vibration loadings. Let's take a look at a sampling of interesting examples:

Aerospace: A missile launcher for high-velocity armor-protected, self-propelled missiles with multi-engagement capability leverages [Size 21 Frameless Resolvers](#), [R25 Housed Resolvers](#), and DC servo motors for precision motion control.

Factory Automation: A single-axis lamination and notching press for the electrical equipment industry takes position information from a crankshaft driven by a 1200 RPM flywheel. Due to the high shock and vibration, an encoder feedback system failed in short order. The [R25 Housed Resolver](#) solved the problem easily and economically.

Food Processing: A sugar producer using vector drives on their sugar processing centrifuges chose the [R25](#)

[Housed Resolver](#) as a heavy-duty alternative to the more fragile encoder in this high-vibration environment.

Machine tools: A high-velocity profiler manufactures large airplane wing spars from solid aluminum. Two 100-hp horizontal spindles running at 20,000 RPM carve out 1600 in³ of metal per minute. The three-story- high, 107 ft. x 48 ft. machine uses a [Size 55 large bore Resolver](#) for the ever-critical tool changes, controlling tool position in the tool holder. The resolver delivers precision performance while exposed to oil mists, cleaning agents, metal fragments, and leakage from hydraulic hoses and the coolant systems.

Medical: Oncology machines use [Size 10 Frameless Resolvers](#) and [Size 11 Housed, radiation-hardened resolvers](#) for intensity-modulated radiation therapy (IMRT) that can "paint" the radiation dose onto a tumor with pinpoint precision. These machines need feedback devices that are radiation resistant to 10⁸ rad. The ability to spare healthy surrounding tissue by using this technique is so impressive that clinicians around the world are using it to treat nearly every type of solid tumor.

Printing Presses: A manufacturer of flexographic printing presses with solvent-based inks uses the [R11 Housed Resolver](#) for position feedback on the stepper motors that move the printing heads.

Semiconductor Manufacturing: Rotary tables used in wafer production require high-accuracy position control, silent operation, and absolute minimum vibration in a clean room environment. The solution was to replace the gearbox with a large torque motor monitored by a large-diameter [Size 55 Frameless Resolver](#).

Steel Mills: A steel mill uses vector drives and an [RF25 Housed Resolver](#) to handle large kettles of molten steel in an extremely hot area of the steel casting process.

In Summary

Feedback systems need to perform, but they also need to last. The resolver is a simple, elegant, robust solution that's surprisingly versatile. With unlimited resolution, inherent noise protection, and no onboard processors, the resolver provides a high-reliability, high-performance solution for a range of demanding applications. Got a tough problem? Find out what a resolver can do for you.

Dynapar offers the world's broadest range of encoders, resolvers and accessories for motion feedback control. For 50 years, the four brands of Dynapar have been providing innovative, customized system solutions for virtually any heavy-duty, industrial, servo, or light-duty application. Innovative products, designed your way, delivered when you need them—that's the Dynapar difference. Click [here](#) for more information.

DYNAPAR ♦ Experts In Rotary Feedback Solutions

1675 N. Delany Road ♦ Gurnee, IL 60031

P: 1.800.873.8731 ♦ F: 1.847.662.6633 ♦ custserv@dynapar.com ♦ www.dynapar.com