

Hydrofinity™

Sustainable
Fabric Care Technologies
from Xeros

XE20C01 20kg | 45lb

Commercial Laundry Machine

Significantly reducing water & chemical use, our unique laundry system helps you cut operational costs and improves the look, feel & longevity of linens.

Along with cutting-edge equipment, you'll receive a tailored maintenance package, which can include support, installation, consumables, training, and servicing.

We are your simple, stress-free, single point of contact.

Machines are metered & monitored by **XConnect**, our innovative web-based IoT laundry management solution that lets you oversee operations in real time. On desktop or smartphone, you can view the activity of each Hydrofinity machine, generating reports to track how much water & energy has been used, with estimated ROI results.

XOrbs™ - Powering Sustainable Laundry Systems

Instead of relying on hot water & harsh chemicals, our washers use innovative spheres called **XOrbs™**, alongside industry-approved chemicals.

XOrbs™ gently massage fabrics and absorb dirt and use up to 80% less water per load than conventional machines.

Our unique solution gets linens clean in one cycle, reducing the need for pre-treating and repeat washes - reducing staff labour time as well as water and energy consumption. Along with dirt & stains, **XOrbs™** soak up stray colours, reducing staining, streaking and dulling of textiles

XE20C01: Soft Mount Washer Extractor

With a soft mount design, the XE20C01 is enhanced with customised software controls. Familiar front-loading design and easy-to-use controls have been customised for use with our cutting-edge sustainable laundry & fabric care technology.

- * Full-colour 7" touch screen programmable controller
- * All electric valves
- * Large, easy-to-load drum and easy-to-clean lint filter

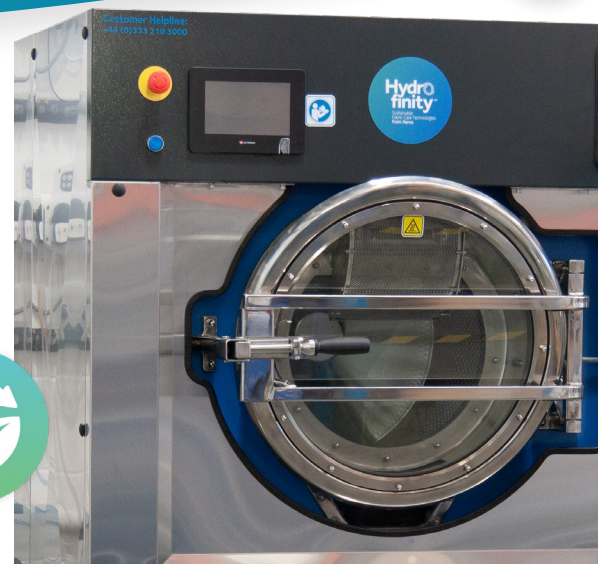

XE20C01 20kg | 45lb

Commercial Laundry Machine

Machine Capacity	20 kg (45 lb)
Cylinder Size	Ø810 mm x 520 mm (Ø31.9" x 20.5")
Cylinder Volume	272 L (9.6 cu ft)
Water Inlets (2):	3/4 BSPT
Water Inlet Pressure	2-3 Bar [3 Bar Max] (29-43.5 psi [43.5 psi Max])
Drain Pipe	57 mm (2.25") OD
High Extract	Up to 810 RPM
G-Force	Up to 294 g
Heating (Electric)	XE20C01-xxxE: 15 kW
Control	7" Touch Screen
Net Weight	1120 kg (2470 lb)
Dimensions (C x B x A)	1443 mm x 1161 mm x 1548 mm (56.8" x 45.7" x 60.9")
Drive Motor Size	3 kW
Drive System	Inverter / Variable Frequency Drive
Power	400 V (±10%) x 3ph x 50Hz (EU) 208-220 V x 3ph x 60Hz (US)
Wash Formulas	Up to 25
Rated Current (typical circuit breaker)	XE20C01-215H: 24 A (30 A breaker) XE20C01-215E: 60 A (75 A breaker) XE20C01-400E: 32 A (32 A breaker)
Door Diameter (Loading Aperture)	Ø470 mm (Ø18.5")
Recommended Centerline Height	960 – 1252 mm (37.8" – 49.3")
Noise Level	<85 dB (at workstation position)

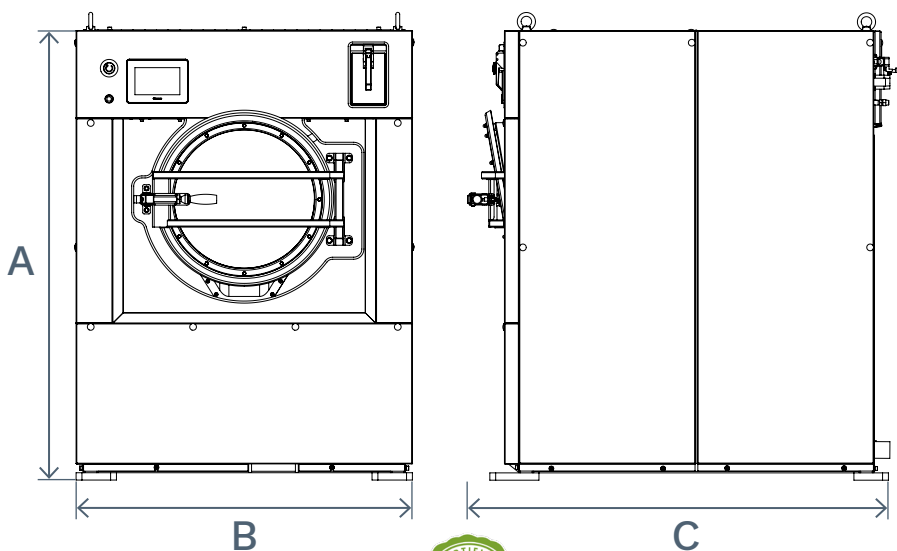

Hydrofinity EMEA

Evolution Unit 2 Whittle Way
Advanced Manufacturing Park
Rotherham, South Yorkshire
S60 5BL United Kingdom

t. +44 (0)114 269 9656

Hydrofinity USA

195 Dupont Drive
Providence, Rhode Island 02907

t. +1 (844) 207-1099

hydrofinity.com

