



**IMPORTANT FOR FUTURE REFERENCE**

Please complete this information and retain this manual for the life of the equipment:

Model #: \_\_\_\_\_

Serial #: \_\_\_\_\_

Date Purchased: \_\_\_\_\_

Installation and Operation Manual  
For Gas Fryer  
NO OPTION/STAND ALONE  
Covering Model  
VF35



ENGLISH

**TO THE PURCHASER, OWNER AND STORE MANAGER**  
Please review these warnings prior to posting them in a prominent location for reference

<b>TO THE PURCHASER</b>
Post in a prominent location the instructions to be followed in the event that an operator smells gas. Obtain this information from your local gas supplier.
<b>FOR YOUR PROTECTION</b>
DO NOT store or use gasoline or other flammable vapors and liquids in the vicinity of this or any other appliance. Do not spray aerosols in the vicinity of this appliance when it is in operation.
<b>WARNING</b>
Improper installation, operation, alteration, adjustments, service or maintenance can cause property damage, injury or death. Read the installation, operating and maintenance instructions thoroughly before installing, operation, servicing this appliance.

**WARNING**

Installation, maintenance and repairs should be performed by a Pitco Authorized Service and Parts (ASAP) company technician or other qualified personnel. Installation, maintenance or repairs by an unauthorized and unqualified personnel will void the warranty.

**WARNING**

Installation and all connections must be made according to local codes in force. In the absence of local codes in North America, the installation must conform with the National Fuel Gas Code, ANSI Z223.1/NFPA 54 or the Natural Gas and Propane Installation Code CSA B149.1 as applicable. In Australia, the appliance must be installed in compliance with AS/NZS 5601.

**WARNING**

During the warranty period if a customer elects to use a non-original part or modifies an original part purchased from Pitco and/or its Authorized Service and Parts (ASAP) companies, this warranty will be void. In addition, Pitco and its affiliates will not be liable for any claims, damages or expenses incurred by the customer which arises directly or indirectly, in whole or in part, due to the installation of any modified part and/or received from an unauthorized service center.

**WARNING**

Adequate means must be provided to LIMIT the movement of this appliance without depending on the gas or electrical cord connection. Single appliances equipped with legs must be stabilized by installing anchor straps. All appliances equipped with casters must be stabilized by installing restraining chains.

**WARNING**

DO NOT alter or remove structural material on the appliance to accommodate placement under a ventilation hood.

**WARNING**

If the appliance is equipped with a power cord and it is damaged, it must be replaced by a Pitco Authorized Service and Parts (ASAP) company technician or a similarly qualified person in order to avoid a hazard.

**WARNING**

The power supply must be disconnected before servicing, maintaining or cleaning this appliance.

**WARNING**

The appliance is NOT jet stream approved. DO NOT clean the appliance with a water jet.

**WARNING**

DO NOT attempt to move this appliance or transfer hot liquids from one container to another when the unit is at operating temperature or filled with hot liquids. Serious personal injury could result if skin comes in contact with the hot surfaces or liquids.

**WARNING**

DO NOT use an open flame to check for gas leaks!

**WARNING**

DO NOT sit or stand on this appliance. The appliance's front panel, tank, splash back, tank cover, work shelf, drain board is not a step. Serious injury could result from slipping, falling or contact with hot liquids.

**WARNING**

NEVER use the appliance as a step for cleaning or accessing the ventilation hood. Serious injury could result from slips, trips or from contacting hot liquids.

**WARNING**

The oil/shortening level should NOT fall below the minimum indicated level line at any time. The use of old shortening can be dangerous as it will have a reduced flash point and be more prone to surge boiling.

**WARNING**

Completely shut the appliance down when shortening/oil is being drained from the appliance. This will prevent the appliance from heating up during the draining and filling process. Serious injury can occur.

**WARNING**

This appliance is intended for indoor use only.

**WARNING**

DO NOT operate appliance unless all panels and access covers are attached correctly.

**WARNING**

It is recommended that this appliance be inspected by a qualified service technician for proper performance and operation on a yearly basis.

**WARNING**

There is an open flame inside this appliance. The unit may get hot enough to set nearby materials on fire. Keep the area around the appliance free from combustibles.

**WARNING**

DO NOT supply the appliance with a gas that is not indicated on the data plate. If you need to convert the appliance to another type of fuel, contact your dealer.

**WARNING**

If gas flow to appliance is interrupted, or pilots extinguish, wait 5 minutes before attempting to relight the pilot to allow any residual gas in appliance to dissipate.

**WARNING**

Ensure that the appliance can get enough air to keep the flame burning correctly. If the flame is starved for air, it can give off a dangerous carbon monoxide gas. Carbon monoxide is a clear odorless gas that can cause suffocation.

**WARNING**

Never add oil to the appliance when it is at operating temperature. Splashing hot oil can cause severe injuries.

**WARNING**

Never add water to hot oil. Violent boiling can occur causing severe injury.

**WARNING**

This appliance is intended for professional use only and should be operated by fully trained and qualified personnel.

**WARNING**

To avoid splashing of hot liquid when installed, this fryer must be restrained either by the manner of installation, or with adequate ties to prevent tipping.

**WARNING**

An appliance equipped with casters and a flexible gas line must be connected to the gas supply with a quick disconnect device. In North America, gas appliances equipped with casters must be installed with connectors that comply with the Standard for Connectors for Movable Gas Appliances, ANSI Z21.69.CSA 6.16 Latest Edition. This connection should include a quick disconnect device that complies with the Standard for Quick Disconnect Devices for Use With Gas Fuel ANSI Z221.41.CSA 6.9 Latest Edition. In Australia, an appliance equipped with casters and a flexible gas line must be connected to the gas supply with a quick disconnect device that complies with AS 4627. The hose must comply with AS/NZS 1869 and be class B or D and have a restraining cable. The restraining cable must not exceed 80% of the length of the flexible gas line.

## **NOTICE**

In the event of problems or questions about your order, contact the Pitco Frialator factory at (603) 225-6684.

In the event of problems or questions about your equipment, contact the Pitco Frialator Authorized Service and Parts representative (ASAP) covering your area, or contact Pitco at the numbers listed above.

### **MAILING ADDRESS**

Pitco Frialator  
P.O. Box 501  
Concord, NH 03302-0501

### **SHIPPING ADDRESS**

Pitco Frialator  
10 Ferry Street  
Concord, NH 03301

### **Standard Accessories**

- One tube rack
- One built-in flue deflector
- Two twin size baskets
- One drain extension
- One drain line clean out rod
- Removable basket hanger
- 9" legs adjustable

# Table of Contents

NOTICE .....	3
INSTALLATION .....	5
Checking And Unpacking Your New Appliance.....	5
Installation Clearances.....	5
Leveling The Fryer – Legs/Casters.....	6
Gas Connection.....	7
Fuel Types .....	7
Quick Disconnect Gas Connection .....	7
Fuel Supply Line Leak and Pressure Testing.....	7
Ventilation And Fire Safety Systems.....	8
Gas Line Requirements.....	8
Lighting Instructions.....	9
Initial Cleaning .....	9
Daily Cleaning.....	9
Weekly Fryer Cleaning.....	10
Thermostat Calibration Check .....	10
Thermostat Calibration .....	11
Filling The Fryer With Liquid Shortening .....	11
Filling The Fryer With Solid Shortening .....	11
Fryer Shut-Down .....	11

# **INSTALLATION**

## **Checking And Unpacking Your New Appliance**

Your new Pitco appliance has been carefully packed into one crate. Every effort has been made to ensure that it is delivered to you in perfect condition. Pitco does not assume responsibility for damage or loss incurred in transit.

1. Upon Delivery, inspect for visible shipping damage in the presence of the trucking operator. If something appears damaged, file a claim for damages regardless of extent.
2. Unpack and inspect unit for damage. Contact the shipper within 15 days and file a concealed damage claim; the shipper is only responsible for concealed damage for 15 days after delivery.
3. Remove the unit from the shipping pallet:
  - a: Remove the filter pan, and JIB pan from unit before attempting to dismount the unit from the shipping base.
4. Do not allow the full weight of the unit to rest on the legs or caster when removing the appliance from the shipping pallet. The casters can be bent or damaged if too much weight or force is applied to them from improper handling.
5. Check the packing list enclosed with your appliance to ensure that you have received all the parts to the appliance. If you are missing any parts, contact the dealer from whom the appliance was purchased.
6. Using the front cover of this manual, record the following for warranty service or future reference: 1. Your Pitco model number. 2. Fryer serial numbers (Found on the inner door of each fryer). 3. The date purchased from your dealer invoice.

Once you have completed the above, the appliance is ready to be installed.

## **Installation Clearances**

The clearances shown below are for combustible and non-combustible installations and will allow for safe and proper operation of your appliance.

	<b>Combustible Construction</b> Inches (centimeters)	<b>Non Combustible Construction</b> Inches (centimeters)
<b>Back</b>	6.0" (15.2cm)	0.0" (0.0cm)
<b>Sides</b>	6.0" (15.2cm)	0.0" (0.0cm)
<b>Floor</b>	9" (22.86 cm)	9" (22.86 cm)

In addition to the above clearances there must also be at least 30 inches (76.2cm) of aisle space in front of the unit.

### **WARNING**

DO NOT obstruct the flow of ventilation air openings around the appliance. Adequate clearance around the appliance is necessary for servicing and proper component ventilation. Ensure that you meet the minimum clearance requirements specified in this manual.

### **WARNING**

DO NOT install this appliance next to a water cooker, or use in any way in which water can come in contact with the hot oil. Splash over of water into hot oil may result in a steam eruption, potentially causing hot oil to be ejected from the fryer, and creating a burn hazard.

## Leveling The Fryer – Legs/Casters

### CAUTION

To prevent equipment damage and/or personal injury, do not tilt the appliance onto any two of its casters or legs, or pull the appliance by the splash back.

### WARNING

This appliance must be installed with the legs or casters provided by the manufacturer.

### WARNING

DO NOT perform leveling procedure when appliance is in operation or full of hot liquids. Serious injury could result.

When you receive your appliance it is completely assembled with legs or optional casters. This appliance must be installed with legs or casters; it cannot be curb mounted, or sealed to a base. Curb mounting will seriously inhibit this appliance's ability to effect proper component ventilation. The supplied legs or casters provide the necessary height to meet sanitation requirements and assure adequate air supply for electrical component ventilation. To level the fryer, use the following procedure.

Required tools: Large pair of water pump pliers, Medium flat blade screwdriver, level 12" long max.

- 1 Position appliance in final installed location.
- 2 Apply level across front, and then the left and right side of unit, determine lowest point, and distance to level.
- 3 Add the distance determined in step 2 to caster or leg on the lowest corner of appliance.
  - a. Swivel casters- loosen 2 set screws (A)
  - b. Legs and swivel casters-. Adjust the height of the leg / caster by turning adjustment collar/ foot (B) with water pump pliers until desired change in height is achieved.
  - c. Swivel casters only: Retighten set screws (A).
  - d. Fixed casters- Adjust height by moving wheel and axle to alternate holes in wheel bracket higher or lower as needed. Refer to Figure 3C "FIXED" type caster.
- 4 Adjust remaining casters or legs as needed to insure the appliance is supported evenly at each caster/leg contact point.

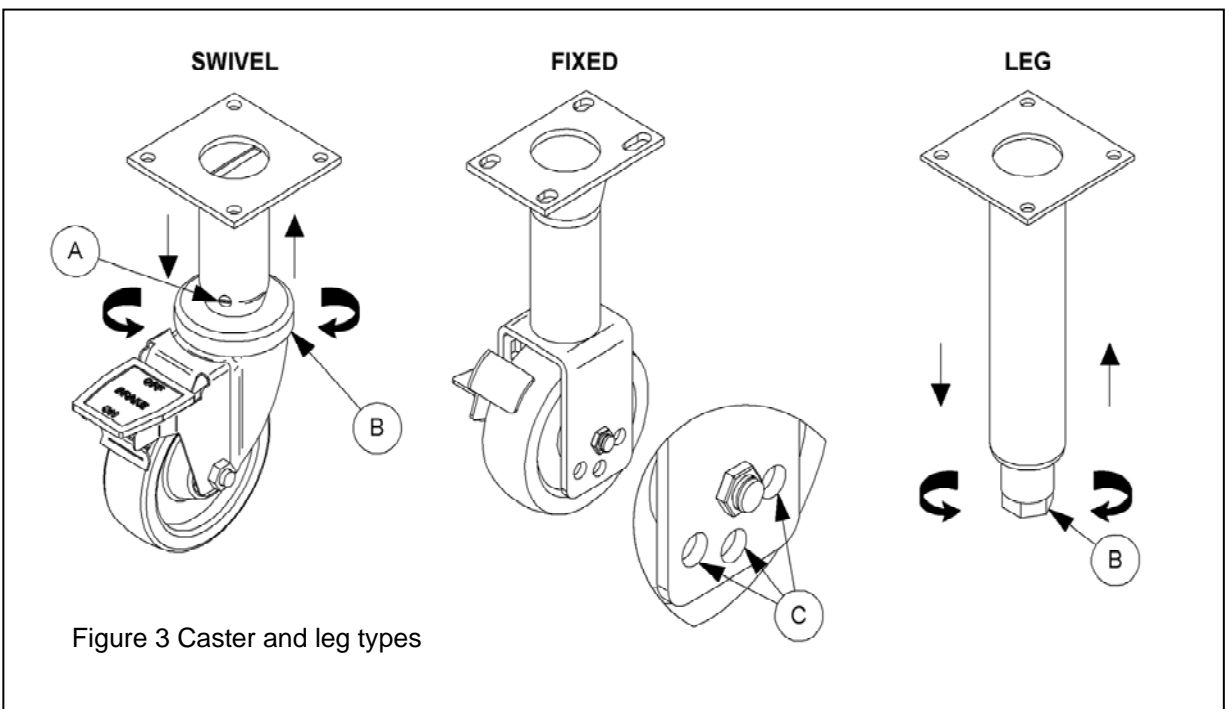

## Gas Connection

Your fryer will give you peak performance when the gas supply line is of sufficient size to provide the correct gas flow. The gas line must be installed to meet the local building codes or National Fuel Gas Code ANSI Z223.1 Latest Edition. In Canada, install the fryer in accordance with CAN/CGA-B149.1 or .2 and local codes. Gas line sizing requirements can be determined by your local gas company by referring to National Fuel Gas Code, Appendix C, Table C-4 (natural gas) and Table C-16 (propane). The gas line needs to be large enough to supply the necessary amount of fuel to all appliances without losing pressure to any appliance.

### WARNING

**NEVER** supply the fryer with a gas that is not indicated on the data plate. Using the incorrect gas type will cause improper operation. If you need to convert the fryer to another type of fuel, contact your dealer.

## Fuel Types

Each fryer is equipped to work with one type of fuel. The type of fuel with which the appliance is intended to operate is stamped on the data plate attached to the inside of the door.

### NOTICE

**NEVER** use an adaptor to make a smaller gas supply line fit the cooker connection. This may not allow proper gas flow for optimum burner operation, resulting in poor cooker performance.

## Quick Disconnect Gas Connection

Gas fryers equipped with casters must be installed with connectors that comply with the Standard for Connectors for Movable Gas Appliances, ANSI Z223.1 Latest Edition, and Addenda Z21.69A Latest Edition. This connection should include a quick disconnect device that complies with the Standard for Quick Disconnect Devices for Use With Gas Fuel, ANSI Z223.1 Latest Edition. When installing a quick disconnect you must also install a means for limiting the movement of the fryer. This device will prevent the gas line or the quick disconnect from being strained. The restraining device should be attached to the cooker on the back panel.

## Fuel Supply Line Leak and Pressure Testing

The fuel supply system must be tested before the fryer is used. If the fuel line is going to be tested at a pressure greater than ( $>$ ) 1/2 PSIG (3.45 kPa), make sure that the fryer is disconnected from the fuel line. If the fuel line is to be tested at a pressure equal to or less than ( $\leq$ ) 1/2 PSIG (3.45 kPa), the fryer can be connected but the unit's gas valve must be shut. Test all gas line connections for leaks with a solution of soap and water when pressure is applied.

## Ventilation And Fire Safety Systems

Your new appliance must have proper ventilation to function safely and properly. Exhaust gas temperatures can reach as high as 1100 °F (593 °C). Therefore, it is very important to install a fire safety system. Your ventilation system should be designed to allow for easy cleaning. Frequent cleaning and proper maintenance of the ventilation system and the appliance will reduce the chances of fire. Ventilation and fire safety systems must comply to local and national codes for US and Canada. Refer to ANSI 83.11 for a list of reference documents that will provide guidance on ventilation and fire safety systems. For installations in U.S. and Canada, additional information can be obtained from CSA International, 8501 East Pleasant Valley Road, Cleveland, OH, 44131 or visit their website at [www.csa-international.org](http://www.csa-international.org). In Australia the ventilation system must comply with AS/NZS 5601.0.

It is essential that the appliance be operated only when adequate ventilation is provided. Your ventilation hood should be properly maintained. A qualified installation professional should ensure that the hood is operating properly in conjunction with the appliance. Inadequate ventilation may not properly evacuate appliance all emissions. Excessive or unbalanced ventilation may cause drafts, which could interfere with proper operation of the pilot and burners. Leave at least 18 inches (47cm) of open space between the flue of the appliance and the intake of the exhaust hood.

### WARNING

Ensure that your ventilation system does not cause a down draft at the appliance's flue opening. A down draft will not allow the appliance to exhaust properly and will cause overheating, which may cause permanent damage. Damage caused by down drafts will not be covered by the warranty. NEVER allow anything to obstruct the flow of combustibles or ventilation exiting the appliance. NEVER place anything on top of the flue area, or block the flue in any way. Never place a grease condensing drip pan over the flue opening.

### WARNING

NEVER connect the ventilation blower or hood directly to the flue of this appliance. The resulting increased flow of air through the combustion system will cause improper operation, poor temperature recovery, poor ignition and could extinguish the pilot.

### WARNING

Replacing or adding appliances under a pre-existing fire safety system may require modifications to the system. ALWAYS contact a professional who is qualified in installing, designing and maintaining your fire safety system to assure that any appliances located under the fire safety system are adequately protected.

If installed in Australia the fryer must be installed in accordance with AS/NZS 5601, local authority and any other relevant statutory regulations. Flexible hose (if used) must comply with AS/NZS 1869 Class B or D, be of appropriate internal diameter, be kept as short as possible (not exceed 1.2 meters), must not be kinked and not be in contact with a hot surface. A chain must be fitted to restrict the fryer movement to no more than 80% of the hose length.

### NOTICE

NEVER connect the blower directly to the flue openings. The direct flow of air will cause poor temperature recovery, poor ignition, inefficient operation of the fryer, and could extinguish the pilot.

## Gas Line Requirements

A properly installed gas supply system will deliver  $7.0 \pm 2.0$ " w.c. natural gas ( $12.0 \pm 2.0$ " w.c. LP) to all appliances connected to the line, operating at full demand.

### NOTICE

Do NOT exceed 13.5" W.C. pressure as damage may occur to the gas valve



## Lighting Instructions

- a. Fill kettle before lighting.
- b. Turn combination gas valve knob to "PILOT" position.
- c. Depress valve knob and light pilot. With pilot burning, hold knob depressed for 60 seconds.
- d. Release knob, pilot should remain lit.
- e. DO NOT TURN COMBINATION GAS VALVE KNOB TO THE "ON" POSITION UNTIL VESSEL IS FULL OF WATER OR SHORTENING. TURNING THE KNOB TO "ON" WITH VESSEL EMPTY WILL DAMAGE THE VESSEL OR COMPONENTS AND VOID WARRANTY.

Relighting - wait 5 minutes before attempting to relight the pilot to allow for any gas in the fryer to dissipate.

## Initial Cleaning

When the fryer is shipped, many of its parts are covered with a thin coat of oil for protection. Before the fryer is ready for cooking it must be cleaned. This will remove the oil coating and any foreign matter that may have accumulated during storage and shipment. Perform the cleaning as described below.

- a. Fill the vessel with water.
- b. Turn the fryer gas valve knob to the "ON" position. Allow the fryer to bring the water to a low boil and add one packet of Pitco fryer cleaner or a mild, low sudsing detergent and allow water to continue to boil for a minute, making sure water does not boil over.
- c. Turn the gas valve knob to the "PILOT" position and allow fryer to soak with the hot water for 15 minutes.
- d. Using the fryer cleaning brush, scrub the inside of the fryer to remove protective coating.
- e. When cleaning is complete, turn the gas valve knob to the "OFF" position and drain the water into a container suitable for hot water and dispose of it.
- f. When the tank has cooled, rinse it thoroughly with cool water. Continue to rinse the tank until the cleaner has been rinsed, thoroughly from the tank.
- g. Using a clean dry cloth, wipe out all of the water. Be very thorough removing the water, because any residual water will cause hot oil to splatter out of the fryer. Close the drain valve and remove container.
- h. Now that the tank is clean, you are ready to fill and operate the fryer. Refer to instructions on adding shortening to the fryer.

### NOTICE

Do not leave the fryer unattended during cleaning. Never let the water level go below the "Min Level" mark on the back of the tank

### CAUTION

Mild steel tanks must be wiped down/coated with oil to keep the tank from rusting.

## Daily Cleaning

Should be performed to maintain peak operation and appearance.

- a. Wipe up any shortening that spills onto the exterior of the fryer. This should be done with a clean soft cloth while the oil is still warm.
- b. Use warm water with a mild detergent to clean surfaces. Be careful not to get water in the shortening and to remove any detergent from the fry tank.
- c. Use a nonabrasive scouring powder or pad to clean stains if necessary.
- d. Perform the weekly boil out cleaning of your fryer described below.

## Weekly Fryer Cleaning

This cleaning should include a complete draining of the fryer and a boil out.

- a. You will need a container large enough to hold 1 1/2 times the oil in one tank. This container should also be able to withstand 400<sup>0</sup> F oil temperatures.
- b. Shut fryer gas system OFF completely before performing procedures to ensure unit does not come on during any part of the cleaning operation.
- c. Drain the oil from the fryer and discard or save for reuse. Remove tube rack/mesh tube screens and remove any large debris from the bottom of the fry tank. Once clean, return tube rack/mesh screens to the fry tank. Close the drain valve and fill the fry tank with water and noncaustic detergent. Relight gas system pilot, following the lighting instructions.
- d. Turn the fryer gas valve knob to the "ON" position. Allow the fryer to bring the water to a low boil and add one packet of Pitco fryer cleaner or a mild, low sudsing detergent and allow water to continue to boil for a minute, making sure water does not boil over.
- e. Turn the gas valve knob to the "PILOT" position and allow fryer to soak with the hot water for 15 minutes.
- f. Using the fryer cleaning brush, scrub the inside of the fryer to remove protective coating.
- g. When cleaning is complete, turn the gas valve knob to the "OFF" position and drain the water into a container suitable for hot water and dispose of it.
- h. When the tank has cooled, rinse it thoroughly with cool water. Continue to rinse the tank until the cleaner has been rinsed, thoroughly from the tank.
- i. Using a clean dry cloth, wipe out all of the water. Be very thorough removing the water, because any residual water will cause hot oil to splatter out of the fryer. Close the drain valve and remove container.
- j. Now that the tank is clean, you are ready to fill and operate the fryer. Refer to instructions on adding shortening to the fryer.

### WARNING

Gas units installed with casters must have a restraining device. This device must be connected at all times that the fryer is connected to the gas supply. If it is disconnected for any reason, it must be reconnected

## Thermostat Calibration Check

### NOTICE

Thermostat calibration requires that the temperature of the fryer be raised above boiling. Therefore, you will need to drain the water from the fryer and fill it with oil. Before removing the water, perform the initial cleaning of the fryer. Cleaning the fryer now will prevent you from having to drain the oil and refill with water later.

To perform the calibration check detailed below you will need a digital thermometer.

- a. Place the tip of the thermometer in the shortening approximately 1" above the temperature sensors.
- b. Set the thermostat at 325°F and wait for the temperature reading on the thermometer to rise. As the temperature rises toward 325°F watch the thermometer closely.
- c. If the shortening temperature reaches 350°F and the burners DO NOT turn off, turn the thermostat down. Keep lowering the thermostat setting until the burners go out.

### CAUTION

If the burners do not turn off at the lowest thermostat setting, the thermostat could be defective. Contact your representative immediately

- d. Let the fryer cycle 4 to 6 times before checking the temperature. Compare the thermometer temperature against the thermostat setting. If the values are more than 5°F apart, calibrate the thermostat using the appropriate calibration procedure in this manual.

## Thermostat Calibration

Millivolt thermostats

- a. Set the thermostat dial to 325° F.
- b. Remove the thermostat dial by pulling the knob straight out. DO NOT rotate the dial.
- c. Hold the outside of the shaft so it does not move. Use the tip of a small, flat tip screw driver to scrape away the sealing compound from the adjustment screw.
- d. Turn the adjustment screw clockwise to lower the temperature setting and counterclockwise to raise the temperature. One quarter turn changes the temperature approximately 25° F.
- e. Turn the adjustment until the burners turn on at 325° F. Replace the knob and allow the fryer to cycle 4 to 6 times. Check the temperature of the thermometer against the thermostat dial. If it is greater than 5° F difference, repeat the calibration procedure.
- f. When the calibration is correct, remove the thermometer and replace the tube screen.

## Filling The Fryer With Liquid Shortening

- a. Make sure the drain valve is completely closed.
- b. Fill the fryer with oil to the "Oil Level" line marked on the back of the tank.

## Filling The Fryer With Solid Shortening

- a. Make sure the drain valve is completely closed.
- b. Remove the screen covering the tubes.
- c. Cut the shortening into cubes no larger than 1". ALWAYS pack the shortening below, between, and on top of the burner tubes. DO NOT leave any large air gaps. Use care when packing the solid shortening in the tank. DO NOT bend or break the temperature sensor probes. If these are damaged the fryer will not function properly.
- d. Once the fryer is packed with shortening, the shortening must be melted.
- e. To melt shortening, manually pulse the burners ON and OFF using the thermostat until the shortening is liquidized enough to cover the heat tubes. This will protect the tank and components from damage and extend the life of the oil.

## Fryer Shut-Down

There are two shutdown modes of fryer operation, STANDBY and COMPLETE. The standby mode removes the ability for the fryer's main burners to cycle. Complete shutdown turns off the gas supply to the fryer. Shut down the fryer by:

**STANDBY** Turn the thermostat to OFF. Turn the gas valve clockwise to the PILOT position. The cooker is now in Standby and can remain this way for only brief periods of time. NEVER leave the cooker in standby overnight.  
**COMPLETE** To completely shut down the cooker, push and turn the gas valve counterclockwise to the OFF position. The fryer is now completely shut down and can be cleaned and filtered.



In the event of problems with or questions about your order, please contact the Pitco Frialator factory at:  
(603)-225-6684 World Wide  
Website Address: [www.pitco.com](http://www.pitco.com)

In the event of problems with or questions about your equipment, please contact the Pitco Frialator Authorized Service and Parts representative (ASAP) covering your area, or contact Pitco at the number listed to the left.

MAILING ADDRESS – P.O. BOX 501, CONCORD, NH 03302-0501  
SHIPPING ADDRESS – 10 FERRY STREET, CONCORD, NH 03301