

SERVICE SECTION



There's Always Something Cooking!

Service, Parts, and Schematics
For Reversible Pump Filter Systems

Covering Models
RP-14 & RP-18

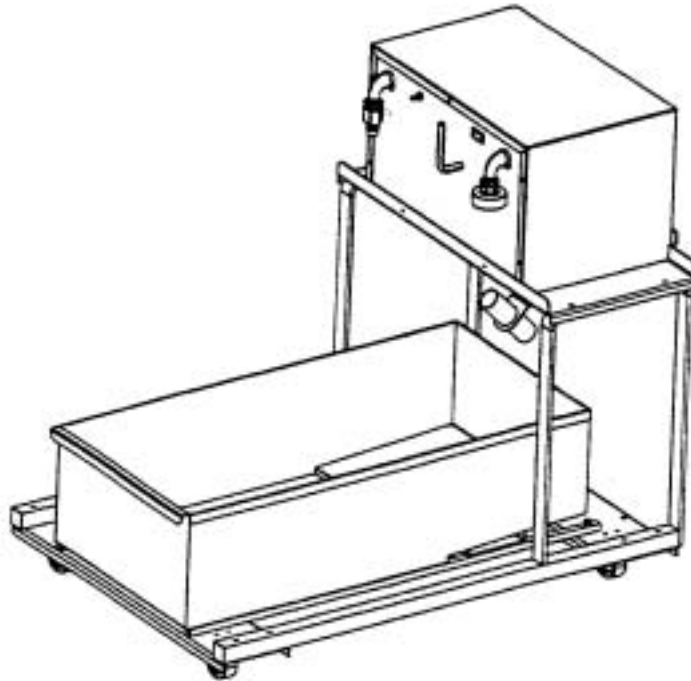

Table of Contents

Section	Title	Page
	Table of Contents (Service)	i
	List of Tables and Figures	ii
Chapter 4: Service		4-1
4.1	REPLACEMENT PROCEDURES	4-1
4.1.1	Pump/Motor Removal	4-1
4.2	TROUBLESHOOTING FILTER SYSTEMS	4-2
Chapter 5: Parts		5-1
	ALPHABETICAL PART LIST	5-5
	NUMERICAL PART LIST	5-7
Chapter 6: Schematics		6-1

List of Tables and Figures

Figure	Title	Page
5-1	Reversible Pump Filter System	5-4

Table No.	Title	Page
5-1	Reversible Pump Filter System	5-1

Chapter 4: Service

This chapter provides the qualified technician with the replacement and troubleshooting procedures necessary to service the Pitco filter system.

4.1 REPLACEMENT PROCEDURES

These procedures are provided to the qualified technician as a guide to removal and replacement of various filter system components. If a test is required to verify component operation after installation, it will be referenced.

4.1.1 Pump/Motor Removal

1. Remove the screws to the motor cover. (10 total)
2. Remove the cover from the unit.
3. Loosen both unions on each side of the pump head.
4. Remove the hex nuts and washers from the motor base (4 total).
5. Cut and remove the white electrical tape that holds the heat tape to the pump head. (Heater Option Only)
6. Remove the orange heat tape wrapped around the pump head. (Heater Option Only)
7. Remove the motor electrical door at the rear of the motor.
8. Remove all wirenuts leading to the motor.
9. Remove valve handle by removing the nut on the valve.
10. The pump/motor can be removed by raising the pump/motor straight up over the studs and twisting out.
11. Replace by reversing above procedures.

4.2 TROUBLESHOOTING FILTER SYSTEMS

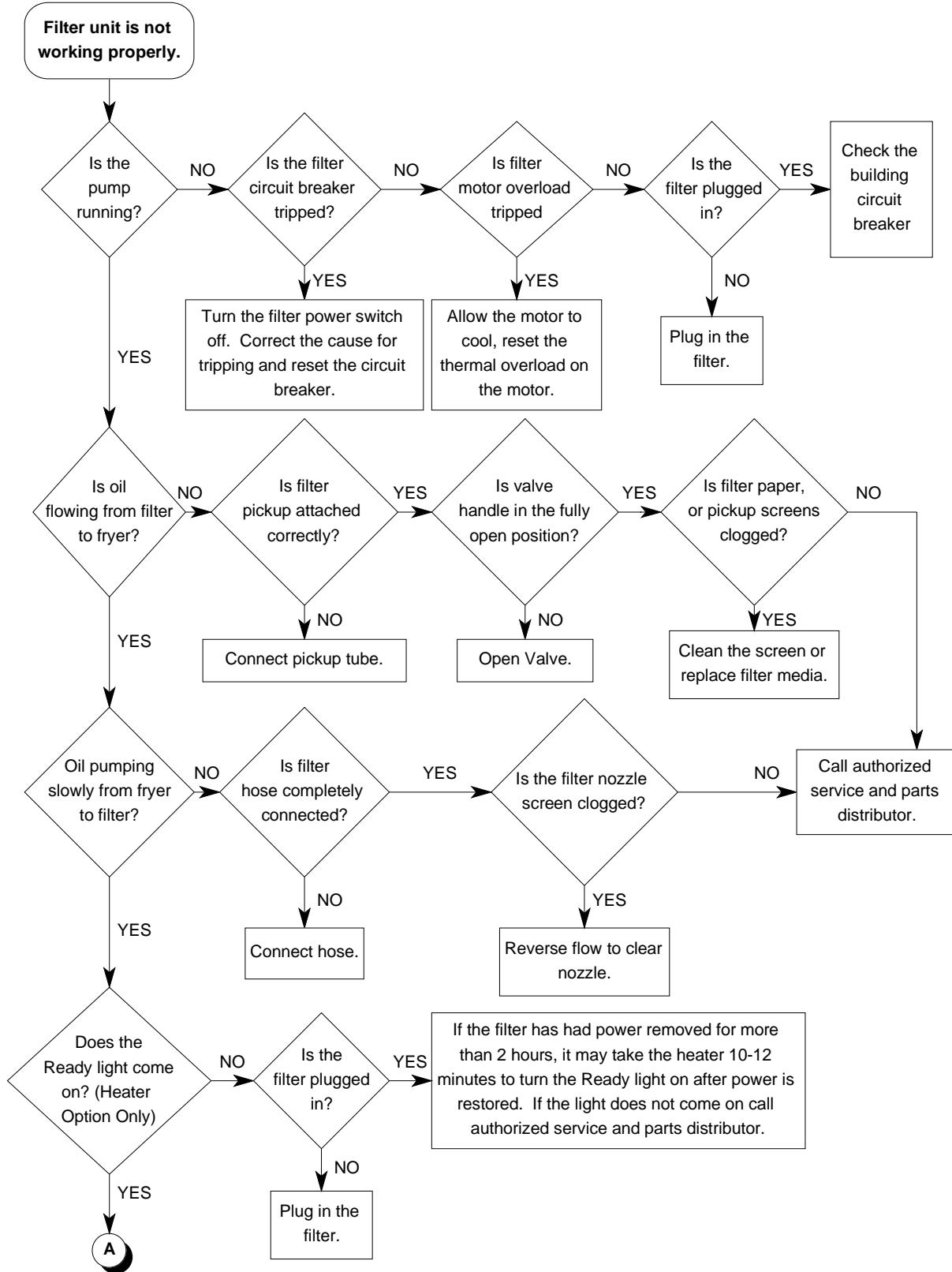

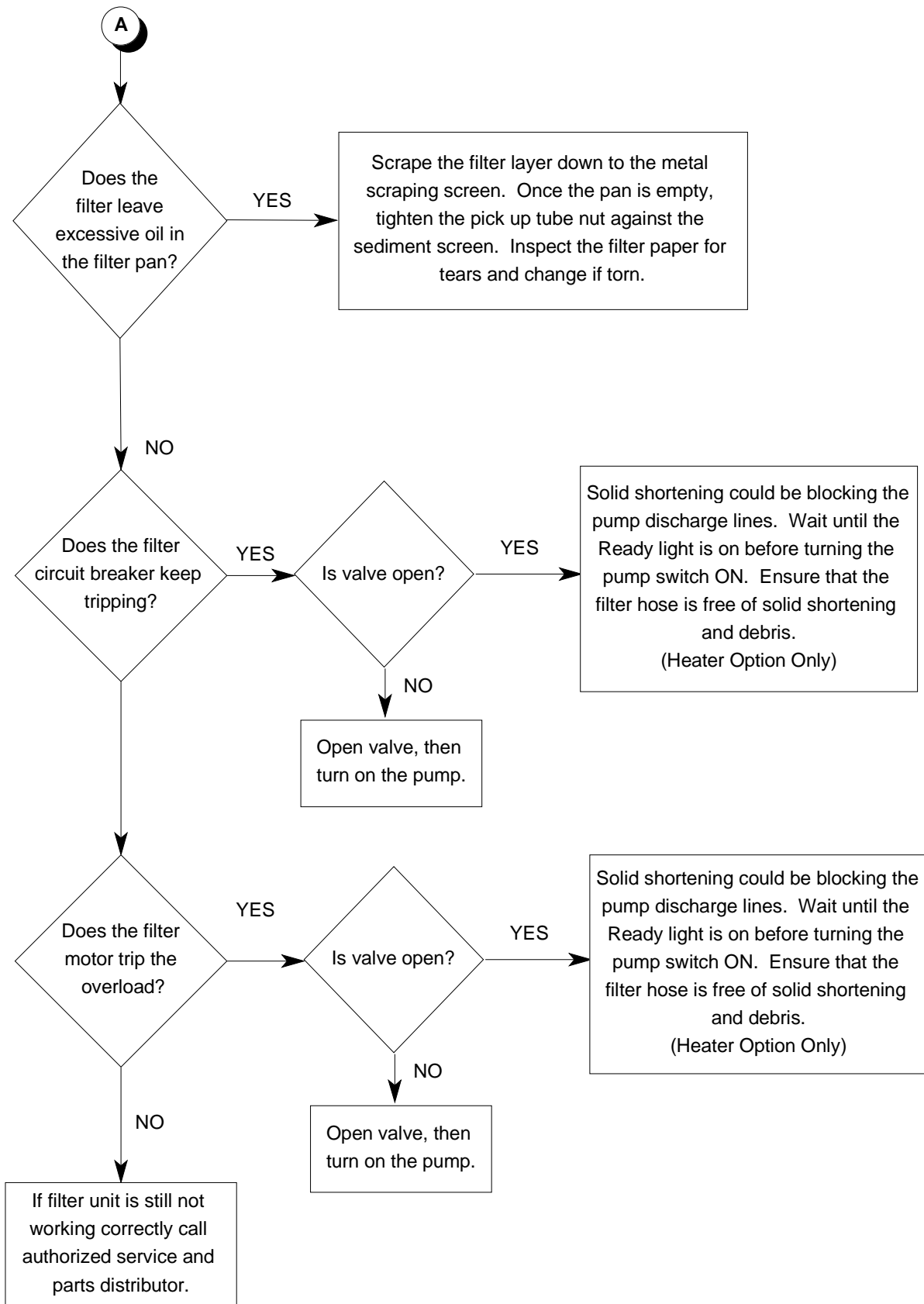

Chapter 5: Parts

This chapter contains listings of the components used in the different models of filter systems. These components are listed in two places, with the illustration and in ordered listings. The illustrations in this chapter are provided to show relative location of components located in the fryer. The filter system you have may not be illustrated in this chapter, but the part locations should be the same. With each illustration there is a table of components in numerical order by illustration number. The illustration has numbered lines pointing to components which are listed in the table.

At the end of this chapter there are alphabetical and numerical listings of all parts used in the filter systems. The alphabetical part list is arranged in alphabetical order according to the part name. Each part name also has the Pitco Frialator part number. The numerical list is in Pitco Frialator part number order. A brief description of each component is provided for each part.

Table 5-1 Reversible Pump Filter System

Item Number	Pitco Frialator Part Number	Description	Quantity Per Unit
1	B7402601	Filter Carriage Frame #14	1
	B7402701	Filter Carriage Frame #18	1
1A	P5045160	Cap, Plastic	1
1B	P6071062	Caster, PMF 2 (W/Top Plate)	2
2	B6602405	Filter, Hose Hi-Pressure 60"	1
3	B6624701	Filter, Nozzle Weldment RP14,RP18	1
4	P6071190	Handle, Nozzle Rack	1
5	P0095200	Nut, Hex (Jam) 3/8-16	1
6	B6604501	Filter, Connector Quick	1
7	B6624801	Filter, Screen Inlet	1
8	PP10820	Ring, Retaining-Internal	1
9	B6627101	Filter, Plate Motor Weldment RP14	1
10	B6625501	Filter, Motor PC Assy, 115 VAC RP14, RP18	1
10A	PP10101	Pump/Motor, 1/3 HP, 115/230VAC, 50/60Hz	1
10B	P6071757	Valve, Ball 1/2", 3-Way	1
* 10C	A6688402	Filter, Bracket, T-Stat, RP14,RP18	1
10D	A6689002	Filter, Bracket Switch, Micro RP14,RP18	1
* 11	PP10039	Heater, Tape 165W, 110 VAC, 1/2" x 79"	1
12	B6625801	Filter, Cover Motor Weldment, RP14,RP18	1
13	A6688102	Filter, Panel Front RP14,RP18	1
14	A6688202	Filter, Panel Rear RP14,RP18	1
15	B6627001	Filter, Handle Weldment, RP14,RP18	1
16	P7037752-1	Elbow, Street 3/8" 90° Plated	2
17	P6071123	Connector, Filter 3/8" Male	1
18	PP10113	Connector, Coupler-Valved 3/8"	2
19	P6071253	Filter, Handle, Snap Tite White	1
20	P0062100	Set Screw, 1/4-20 x 3/8"	2
21	P6071490	Plug, Hole 7/8"	1
22	PP10146	Connector, Strain Relief	1
23	PP10686	Screw, 6-32 x 1/4"	2
24	P0091100	Nut, Hex 6-32	4
25	A6657202	Filter, Bracket Electric Cord	1
26	PP10752	Screw, 10-32 x 1/2"	14
27	P0020600	Screw, 1/4-20 x 5/8"	4
28	PP10668	Nut Acorn 1/4-20	4
29	P0080650	Washer, Flat 1/4"	4
30	P0093300	Nut, Hex, 1/4-20	4
31	Call Factory	Tubing, fluoropolymer 5/8 ID x 11/16 OD	Order By Length

Revised 12/27/93

Table 5-1 Reversible Pump Filter System (Continued)

Item Number	Pitco Frialator Part Number	Description	Quantity Per Unit
32	B6624901	Filter, Pan Weldment RP14	1
	B6624902	Filter, Pan Weldment RP18	1
33	B6620002	Filter, Rack Weldment RP14,RP18	1
34	B6617002	Filter, Screen Clip RP14,RP18	1
35	A6681802	Filter, Coupling Top	1
36	B6615301	Filter, Screen Inlet	1
37	PP10409	O-Ring, Viton .688 ID x .875 OD	1
38	PP10629	Ring, Retaining-Internal .875"	1
39	B6625601	Filter, Tubing Suction Weldment RP14	1
	B6625602	Filter, Tubing Suction Weldment RP18	1
40	P7037796	Coupling, Black 3/8" NPT x 1/2" Tube	1
41	P6071254	Filter, Handle Snap Tite Black	1
42	P0006300	Screw, 6-32 x 1"	2
43	PP10821	Switch, Toggle 3PDT	1
* 44	PP10331	Lamp, 125 VAC, Green, Rect.	1
	PP10736	Lamp, 250 VAC, Green, Rect.	1
45	P5047171	Switch, Limit-SPST	1
46	PP10460	Switch, Rocker Ckt Bkr SPST, 8A 250VAC	1
	PP10470	Switch, Rocker Ckt Bkr SPST, 4A 250VAC	1
47	PP10139	Cord, Plug, 14-3, 10'	1
* 48	PP10739	Tstat, Snap Disk 135°F Open, 105°F Close	1
		* HEATER OPTION ONLY	

Revised 12/27/93

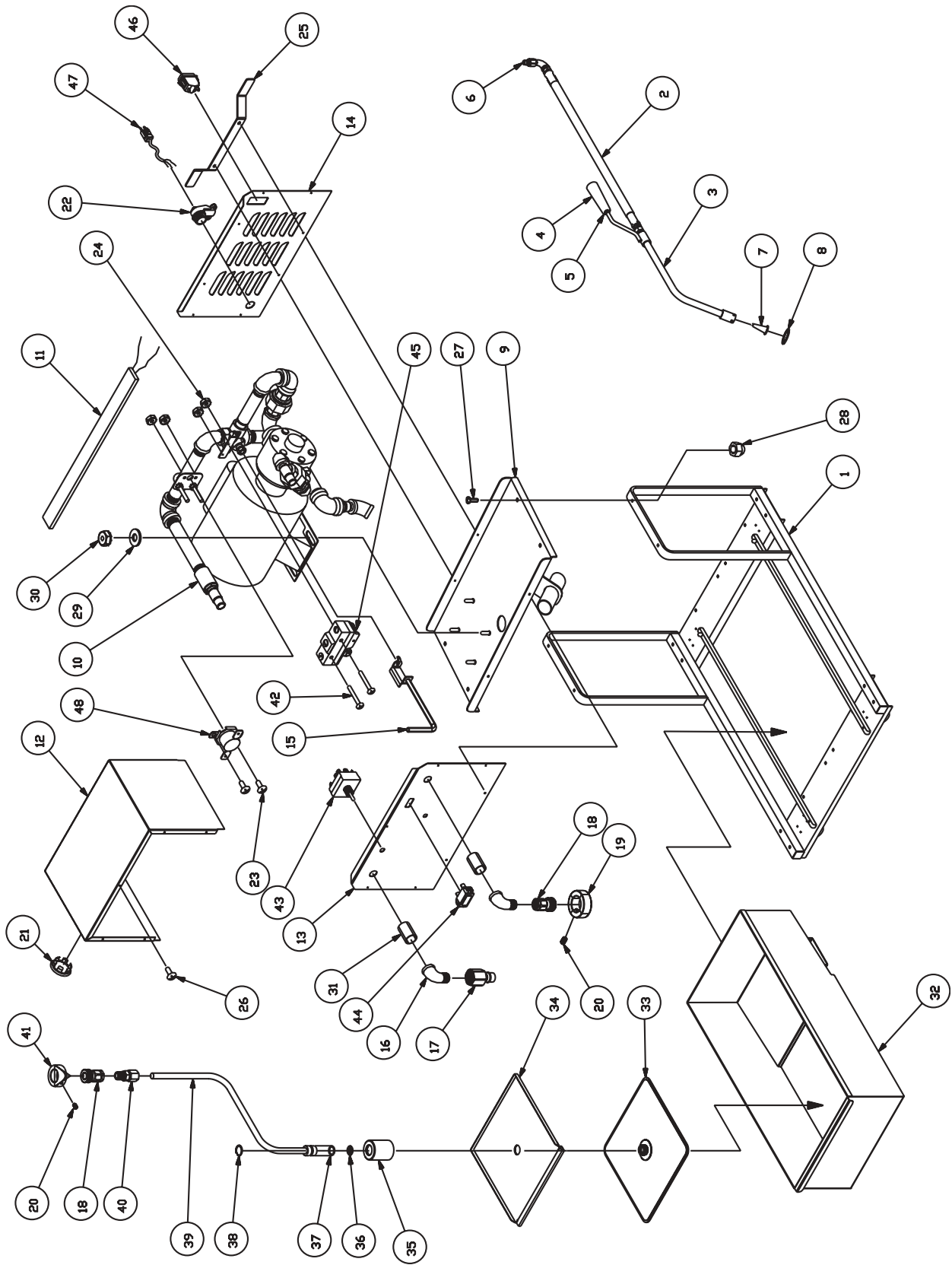

Figure 5-1 Reversible Pump Filter System

ALPHABETICAL PART LIST

Part Description	Pitco Frialator Part No.
CAP, PLASTIC	P5045160
CASTER, PMF 2 (W/TOP PLATE)	P6071062
CONNECTOR, COUPLER-VALVED 3/8"	PP10113
CONNECTOR, FILTER 3/8" MALE	P6071123
CONNECTOR, STRAIN RELIEF	PP10146
CORD, PLUG, 14-3, 10'	PP10139
COUPLING, BLACK 3/8" NPT X 1/2" TUBE	P7037796
ELBOW, STREET 3/8" 90° PLATED	P7037752-1
FILTER CARRIAGE FRAME #14	B7402601
FILTER CARRIAGE FRAME #18	B7402701
FILTER, BRACKET ELECTRIC CORD	A6657202
FILTER, BRACKET SWITCH, MICRO RP14,RP18	A6689002
FILTER, BRACKET, T-STAT, RP14,RP18	A6688402
FILTER, CONNECTOR QUICK	B6604501
FILTER, COUPLING TOP	A6681802
FILTER, COVER MOTOR WELDMENT, RP14,RP18	B6625801
FILTER, HANDLE SNAP TITE BLACK	P6071254
FILTER, HANDLE WELDMENT, RP14,RP18	B6627001
FILTER, HANDLE, SNAP TITE WHITE	P6071253
FILTER, HOSE HI-PRESSURE 60"	B6602405
FILTER, MOTOR PC ASSY, 115 VAC RP14, RP18	B6625501
FILTER, NOZZLE WELDMENT RP14,RP18	B6624701
FILTER, PAN WELDMENT RP14	B6624901
FILTER, PAN WELDMENT RP18	B6624902
FILTER, PANEL FRONT RP14,RP18	A6688102
FILTER, PANEL REAR RP14,RP18	A6688202
FILTER, PLATE MOTOR WELDMENT RP14	B6627101
FILTER, RACK WELDMENT, RP14,RP18	B6620002
FILTER, SCREEN CLIP, RP14,RP18	B6617002
FILTER, SCREEN INLET	B6624801
FILTER, SCREEN INLET SF50/65 WKS	B6615301
FILTER, TUBING SUCTION WELDMENT RP14	B6625601
FILTER, TUBING SUCTION WELDMENT RP18	B6625602
HANDLE, NOZZLE RACK	P6071190
HEATER, TAPE 165W, 110 VAC, 1/2" X 79"	PP10039
LAMP, 125 VAC, GREEN, RECT.	PP10331
LAMP, 250 VAC, GREEN, RECT.	PP10736
NUT ACORN 1/4-20	PP10668
NUT, HEX (JAM) 3/8-16	P0095200
NUT, HEX 6-32	P0091100

ALPHABETICAL PART LIST (Continued)

Part Description	Pitco Frialator Part No.
NUT, HEX, 1/4-20	P0093300
O-RING, VITON .688 ID X .875 OD	PP10409
PLUG, HOLE 7/8"	P6071490
PUMP/MOTOR, 1/3 HP, 115/230VAC, 50/60HZ	PP10101
RING, RETAINING-INTERNAL	PP10820
RING, RETAINING-INTERNAL .875"	PP10629
SCREW, 1/4-20 X 3/8"	P0062100
SCREW, 1/4-20 X 5/8"	P0020600
SCREW, 10-32 X 1/2"	PP10752
SCREW, 6-32 X 1/4"	PP10686
SET SCREW, 6-32 X 1"	P0006300
SWITCH, LIMIT-SPST	P5047171
SWITCH, ROCKER CKT BKR SPST, 4A 250VAC	PP10470
SWITCH, ROCKER CKT BKR SPST, 8A 250VAC	PP10460
SWITCH, TOGGLE 3PDT	PP10821
TSTAT, SNAP DISK 135°F OPEN, 105°F CLOSE	PP10739
TUBING, fluropolymer 5/8 ID X 1 1/16 OD	CALL FACTORY
VALVE, BALL 1/2", 3-WAY	P6071757
WASHER, FLAT 1/4"	P0080650

NUMERICAL PART LIST

Pitco Frialator Part No.	Part Description
A6657202	FILTER, BRACKET ELECTRIC CORD
A6681802	FILTER, COUPLING TOP
A6688102	FILTER, PANEL FRONT RP14,RP18
A6688202	FILTER, PANEL REAR RP14,RP18
A6688402	FILTER, BRACKET, T-STAT, RP14,RP18
A6689002	FILTER, BRACKET SWITCH, MICRO RP14,RP18
B6602405	FILTER, HOSE HI-PRESSURE 60"
B6604501	FILTER, CONNECTOR QUICK
B6615301	FILTER, SCREEN INLET
B6617002	FILTER, SCREEN CLIP RP14,RP18
B6620002	FILTER, RACK WELDMENT RP14,RP18
B6624701	FILTER, NOZZLE WELDMENT RP14,RP18
B6624801	FILTER, SCREEN INLET
B6624901	FILTER, PAN WELDMENT RP14
B6624902	FILTER, PAN WELDMENT RP14
B6625501	FILTER, MOTOR PC ASSY, 115 VAC RP14, RP18
B6625601	FILTER, TUBING SUCTION WELDMENT RP14
B6625602	FILTER, TUBING SUCTION WELDMENT RP18
B6625801	FILTER, COVER MOTOR WELDMENT, RP14,RP18
B6627001	FILTER, HANDLE WELDMENT, RP14,RP18
B6627101	FILTER, PLATE MOTOR WELDMENT RP14
B7402601	FILTER CARRIAGE FRAME #14
B7402701	FILTER CARRIAGE FRAME #18
P0006300	SCREW, 6-32 X 1"
P0020600	SCREW, 1/4-20 X 5/8"
P0062100	SET SCREW, 1/4-20 X 3/8"
P0080650	WASHER, FLAT 1/4"
P0091100	NUT, HEX 6-32
P0093300	NUT, HEX, 1/4-20
P0095200	NUT, HEX (JAM) 3/8-16
P5045160	CAP, PLASTIC
P5047171	SWITCH, LIMIT-SPST
P6071062	CASTER, PMF 2 (W/TOP PLATE)
P6071123	CONNECTOR, FILTER 3/8" MALE
P6071190	HANDLE, NOZZLE RACK
P6071253	FILTER, HANDLE, SNAP TITE WHITE
P6071254	FILTER, HANDLE SNAP TITE BLACK
P6071490	PLUG, HOLE 7/8"
P6071757	VALVE, BALL 1/2", 3-WAY
P7037752-1	ELBOW, STREET 3/8" 90° PLATED

NUMERICAL PART LIST (Continued)

Pitco Frialator Part No.	Part Description
P7037796	COUPLING, BLACK 3/8" NPT X 1/2" TUBE
PP10039	HEATER, TAPE 165W, 110 VAC, 1/2" X 79"
PP10101	PUMP/MOTOR, 1/3 HP, 115/230VAC, 50/60HZ
PP10113	CONNECTOR, COUPLER-VALVED 3/8"
PP10139	CORD, PLUG, 14-3, 10'
PP10146	CONNECTOR, STRAIN RELIEF
PP10331	LAMP, 125 VAC, GREEN, RECT.
PP10409	O-RING, VITON .688 ID X .875 OD
PP10460	SWITCH, ROCKER CKT BKR SPST, 8A 250VAC
PP10470	SWITCH, ROCKER CKT BKR SPST, 4A 250VAC
PP10629	RING, RETAINING-INTERNAL .875"
PP10668	NUT ACORN 1/4-20
PP10686	SCREW, 6-32 X 1/4"
PP10736	LAMP, 250 VAC, GREEN, RECT.
PP10739	TSTAT, SNAP DISK 135°F OPEN, 105°F CLOSE
PP10752	SCREW, 10-32 X 1/2"
PP10820	RING, RETAINING-INTERNAL
PP10821	SWITCH, TOGGLE 3PDT
CALL FACTORY	TUBING, fluoropolymer 5/8 ID X 11/16 OD

Chapter 6: Schematics

Schematic Description	Schematic Number
SCHEMATIC, FILTER RP14, RP18 115 VAC	700160
SCHEMATIC, FILTER RP14, RP18 220 VAC	700161
SCHEMATIC, FILTER RP14, RP18 240 VAC	700162

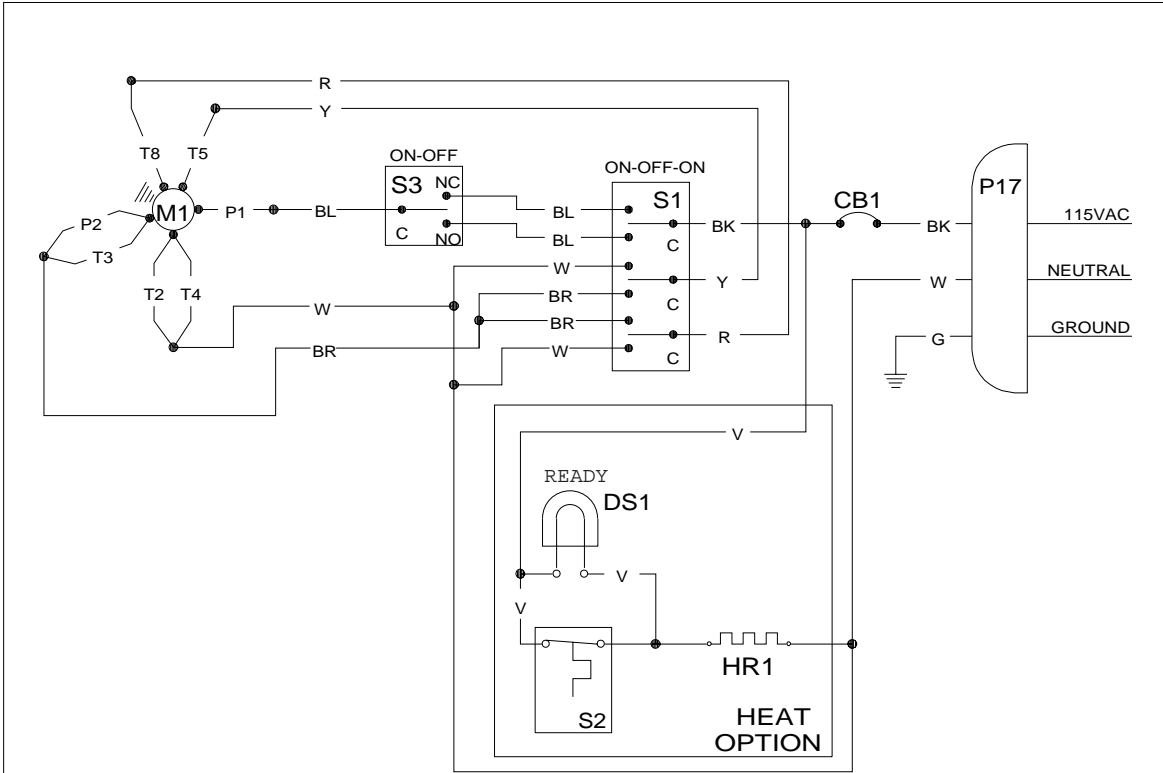

PARTS LIST

NOMENCLATURE	PART NO.	DESCRIPTION	QTY
CB1	PP10460	CIRCUIT BREAKER, SWITCH ROCKER SPST 8AMP 250VAC	1
DS1	PP10331	LAMP, 125VAC GREEN RECTANGLE	1
HR1	PP10039	HEATER, TAPE 165W 110VAC 1/2 X 79	1
M1	PP10101	PUMP/MOTOR, 1/3HP 115/230V 50/60HZ	1
P17	PP10439	CORD, PLUG-MOLDED 14-3 NEMA 5-15P	1
S1	PP10821	SWITCH, TOGGLE 3PDT ON-OFF-ON	1
S2	PP10739	TSTAT, SNAPDISK 135 F OPEN 105 F CLOSE	1
S3	P5047171	SWITCH, LIMIT-SPDT 1-C17	1

THE INFORMATION CONTAINED ON THIS DOCUMENT IS THE PROPERTY OF PITCO FRIALATOR INC. AND MAY NOT BE REPRODUCED, COPIED, OR DISSEMINATED TO THIRD PARTIES WITHOUT THE WRITTEN PERMISSION OF:
 PITCO FRIALATOR INC.
 CONCORD, NH 03301 U.S.A.



PITCO FRIALATOR, INC.
 P.O. BOX 501 CONCORD, NH 03302-0501

TITLE: **SCHEMATIC, FILTER RP14, RP18 115VAC**

MATERIAL	SEE PARTS LIST	TOLERANCES:	N/A
DWG APPROVAL	DATE	PART NO:	N/A
DR: D.P.M.	11/8/93	SCALE:	N/A S1 OF 2
CK:	.	SIZE	DWG NO:
EN NO:	3676	11/12/93	REV
APPD:	.	.	A 700160 03

03	02	01	REV	REVISIONS
3744	3720	3702	EN NO	
12/23/93	12/13/93	11/29/93	DATE	
DPM	NAL	DPM	DR	
.	BHP	BHP	CK	
.	.	.	APPD	

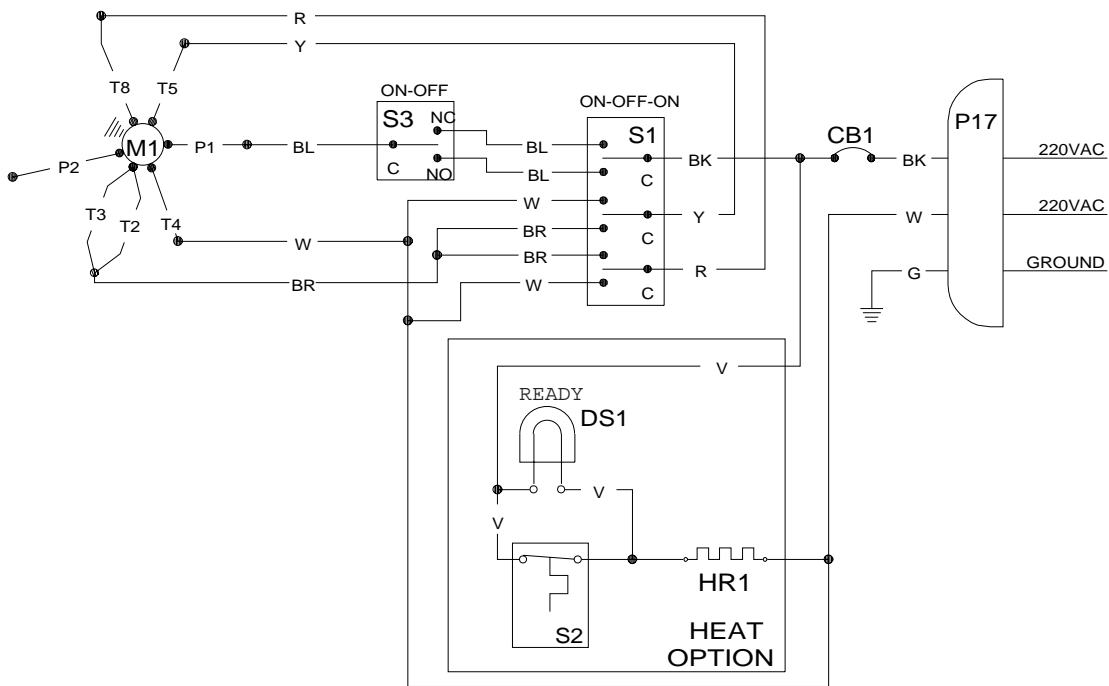

PARTS LIST

NOMENCLATURE	PART NO.	DESCRIPTION	QTY
CB1	PP10470	CIRCUIT BREAKER, SWITCH ROCKER DPST 4AMP 250VAC	1
DS1	PP10736	LAMP, 250VAC GREEN RECTANGLE	1
HR1	PP10080	HEATER, TAPE 165W 240V 1/2 X 79	1
M1	PP10101	PUMP/MOTOR, 1/3 HP 115/230V 50/60HZ	1
P17	PP10439	CORD, PLUG-MOLDED 14-3 NEMA 5-15P	1
S1	PP10821	SWITCH, TOGGLE 3PDT ON-OFF-ON	1
S2	PP10739	TSTAT, SNAPDISK 135 F OPEN 105 F CLOSE	1
S3	P5047171	SWITCH, LIMIT-SPDT 1-C17	1

THE INFORMATION CONTAINED ON THIS DOCUMENT IS THE PROPERTY OF PITCO FRIALATOR INC. AND MAY NOT BE REPRODUCED, COPIED, OR DISSEMINATED TO THIRD PARTIES WITHOUT THE WRITTEN PERMISSION OF:

PITCO FRIALATOR INC.
CONCORD, NH 03301 U.S.A.



PITCO FRIALATOR, INC.
P.O. BOX 501 CONCORD, NH 03302-0501

TITLE:

**SCHEMATIC, FILTER
RP14, RP18 220VAC**

MATERIAL		SEE PARTS LIST		TOLERANCES: N/A	
DWG APPROVAL		DATE		PART NO: N/A	
DR: D.P.M.	11/8/93	SCALE: N/A		SM OF 2	
CK:	.	SIZE	DWG NO:	REV	
EN NO: 3676	11/12/93	A		700161 03	
APPD:	.				

03	02	01	REV	REVISIONS
3744	3720	3702	EN NO	
12/23/93	12/13/93	11/29/93	DATE	
DPM	DPM	DPM	DR	
.	BHP	BHP	CK	
.	.	.	APPD	

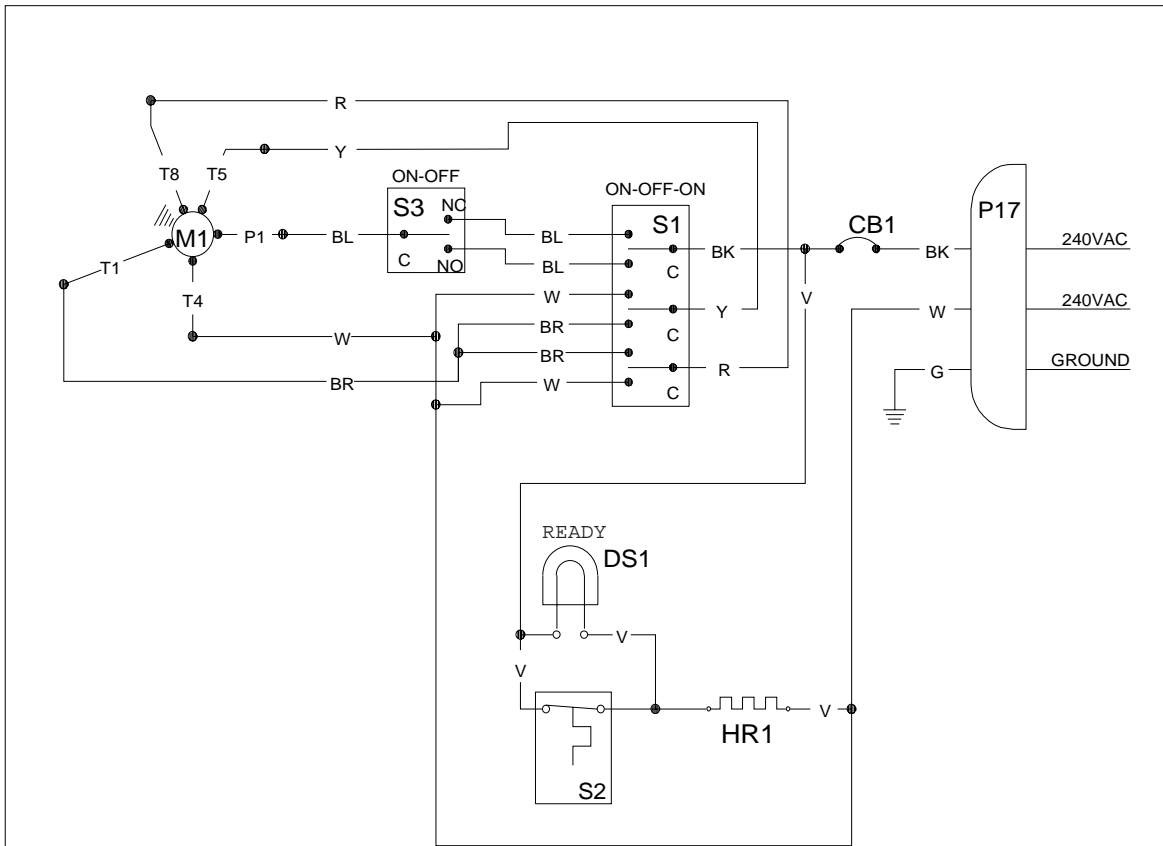

PARTS LIST

NOMENCLATURE	PART NO.	DESCRIPTION	QTY
CB1	PP10470	CIRCUIT BREAKER, 4 AMP-DOUBLE POLE	1
DS1	PP10736	LAMP, 250 VAC-GREEN	1
HR1	PP10080	HEAT TAPE - 240 VAC, 165 W	1
M1	PP10171	PUMP/MOTOR ASSY, 240VAC 50HZ 1/3HP	1
P17	PP10710	CORD, PLUG MOLDED 16-3 NEMA 6-15P 23.5"	1
S1	PP10821	SWITCH, TOGGLE 3PDT ON-OFF-ON	1
S2	PP10739	SWITCH, THERMAL 135 F OPEN 105 F CLOSE	1
S3	P5047171	SWITCH, LIMIT-SPST 1-C17	1

THE INFORMATION CONTAINED ON THIS DOCUMENT IS THE PROPERTY OF PITCO FRIALATOR INC. AND MAY NOT BE REPRODUCED, COPIED, OR DISSEMINATED TO THIRD PARTIES WITHOUT THE WRITTEN PERMISSION OF:

PITCO FRIALATOR INC.
CONCORD, NH 03301 U.S.A.



PITCO FRIALATOR, INC.
P.O. BOX 501 CONCORD, NH 03302-0501

TITLE:

**SCHEMATIC, FILTER
RP14, RP18 240VAC**

01	REV	REVISIONS
3702	EN NO	
11/29/93	DATE	
DPM	DR	
.	CK	
.	APPD	

MATERIAL		SEE PARTS LIST		TOLERANCES:		N/A	
DWG APPROVAL		DATE		PART NO:			
DR: D.P.M.		11/8/93		N/A			
CK:		.		SCALE:		N/A	
EN NO:		3676		SIZE		DWG NO:	
APPD:		.		A		700162	
						S1 OF 2	
						REV	
						03	