



## KleenSteam II Twin System



### STANDARD ACCESSORIES

- 7CB5 Filter Cartridge - 60190901 QTY: 2
- SS-10 ScaleStick - 60191001 QTY: 1

### AVAILABLE OPTIONS & ACCESSORIES At Additional Cost

- 7CB5 Filter Cartridge-60190901
- E20 Coarse Prefilter w/Cartridge-60190801
- EC210 Prefilter Cartridge-60191101
- SS-10 ScaleStick-60191001

### STANDARD SPECIFICATIONS

- Overall Dimensions: 25.5"H x 20.5"W x 7"D
- Inlet connection: 3/4" FNPT
- Outlet connection: 3/4" FNPT
- Service Flow Rate: Maximum 5.0 gpm (18.9 Lpm) twin cartridges
- Pressure Requirements: 10 - 125 psi (0.7 – 8.6 bar), non-shock
- Maximum water temperature at inlet: 100°F (38°C)
- Alkalinity range: 2 to 12 grains per gallon
- No electrical connection required
- Operating Weight: 35 lbs.

Project \_\_\_\_\_

Item No. \_\_\_\_\_

Quantity \_\_\_\_\_

### BENEFITS

A total system delivering high quality filtered water with scale inhibition and deliming capabilities.

System filters incoming water to improve the performance, maximize energy efficiency, and increase the life of equipment.

The contaminants or other substances removed or reduced by this drinking water system are not necessarily in your water. Do not use with water that is microbiologically unsafe or of unknown quality without adequate disinfection before or after the system. Systems certified for cyst reduction may be used with disinfected water that may contain filterable cysts.

### OPERATIONS

- Change 7CB5 cartridge on a regular 6 month preventative maintenance program, when capacity is reached or when pressure falls below 10 psi.
- Change SS-10 cartridge before Hydroblend™ compound is completely used up.
- Service flow rate must not exceed 2.5 gpm for single cartridge systems or 5.0 for dual cartridge systems.
- Always flush the filter cartridge at time of installation and cartridge change.
- Use for periodic deliming as needed by installing the dip tube assembly in place of the SS-10 and dissolving Scale Kleen in SR-X housing. Full deliming instructions are provided with the system.

ScaleStick is NSF Certified under NSF/ANSI Standard 42 for materials.



System Tested and Certified by NSF International against NSF/ANSI Standard 42 for the reduction of:

Standard No. 42: Aesthetic Effects  
Chemical Unit  
Taste and Odor Reduction  
Chlorine Reduction

KLEENSTEAM II - TWIN CARTRIDGE



Pitco Frialator, Inc • P.O. Box 501, Concord, NH 03302-0501 • 509 Route 3A, Bow, NH 03304

603-225-6684 • FAX: 603-225-8497 • [www.pitco.com](http://www.pitco.com)

L10-574 Rev 0 5/13/2014 Printed in the USA

## KLEENSTEAM II – TWIN CARTRIDGE

## KLEENSTEAM II - TWIN CARTRIDGE

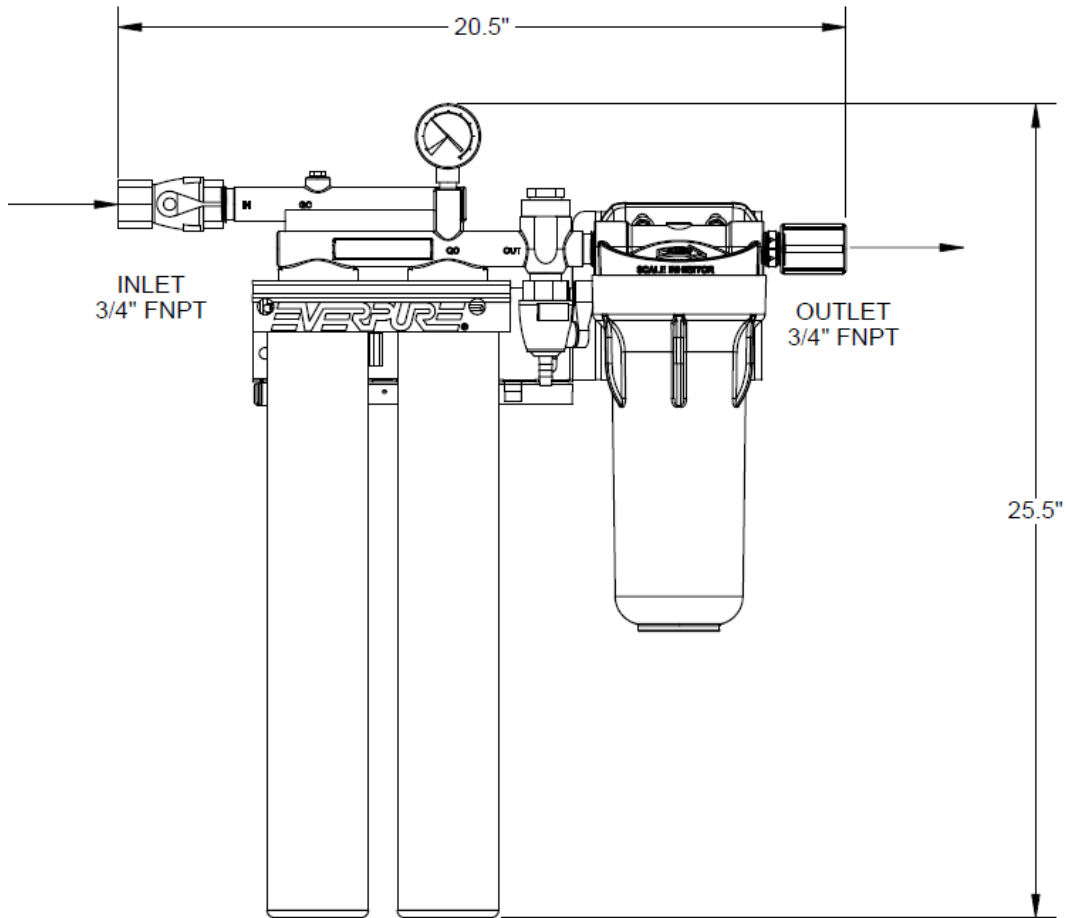

<b>KLEENSTEAM II TWIN SYSTEM</b>		
<b>PRESSURE REQUIREMENTS</b>	<b>MAX WATER TEMP</b>	<b>MAX FLOW</b>
10-125 psi (0.7-8.6 bar) Non-Shock	100°F (38°C)	3.5 gpm (13.2Lpm)
<b>SHIPPING INFORMATION (Approximate)</b>		
28 pounds (12.7 kg)		
<b>INLET/OUTLET SIZE</b>	<b>PERFORMANCE CHARACTERISTICS</b>	
3/4"FNPT & 3/4"FNPT	Removes contaminants from drinking water.	
<b>SHORT FORM SPECIFICATION</b>		
Provide KleenSteam II Twin System Water Filtration. Unit deliver high quality filtered water with scale inhibition and deliming capabilities. Reduces chlorine-induced corrosion. System improves performance, maximizes energy efficiency, and increases the life of equipment.		
<b>TYPICAL APPLICATION</b>		
Typical Application-Filtering inlet water to rethermalizers and pasta cookers.		



**Pitco Frialator, Inc** • P.O. Box 501, Concord, NH 03302-0501 • 509 Route 3A, Bow, NH 03304  
603-225-6684 • FAX: 603-225-8497 • [www.pitco.com](http://www.pitco.com)

L10-574 Rev 0 5/13/2014 Printed in the USA

We reserve the right to change specifications without notice and without incurring any obligation for equipment previously or subsequently sold.

AVAILABLE OPTIONS & ACCESSORIES



**E20 Coarse Prefilter w/Cartridge-60190801.**

Filters out larger contaminants and extends the life of the primary filters.

Tightly spun EC210 sediment cartridge delivers 10 micron nominal filtration.

Clear housing lets you visually inspect trapped particles and makes determining when to change the cartridge easy.



**7CB5 Filter Cartridge-60190901.**

Carbon block filter finely polishes water for high quality beverage and food applications.

Reduces chlorine taste and odor and other offensive contaminants that can adversely affect the taste of water and beverages.

Reduces extra fine dirt and particles as small as 5 microns in size.



**EC210 Coarse Prefilter Cartridge-60191101.**

Filters out larger contaminants and extends the life of the primary filters.

Tightly spun EC210 sediment cartridge delivers 10 micron nominal filtration.



**SS-10 ScaleStick-60191001.**

Features Hydroblend™ compound, a unique blend that inhibits mineral scale deposits and provides corrosion protection in low flow water-fed equipment.

Patented design (patent no. 5,580,448) dispenses a controlled amount of Hydroblend™ for long-term protection and provides greater effectiveness than standard phosphate treatments

Unaffected by high temperatures, permitting a wide variety of applications



**ScaleKleen Scale Remover (2.2lb)-60191201.**

Restores equipment to peak operating efficiency by removing scale build-up.

Non-toxic, safer to skin and won't burn clothing like conventional deliming acids.

Sewer system disposable, so you can pour it down the drain.

