



Project \_\_\_\_\_  
 Item No \_\_\_\_\_  
 Quantity \_\_\_\_\_

**MODEL CRTE Electric Countertop Rethermalizer**



Model CRTE Electric Countertop Rethermalizer

Standard Accessories

**CONSTRUCTION**

- Stainless steel cabinet.
- Marine grade 316 stainless steel tank.
- Quick disconnect drain fitting.
- Integrated drain screen to prevent clogging.
- CRTE Tank Dims: 12" x 18-1/2" x 8-1/2"

**CONTROLS**

- ON/OFF/RESET switch.
- Digital control with temperature display.
- Manual reset, high temperature protection. If the unit runs out of water and the tank overheats, the heating circuit is disabled until the ON/OFF/RESET switch is pressed to RESET.

**STANDARD ACCESSORIES**

- Display controller with temperature display
- Drain hose with shut off valve
- Four (4) product soup racks  
P/N# B4512001 (11" x 7-1/2" x 1-3/8")
- Stainless steel tank and cabinet
- Power cord supplied;
  - Shrouded twist lock (NEMA L6-30P)
  - Twist lock (NEMA L6-30P)
  - Pin and sleeve
  - 90° straight blade (NEMA 6-30P)
- 24 volt receptacle and mounting pins for product timer

Note: NCC product timer not supplied by Pitco

**OPERATIONS**

- Tank holds (6) gallons (22.7 liters) of water.
- Automatic temperature control.
- Rethermalizes prepared packaged foods.

**APPROVALS**

- NSF Listed (24100-0008-000)
- cUL Approved (E55456)
- UL Listed (E55456)



Optional Rack/ Basket Chart					
Part No.	Description	Inside Product Opening (W x H x D)	Qty Per Tank	Product Per Basket	Total Product Capacity
B4516101	Suitcase	11-3/8" x 10" x 2-1/2"	5	---	--
B4513501	Basket	11-1/4" x 7-3/4" x 2-1/2" (Tapered)	2	3	6
B4513401	Tank Screen (prevents bags from tearing when not in suitcase, basket or rack.)				



# Model CRTE Electric Countertop Rethermalizer

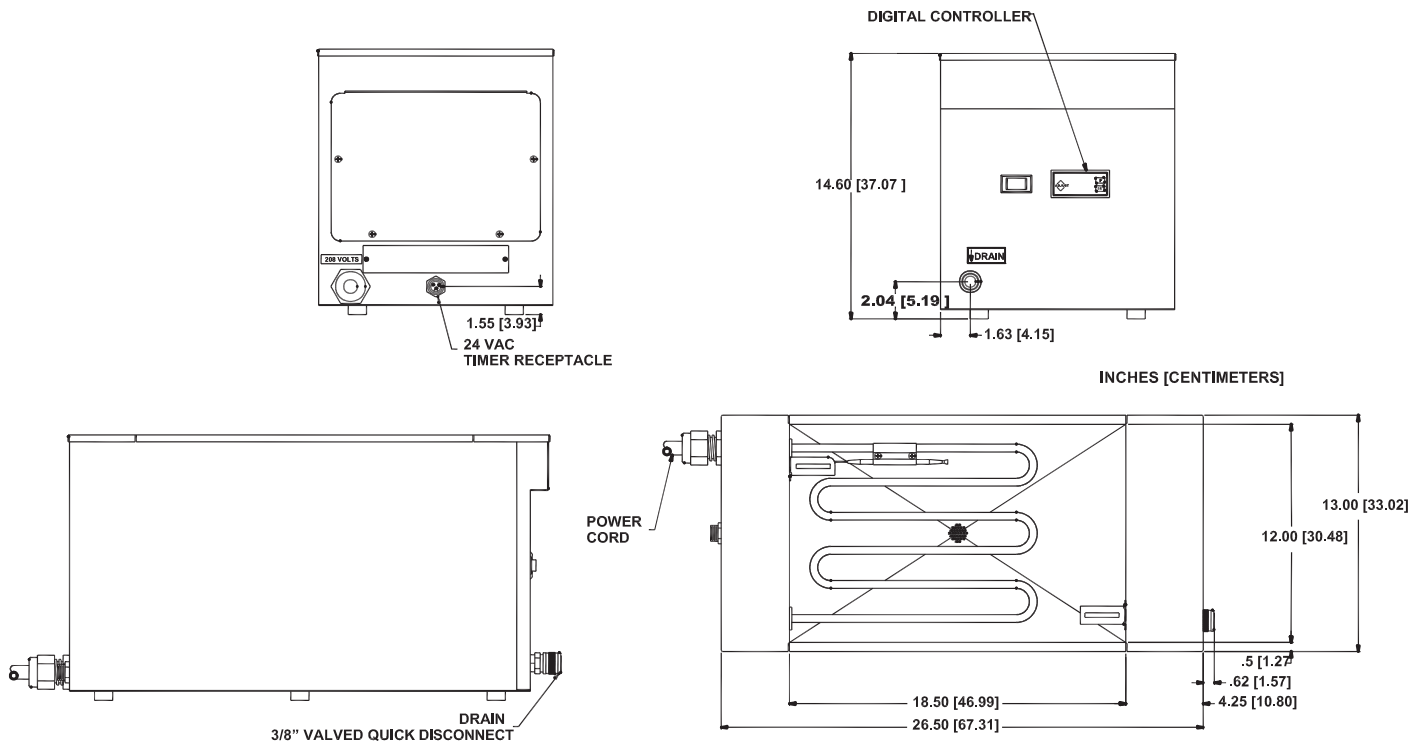

ELECTRIC COUNTERTOP RETHERMALIZER			
ELECTRIC		WATER CAPACITY	COOK DEPTH
Voltage/HZ/PHASE	AMPS/EA	6 Gallons (22.7 liters)	8 1/2" (22 cm)
208/60/1	29.8		
240/60/1	25		
SHIPPING INFORMATION (Approximate)			
60 pounds (27.2 kg)/6.3 cubic feet (0.18 cubic meters)			
ELECTRIC INPUT		PERFORMANCE CHARACTERISTICS	
6 kW		Rethermalizes prepared packaged food.	
SHORT FORM SPECIFICATIONS			
Provide Pitco Model CRTE Electric Countertop Rethermalizer. Unit shall have the ability to heat water and maintain thermostatically controlled temperature. Tank shall be constructed of type 316 stainless steel and hold 6 gallons (22.7 liters) of water with front drain. Entire cabinet shall be constructed of stainless steel. Provide accessories as follows:			
TYPICAL APPLICATION			
Typical Application-Rethermalizing pre-cooked/package food products.			

