



IMPORTANT FOR FUTURE REFERENCE

Please complete this information and retain this manual for the life of the equipment:

Model #: _____

Serial #: _____

Date Purchased: _____

ENGLISH

Installation & Operation Manual

Model SRTG

Floor Model Gas Rethermalizer

Built after 8/2005



TO THE PURCHASER, OWNER AND STORE MANAGER

Please review these warnings prior to posting them in a prominent location for reference.

TO THE PURCHASER

Post in a prominent location the instructions to be followed in the event that an operator smells gas. Obtain this information from your local gas supplier.

WARNING

DO NOT store or use gasoline or other flammable vapors and liquids in the vicinity of this or any other appliance.

WARNING

Improper installation, alteration, service or maintenance can cause property damage, injury or death. Read the installation, operating and maintenance instructions thoroughly before installing or servicing this appliance.

WARNING

Installation, maintenance and repairs should be performed by a Pitco Authorized Service and Parts (ASAP) company technician or other qualified personnel. Installation, maintenance or repairs by an unauthorized and unqualified personnel will void the warranty.

WARNING

Installation and all connections must be made according to national and local regulations and codes in force.

WARNING

During the warranty period if a customer elects to use a non-original part or modifies an original part purchased from Pitco and/or its Authorized Service and Parts (ASAP) companies, this warranty will be void. In addition, Pitco and its affiliates will not be liable for any claims, damages or expenses incurred by the customer which arises directly or indirectly, in whole or in part, due to the installation of any modified part and/or received from an unauthorized service center.

WARNING

This appliance, when installed, must be electrically grounded in accordance with local codes, or in the absence of local codes, with the National Electrical Code, ANSI/NFPA 70, or the Canadian Electrical Code, CSA C22.2, as applicable.

WARNING

Adequate means must be provided to LIMIT the movement of this appliance without depending on the gas or electrical cord connection. Single appliances equipped with legs must be stabilized by installing anchor straps. All appliances equipped with casters must be stabilized by installing restraining chains.

WARNING

An appliance equipped with casters and a flexible gas line must be connected to the gas supply with a quick disconnect device. This quick disconnect must comply with ANSI Z24.41.

WARNING

DO NOT alter or remove structural material on the appliance to accommodate placement under a ventilation hood.

WARNING

This appliance is intended for professional use only and should be operated by fully trained and qualified personnel.

WARNING

If the appliance is equipped with a power cord and it is damaged, it must be replaced by a Pitco Authorized Service and Parts (ASAP) company technician, or a similarly qualified person in order to avoid a hazard.

WARNING

The power supply must be disconnected before servicing, maintaining or cleaning this appliance.

WARNING

The appliance is NOT jet stream approved. DO NOT clean the appliance with a water jet.

WARNING

DO NOT attempt to move this appliance or transfer hot liquids from one container to another when the unit is at operating temperature or filled with hot liquids. Serious personal injury could result if skin comes in contact with the hot surfaces or liquids.

WARNING

DO NOT sit or stand on this appliance. The appliance's front panel, tank, splash back, tank cover, workshelf, drain board is not a step. Serious injury could result from slipping, falling or contact with hot liquids.

WARNING

NEVER use the appliance as a step for cleaning or accessing the ventilation hood. Serious injury could result from slips, trips or from contacting hot liquids.

WARNING

The water level should be maintained at the level line. DO NOT turn the appliance on until the heat tubes are fully covered with water at all times. Serious injury could result from hot steam vapors off the heat tubes.

WARNING

If overflow drain is not equipped or if overflow drain stop is used, do not leave appliance unattended while filling with water. Over filling the appliance can cause serious injuries and damage the equipment.

WARNING

Completely shut the appliance down when the water is being drained from the appliance. This will prevent the appliance from heating up during the draining and filling process. Serious injury can occur.

WARNING

This appliance is intended for indoor use only.

WARNING

DO NOT operate appliance unless all panels and access covers are attached correctly.

WARNING

It is recommended that this appliance be inspected by a qualified service technician for proper performance and operation on a yearly basis.

WARNING

There is an open flame inside this appliance. The unit may get hot enough to set nearby materials on fire. Keep the area around the appliance free from combustibles.

WARNING

DO NOT supply the appliance with a gas that is not indicated on the data plate. If you need to convert the appliance to another type of fuel, contact your dealer.

WARNING

DO NOT use an open flame to check for gas leaks!

WARNING

If gas flow to appliance is interrupted, or pilots extinguish, wait 5 minutes before attempting to relight the pilot to allow any residual gas in appliance to dissipate.

WARNING

Ensure that the appliance can get enough air to keep the flame burning correctly. If the flame is starved for air, it can give off a dangerous carbon monoxide gas. Carbon monoxide is a clear odorless gas that can cause suffocation.

1. INSTALLATION..... 1

1.1. CHECKING YOUR NEW APPLIANCE..... 1

1.2. INSTALLATION CLEARANCES 2

1.3. LEG/CASTER INSTALLATION AND LEVELING 2

1.4. PLUMBING CONNECTIONS..... 3

 1.4.1. WATER INLET CONNECTIONS..... 3

 1.4.2. DRAIN CONNECTIONS..... 3

1.5. GAS CONNECTION..... 4

 1.5.1. QUICK DISCONNECT CONNECTION..... 4

 1.5.2. FUEL SUPPLY LINE LEAK AND PRESSURE TESTING 4

 1.5.3. CE GAS TABLE..... 5

1.6. ELECTRICAL CONNECTIONS 7

1.7. VENTILATION AND FIRE SAFETY SYSTEMS 8

1.8. INSPECTION..... 9

1.9. INITIAL ADJUSTMENTS 10

 1.9.1. FILLING THE APPLIANCE 10

 1.9.2. LIGHTING INSTRUCTIONS 10

 1.9.3. PILOT FLAME ADJUSTMENT 11

 1.9.4. MAIN BURNER SYSTEM ADJUSTMENT 12

1.10. INITIAL CLEANING..... 13

2. OPERATION..... 14

2.1. FILLING THE APPLIANCE..... 16

 2.1.1. FILLING THE COOKER TANK 16

 2.1.2. FILLING THE COOKER TANK WITHOUT THE AUTOMATIC LEVEL SYSTEM..... 16

2.2. APPLIANCE START UP..... 17

2.3. COOKING..... 17

 2.3.1. SIMMER MODE 17

 2.3.2. BOIL MODE..... 17

TABLE OF CONTENTS



2.3.3.	TIMER OPERATION	17
2.3.4.	ADDITIONAL CONTROLLER FUNCTIONS	18
2.3.5.	COOKING TIPS.....	18
2.4.	APPLIANCE SHUTDOWN.....	18
2.4.1.	STANDBY MODE.....	18
2.4.2.	COMPLETE SHUTDOWN	18
3.	PREVENTATIVE MAINTENANCE	19
3.1.	DAILY PREVENTATIVE MAINTENANCE	19
3.1.1.	APPLIANCE INSPECTION	19
3.1.2.	CLEANING THE COOK TANK.....	19
3.1.3.	CLEANING THE CABINET	19
3.2.	MONTHLY PREVENTATIVE MAINTENANCE	19
3.2.1.	DELIMITING	20
3.3.	ANNUAL/PERIODIC PREVENTATIVE MAINTENANCE AND INSPECTION.....	20
3.3.1.	TEMPERATURE PROBE & HIGH LIMIT PROBE	20
3.3.2.	CONTROLLER.....	20
3.3.3.	CONTROL BOX & ELECTRICAL COMPONENTS.....	20
3.3.4.	TANK.....	20
3.3.5.	DRAIN SYSTEM	20
3.4.	VENTILATION HOOD.....	21
4.	TROUBLESHOOTING	22
4.1.	POWER FAILURE.....	22
4.2.	HIGH TEMPERATURE LIMIT	22
4.3.	DRAIN VALVE INTERLOCK	22
4.4.	TROUBLESHOOTING CHART	23
4.5.	CONTROLLER WARNING DISPLAYS.....	23

1. INSTALLATION

1.1. CHECKING YOUR NEW APPLIANCE

Your new Pitco appliance has been carefully packed into one crate. Every effort has been made to ensure that it is delivered to you in perfect condition. As you unpack your new appliance, inspect each of the pieces for damage. If something is damaged, **DO NOT** sign the bill of lading. Contact the shipper immediately; the shipper is only responsible for 15 days after delivery. Check the packing list enclosed with your appliance to ensure that you have received all the parts to the appliance. If you are missing any parts, contact the dealer from whom the appliance was purchased. As you unpack the appliance and its accessories be careful to keep the weight of the appliance evenly distributed. Refer to the table below to identify which accessories should be included with your appliance.

Locate your Pitco model number and serial number on the inner door of the appliance and the find the date purchased. Write this information on the front cover of this manual for future reference.

If you have completed the above steps that are applicable to the appliance you purchased, the appliance is now ready to be installed. Although it may be possible for you to install and set up your new appliance, it is **STRONGLY** recommended that you have this done by qualified professionals. A qualified professional will ensure that the installation is safe and meets local building and fire codes.

Accessories		
#	Description	SRTG
1	Cleaning brush	Standard
2	Tube Rack	Standard
3	8 Product Vertical Food Rack	Optional
4	8 Product Rack	Optional
5	6 Product Food Rack	Optional
6	Wide Product Suitcase	Optional
7	Narrow Product Suitcase	Optional
8	Tall Wide Product Suitcase	Optional
9	Tall Narrow Product Suitcase	Optional
10	Wide basket	Optional
11	Narrow Basket	Optional
12	8 Product basket	Optional
13	Gas Quick Disconnect & Lanyard	Optional
14	Water Quick Disconnect & Lanyard	Optional
15	1/3 Pan Rails	Optional

WARNING

DO NOT sit or stand on this appliance. The appliance's front panel, tank, splash back, tank cover, workshelf, drain board is not a step. Serious injury could result from slipping, falling or contact with hot liquids.

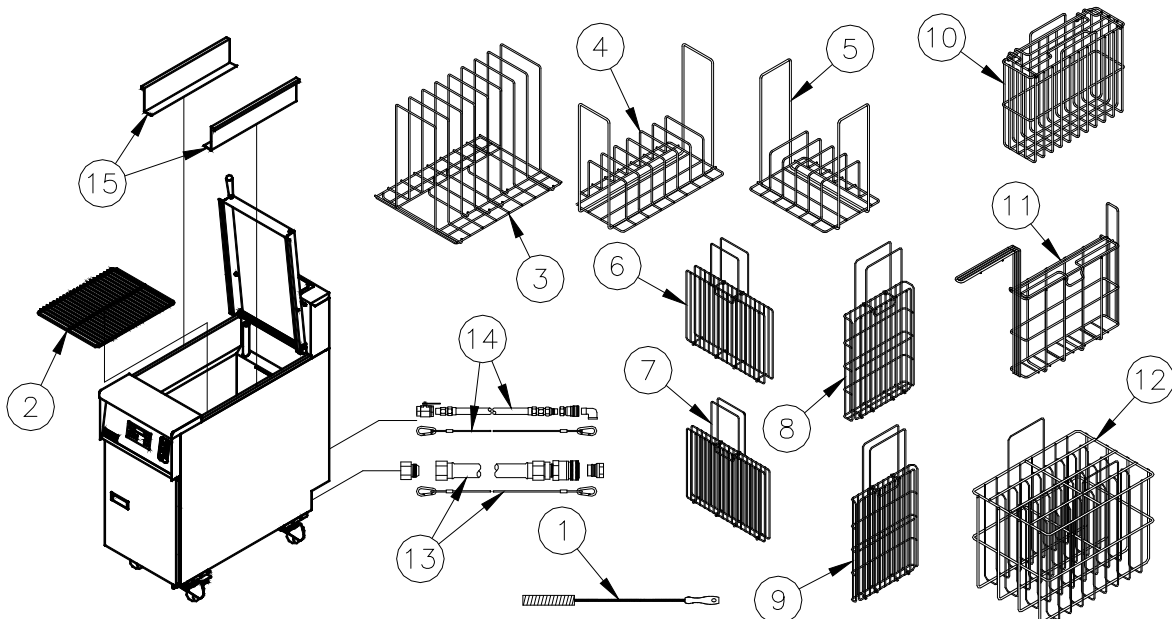

1.2. INSTALLATION CLEARANCES

The clearances shown below are for combustible and non-combustible installations and will allow for safe and proper operation of your appliance.

	Combustible Construction Inches (centimeters)	Non Combustible Construction Inches (centimeters)
Back	6.0" (15.24cm)	0.0" (0.0cm)
Sides	6.0" (15.24cm)	0.0" (0.0cm)
Floor	6.0" (15.24cm)	6.0" (15.24cm)

In addition to the above clearances there must also be at least 16 inches (40.64cm) of aisle space in front of the unit.

WARNING DO NOT obstruct the flow of ventilation, or air openings around the appliance. Adequate clearance around the appliance is necessary for servicing and proper component ventilation. Ensure that you meet the minimum clearance requirements specified in this manual.	WARNING DO NOT install this appliance next to a deep fat fryer. A splash over of water into the hot oil may cause a flash fire.
CAUTION To prevent equipment damage and/or personal injury, do not tilt the appliance onto any two of its casters or legs, or pull the appliance by the splash back.	WARNING This appliance <u>must</u> be installed with the legs or casters provided by the manufacturer.

1.3. LEG/CASTER INSTALLATION AND LEVELING

When you receive your appliance it is completely assembled with the possible exception of the legs (or casters). This appliance must be installed with legs or casters; it cannot be curb mounted. Curb mounting will seriously inhibit this appliance's ability to effect proper component ventilation. The legs/casters must be installed before connecting the appliance to the gas supply. The legs provide the necessary height to meet sanitation requirements and assure adequate air supply to the combustion system. Use the following procedure.

Required tools: 7/16 " wrench and socket and a large pair of water pump pliers.

1. Lay the appliance on its back, being careful not to damage the splash back by pulling on it. Protect the outside of the appliance with cardboard or a drop cloth when laying it down.
2. Attach each leg/caster with the hex head screws and nuts supplied. Each leg/caster requires four ¼-20 x 5/8" hex head screws and nuts. Insure that all screws are tight.
3. Mount the screws from the inside of the appliance with the nut on the outside (bottom) of the appliance. The nuts have lock washers attached to them, therefore it is not necessary to use separate lock washers.

WARNING DO NOT install legs or casters, or perform leveling procedure when appliance is in operation or full of hot liquids. Serious injury could result.

4. When all four legs/casters are securely mounted, stand the unit up, being careful not to put too much weight on any one leg. Adjust the height and level the appliance by adjusting the leveling devices (B) with water pump pliers. On casters, loosen 2 screws (A) before leveling, make your height adjustments, then retighten.

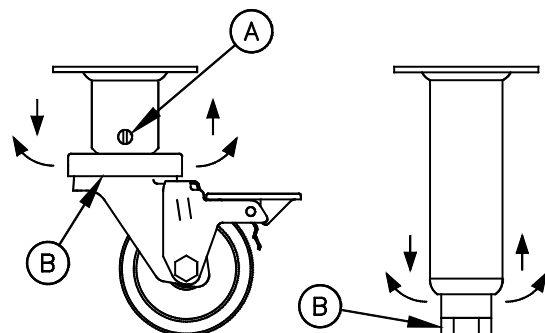

1.4. PLUMBING CONNECTIONS

The plumbing installation should be done by a licensed plumber and must comply with local and national codes.

1.4.1. WATER INLET CONNECTIONS

If a faucet or water fill option is equipped on your appliance connections to a potable water supply will be required. If a single water connection is required it is recommended that the appliance is connected to hot water supply. This will greatly decrease the time it takes for the appliance to reach operating temperature. Prior to installation, a water treatment specialist should inspect the water supply. Water hardness should contain no more than 2.0 grains/gallon. The pH level should be between 6.5 and 8.0. These conditions can be obtained with the use of a properly maintained water softener. The incoming water pressure should be between 20 psi (1.38 bars) to 60 psi (4.14 bars). For higher water pressures, a high-pressure regulator must be installed to inlet plumbing to avoid damage caused by water hammer. The maximum allowable incoming water temperature is 180°F (82°C). Have your water tested and record the measured values below.

Water Quality Checklist

	Measured	Range	OK
Temperature		180°F (82°C) Max.	
Hardness		2.0 Grains/Gal. Max.	
pH		6.5 to 8.0	
Pressure		20 psi to 60 psi	

WARNING
 When water is at a high temperature and high pressure, excessive splashing of hot water may occur that could result in injury.

1.4.2. DRAIN CONNECTIONS

Each tank has a drain that can be inserted into a drainage system. Each tank also has an overflow line. The overflow connection is after the drain valve to provide an unobstructed overflow path. The drain and overflow line for each tank is connected together to form a common drain line. Drain connections for this appliance will be either 1" female NPT or 1" male NPT.

WARNING
 Do NOT install a floor drain directly under the cabinet of the appliance. Steam from a floor drain can limit the life of internal components.

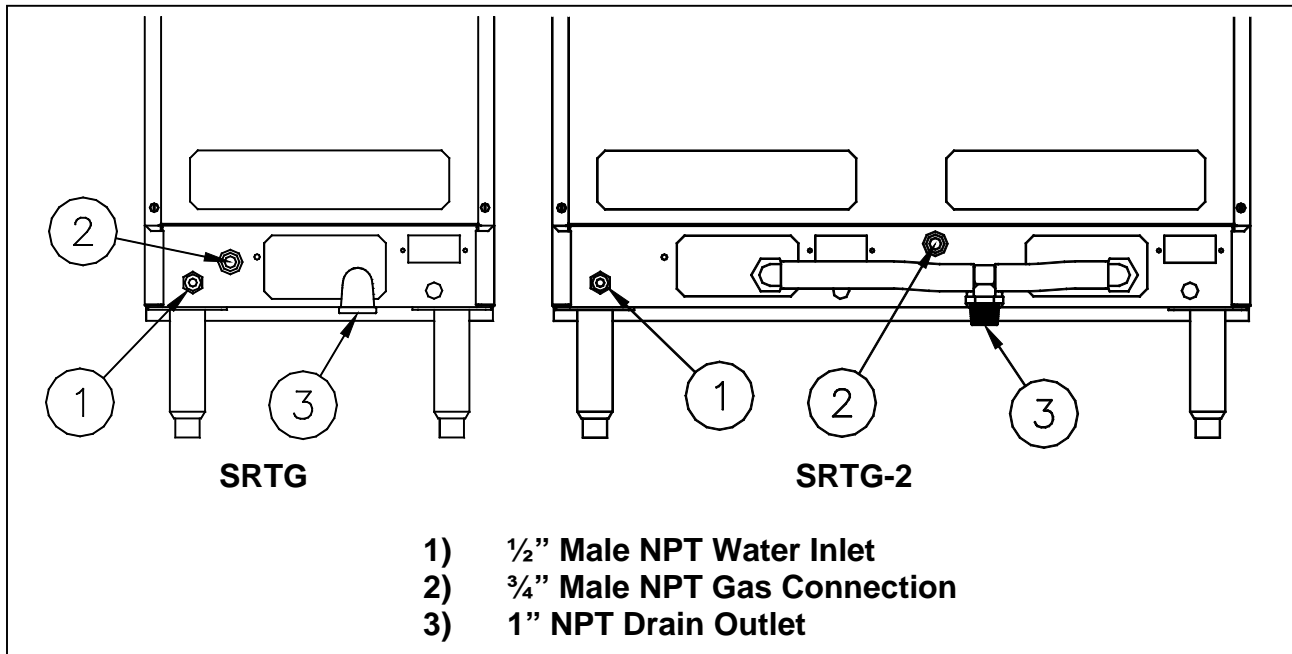

1.5. GAS CONNECTION

Your appliance will give you peak performance when the gas supply line is of sufficient size to provide the correct gas flow. The gas line must be installed to meet the local building codes or National Fuel Gas Code ANS Z223.1 and NFPA 54 (latest editions). In Canada, install the appliance in accordance with CSA B149.1 or .2 and local codes. Gas line sizing requirements can be determined by a qualified installation professional, your local gas company or by referring to the National Gas Fuel Code, Appendix C, Table C-4 (for natural gas) and Table C-16 (for propane). The gas line needs to be large enough to supply the necessary amount of fuel to all appliances without losing pressure to any appliance. A properly sized and installed gas line will deliver a supply pressure between 7.0" W.C. (17.4mbars, 1.74kPa) and 10.0"W.C. (24.9mbars, 2.49kPa) natural gas or between 11.0"W.C. (27.4mbars, 2.74kPa) and 13.0" W.C. (32.4mbars, 3.25kPa) propane to all appliances connected to the supply line, operating simultaneously at full demand. The pressure at the gas valve shall not exceed ½ PSI.

Each appliance is equipped to operate on one certain fuel type. The type of fuel with which the appliance is intended to operate is stamped on the data plate, which is attached to the inside of the door.

WARNING

NEVER supply the appliance with a gas other than the one that is indicated on the data plate. Using the incorrect gas type will cause improper operation and could result in serious injury or death. If you need to convert the appliance to another type of fuel, contact the dealer you purchased it from.

NOTICE

NEVER use an adapter to make a smaller gas supply line fit the appliance connection. This may not allow proper gas flow for optimum burner operation, resulting in poor performance and improper operation.

1.5.1. QUICK DISCONNECT CONNECTION

Gas appliances equipped with casters must be installed with connectors that comply with the Standard for Movable Gas Appliances, ANSI Z21.69 • CSA 6.16 latest edition. This connection should include a quick disconnect device that complies with the Standard for Quick Disconnect Devices for Use With Gas Fuel, ANSI Z21.41 • CSA 6.9 latest edition. When installing a quick disconnect you must also install adequate means for limiting the movement of the appliance without depending on the connector and quick-disconnect device or it's associated piping to limit the movement of the appliance. The restraining device should be attached to the appliance on the back panel.

1.5.2. FUEL SUPPLY LINE LEAK AND PRESSURE TESTING

The fuel supply system must be tested before the appliance is used. If the fuel line is going to be tested at a pressure greater than ½ PISG (3.45 kPa), insure that that appliance is disconnected from the fuel line. If the fuel line is to be tested at a pressure equal to or less than ½ PSIG (3.45 kPa), the appliance can be connected during the test, but the unit's gas valve must be shut. Test all gas line connections for leaks with a solution of soap and water when pressure is applied.

1.5.3. CE GAS TABLE

Refer to the following table for gas specifications for the country of use. If the country of use is NOT listed, refer to the information stamped on the data plate.

Country	Gas	Appliance Category	Input Gross (kW)	Input Net (kW)	Supply Pressure (mbar)	Burner Pressure (mbar)	Burner Orifice	Pilot Orifice	Governor	Nom rate (M3/HR)
AT	G20	I2H	16	14.4	20	10	#42	N22	YES	1.5
	G31	I3P		14.7	50	25.4	#53	LP16	YES	0.6
BE	G20/G25	I2E+	16	14.4	20/25	10	#42/2.58 mm	N22	NO	1.5
	G31	I3P		14.7	37	25.4	#53	LP16	YES	0.6
BG	G20	I2H	16	14.4	20	10	#42	N22	YES	1.5
	G31	I3P		14.7	50/37	25.4	#53	LP16	YES	0.6
CH	G20	I2H	16	14.4	20	10	#42	N22	YES	1.5
	G31	I3P		14.7	50/37	25.4	#53	LP16	YES	0.6
CY	N/A	N/A	16	N/A	N/A	N/A	N/A	N/A	N/A	N/A
	G31	I3P		14.7	50	25.4	#53	LP16	YES	0.6
CZ	G20	I2H	16	14.4	20	10	#42	N22	YES	1.5
	G31	I3P		14.7	50/37	25.4	#53	LP16	YES	0.6
DE	G20/G25	I2ELL	16	14.4	20/25	10	#42/2.58 mm	N22/MF28	YES	1.5/1.8
	G31	I3P		14.7	50/37	25.4	#53	LP16	YES	0.6
DK	G20	I2H	16	14.4	20	10	#42	N22	YES	1.5
	N/A	N/A		N/A	N/A	N/A	N/A	N/A	N/A	N/A
EE	G20	I2H	16	14.4	20	10	#42	N22	YES	1.5
	N/A	N/A		N/A	N/A	N/A	N/A	N/A	N/A	N/A
ES	G20	I2H	16	14.4	20	10	#42	N22	YES	1.5
	G31	I3P		14.7	50/37	25.4	#53	LP16	YES	0.6
FI	G20	I2H	16	14.4	20	10	#42	N22	YES	1.5
	N/A	N/A		N/A	N/A	N/A	N/A	N/A	N/A	N/A
FR	G20/G25	I2Esi	16	14.4	20/25	10	#42/2.58 mm	N22/MF28	YES	1.5/1.8
	G31	I3P		14.7	50/37	25.4	#53	LP16	YES	0.6
GB	G20	I2H	16	14.4	20	10	#42	N22	YES	1.5
	G31	I3P		14.7	50/37	25.4	#53	LP16	YES	0.6
GR	G20	I2H	16	14.4	20	10	#42	N22	YES	1.5
	N/A	N/A		N/A	N/A	N/A	N/A	N/A	N/A	N/A
HU	G20	I2H	16	14.4	20	10	#42	N22	YES	1.5
	G25.1	I2S		14.4	25	10	#36	N22/MF28	YES	1.8
	G31	I3P		14.7	50	25.4	#53	LP16	YES	0.6

INSTALLATION



CE Gas table Continued

Country	Gas	Appliance Category	Input Gross (kW)	Input Net (kW)	Supply Pressure (mbar)	Burner Pressure (mbar)	Burner Orifice	Pilot Orifice	Governor	Nom rate (M3/HR)
IE	G20	I2H	16	14.4	20	10	#42	N22	YES	1.5
	G31	I3P		14.7	50/37	25.4	#53	LP16	YES	0.6
IS	G20	I2H	16	14.4	20	10	#42	N22	YES	1.5
	N/A	N/A		N/A	N/A	N/A	N/A	N/A	N/A	N/A
IT	G20	I2H	16	14.4	20	10	#42	N22	YES	1.5
	G31	I3P		14.7	37	25.4	#53	LP16	YES	0.6
LT	G20	I2H	16	14.4	20	10	#42	N22	YES	1.5
	N/A	N/A		N/A	N/A	N/A	N/A	N/A	N/A	N/A
LU	G20	I2E	16	14.4	20	10	#42	N22	YES	1.5
	G31	I3P		14.7	50/37	25.4	#53	LP16	YES	0.6
LV	G20	I2H	16	14.4	20	10	#42	N22	YES	1.5
	N/A	N/A		N/A	N/A	N/A	N/A	N/A	N/A	N/A
MT	N/A	N/A	16	N/A	N/A	N/A	N/A	N/A	N/A	N/A
	G31	I3P		14.7	50	25.4	#53	LP16	YES	0.6
NL	G25	I2L	16	14.4	25	10	2.58 mm	N22/MF28	YES	1.8
	G31	I3P		14.7	50	25.4	#53	LP16	YES	0.6
NO	G20	I2H	16	14.4	20	10	#42	N22	YES	1.5
	N/A	N/A		N/A	N/A	N/A	N/A	N/A	N/A	N/A
PL	G20	I2H	16	14.4	20	10	#42	N22	YES	1.5
	G31	I3P		14.7	37	25.4	#53	LP16	YES	0.6
PT	G20	I2H	16	14.4	20	10	#42	N22	YES	1.5
	G31	I3P		14.7	37	25.4	#53	LP16	YES	0.6
RO	G20	I2H	16	14.4	20	10	#42	N22	YES	1.5
	G31	I3P		14.7	50/37	25.4	#53	LP16	YES	0.6
SE	G20	I2H	16	14.4	20	10	#42	N22	YES	1.5
	N/A	N/A		N/A	N/A	N/A	N/A	N/A	N/A	N/A
SI	G20	I2H	16	14.4	20	10	#42	N22	YES	1.5
	G31	I3P		14.7	37	25.4	#53	LP16	YES	0.6
TR	G20	I2H	16	14.4	20	10	#42	N22	YES	1.5
	G31	I3P		14.7	50/37	25.4	#53	LP16	YES	0.6

1.6. ELECTRICAL CONNECTIONS

It is advised that this power supply be plugged into a wall receptacle that is controlled by the ventilation control. This will prevent the appliance from being operated without the ventilator on. If your appliance requires an electrical connection, the power requirements are listed below.

	North America	International
Input Voltage	120 VAC, 50/60 Hz	220, 230 or 240 VAC 50/60 Hz
Current per unit	1.0 Amp	0.5 Amps

CAUTION
Connecting the appliance to the wrong power supply may damage the appliance and void the warranty.
WARNING
This appliance must be connected to a power supply having the same voltage and phase as specified on the data plate located on the inside of the appliance door.
WARNING
DO NOT attempt to connect the appliance to an electrical supply other than that indicated on the data plate. Electrical connection should be performed by qualified personnel.
WARNING
The electrical connection used by this appliance must comply with local codes. If there are no local codes that apply, refer to the National Electrical Code (NEC), ANSI/NFPA 70 for installation in the US. In Canada, refer to CSA Standard C22.2 and local codes. In all other cases, refer to local and national codes and regulations.
WARNING
The appliance must be grounded in accordance with local code; if there is no local code, comply with the NEC and ANSI/NFPA No. 70 latest edition (for US and Canadian installations). In all other cases, refer to local and national codes and regulations. To comply with European requirements, European models are equipped with an equalization-bonding clamp. An equalization bonding lead must be connected to this clamp to provide sufficient protection against potential difference. This clamp, located on the rear of the appliance is marked with the following universal symbol. 
WARNING
A country approved all pole circuit breaker with a minimum open contact gap of 3mm must be used for proper installation. (CE countries)
WARNING
This equipment must be installed so that the plug is accessible unless other means for disconnection from the power supply (e.g. a circuit breaker) is provided.
WARNING
If this appliance is permanently connected to fixed wiring, it must be connected by means of copper wires having a temperature rating of not less than 167°F (75°C).
WARNING
All copper wiring for this appliance must be made in accordance with the wiring diagram(s) located on the appliance.

WARNING

If your appliance is uses line current, it is equipped with an oil proof, electrical supply cord with a three-prong safety plug. This is to protect operators from electrical shock hazard in the event of an equipment malfunction. **DO NOT** cut or remove the grounding (third) prong from this plug; it should be plugged into a properly grounded three-prong receptacle.

1.7. VENTILATION AND FIRE SAFETY SYSTEMS

Your new appliance must have proper ventilation to function safely and properly. Exhaust gas temperatures can reach as high as 1100 °F (593 °C). Therefore, it is very important to install a fire safety system. Your ventilation system should be designed to allow for easy cleaning. Frequent cleaning and proper maintenance of the ventilation system and the appliance will reduce the chances of fire. Ventilation and fire safety systems must comply to local and national codes. Refer to ANSI 83.11 for a list of reference documents that will provide guidance on ventilation and fire safety systems. For installations in U.S. and Canada, additional information can be obtained from CSA International, 8501 East Pleasant Valley Road, Cleveland, OH, 44131 or visit their website at www.csa-international.org.

It is essential that the appliance be operated only when adequate ventilation is provided. Your ventilation hood should be properly maintained. A qualified installation professional should ensure that the hood is operating properly in conjunction with the appliance. Inadequate ventilation may not properly evacuate appliance all emissions. Excessive or unbalanced ventilation may cause drafts, which could interfere with proper operation of the pilot and burners. Leave at least 18 inches (45.72cm) of open space between the flue of the appliance and the intake of the exhaust hood.

WARNING

Ensure that your ventilation system does not cause a down draft at the appliance's flue opening. A down draft will not allow the appliance to exhaust properly and will cause overheating, which may cause permanent damage. Damage caused by down drafts will not be covered by the warranty. **NEVER** allow anything to obstruct the flow of combustibles or ventilation exiting the appliance. **NEVER** place anything on top of the flue area, or block the flue in any way. Never place a hood grease condensating drip pan over the flue opening.

WARNING

NEVER connect the ventilation blower or hood directly to the flue of this appliance. The resulting increased flow of air through the combustion system will cause improper operation, poor temperature recovery, poor ignition and could extinguish the pilot.

1.8. INSPECTION

Before you begin filling and adjusting the appliance, perform the following visual checks:

- ✓ After the appliance is in its permanent location, check the levelness. Any additional leveling that is necessary can be performed as previously described.
- ✓ Ensure that the probe, and high temperature limit is in place and secure. Check the high limit bulb mounting screws to ensure that they are tight.
- ✓ Review the installation portion of this manual and ensure that all steps have been followed and executed properly.

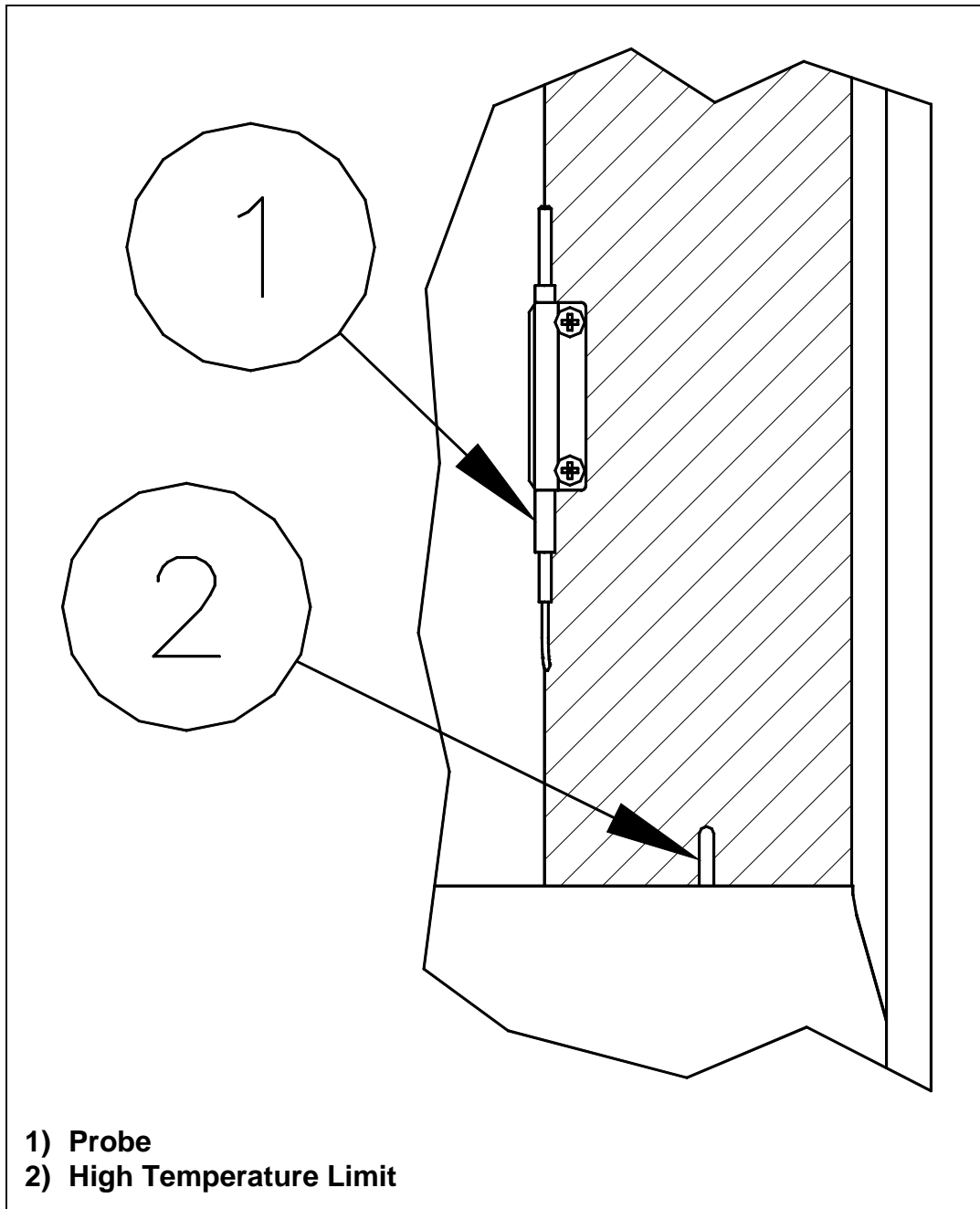

1.9. INITIAL ADJUSTMENTS

After your appliance has been properly installed as described in the installation section of this manual, it will need to be adjusted to ensure that it will perform as designed. A qualified person must perform these adjustments.

To perform these adjustments the following tools will be needed:

- Manometer
- Digital Thermometer (Temperature Probe)
- DC Microammeter

1.9.1. FILLING THE APPLIANCE

Refer to the following procedure to fill the cook tank prior to operation.

1. Ensure that the drain valve is closed.
2. This appliance is equipped with an automatic water level maintaining system. To fill the tank with water, turn the unit's ON/OFF switch to the ON position. This will cause the tank to fill with water. The tank will continue to fill until the water level reaches the level sensors.

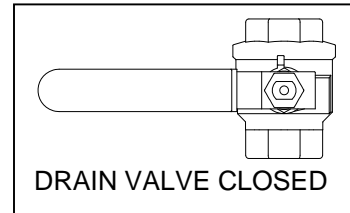

WARNING

Water must completely cover the heat tubes at all times while appliance is on.

CAUTION

This appliance is not designed for cooking with oil. Fill with potable water only.

WARNING

During operation there is an open flame inside this appliance. The unit may get hot enough to set near by materials on fire. Keep the area around the appliance free from combustibles.

1.9.2. LIGHTING INSTRUCTIONS

There is nothing to manually light on the electronic ignition system. Pilot ignition is performed and controlled by the electronic ignition system. Refer to the following instructions to light the appliance.

1. Open the gas supply valves to the appliance.
2. Turn the gas valve knob to the ON position.
3. If the appliance is equipped with a I/O (ON/OFF) switch, turn it to the I (ON) position.
4. If the appliance is equipped with a controller it may need to be turned on. Refer to the operator's manual for your appliance's specific control type to determine how to do this.
5. When the water reaches the correct operating level, the main burners will light and be controlled by the thermostat.

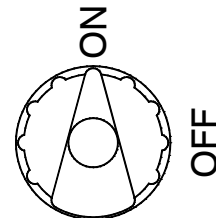

1.9.3. PILOT FLAME ADJUSTMENT

Perform this procedure with the pilot lit.

Note: This procedure requires the use of a DC microammeter.

1. Connect the DC microammeter between the flame sensor terminal and the flame sensor lead. Observe proper polarity: if the meter needle goes below 0, reverse the leads. The current reading must be 1.0 μA or greater, (0.15 μA or greater for CE units).
2. Adjust the current reading to the required level by adjusting the pilot flame. Remove the pilot adjustment screw cap screw to expose the pilot adjustment screw. Turning the pilot adjustment screw clockwise will decrease the size of the pilot flame and flame sense current. Turning the pilot adjustment screw counterclockwise will increase the pilot flame size and the flame sense current.
3. Rotate the screw in the direction needed to achieve a reading of 1.0 μA or greater, (0.15 μA or greater for CE units).

Note: Allow 3 to 5 minutes between flame adjustments to allow the reading to stabilize.

4. Once the pilot flame has been adjusted properly, replace the pilot adjustment screw cap screw and remove the microammeter.

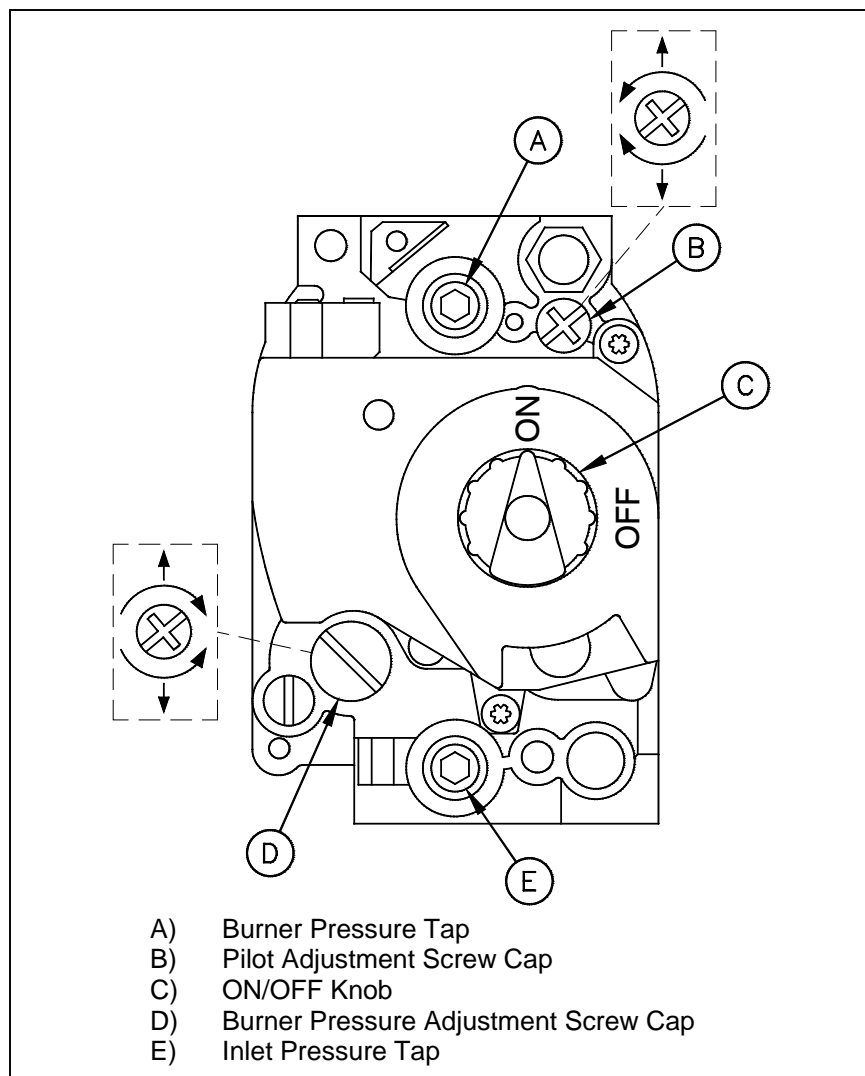

1.9.4. MAIN BURNER SYSTEM ADJUSTMENT

For the main burners to operate the gas supply valve must be open and the thermostat must be turned on. The main power switch must be on. The main burners receive gas from the main gas supply through the thermostatically controlled valve. When the water temperature drops below the preset temperature the gas control valve opens.

The main burners must be adjusted to deliver optimum flame. Refer to the following procedure to adjust the main burners.

1. Ensure that the main gas valve is shut off, remove the manifold pressure tap plug and connect an accurate pressure gauge (range of 0-16 "W.C. (39.85mbar, 3.98kPa) in 0.1" (.25mbar, .02kPa) increments) or manometer.
2. Turn on this and all appliances connected to the gas supply line and light their main burners. The pressure reading of the installed pressure gauge should not drop from the required installation pressure. Any loss of pressure indicates inadequate supply line installation, which will cause poor performance of all appliances during peak usage.
3. The installed pressure gauge should be the same, ± 0.1 " W.C. (.25mbar, .02kPa), as that marked on the data plate on the inside door of the appliance. If the pressure is correct, go to step 6, if it is not, adjust the pressure as outlined in step 4.
4. To adjust the pressure, remove the regulator adjustment screw cap and, with a flat head screwdriver, adjust the regulator screw until the proper burner pressure is reached. Turning the screw clockwise will increase the burner pressure. Turning the screw counterclockwise will decrease the burner pressure.
5. When the pressure is correct, replace the regulator adjustment screw cover.
6. Turn off the ALL appliances, shut the main gas valve to your Pitco appliance and remove the pressure gauge. Apply pipe joint compound to the manifold pressure tap plug and reinstall it.

CAUTION

Be careful not to disturb the probe and high temperature limit during operation and cleaning of this appliance.

1.10. INITIAL CLEANING

When your appliance is shipped, many of its parts are covered with a thin coat of oil for protection. Before the appliance is ready for cooking it must be cleaned. This will remove the oil coating and any foreign matter that may have accumulated during storage and shipment. Refer to the following procedure to clean the appliance.

WARNING

Wear protective gloves and clothing when cleaning and draining the appliance and when disposing of water. The water is extremely hot and can cause severe injuries.

CAUTION

DO NOT leave the appliance unattended during cleaning. Never let the water level go below the heat tubes.

1. Read the "operation" section of this manual prior to filling or operating the appliance.
2. The following steps should be followed using a grease dissolving commercial cleaner.

WARNING

Use a commercial grade cleaner formulated to effectively clean and sanitize food contact surfaces. Read the directions and precautionary statements before use. Particular attention must be paid to the concentration of cleaner and the length of time the cleaner remains on the food contact surfaces.

3. Following the manufacturer's directions, clean the tank interior and all other food contact surfaces.
4. When cleaning is complete, rinse the inside of the tank thoroughly with cool water. Continue to rinse the tank until the cleaner has been completely and thoroughly rinsed from the tank.
5. Using a clean dry cloth, wipe out all of the water.

2. OPERATION

An operator's manual for your appliance's specific control type should be included with this manual. Refer to that manual prior to operating this appliance.

2.1. OPERATIONAL FEATURES

The diagram below outlines some of the key operational components of your appliance. Refer to the following sections of this manual to learn more about these features.

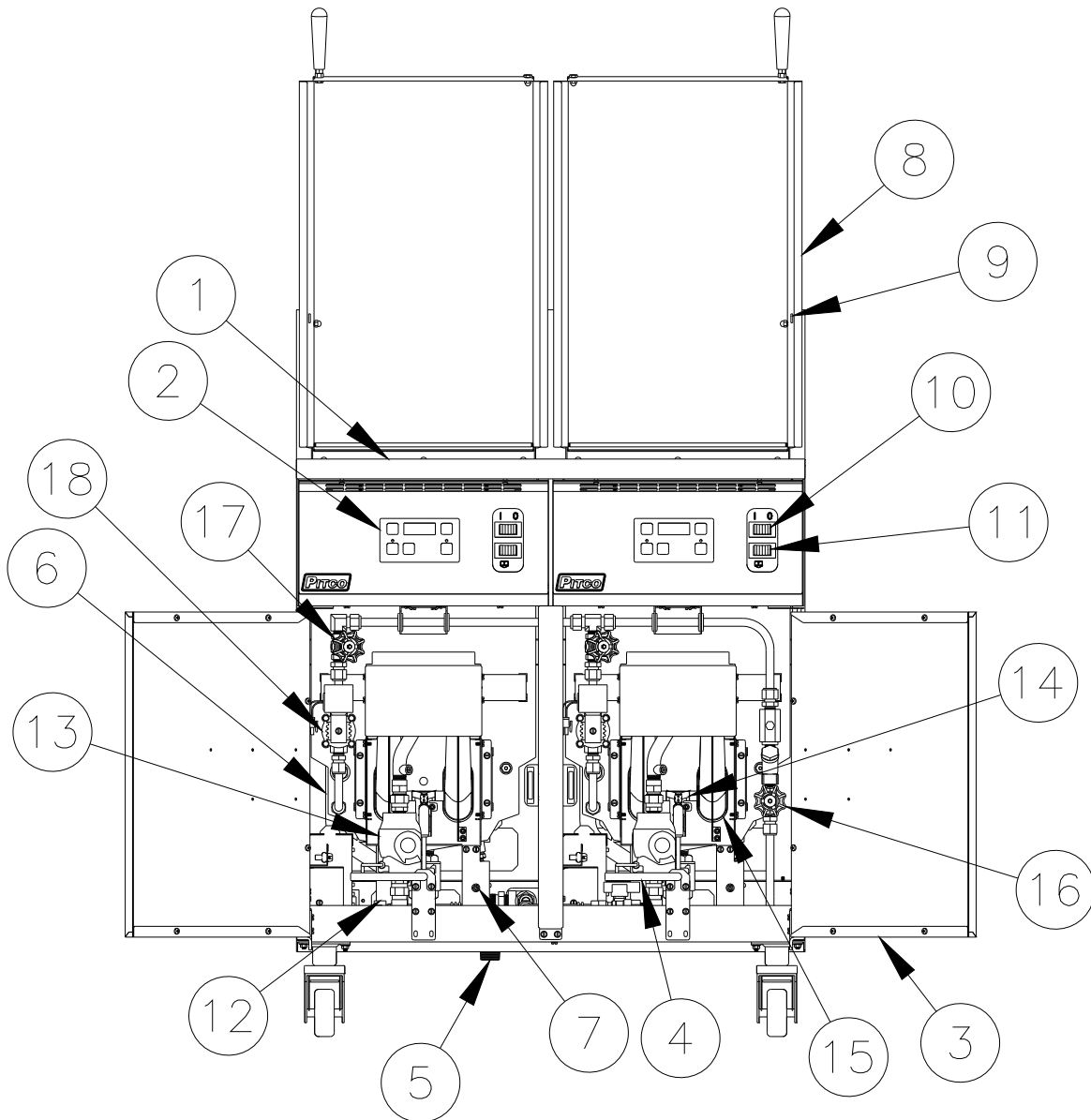

1. **Cook Tank**
2. **Controller (*Not on all Models*)**
Controls the water temperature inside the cook tank.
Optional timers are located on the controller (if equipped).
If the controller has an ON/OFF button, it will be used to turn ON the controller as well as other features on the appliance.
3. **Door (*Shown Open*)**
Provides access to the drain valve handle, high temperature reset button and gas valve, pilot, burners and shutoff valves.
4. **Drain Valve Handle (*Shown in the closed position*)**
Opens the drain valve so water can be drained from the cook tank.
The drain valve interlock feature will stop the appliance from heating if the drain valve is opened.
5. **Drain Outlet**
Water exits the cook tank through the drain outlet when draining or overflowing.
6. **Overflow Line**
When the cook tank water level reaches the overflow, water will flow unobstructed through the overflow line and eventually exit the appliance through the drain outlet.
7. **High Temperature Reset Button**
This button may need to be pressed in the event that the high temperature limit has tripped.
8. **Tank Cover (*shown in UP position*)**
Keeps heat inside and debris outside of the cook tank.
9. **Tank Cover Latch**
Holds the tank cover in the up position when adding or removing product from the cook tank.
10. **ON/OFF Switch**
Turns the appliance ON and OFF. Some controllers require that they are turned ON by another button after the ON/OFF switch is in the ON position.
11. **Fill Bypass Switch**
When this switch is held down the cook tank will fill with water regardless of the water level.
12. **Gas Shutoff Valve**
Shuts off the supply of gas to the gas valve.
13. **Gas Valve**
Controls the flow of gas to the pilot and burners.
14. **Pilot**
The pilot lights the burners when the water in the cook tank requires more heat.
15. **Burners**
Heats the water inside the cook tank.
16. **Main Water Shutoff Valve**
Shuts off the water supply to all tanks inside the cabinet.
17. **Tank Water Shutoff Valve**
Shuts off the water supply to the closest tank.
18. **Solenoid Water Valve**
Turns the supply of water to the tank ON and OFF.
This valve is controlled by the water level sensors inside the tank.
Valve can also be controlled by the fill bypass switch.

2.2. FILLING THE APPLIANCE

2.2.1. FILLING THE COOKER TANK

It is recommended that the cooker tank is filled with hot water. This will greatly decrease the time it takes for the appliance to reach operating temperature. Refer to the following procedure to fill the cook tank prior to operation.

CAUTION
This appliance is not designed for cooking with oil. Fill with potable water only.

Tank Capacity	
Model	Capacity
SRTG	17-1/2 Gal. (66.2 Liters)

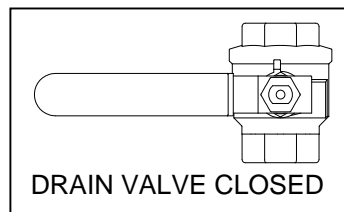

1. Ensure that the drain valve is closed.
2. Fill the tank with water until the water reaches the water level line(s).
3. This appliance is equipped with an automatic water level maintaining system. To fill the tank with water, Press the unit's I/O (ON/OFF) switch to the I (ON) position. This will cause the tank to fill with water. The tank will continue to fill until the water level reaches the level sensors. When both of the active water level sensors are covered the solenoid valve will close stopping the flow of water. During normal operation the automatic fill system will maintain the water level at the proper height.

NOTE: If the water control system turns on while the main burners are running, the main burners will turn off. This is Normal and will not affect the operation of the appliance. When the tank refills to the high level probe, the main burners will relight.

2.2.2. FILLING THE COOKER TANK WITHOUT THE AUTOMATIC LEVEL SYSTEM

Although the water fill system is completely automatic, the tank can be filled without putting the appliance into full operational mode. To fill the tank without operating the appliance press the rocker switch to the symbol. Continue to hold down the switch until the appliance is completely filled.

WARNING
Water must completely cover the heat tubes at all times while appliance is on.

2.3. APPLIANCE START UP

Refer to the following procedure to start the appliance prior to operation.

1. Ensure that the drain valve is closed.
2. Fill the cook tank with water. (See section 2.1 “Filling the Appliance”)
3. Light the appliance. (See section 1.8.2 “Lighting Instructions”)
4. Turn the I/O (ON/OFF) switch, to the I (ON) position.

WARNING

NEVER operate the appliance with an empty cook tank. It may void the warranty. Adding water after the heat tubes have been heated may cause injuries from hot splattering liquids and steam.

5. The appliance's controller may need to be turned on. Press the * button to turn the controller on.

**The specified button may appear slightly different then shown. Refer to the operator's manual for your appliance's specific control type to determine the exact appearance of each button and display.*

6. The appliance is now on and heating the water in the cook tank.

WARNING

Water must completely cover the heat tubes at all times while appliance is on.

2.4. COOKING

It is important to keep the cook tank full of water to minimize the chance of boiling the appliance dry and to keep the water at a level that will provide optimum cooking performance. To ensure the quality of the food you cook in this appliance, follow the preparation instructions from the food manufacturer.

WARNING

Dry fired heat tubes are extremely hot, will shorten its service life and may void your warranty.

Maximum Recommended Product Capacity (after 195°F preheat)
2160 in³ Total (12x 180 in³ bags or equivalent) per tank

2.4.1. SIMMER MODE

Simmer mode maintains the water temperature to just below boiling. This mode is used to reheat food or as a “stand by” mode. When the appliance is turned on, it will be in simmer mode.

2.4.2. BOIL MODE

Boil mode consistently heats the water so that the water will boil. Use of this mode is not recommended for your appliance. Not all control types include boil mode.

2.4.3. TIMER OPERATION

Not all control types include timers. Timers provide accurate cook times for multiple product quantities and types. Refer to the operator's manual for your appliance's specific control type to determine how to set the cook timers if equipped.

To start a timer: Press the appropriate timer button.

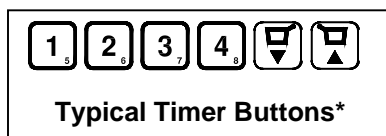

***Timer buttons may appear slightly different then shown. Refer to the operator's manual for your appliance's specific control type to determine the exact appearance of each timer button.**

2.4.4. ADDITIONAL CONTROLLER FUNCTIONS

Some controllers have additional functions not described in this manual. If your appliance's controller has additional functions, refer to the controller's operation manual to access these functions.

2.4.5. COOKING TIPS

- ✓ Always follow the food manufacturer's directions and only use vacuum-sealed products in this appliance.
- ✓ Some products can be reheated and held at the same temperature. If this is the case, the product may be held in this appliance while still in its vacuum-sealed bag. No separate holding device required.
- ✓ Product bag size can be important in reaching the shortest retherm times. Thin bags typically retherm faster than thicker ones.
- ✓ Always allow a gap between product bags. This will allow the hot water to circulate around the entire surface of the product bag, creating good heat transfer and ultimately shorter retherm times.
- ✓ Do NOT retherm in boiling water. Boiling water increases your energy and water consumption and furthermore this appliance is NOT recommended for boiling.
- ✓ Always follow proper food safety. Refer to FDA and the food manufacturer's guidelines for proper handling of the vacuum-sealed product.

Typical Retherm Times		
Product	Appliance Temperature	
	140F	200F
Frozen	40 min.	9-10 min.
Thawed	30 min.	7-8 min.

This table is for reference only. Please refer to the product manufacturer's specifications to determine exact cook times.

2.5. APPLIANCE SHUTDOWN

There are two shutdown modes of appliance operation: STANDBY and COMPLETE. The standby mode removes the ability of the appliances main burners to operate. Complete shutdown turns off the gas supply to the appliance. Refer to the following procedures to enter the appropriate shutdown mode.

2.5.1. STANDBY MODE

1. If the appliance is equipped with a controller it should be turned OFF. If the controller has an ON/OFF button, press and hold the button until the controller is off.
2. If the appliance is equipped with a I/O (ON/OFF) switch, turn it to the 0 (OFF) position.

WARNING
NEVER leave the appliance in standby mode for prolonged periods or overnight.

2.5.2. COMPLETE SHUTDOWN

1. If the appliance is equipped with a controller it should be turned OFF. If the controller has an ON/OFF button, press and hold the button until the controller is off.
2. If the appliance is equipped with a I/O (ON/OFF) switch, turn it to the 0 (OFF) position.
3. Turn the ON/OFF knob on the gas valve clockwise to the OFF position.
4. The appliance is now completely shut down and can be cleaned if desired.

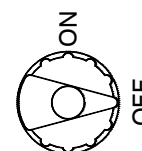

3. PREVENTATIVE MAINTENANCE

3.1. DAILY PREVENTATIVE MAINTENANCE

Performing the preventative maintenance steps below on a daily basis will keep your equipment safe and at peak performance. During the cooking process, starch build up will form on the temperature probes, tank and heating element. It may be necessary to clean these components more than once a day.

WARNING
The power supply must be disconnected before cleaning and servicing this appliance!

3.1.1. APPLIANCE INSPECTION

- ✓ Check that the high temperature limit, and temperature probe are in the correct position and secured in place.
- ✓ Check that wires and cords are not frayed or loose in and out of the cabinet.
- ✓ Check around the appliance for loose parts or accessories that need to be secured or other foreign items (ex: Aerosol cans) that should be removed from the area.
- ✓ Check for water leaks around the drain lines and water supply in and out of the cabinet and around the appliance.

WARNING
Wear protective gloves and clothing when cleaning and draining the appliance and when disposing of water. The water is extremely hot and can cause severe injuries.

3.1.2. CLEANING THE COOK TANK

1. Turn the appliance off.

<p>WARNING Read the operation section of this manual prior to filling or operating the appliance.</p>	<p>WARNING DO NOT leave the appliance unattended during cleaning.</p>
--	--

2. Scrub the tank, basket hanger, baskets, and temperature probe using a Scotchbrite™ or other abrasive pad with a commercial type cleaner specifically designed for cleaning and sanitizing food contact surfaces. Follow the directions and familiarize yourself with the safe use of this cleaner prior to using it to clean the appliance. Care must be taken to remove all the foreign material on the tank and on components in the tank.
3. When cleaning is complete, rinse the inside of the tank and its components thoroughly with cool water. Continue to rinse at least twice or until the cleaner has been completely and thoroughly rinsed from the tank.

3.1.3. CLEANING THE CABINET

1. The inside of the cabinet should be cleaned with a clean dry cloth removing oil, dust, dirt and cooking debris on all accessible surfaces and components.
2. The outside of the cabinet should be cleaned with a wetted cloth and mild detergent to remove oil, dust, dirt and debris. Be careful not to introduce the detergent into the tank and food zone regions of the appliance.

3.2. MONTHLY PREVENTATIVE MAINTENANCE

Water can leave mineral deposits inside the tank. Performing the monthly preventative maintenance steps below will keep your equipment safe and at peak performance. It may be necessary to clean these components more than once a month.

3.2.1. DELIMING

1. Read the “operation” section of this manual prior to filling or operating the appliance.
2. Following the manufacturer’s deliming instructions, remove deposits from the tank’s interior.
3. When cleaning is complete, rinse the inside of the tank and its components thoroughly with cool water. Continue to rinse at least twice or until the cleaner has been completely and thoroughly rinsed from the tank.
4. Using a clean dry cloth, wipe out all of the water.

3.3. ANNUAL/PERIODIC PREVENTATIVE MAINTENANCE AND INSPECTION

This section should ONLY be performed by a qualified service technician as part of a regular kitchen maintenance program. This inspection should take place a minimum of once a year by an Authorized Service Technician recommended by Pitco. It may be necessary perform this inspection more than once a year.

3.3.1. TEMPERATURE PROBE & HIGH LIMIT PROBE

- ✓ Verify probes are in good working condition. Check for damage and that the fasteners are tightly secured to the tank.
- ✓ Verify compression fittings are leak free.
- ✓ Check wiring for loose electrical connections.

WARNING
The power supply must be disconnected before cleaning and servicing this appliance!

3.3.2. CONTROLLER

Perform the following inspection if the appliance is equipped with a temperature controller.

- ✓ Verify that the controller is in good mechanical condition. Check all lights, displays and switches to assure that they are working properly. Examine overlay for damage that could allow moisture to enter.
- ✓ Check for loose electrical connections.
- ✓ Verify simmer temperature. Check temperature 1” above controller probe, if necessary check probe resistance.
- ✓ Check drain valve interlock (if provided) to ensure that the appliance stops heating when the drain valve is open.

3.3.3. CONTROL BOX & ELECTRICAL COMPONENTS

- ✓ Verify that all components (transformer, terminal block, relays, drain switches, etc...) are in good condition. Verify that wires are tight and in good condition.
- ✓ Verify enclosures are free of leaks. Check for water stains and wet surfaces.
- ✓ Verify that the covers and panels are in tact and provide a safe condition. Check for loose parts.
- ✓ Verify power cord is in good condition. Check for frayed or exposed wires. Verify that the insulation is in good condition and the attachment to the appliance is tight.

3.3.4. TANK

- ✓ Verify that the tank is in good condition. Check for scale build up and inspect for signs of corrosion. Verify that tank is leak free. Check drain overflow (if equipped) for scale build up and debris blockage.

3.3.5. DRAIN SYSTEM

- ✓ Verify that drain valve is in good condition. Check for leaks in the seal area and fitting region.
- ✓ Verify that drain lines are leak free, kink free and in good condition. Check for scale build up and debris blockage. Verify that the clamps and connections are securely tightened.

3.3.6. GAS COMBUSTION SYSTEM

- ✓ Check for gas leaks.
- ✓ Check and clean vent tube on gas valve pressure regulator.
- ✓ Check burners, clean debris and grease from pilot and pilot orifice tips.
- ✓ Check and adjust burner manifold gas pressure to nameplate reading.
- ✓ Check incoming gas pressure when all gas appliances are on.

- ✓ Check ignition system and adjust pilot flame as required.
 - Check flame sensor reading.
 - Matchless Ignition: Check gap spacing and clean igniter.
- ✓ Recheck for gas leaks after inspection.

3.4. VENTILATION HOOD

Proper ventilation hood operation is very important for the correct operation of this appliance and the safety of personnel. The ventilation hood should be inspected at the time of installation of this appliance to insure that it will operate properly in conjunction with the appliance. A regular schedule of examination, in accordance with ANSI/NFPA 96 latest edition and/or local codes must be followed.

4. TROUBLESHOOTING

4.1. POWER FAILURE

If electric power is removed for any reason, the appliance will shut down. Wait five minutes after the power is restored before attempting to restart the appliance. This will allow time for any gas that may have accumulated in the burner or tubes to dissipate. To restart the appliance, follow the appliance start up procedure in section 2.2.

CAUTION
DO NOT attempt to operate this appliance during a power outage.

4.2. HIGH TEMPERATURE LIMIT

This appliance is equipped with a high temperature limit switch. The high temperature limit switch will stop the appliance from functioning if the internal cook tank reaches an unsafe temperature. In the event that the high temperature limit has tripped, Please refer to the following procedure to reset the switch.

1. Turn the appliance off.
2. Allow the appliance ample time to cool to room temperature.
3. Add water to the cook tank as needed.
4. Press the high temperature reset button if equipped.
5. The high limit switch is now reset and the appliance is ready for start up.

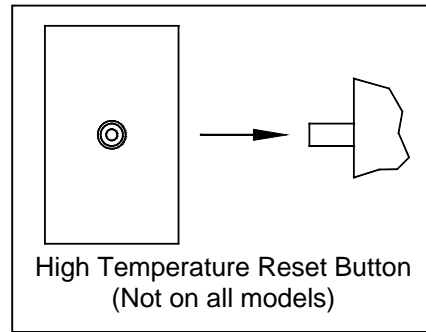

WARNING
DO NOT add water to the tank until it has been given ample time to cool down. Failure to do so may result in damage to the appliance and/or injury to the operator.

4.3. DRAIN VALVE INTERLOCK

If your appliance is equipped with a drain valve interlock circuit, the appliance will stop heating if the tank drain valve is opened. In some cases the appliance will turn off. Refer to the following procedure to resume operation after the drain valve interlock is tripped.

1. Turn the appliance OFF (if not already OFF).
2. Close the tank drain valve and fill the tank with water.
3. Turn the appliance ON.

4.4. TROUBLESHOOTING CHART

Problem	Probable Causes	Corrective Actions
Controller does not activate.	No power to appliance.	Check main building power supply.
	Circuit Breaker tripped.	Reset circuit breaker.
	I/O Switch in 0 position.	Flip I/O switch to I position and turn on controller.
	Controller not turned on.	Turn on controller.
	Power Cord loose or not connected.	Connect power cord.
Autofill does not add water.	Water not turned on.	Turn on water.
	Lower water level sensor is wet.	Dry off sensor.
Autofill does not shut off when full.	Dirty upper water level sensor.	Clean upper water level sensor.
	Insufficient mineral content in water.	Add 1/8 cup baking soda to cook tank.
Controller displays that it is heating but water will not heat.	Autofill system has cutoff heat.	Allow Autofill system to fill tank and restore heat.
	High temperature limit has tripped	Allow appliance to cool and reset High temperature limit.

4.5. CONTROLLER WARNING DISPLAYS

If your appliance is equipped with a temperature controller it may display the following warnings on its display.

Display	Problem	Action
	Water temperature is low.	Wait for appliance to heat up.
	Incorrect probe reading.	Contact Authorized Service Company.
	Water level is low.	Turn off appliance. Allow ample time for appliance to cool before filling with water and turning on.
	Incorrect probe reading.	Contact Authorized Service Company.
	Drain valve is open while controller is on.	Turn off appliance. Close drain valve before turning appliance back on.



In the event of problems with or questions about your order, please contact the Pitco Frialator factory at:
(603) 225-6684 World Wide
Website Address: www.pitco.com

In the event of problems with or questions about your equipment, please contact the Pitco Frialator Authorized Service and Parts representative (ASAP) covering your area, or contact Pitco at the numbers listed to the left.

MAILING ADDRESS – P.O. BOX 501, CONCORD, NH 03302-0501
SHIPPING ADDRESS – 10 FERRY ST., CONCORD, NH 03301