



Anets Inc.

Mailing Address: P.O. Box 501, Concord, NH 03302-0501 USA Telephone: 603-225-6684

Shipping Address: 10 Ferry Street, Concord, NH 03301 USA

www.anets.com



ANETS

FRYER

Model

SLG40

**Installation,
User Operation,
&
Maintenance
Manual**

SLG40 shown on standard 6" legs



DANGER

Improper installation, adjustment, alteration, service, or maintenance can cause property damage, injury or death. Read the installation, operating and maintenance instructions thoroughly before installing or servicing this equipment.



FOR YOUR SAFETY

DO NOT store or use gasoline or other flammable vapors or liquids in the vicinity of this or any other appliance.



WARNING

After installation of this equipment, immediately contact your local gas supplier to obtain information about what action to take whenever any person smells gas. *Post this information in a prominent location.*

Keep this Manual in a Convenient Location for Reference



*The Anets SilverLine
Quality Equipment For The Restaurant, Supermarket, and Bakery Industries*



⚠ DANGER

Read these specifications, Code Requirements, Installation Requirements, Installation Instructions, and Operating Instructions very carefully. Failure to follow the Instructions could cause the fryer to malfunction. A fryer malfunction can result in property damage, serious bodily injury, or death.

CONTENTS

Shipping Container Inspection 3

Fryer Gas Supply Specifications 3

Fryer Electrical Specifications 3

Figure 1 - Fryer Wiring Diagram 3

Code Requirements 4

Figure 2 - Fryer Site Installation Requirements 4

Installation Requirements 5

 Fryer Restraining Device Installation Instructions 5

 Leg Installation Instructions 6

Figure 3 - Leg Installation 6

 Leg Leveling Instructions 6

 Caster Installation Instructions 6

Figure 4 - Caster Installation 6

 Caster Leveling Instructions 6

Gas Connection Instructions 7

Fryer Operation Recommendations 7

Fryer Operating Instructions 8

 Fryer Preparation For Use 8

Figure 5 - Draining The Kettle 8

 Lighting Procedure 9

Figure 6 - Gas Safety Valve & Control Knob Positions 9

 Shutdown Procedure 9

 Daily Cleaning Procedure 10

 Monthly Maintenance Instructions 10

Fryer Troubleshooting Guide 11-14

Fryer Warranty 15

SHIPPING CONTAINER INSPECTION

1. Carefully examine the shipping carton for external damage. When damage is noted, notify the delivery carrier immediately. **Save all packing materials for damage claim examination.**
2. If no external damage is noted, remove the shipping carton from the fryer and examine the fryer carefully for damage. Place the fryer in a safe location, if damage is noted, so that the freight damage claims adjuster can examine the fryer.
3. Save the shipping container for use during leg/ caster installation. Refer to the Installation Instructions for that procedure.

Standard Accessories furnished in the shipping carton for this fryer include:

- 2 Fryer Baskets 1 Screen
- 4 Adjustable Legs
- 1 Drain Valve Extension
- 1 Basket Hanger 1 Flue Deflector

Optional Accessories available for this fryer include:

- Single or Triple Fryer Baskets
- 1 Set (4) of Casters

FRYER GAS SUPPLY SPECIFICATIONS

Please make sure that your desired fryer location has gas supply factors that are suitable for this product:

INPUT REQUIRED: 90,000 BTU/Hr *	Natural Gas	Propane
MANIFOLD PRESSURE	3½" W.C. **	10" W.C.
SUPPLY PRESSURE ***	6" W.C., minimum	11" W.C., minimum

* - Rating is based on sea level operation. Reduce rating 4% for each 1000 feet *above* sea level.

** - "W.C. = Inches, Water Column.

*** - Measure Supply Pressure when all other gas-powered equipment is operating.

Gas Supply Inlet Pipe must be ½" standard gas line. The gas supply inlet line should be as straight as possible (fewest bends or elbows) to obtain the highest available gas pressure at the fryer. Locate this inlet line horizontally at the center of the desired fryer location, approximately 8¼" above the floor.

NOTE: Using a flexible inlet line permits variation in the gas supply line location, both horizontally and vertically.

Anets fryers are only for use with the type of gas specified on the spec plate. If a fryer requires modification to use a gas other than that which is identified on the fryer spec plate, contact your Anets representative or call 1-603-225-6684.

FRYER ELECTRICAL SPECIFICATIONS

The ANETS Fryer Model SLG40 requires no external electric power source.

Figure 1 is the wiring diagram of an *ANETS* SLG40 Fryer.

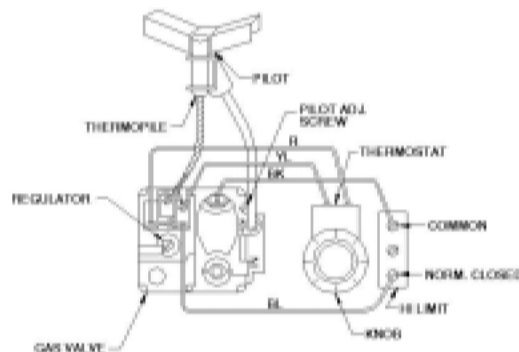

Figure 1. Fryer Model SLG40 Wiring Diagram³

CODE REQUIREMENTS

IMPORTANT: Read the Code Requirements and ALL installation instructions carefully, before starting the installation. Contact the factory (1-603-225-6684) if any problems or questions arise.

The fryer installation must conform with local codes, or in the absence of local codes, with the National Fuel Gas Code, ANSI Z223.1 (latest edition); the Natural Gas Installation Code, CAN/CGA-B149.1 (latest edition); or the Propane Gas Installation Code, CAN/CGA-B149.2 (latest edition), as applicable, including:

- a. Disconnect the fryer and its individual shutoff valve from the gas supply piping system during any pressure testing of the gas supply system at test pressures in excess of ½ psig (3.45 kPa).
- b. Isolate the fryer from the gas supply piping system during any pressure testing of the gas supply system at test pressures equal to or less than ½ psig (3.45 kPa).
- c. For fryers utilizing floor casters, the fryer installation shall be made with a connector that complies with the Standard for Connectors for Movable Gas Appliances, ANSI Z21.69 (latest edition) or CAN/CGA 6.16 (latest edition), and a quick-disconnect device that complies with the Standard for Quick-Disconnect Devices for Use with Gas Fuel, ANSI Z21.41 or CAN/CGA 1-6.9 (latest edition).

d. Restrict the movement of a caster-equipped fryer by using a limiting device (for example, a cable attached both to the fryer **and** to a fixture attached to the site structure) to avoid depending on the connector and the quick-disconnect device or its associated piping to limit fryer movement.

e. Install this fryer on a non-combustible floor with its back and sides *at least* 6" away from any combustible wall, as shown in Figure 2.

WARNING

Install this fryer under a ventilation hood that conducts combustion products outside the building. Venting must comply with ANSI/NFPA 96 (latest edition).

f. Install this fryer in a location where adequate combustion and ventilation air is available. Keep the area directly in front of the fryer open for adequate air flow to the burners. **DO NOT** obstruct the flow of combustion and ventilation air.

g. Keep the fryer area free and clear from combustibles and debris.

h. Attach a restraining device to each fryer, to prevent the unit from tipping, which could cause splashing of hot liquid .

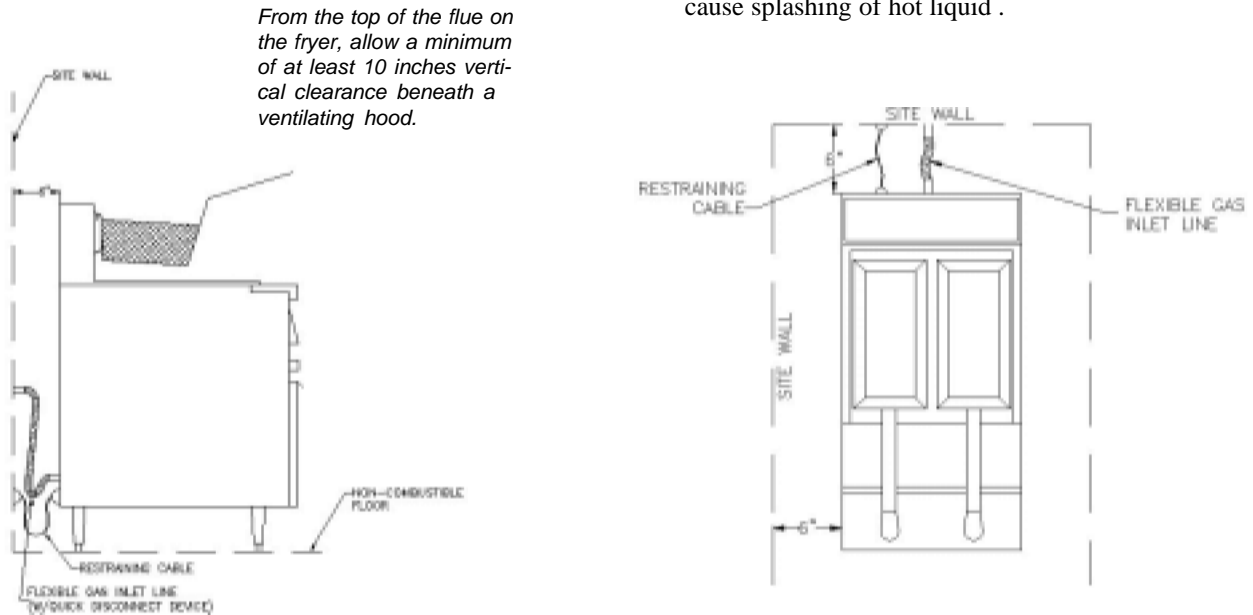

Figure 2. Fryer Model SLG40 Site Installation Requirements

INSTALLATION REQUIREMENTS

Install the fryer in accordance with the preceding Code Requirements, as well as the following Installation Requirements.

1. DO NOT install this fryer in a mobile home, trailer, or recreational vehicle.
2. Install this fryer in a location that allows it to be moved away from other adjacent appliances for cleaning and maintenance.

NOTE: If the fryer is installed among a row of appliances (“banked”), with its only convenient movement forward, sufficient room must be available in front of the fryer to permit its separation from adjacent appliances for cleaning and maintenance.

3. Tightly fasten the legs (or casters) to the bottom of the fryer using the supplied hardware, to prevent the fryer from tipping, wobbling or rocking when it is in its

desired location. Refer to the following **Leg Installation Instructions** or **Caster Installation Instructions** for leg or caster attachment and leveling information.

4. Confirm that the air from the ventilation hood flowing near the fryer after installation is **NOT** blowing on the rear of the unit, to prevent affecting the burner flames and possibly causing control damage.



CAUTION: Hood make-up air **MUST NOT** flow in a manner that restricts or impedes the natural flow of combustion or ventilation air.

FRYER RESTRAINING DEVICE INSTALLATION INSTRUCTIONS



WARNING

Fryers **MUST** have a movement-limiting (restraining cable) device installed to prevent tipping that causes splashing or spilling its **HOT** contents.

NOTE: This movement-limiting device is to be **furnished and installed** by the fryer’s installing contractor **before** the fryer is connected to the gas line at its desired location.

1. Install one restraining device connector securely into the structure wall directly behind the fryer’s desired location (Figure 2).
2. Install one restraining device connector on the rear panel of the fryer very close to the quick-disconnect device on the end of the fryer’s gas line.
3. Attach one end of the restraining cable to the wall connector. Attach the other end to the fryer connector.
4. Confirm that the fryer cannot move far enough away from the wall to cause excessive movement of the flexible gas line or its associated connectors.

LEG INSTALLATION INSTRUCTIONS

1. Position the fryer on its side on a clean surface.
2. Attach each leg with four bolts, washers and nuts (provided).
3. Tighten securely

LEG LEVELING INSTRUCTIONS

1. Move the fryer to its desired location.
2. Turn the screw-type leg adjustment ends as necessary to level the fryer, until NO tipping, rocking, or wobbling is evident.
3. Perform the “**Fryer Restraining Device Installation Instructions.**”

 **WARNING**
The fryer **MUST NOT** tip, rock or wobble, to avoid splashing or spilling its **HOT** shortening contents during operation.

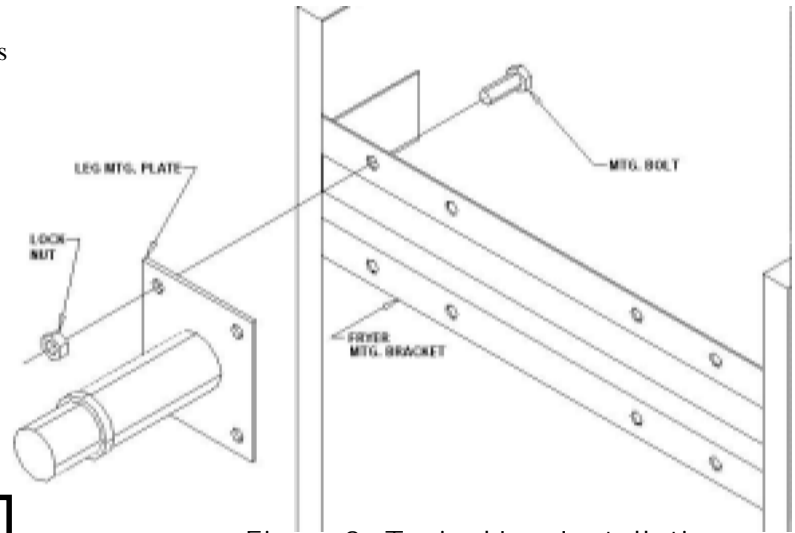

Figure 3. Typical Leg Installation

CASTER INSTALLATION INSTRUCTIONS

1. Position the fryer on its side on a clean surface.
2. Attach each caster with four bolts, washers, and nuts (provided).
3. Mount locking casters on the front of the fryer and fixed casters on the rear.
4. Tighten securely.

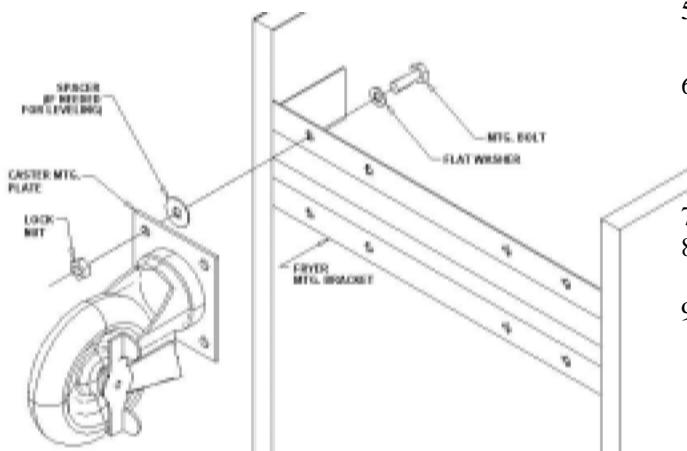

Figure 4. Typical Caster Installation

CASTER LEVELING INSTRUCTIONS

1. Move the fryer to its desired location.
2. Determine whether the fryer tends to wobble or rock when in its desired location. If it *does*, perform steps 3 through 9. If it does not, skip to step 10, then proceed to the **Installation Instructions.**
3. Determine which caster requires adjustment and the approximate amount of change required to level the fryer.
4. Position the fryer on its side, exposing the bottom of the fryer (Figure 5).
5. Completely remove the bolts. Retain the bolts for later reassembly.
6. Reinsert each mounting bolt through the caster mounting plate; next, place a spacer of the required size on the bolt before inserting the bolt into the bottom of the fryer.
7. Repeat step 6 for all remaining bolts.
8. Tighten all four bolts with locking nuts evenly and securely against the bottom of the fryer. Return the fryer to its desired location. Lock the front casters to prevent fryer movement and check again for wobbling or rocking.
9. Repeat steps 4 through 8 until no wobbling or rocking occurs. When the fryer no longer wobbles or rocks, perform step 10.
10. Next, perform the “**Fryer Restraining Device Installation Instructions.**”

GAS CONNECTION INSTRUCTIONS

Installing your *ANETS* Fryer requires the following procedure, after its legs or casters are properly attached and it is in its desired location.

1. Ensure that the gas safety valve control knob in the fryer has its OFF position next to the valvemark.
2. Ensure that the gas supply inlet line valve is closed (crosswise to the line direction).
3. Ensure that the fryer's thermostat is set to OFF.
4. Connect the ½" gas supply line to the gas line adapter on the lower rear of the fryer.

5. Turn the gas supply line valve ON; then, check all gas supply line joints and couplings for leaks using soap suds or a leak-check solution, after the fryer is in its desired location.
6. Refer to **Fryer Operation Recommendations** and **Fryer Operating Instructions** to begin using your *ANETS* Fryer.

 **WARNING**
DO NOT use a flame to check for leaks.

FRYER OPERATION RECOMMENDATIONS

 **CAUTION**
DO NOT attempt to operate this fryer during an interruption of gas service. Turn all fryer controls to OFF, including the gas control valve knob, then close the gas supply line valve. When notified that the interruption of gas service has ended, perform the Lighting Procedure (later in this manual).

 **DANGER**
NEVER operate this fryer when its flue is blocked because the combustion products can cause injury to personnel.

Please observe the following recommendations to obtain the optimum results from your *ANETS* Fryer.

 **DANGER**
Avoid moving the fryer while it contains HOT shortening. Drain the shortening from the fryer before moving it for service, cleaning or maintenance to avoid spilling or splashing. Burns from hot shortening can cause serious injury or death.

- A. An *ANETS* Model SLG40 Fryer is designed for operation with a kettle filled with approximately 35 to 40 pounds of liquid shortening. (This is approximately 3½ to 5 gallons.)

CAUTION: DO NOT melt solid shortening in this fryer because the melting can damage the kettle, which will void the fryer warranty.

Shortening must be melted into the liquid state **before** it can be used in an *ANETS* Fryer.

- B. Schedule regular cleaning of the fryer to ensure long-term satisfactory operation. Refer to the **Daily Cleaning Procedure**, later in this manual.
- C. Before servicing and maintenance, allow the fryer to cool. **ALWAYS** shut off gas to the fryer while working on it, to prevent burns.
- D. Contact the factory (1-603-225-6684) for warranty service authorization. [**Always notify the factory the next business day about 'after-hours' warranty service.**] Contact your local restaurant equipment service agency for other service, repairs, or maintenance activities, as necessary.

FRYER OPERATING INSTRUCTIONS

Normal operation of an *ANETS* Fryer requires that the kettle is filled with liquid shortening to above the lower indent level marked on the rear of the kettle, before lighting the fryer's main burners.



CAUTION: Shortening **MUST** be in liquid form to avoid scorching or discoloration and possible damage to the kettle. Damage caused by melting solid shortening will **NOT** be covered by the warranty.

FRYER PREPARATION FOR USE

“BOIL OUT” INSTRUCTIONS

Before using the newly installed fryer for food preparation, clean the rust preventive material from the kettle:

1. Thoroughly wipe the interior of the kettle with clean cloths. Open the front door on the lower portion of the fryer to access the drain ball valve. Open the drain ball valve (by aligning the valve handle with the drain ball valve) and wipe the entire drain line clean of rust preventive material.

2. Close the drain ball valve (turn the valve handle cross-wise to the drain ball valve). Fill the kettle with water to about 3" from the top. Add 1 to 2 cups of low sudsing soap powder, washing soda (trisodium phosphate), or deep fat fryer kettle cleaner.

3. Perform the **Lighting Procedure** for the fryer. (Refer to the **Lighting Procedure** later in this manual.)

4. Set the thermostat to 190°F. Heat, but **DO NOT** boil the water. Stir the water to dissolve the cleaning material.

5. Clean the fryer kettle for at least 20 minutes. Use a small hand mop (an optional brush can be ordered for this purpose) to clean the upper portion of the kettle (above the 3" waterline) and the top rim of the kettle.

6. Shut down the fryer using the **Shutdown Procedure** for the fryer. Refer to the **Shutdown Procedure** later in this manual. Allow the water to cool slightly.

7. Open the front door and mount the drain extension to the drain ball valve. Position a container (bucket) capable of holding **VERY HOT** cleaning solution beneath the end of the drain extension to hold the cleaning solution being drained, as shown in Figure 5.

8. Open the drain ball valve **SLOWLY**, to avoid splashes while draining the cleaning solution from the kettle.

9. Close the drain ball valve (valve handle *cross-wise*) and remove the drain extension. Close the front door.

10. Safely dispose of the cleaning solution.

11. Fill the kettle with water to about 3" from the top. Add 2 cups of vinegar to neutralize the cleaning solution.

12. Repeat steps 3 through 10 of this procedure.

13. Thoroughly wipe the interior of the kettle and the drain ball valve with clean, dry, wiping cloths to remove **ALL** water.

14. Dry the kettle thoroughly because any remaining water can cause spattering of hot shortening when the kettle is later filled and heated.

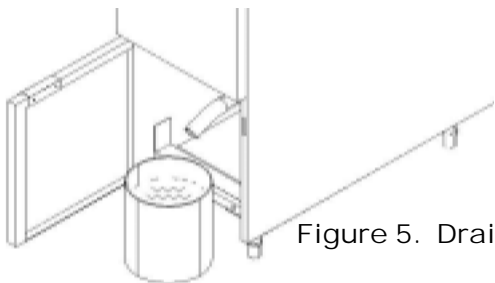

Figure 5. Draining The Kettle

FRYER OPERATING INSTRUCTIONS (Continued)

LIGHTING PROCEDURE

NOTE: The gas line of a new fryer installation may contain a considerable amount of air which will hinder immediate lighting. You may have to press in the control knob as long as several minutes before the pilot flame burns steadily.

1. Open the front door and ensure that the fryer's thermostat knob is set to OFF.
2. Open the gas supply line inlet valve to the fryer by aligning the gas valve handle with the gas line piping.
3. Turn the gas control valve knob to align the PILOT setting with the valve mark. Figure 6 shows the possible control knob positions.
4. Press, and *hold down*, the valve control knob to allow pilot gas to flow. Apply a lighted match to the end of the pilot burner, until the pilot flame lights.

NOTE: A butane lighter may also be used to light the pilot flame.

Continue holding down the control knob for *at least* 30 seconds until the pilot flame burns steadily, without going out.

5. Release the control knob and observe that the pilot flame remains lighted.
6. Turn the gas control valve knob to align the ON setting with the valve mark.
7. Turn the thermostat knob to the desired temperature. Observe that the fryer's main burners light to heat the kettle.

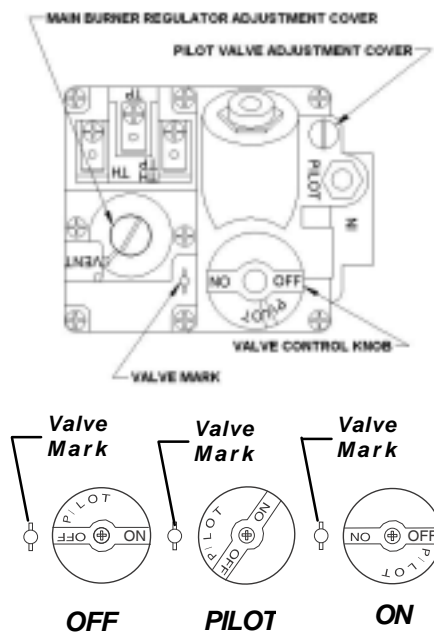

Figure 6. Gas Control Valve & Knob Positions

SHUTDOWN PROCEDURE

NOTE: Shutdown is *recommended* at the end of a workday or whenever no frying is scheduled for a period of several hours. To prevent damage, the fryer **MUST** also be shutdown whenever there is no shortening in the kettle.

1. Turn the thermostat knob to OFF.
2. Turn the gas control valve knob to align the PILOT setting with the valve mark. Observe that the main burners' flames go out.
3. Press *down* and turn the gas control valve knob to align the OFF setting with the valve mark. Observe that the pilot flame goes out.

NOTE: For extended periods of non-use *or* when servicing the fryer, close the gas supply line inlet valve to the fryer by turning the gas valve handle cross-wise with the gas line piping.

FRYER OPERATING INSTRUCTIONS *(Continued)*

DAILY CLEANING PROCEDURE

NOTE: Cleaning is *recommended* at the end of a workday to prepare the fryer for proper operation the next time it is to be used.

DANGER

Avoid moving the fryer while it contains HOT shortening. Drain the shortening from the fryer before moving it for service, cleaning or maintenance to avoid spilling or splashing. [Refer to steps 1 through 7.] Burns from HOT shortening can cause serious injury or death.

1. Open the front door of the fryer. Attach the drain extension to the drain ball valve.
2. Perform the **Shutdown Procedure**. Ensure that the gas supply line inlet valve is closed (handle cross-wise to pipe line) and the pilot flame is extinguished.
3. Position a steel drum [NEVER use plastic!] with a filter cone directly beneath the drain extension end.
4. Slowly open the drain ball valve to drain the HOT shortening.
5. Remove the fryer baskets and screen from the kettle. Remove the basket hanger from the flue. Clean, and rinse, these items in the sink. MAKE SURE that these items are completely dry before their next use.
6. Clear any sediment blocking the kettle drain. Flush out all sediment in the bottom of the kettle by pouring filtered liquid shortening into the kettle until the shortening being drained runs clear.
7. Close the drain ball valve, after the kettle is completely empty of shortening and sediment. Detach the drain extension. Clean, rinse, and dry it before storing.



WARNING
Wait until the kettle has cooled before performing step 8, to avoid injury from burns.

8. Thoroughly wipe the kettle interior using clean cloths.
9. Periodically perform the **“BOIL OUT” Instructions** to ensure thorough cleaning of the kettle. (Refer to the earlier FRYER PREPARATION FOR USE section.)
10. Return the fryer to its normal operating location, if it was moved for cleaning, and reconnect both the gas supply line and the movement-limiting cable. (For caster-

equipped fryers, lock the locking casters to prevent movement.)

11. Refill the kettle with filtered (or fresh) liquid shortening to the desired indent mark on the rear wall of the kettle, *only* if fryer operation is to continue during a subsequent shift. Otherwise, melt shortening into its liquid state and refill the kettle before fryer operation is scheduled during the next normal working shift.
12. Attach the basket hanger to the top of the backsplash panel. Return the screen and fryer baskets to their proper positions on the basket hanger.
13. Perform the **Lighting Procedure** to return the fryer to operation, when desired.

MONTHLY MAINTENANCE INSTRUCTIONS

NOTE: Regular maintenance is *recommended* to keep the fryer operating properly.

Once each month, before beginning fryer operation, check the flue (behind the backsplash panel) to ensure that it is clear and free of obstructions, enabling exhaust combustion gases to flow freely toward the ventilation hood area. DO NOT allow the flue to become excessively dirty.

Monthly, observe the condition of the ventilation hood. If it shows evidence of a great deal of greasy residue, remove (clean) the residue to allow free flow of ventilation air.

FRYER TROUBLESHOOTING GUIDE

All service (repairs or part replacement) must be performed by a qualified Service Agency.

<i>PROBLEM</i>	<i>CAUSE</i>	<i>REMEDY</i>
<p>Pilot flame does not stay lighted.</p>	<ol style="list-style-type: none"> 1. Dirty/sooty pilot burner. 2. Low gas supply pressure [less than 6" W.C. for natural gas (11" W.C. for propane) when all other gas-powered equipment is operating.]. 3. Pilot flame too small to heat thermo pile. 4. Pilot flame 'wavering' (being blown about by a draft). 5. Improper thermopile output voltage (must be at least 180 millivolts, measured at the thermocouple junction block). 6. High-limit thermostat problem has shut off the gas. 	<ol style="list-style-type: none"> 1. Clean the pilot burner. Perform the Lighting Procedure. 2. Measure the gas supply pressure. Contact your local gas supplier to obtain adequate gas supply volume and pressure. 3. Adjust the pilot valve (part of the gas safety valve) to increase the flame size: Unscrew and retain the large threaded cover; turn the pilot valve adjustment screw <i>two turns</i> counterclockwise; reinstall the threaded cover. 4. Block or redirect the draft, to keep the flame burning steadily. 5. Replace the thermopile. 6. Check for, and repair, any damaged high-limit thermostat wiring. Otherwise, test the high-limit thermostat by bypassing the high-limit thermostat (black and blue wires) at the gas control valve with a jumper wire. Next, perform the Lighting Procedure, to check whether the pilot flame lights. If the pilot flame lights and stays lit, the high-limit thermostat has failed and must be replaced.
	<ol style="list-style-type: none"> 7. Gas control valve has failed. 	<div style="border: 1px solid black; padding: 5px; margin-bottom: 5px;"> <p> CAUTION: DO NOT return the fryer to normal operation with its high-limit thermostat bypassed.</p> </div> <ol style="list-style-type: none"> 7. Replace the gas control valve.

FRYER TROUBLESHOOTING GUIDE (Continued)

<i>PROBLEM</i>	<i>CAUSE</i>	<i>REMEDY</i>
<p>Pilot flame goes out repeatedly.</p>	<ol style="list-style-type: none"> 1. Low gas supply pressure [less than 6" W.C. for natural gas (11" W.C. for propane) when all other gas-powered equipment is operating.]. 2. Loose thermocouple or high-limit thermostat connection(s) on gas control valve. 3. Pilot flame does not continuously touch the thermocouple because of excessive air flow around the pilot burner assembly. 4. High-limit thermostat problem has shut off the gas. <div style="border: 1px solid black; padding: 5px; margin-top: 10px; text-align: center;">  <p>CAUTION: DO NOT return the fryer to normal operation with its high-limit thermostat bypassed.</p> </div>	<ol style="list-style-type: none"> 1. Measure the gas supply pressure. Contact your local gas supplier to obtain adequate gas supply volume and pressure. 2. Check and tighten the connections. 3. Block the excessive air flow to make the pilot flame contact the thermocouple. 4. Check for, and repair, any damaged high-limit thermostat wiring. Otherwise, test the high-limit thermostat by bypassing the high-limit thermostat (black and blue wires) at the gas control valve with a jumper wire. Next, perform the Lighting Procedure, to check whether the pilot flame lights. If the pilot flame lights and stays lit, the high-limit thermostat has failed and must be replaced.
<p>Main burners do not ignite.</p>	<ol style="list-style-type: none"> 1. Gas control valve knob set to OFF or PILOT. 2. Low gas supply pressure [less than 6" W.C. for natural gas (11" W.C. for propane) when all other gas-powered equipment is operating.]. 3. Pilot burner problem. 4. Thermostat control set below the temperature of the liquid shortening in the kettle. 	<ol style="list-style-type: none"> 1. Perform the normal Lighting Procedure. Turn the gas control valve knob to ON to light the main burners. If the burners do not light, the gas safety valve has failed and must be replaced. 2. Measure the gas supply pressure. Contact your local gas supplier to obtain adequate gas supply volume and pressure. 3. Refer to the preceding Pilot Burner problems and use the correct remedy. 4. Increase the thermostat setting until the burners light. If this setting is greater than the desired temperature, reset the thermostat.

FRYER TROUBLESHOOTING GUIDE (Continued)

<i>PROBLEM</i>	<i>CAUSE</i>	<i>REMEDY</i>
Main burners do not ignite. (Continued)	5. Gas control valve has failed.	5. Replace the gas control valve.
Main burners do not stop burning.	1. Thermostat has failed. 2. Gas control valve has failed.	1. Turn the thermostat control knob to OFF. If the burners do not quit burning, the thermostat has failed and must be replaced. 2. Turn the gas control valve knob to OFF. If the burners do not quit burning, the gas control valve has failed and must be replaced.
Liquid shortening does not reach the desired temperature for frying.	1. Low gas supply pressure [less than 6" W.C. for natural gas (11" W.C. for propane) when all other gas-powered equipment is operating], causing reduced heat from main burners. 2. Low gas manifold pressure [less than 3½" W.C. for natural gas (10" W.C. for propane). 3. Loose knob on thermostat; or thermostat requires calibration (temperature setting differs by about 10°F from the measured shortening temperature).	1. Measure the gas supply pressure. Contact your local gas supplier to obtain adequate gas supply volume and pressure. 2. Measure the gas pressure at the fryer's manifold pressure tap. Adjust the manifold pressure (see Figure 6), as necessary: [a] Unscrew (and retain) the threaded Main Burner Regulator Adjustment Cover. [b] Use a flat-blade screwdriver to turn the regulator adjustment screw (clockwise to increase; counterclockwise to decrease) to reset the pressure adjustment. [c] Reinstall, and tighten the Regulator Adjustment Cover, when finished. 3. Stir the shortening to mix the hot shortening with some from the lower 'cool zone' and allow it to sit for 5 minutes. Turn the thermostat knob until it 'clicks' <i>on</i> (causing the main burners to flame); note the setting where this occurs. Turn the thermostat knob until it 'clicks' <i>off</i> (causing the main burners to go out); note the setting where this occurs. Repeat this tempera-

FRYER TROUBLESHOOTING GUIDE (Continued)

<i>PROBLEM</i>	<i>CAUSE</i>	<i>REMEDY</i>
<p>Liquid shortening does not reach the desired temperature for frying. (Continued)</p>	<p>3. Loose knob on thermostat; or thermostat requires calibration (temperature setting differs by about 10°F from the measured shortening temperature). (Continued)</p>	<p>3. (Continued) ture ‘click points’ step at least three times to ensure that the shortening temperature has stabilized. Measure the temperature of the shortening by inserting an <i>accurate</i> thermometer about 4 inches into the shortening to measure its temperature. If the temperature difference between the measured temperature and the thermostat setting is more than 15°F the thermostat is failing and must be replaced.</p>

NOTE: A Parts List for each ANETS Fryer is among the items shipped with each fryer. If an additional copy of this list is needed, please contact the factory as directed on the back cover.



ORIGINAL EQUIPMENT LIMITED WARRANTY

General Warranty

Anets, Inc. warrants to the original user of its commercial cooking appliances and related equipment that said appliances and related equipment will be free from defects in material and workmanship under normal use for a period of one (1) year from the date of installation, with appropriate documentation, to a maximum of fifteen (15) months from the date of manufacture, subject to the following additions, exceptions, exclusions and limitations.

What is covered

This warranty is limited to the repair or replacement at the Company's option, without charge, of any part found to be defective within the warranty period and reasonable expenses incurred for freight and material for the installation of such part; in addition, the Company's obligation shall be limited to reimbursement for normal labor on such parts.

Anets, Inc. agrees to pay the Authorized Service and Parts Distributor, for any labor and material required to repair or replace, at the Company's option, any part which may fail due to defects in material or workmanship during the above general warranty period.

Silver Line Fryers

In addition to the above general warranty, for its economy fryers and cookers, the Company warrants to the original user any mild. Stainless steel fry tank or cooking vessel to be free from defects for a period of one (1) year, from the date of manufacture. Labor and freight shall be the responsibility of the end user.

Gold Line Fryers

In addition to the above general warranty, for its standard fryers and cookers, the Company warrants to the original user any stainless steel fry tank or cooking vessel to be free from defects for a period of (1) year parts and labor and 10 year Frypot or cooking vessel Part only from the date of manufacture. Labor and freight shall be the responsibility of the end user.

Pasta Cooker

In addition to the above general warranty, for its standard fryers and cookers, the Company warrants to the original user any stainless steel fry tank or cooking vessel to be free from defects for a period of one (1) year parts and labor and 5 years Frypot or cooking vessel part only after year one from the date of manufacture. Labor and freight shall be the responsibility of the end user.

Limitations to Fry Tank and Cooking Vessel Warranty

After the expiration of the general warranty period, any additional warranty on fry tanks or cooking vessels shall only obligate the Company to repair or replace, at its option, any fry tank or cooking vessel which it determines to be defective. Claims under this item shall be supported by a statement detailing the defect, and the Company may require the return of the fry tank or cooking vessel claimed to be defective. Labor and freight shall be the responsibility of the end user.

How to Keep Your Warranty in Force

- Make sure any shipping damages are reported immediately. Damages of this nature are the responsibility of the carrier and must be reported by the receiver.
- Install the unit properly. This is the responsibility of the installer and the procedures are outlined in the manual.
- Do not install it in a home or residence.
- Maintain it properly. This is the responsibility of the user of the appliance and the procedures are outlined in the manual.
- Adjustments, such as calibration, leveling, tightening of fasteners or plumbing or electrical connections normally associated with initial installation. These procedures are outlined in the manual and are NOT covered by warranty.
- If it is damaged due to flood, fire or other acts of God, this is not covered under this warranty.
- Use it for what it is intended. If it is used for a purpose other than for which it was intended or designed, resulting damages are not covered under the warranty.
- Make sure that it has the correct voltage, gas supply and/or good quality water. If a failure is due to poor water quality, harsh chemical action, erratic voltage or gas supplies, these damages are not covered under the warranty.
- Do not materially alter or modify from the condition in which it left the factory.
- Do not obliterate, remove or alter the serial number rating plate.
- Use only Genuine OEM parts from Anets, Inc. or its Authorized Parts and Service Distributors. Repairs are not covered by the warranty.
- If any other failure occurs which is not attributable to a defect in materials or workmanship, it is not covered.

This warranty specifically excludes parts which wear or would be replaced under normal usage, including, but not limited to, electric lamps, fuses, interior or exterior finishes, o-rings and gaskets.

Limits to the Warranty

Outside the United States of America and Canada, this warranty is limited to the replacement of parts and Anets, Inc. will not bear any other expense be it labor, mileage, freight or travel.

If any oral statements have been made regarding the appliance, these statements do not constitute warranties and are not part of the contract of sale. This limited warranty constitutes the complete, final and exclusive statement with regard to warranties.

THIS LIMITED WARRANTY IS EXCLUSIVE AND IS IN LIEU OF ALL OTHER WARRANTIES WHETHER WRITTEN, ORAL OR IMPLIED, INCLUDING, BUT NOT LIMITED TO ANY WARRANTY OF MERCHANTABILITY OR FITNESS FOR A PARTICULAR PURPOSE OR WARRANTY AGAINST LATENT DEFECTS.

Limitations of Liability

In the event of a warranty or other claim, the sole obligation of Anets, Inc. will be the repair or replacement, at the Company's option, of the appliance or the component part. This repair or replacement will be at the expense of Anets, Inc. except as limited by this warranty statement. Any repair or replacement under this warranty does not constitute an extension in time to the original warranty. Parts covered under this warranty will be repaired or replaced, at the Company's option, with new or functionally operative parts. The liability of Anets, Inc. on any claim of any kind, including claims based on warranty, express or implied contract, negligence, strict liability or any other legal theories will be exclusively the repair or replacement of the appliance. This liability will not include, and the purchaser specifically renounces any right to recover special, incidental, consequential or other damages of any kind, including, but not limited to, injuries to persons, damage to property, loss of profits or anticipated loss of the use of this appliance.

If any provision of this warranty is unenforceable under the law of any jurisdiction, that provision only will be inapplicable there, and the remainder of the warranty will remain unaffected. The maximum exclusion or limitation allowed by law will be substituted for the unenforceable provision.

How to Obtain Warranty Service

First direct your claim to the Anets, Inc. Authorized Service and Parts Distributor closest to you giving complete model, serial and code numbers, voltage, gas type, and description of the problem. Proof of the date of installation and/or the sales slip may also be required. If this procedure fails to be satisfactory, write the National Service Manager, Anets, Inc., P. O. Box 501, Concord, NH. 03302-0501. USA

This warranty gives you certain specific legal rights; you may have other rights which vary from state to state.

Anets, Inc., P.O. Box 501, Jct. I-89 & I-93 Concord, NH 03302-0501

509 Route 3A, Bow, NH 03304 USA

Tel: (603)225-6684 Fax: (603)228-5231 www.ANETS.com



In the event of problems with or questions about your order, please contact the Anets factory at:
(603)-225-6684 World Wide
Website Address: www.anets.com

In the event of problems with or questions about your equipment, please contact the Anets Authorized Service and Parts representative (ASAP) covering your area, or contact Anets at the number listed to the left.

MAILING ADDRESS – P.O. BOX 501, CONCORD, NH 03302-0501
SHIPPING ADDRESS – 10 FERRY STREET, CONCORD, NH 03301