

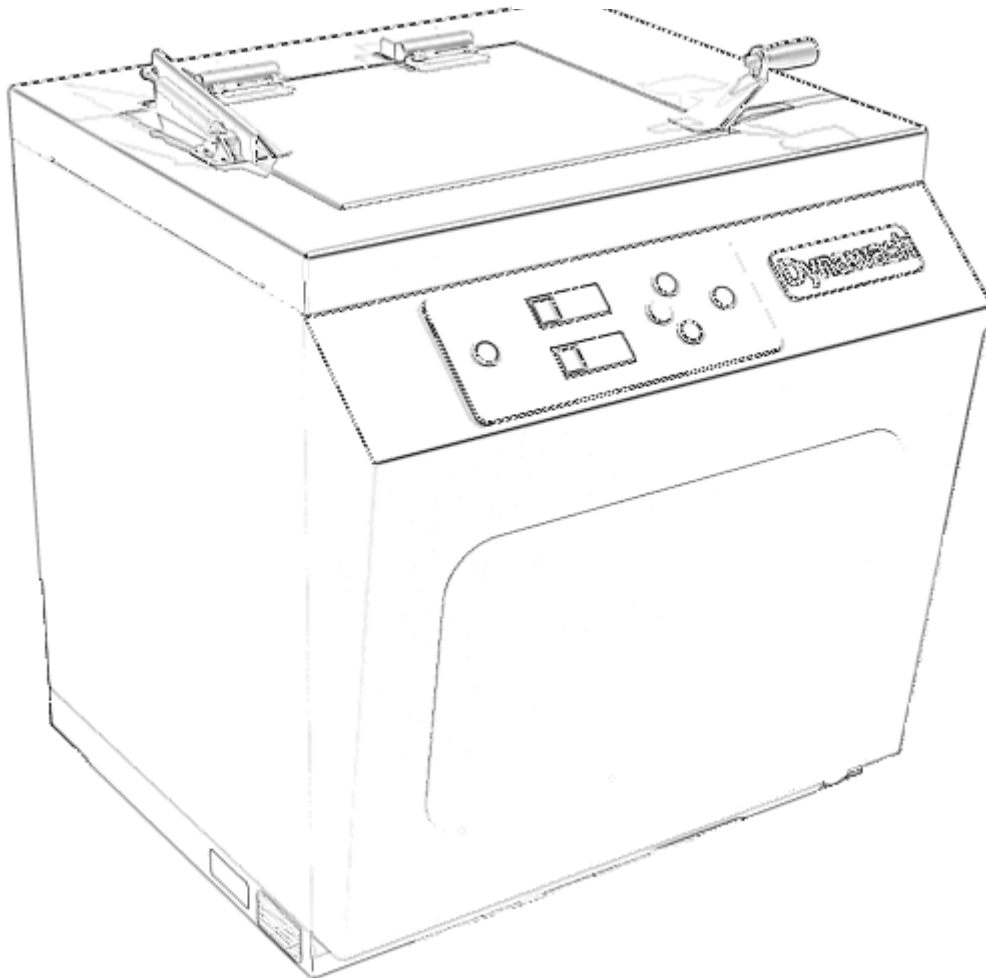

**JAMES H. HEAL**  
& CO. LTD. HALIFAX ENGLAND

# DYNAWASH

Durability Wash Tester  
Model 825



Covering Serial Nos. 825/08/1001 upwards

James H. Heal & Co. Ltd.  
Halifax, England

Publication 290-825\$A  
©James H Heal & Co Ltd. 2008



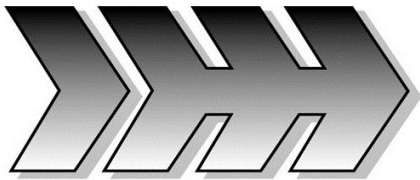

# 1. CONTENTS

---

## ***Table of contents***

1.	CONTENTS	2
	Table of contents	2
	List of tables	3
	Table of figures	3
2.	INTRODUCTION	4
	Key features and specification	4
	Retailer standards	5
	Consumables quick-selector	5
3.	SAFETY	6
	Correct use	6
	General safety considerations	6
4.	INSTALLATION	7
	Dynawash views and identification of key parts	7
	Installation safety	9
	Stainless steel surfaces	9
	Packaging	10
	Services required	10
	Electrical connection	11
	Water connection	12
	Drain connections	12
5.	OPERATION	13
6.	CLEANING	15
	General cleaning	15
7.	TROUBLE SHOOTING	16
	Electrical problems	16
	Mechanical problems	16
	Healink contacts	16
	How to order spare parts	17
	Spare parts list	17
8.	CONSUMABLES	18
9.	CE COMPLIANCE	19
	CE compliance statements	19

## ***List of tables***

Table 1: Consumables by Retailer Standard	5
---	---

## ***Table of figures***

Figure 1: Front view	7
Figure 2: Top view	7
Figure 3: Process bath	8
Figure 4: Sump	8
Figure 5: Dynawash control panel	8
Figure 6: UK 13 Amp plug	11
Figure 7: Drain	12
Figure 8: Example serial number label	17

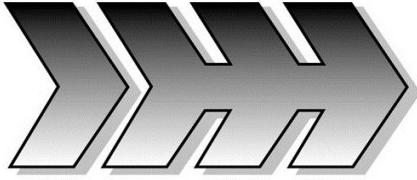

## 2. INTRODUCTION

---

### **Key features and specification**

**Dynawash** has been designed to simulate the conditions necessary to meet the requirements of many leading retail stores standard garment and fabric durability test specifications. Its performance is compatible with the Hoovermatic Twin Tub and other similar devices. Approved by Marks & Spencer plc.

The control fascia incorporates these essential features:

- Digital temperature control. Display resolution 0.1°C
- Digital timer and end of cycle audible and visual alarm
- Display shows minutes and seconds
- Push button tank drainage
- Control Panel is water resistant (IP65 rated)



Other key features include:

- Maximum operating temperature 60°C
- Process bath constructed in stainless steel
- Impeller machined from solid stainless steel
- Interlock immediately stops the stainless steel impeller when lid opened
- Lid damper for added safety and ease of use
- Heating element safety cut-out
- Reinforced bath and bearing housing to eliminate water leakage failures
- Cabinet rated IP23
- Inverter driven motor gives accurate speed control
- Stainless steel impeller rotational speed 560 rpm  $\pm$  2% (speed of impeller is not voltage dependent)
- Easy access through front panel for servicing
- Free standing machine on lockable wheels
- ISO 17025 certificate of calibration
- CE compliant

Electrical specification and requirements:

- 230V  $\pm$  10%, 50-60Hz, single phase, 2750W, 12A

Dimensions :

- Width 670mm x Depth 665mm x Height 840 mm (Height with lid open 1130mm)

Weight :

- 80kg (when empty and excluding packaging)

HEALINK – the Service and Calibration Division of Heal’s – offers a service and calibration contract. Calibration covers impeller speed, temperature and digital timer.

**Dynawash** has been designed to simulate the conditions necessary to meet the requirements of many leading retail stores standard garment and fabric durability test specifications as listed below. **Dynawash is approved by Marks & Spencer and Next.**

### ***Retailer standards***

- M&S C15 Print Durability
- M&S P5 Durability Wash for Garments and Components
- M&S P6 Durability Wash for Pleat Retention
- M&S P7 Durability of Waddings and Quilted Waddings to Washing
- M&S P69 Cockling
  
- NEXT TM 8 Appearance for Garments and Products
  
- BHS TM 12A Durability Wash for Prints and Flock
- BHS TM 12B Durability Wash for Special Effects: Pleats, Crinkle & Seersucker
- BHS TM 12C Appearance Washes for Fused Collars and Cuffs
  
- Arcadia Group CA10a Print Durability for Textiles

### ***National standards***

- BS 7907: 2007 Code of practice for the design and manufacture of children’s clothing to promote mechanical safety

### ***Consumables quick-selector***

		M&S C15	M&S P5	M&S P69	M&S P6	M&S P7	NEXT TM 8	Arcadia CA10a	BS 7907: 2007	BHS TM 12A	BHS TM 12B	BHS TM 12C
<b>DETERGENTS</b>	<b>Stock Code</b>											
Persil Handwash	706-723	J	J	J								
Persil Automatic	706-724		J	J	J	J						
ECE phosphate reference detergent (B)	706-650/1						J	J	J	J	J	J
Sodium Perborate Tetrahydrate <sup>†</sup>							J	J	J	J	J	J
<b>MAKEWEIGHTS</b>	<b>Stock Code</b>											
M&S	702-402	J	J	J	J	J						
ISO (200mm x 200mm)	702-531						J	J	J			
ISO (300mm x 300mm)	702-530									J	J	J
<sup>†</sup> classed as hazardous and not available from Heals												

**Table 1: Consumables by Retailer Standard**

For a full list of applicable Quality Assured Consumables see page 18.

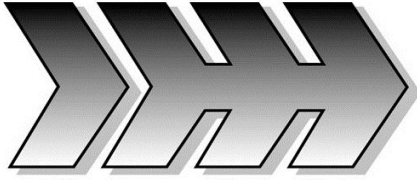

## 3. SAFETY

---

### ***Correct use***

- Dynawash incorporates several safety features to safe-guard the operator. However, hazards may still be encountered if the instrument is operated outside its performance envelope or used inappropriately.
- DO NOT use high pressure water spray on the Control Panel or into the ventilation holes or any other opening on the machine.
- DO NOT completely fill the machine with water. If the impeller is started it will spill out of the bath.
- The process bath is designed for use with water only.

### ***General safety considerations***

- This appliance is heavy (80kg when empty). Care should be taken when moving it.
- It is dangerous to alter the specifications or attempt to modify this product in any way.
- Electrical work required to install this appliance should be carried out by a suitably qualified person.
- Care must be taken to ensure that the appliance does not stand on the electrical supply cable.
- The impeller should not be rotated by hand.
- The impeller will not operate if the lid is opened.
- The maximum operating temperature is 60 °C.
- External surfaces are safe to touch during operation.
- Inspect and clean the lint filter (heater grille) before every use.
- Completely isolate the electrical supply before removing the front or back covers.
- Isolate the electrical supply when testing is completed.

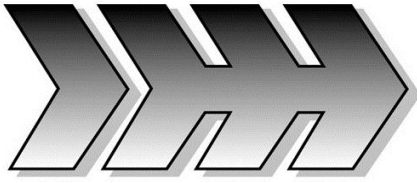

## 4. INSTALLATION

### *Dynawash views and identification of key parts*

**Figure 1: Front view**

1. Gas strut
2. Bath lid
3. Lid hinges
4. Lid lifting handle
5. Control panel
6. Lockable wheels (not shown)

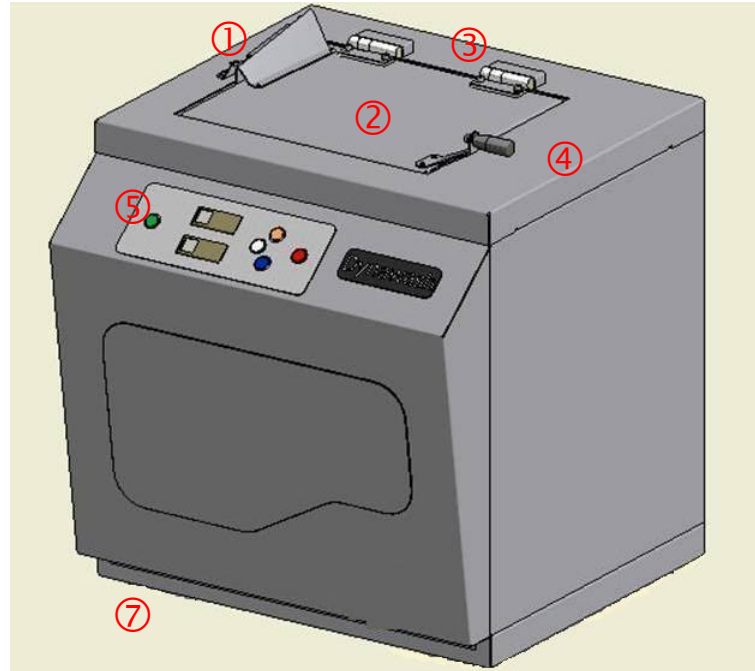

**Figure 2: Top view**

1. Drain hose connection
2. Filling hose connection (with tap)
3. Electrical on/off switch
4. Lid lifting handle

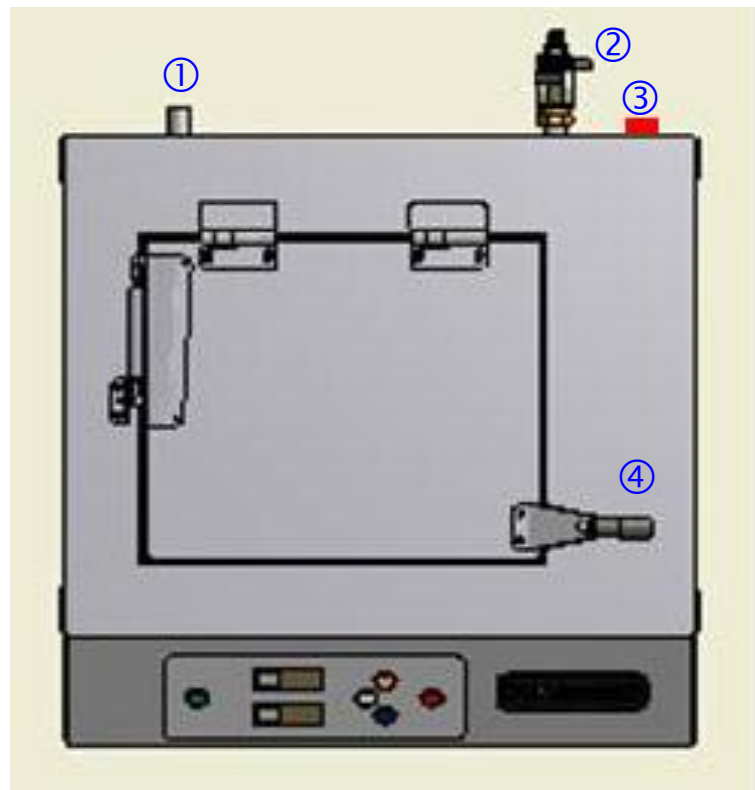

**Figure 3: Process bath**

1. Lid in open position
2. Gas strut keeps lid open
3. Heater grille
4. Fill level marker (approx 40 litres)
5. Stainless steel impeller (rotates clockwise)
6. Fill water inlet

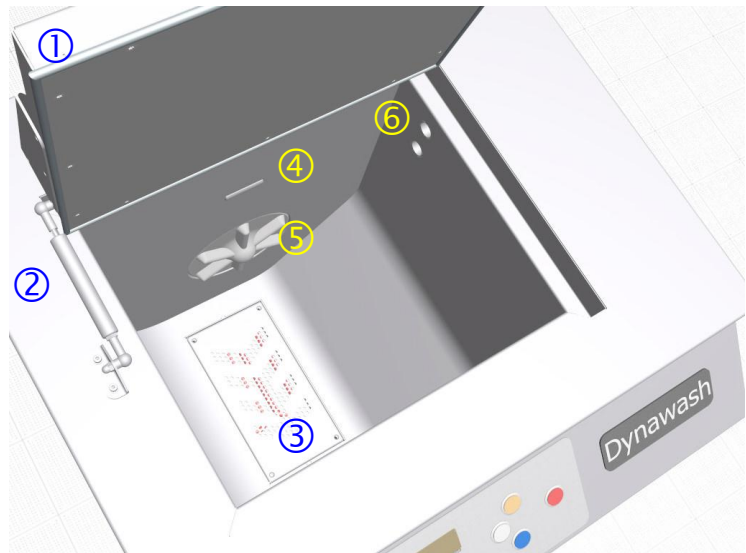

**Figure 4: Sump**

1. Heater grille
2. Stainless steel impeller (rotates clockwise)
3. Sump
4. Coarse filter (not removable)
5. Drain (to pump)

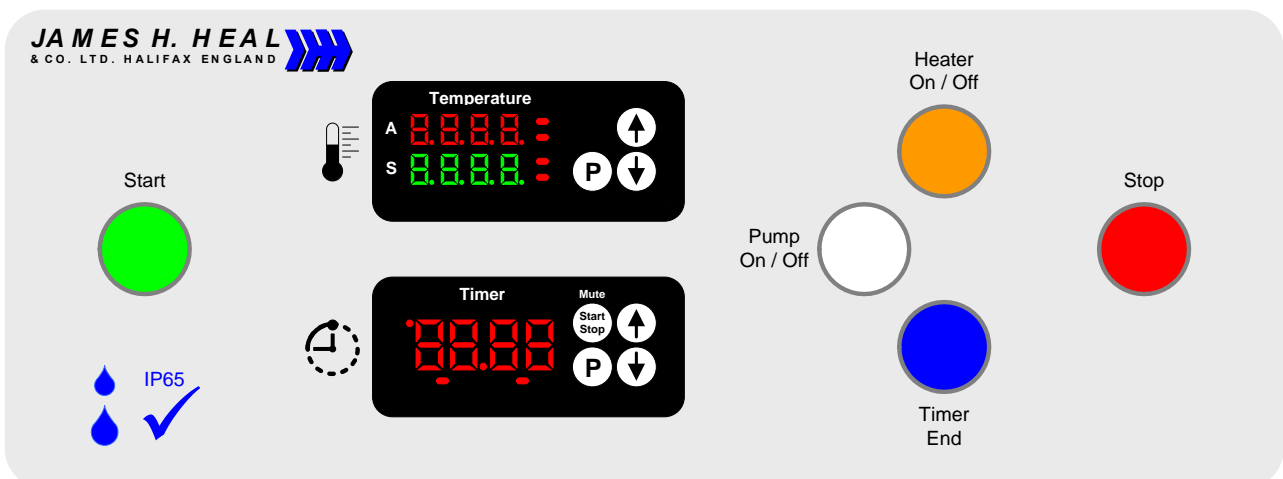
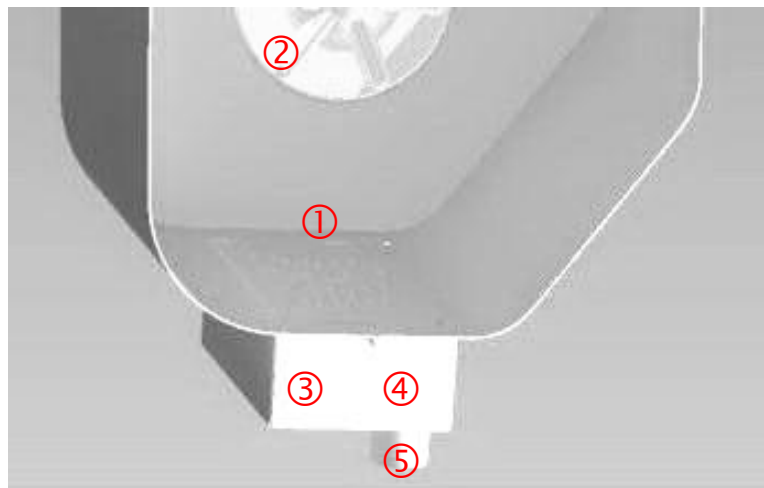

**Figure 5: Dynawash control panel**



## ***Installation safety***

- Before setting up the machine, check it for any externally visible damage. Do not install or use a damaged machine.
- Before connecting the machine, ensure that the connection data on the data plate (voltage and connected load) match the mains electricity supply. If in any doubt, consult a qualified electrician.
- Ensure electrical power is not supplied to the appliance while installation work is being carried out.
- The electrical safety of this machine can only be guaranteed when continuity is complete between it and an effective earthing system which complies with local and national regulations. It is most important that this basic safety requirement is present and regularly tested, and where there is any doubt, the on-site wiring system should be inspected by a qualified electrician. The manufacturer cannot be held liable for the consequences of an inadequate earthing system (e.g., electric shock).
- Do not connect the machine to the mains electricity supply by an extension lead. Extension leads do not guarantee the required safety of the machine (e.g., danger of overheating).
- The machine is built in accordance with current safety requirements. Unauthorised repairs could result in unforeseen dangers for the user, for which the manufacturer cannot accept liability. Repairs should only be undertaken by an approved technician. Ensure electricity is not supplied to the machine until after maintenance or repair work has been carried out.
- In the event of a fault or for cleaning purposes, the machine is only completely isolated from the electricity supply when it is switched off at the wall socket and the plug is withdrawn, or it is switched off at the mains, or the mains fuse is withdrawn.
- Faulty components must only be replaced by genuine original spare parts. Only when these parts are fitted can the safety standards of the machine be guaranteed.

## ***Stainless steel surfaces***

The stainless steel surfaces must not come into contact with liquid cleaning and disinfecting agents which contain chlorides or hypochlorites. These agents can have a corrosive effect on stainless steel. Aggressive vapours containing chlorine can also be corrosive. Do not store containers of these agents on or near the machine.

## ***Packaging***

The transport and protective packing has been selected from materials which are environmentally friendly for disposal and can normally be recycled. Ensure that any plastic wrappings, bags, etc. are disposed of safely and kept out of the reach of babies and young children. Danger of suffocation. Please ensure they are offered for recycling where facilities exist.

Unpack the **Dynawash** carefully and check that the following accessories have been supplied:

- **Dynawash** Durability Wash Tester
  - Drain hose
  - Drain hose clamp
  - Filling hose (blue)
  - Torx Screwdriver
  - Operator's Guide
  - Quick Start Guide
- } You will find these items inside the bath

Do not dispose of any packaging until the instrument has been found to be in good condition, correctly installed and operating correctly.

## ***Services required***

**Dynawash** requires a supply of electricity, a supply of water and a drain facilities. Ensure that the drain and filling hoses are not obstructed or compressed.

## Electrical connection

Any electrical work required to install this appliance should be carried out by a qualified electrician or competent person.

### **WARNING:**

**THIS APPLIANCE MUST BE EARTHED.**

**THE MANUFACTURER DECLINES ANY LIABILITY SHOULD THIS SAFETY MEASURE NOT BE OBSERVED.**

Before switching on, make sure the electricity supply voltage is the same as that indicated on the instrument serial number label.

A 13Amp ASTA approved (BS 1362) fuse must be used. Fit an appropriate type of plug and proceed as in the example described below. The wires in the mains lead are coloured in accordance with the following code:

Green and Yellow	Earth
Blue	Neutral
Brown	Live

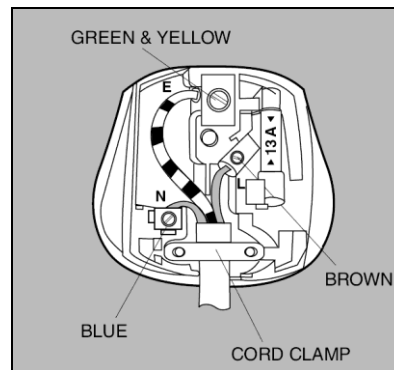

**Figure 6: UK 13 Amp plug**

- The wire coloured green and yellow must be connected to the terminal marked with the letter “E” or by the earth symbol  $\perp$  or coloured green and yellow.
- The wire coloured blue must be connected to the terminal “N” or coloured black.
- The wire coloured brown must be connected to the terminal marked “L” or coloured red.

Upon completion there must be no cut or stray strands of wire present and the cord clamp or similar device must secure the outer insulating sheath.

It is good practice, where an electrically powered machine is operated in close proximity to water, or containing a water supply, to protect the user by fitting a Residual Current Device (RCD) of 30mA sensitivity.

To make a permanent connection it is necessary to install a double pole switch between the instrument and the electricity supply (mains), with a minimum gap of 3mm between the switch contacts and of a type suitable for the required load in compliance with the current electrical regulations. The switch must not break the yellow and green earth cable at any point.

## **Water connection**

The machine should be connected to a mains water supply in accordance with local and national safety regulations. The water inlet is fitted with a non-return valve.

If the water pressure is higher than 1000 kPa (approx 10 bar) it is essential to fit a pressure reducing valve. Using the blue filling hose provided, connect to the mains water supply incorporating a mains stopcock with BSP  $\frac{3}{4}$ " thread. The stopcock should be fitted by a qualified plumber.

The washing machine is suitable for connection to a hot water supply up to 60 °C.

## **Drain connections**

**Dynawash** can be connected permanently to a water supply for filling the process bath. There is a drain connection to empty process bath via the pump.

Ensure that the drain pipe is higher than the water level in the bath to prevent the possibility of siphoning of water from the bath. Use a standpipe or sink to receive the drain water.

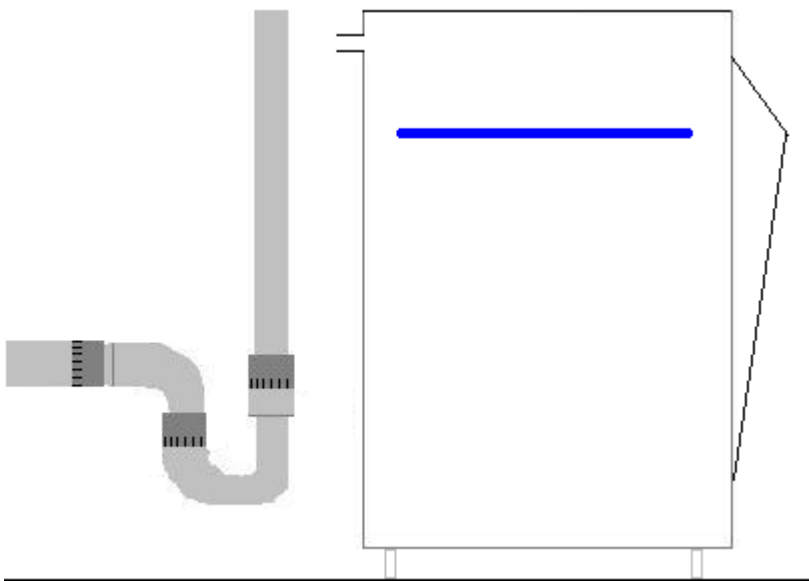

**Figure 7: Drain**

Left hand side of **Dynawash** showing normal water level at fill line and the drain outlet at rear of machine.

The drain is used to pump water from the process bath.

To drain directly into a sink or basin, hook the hose over the edge and secure. Make sure that the water can drain away freely without hindrance. Otherwise there is a risk of water overflowing from the sink or of some of the drained water being sucked back into the machine.

The pump will discharge the 40 litre bath in approximately 90 seconds (0.44 l/s).

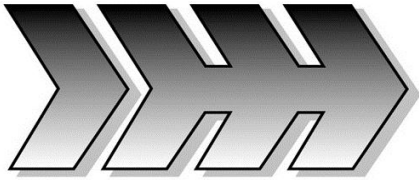

## 5. OPERATION

Before each use, inspect the lint filter and clean if necessary.

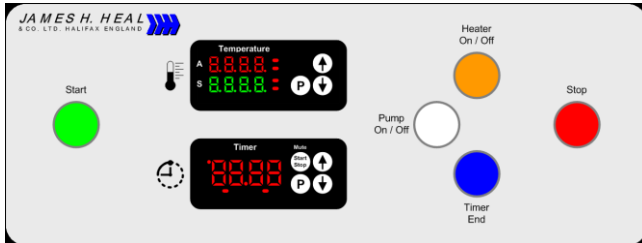

This is the **Dynawash** control panel.

The buttons and indicators are self-explanatory.

Ensure the bath is filled with water to the fill marker (approx. 40 litres).

Switch on the power and the display quickly goes through a self-test.

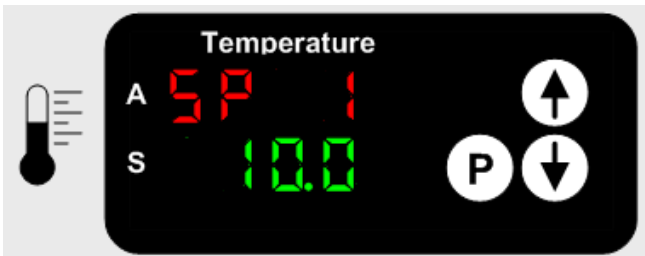

To set the temperature:

Press the **P** button on the Temperature controller.

**SP 1** (set-point) is displayed.

Use the **↑** **↓** buttons to increase or decrease the temperature set-point.

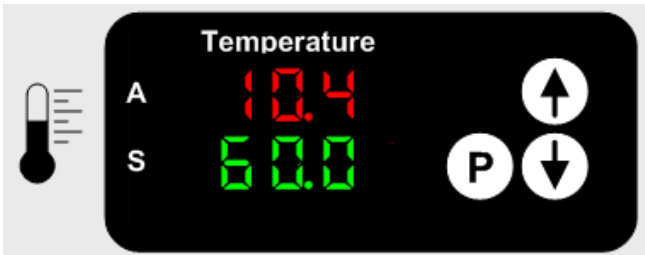

Press the **P** button again to Program the required temperature set-point.

**A** = Actual temperature of water

**S** = temperature **S**et-point







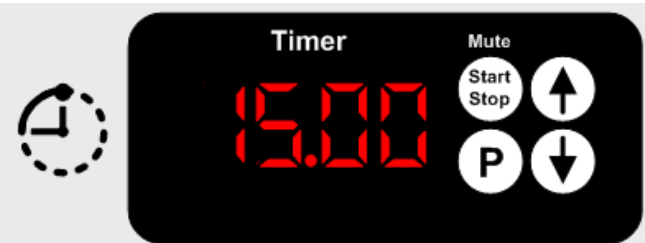

To set the timer:

Press the **P** button on the Timer controller. **t 1** is displayed.

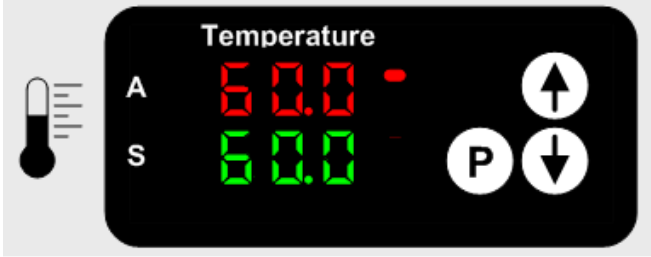

Use the **↑** **↓** buttons to increase or decrease the time.

Press the **Start Stop** button to set the new Timer set-point.

<div style="display: flex; justify-content: space-around;"> <div style="text-align: center;"> <p>Heater On / Off</p>  </div> <div style="text-align: center;"> <p>Start</p>  </div> </div>	<p>Press the <b>Heater</b> button to switch the electric heater on.</p> <p>Press the <b>Start</b> button to start the impeller turning in the water bath.</p> <p><i>Note: the impeller will not start if the lid is open.</i></p> <p><i>Note: always run the impeller while heating.</i></p>
	<p>Prepare specimen, detergent and makeweights as required.</p> <p>When set temperature is achieved, add detergent and run for approx. 1 minute.</p> <p>If required, add makeweights and run for approx. 1 minute.</p>
	<p>Add specimen, close lid and <b>Start</b> impeller.</p> <p>Start the Timer by pressing the <b>Start Stop</b> button on the Timer.</p> <p>The Timer will count down displaying mm:ss.</p> <p>The Timer will count down to zero.</p>
<div style="display: flex; justify-content: space-around;"> <div style="text-align: center;">  <p>Timer End</p> </div> <div style="text-align: center;"> <p>Heater On / Off</p>  </div> </div>	<p>The <b>Timer End</b> indicator will illuminate and the buzzer will sound to alert the operator.</p> <p>The impeller will <b>Stop</b> automatically.</p> <p>To silence the buzzer press the <b>Mute (Start Stop)</b> button on the Timer.</p> <p>Switch the electric heater off by pressing the <b>Heater</b> button.</p>
	<p>Open the lid and remove the specimen first, then remove the makeweights.</p> <p>Rinse and dry the specimen and makeweights, as required.</p>
<div style="text-align: center;"> <p>Pump On / Off</p>  </div>	<p>To empty the bath, ensure the heater is off.</p> <p>Press the <b>Pump</b> button to drain the bath. This will take approx. 90s.</p> <p>When the bath is empty, rinse with clean water while the pump is running.</p> <p>When the bath is empty switch the <b>Pump</b> off.</p> <p>Wipe the exterior of <b>Dynawash</b> with a soft dry cloth.</p>

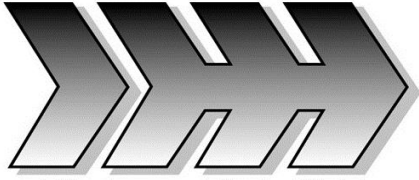

## 6. CLEANING

---

### ***General cleaning***

Rinse the bath with clean water to remove residual lint and detergent.

**DUE TO THE AGGRESSIVE NATURE OF THE DURABILITY TESTS, THE TEST SPECIMENS MAY PRODUCE LINT AND LOOSE THREADS WHICH WILL COLLECT IN THE SUMP. PERIODICALLY INSPECT THE SUMP AND REMOVE ANY COLLECTED LINT, THREADS OR OTHER DEBRIS. THIS SHOULD BE CARRIED OUT AT LEAST WEEKLY INTERVALS. MORE FREQUENT CLEANING MAY BE REQUIRED IF THE MATERIALS UNDER TEST ARE PRONE TO SHEDDING FIBRES AND/OR THREADS.**

**CAUTION:  
WHEN REMOVING THE HEATER GRILLE (SUMP COVER/LINT FILTER) CARE SHOULD BE TAKEN AS THE HEATING ELEMENT IS LOCATED IN THE SUMP. SWITCH OFF THE HEATER AND ISOLATE FROM THE ELECTRICAL SUPPLY.**

To access the sump filter remove the four (4) screws which secure the heater grille using the Torx screwdriver provided and lift out the heater grille. The small round sump filter is not removable.

Remove any material which has been accumulated by hand or using a small brush, do not use metal implements which may damage the coarse filter or the heater.

Ensure the heater grille is replaced with all four (4) screws before reconnecting the electrical supply.

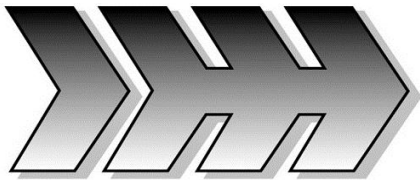

## 7. TROUBLE SHOOTING

---

Certain problems are due to lack of simple maintenance or oversights which can be solved easily without calling out an engineer. Before contacting your HEALINK or Technical Support, please carry out the checks listed below:

### ***Electrical problems***

The Control Panel is not illuminated:

- Check the machine is connected to the electricity supply and that it is switched on.
- Check that the RCD at the supply has not tripped. Reset if required.
- Check the isolator switch on the rear of the machine is in the on position.

Heater does not work:

- If the thermal / heater cut-out has activated (for example, when the heater has been switched on with no water in the bath), switch the machine off and wait for 30 minutes. Fill with water then switch the machine back on again.

### ***Mechanical problems***

If the impeller is not rotating:

- Isolate the electricity supply, remove the back cover, check the belt is connected to the pulleys and the belt tension is correct.

The pump does not drain the bath:

- Check the sump for debris, check the drain hose is not compressed or blocked.

### ***Healink contacts***

HEALINK is a totally comprehensive, worldwide support programme. When you buy instrumentation from us, it is the beginning rather than the end of an association. Our aim is simple: to provide precisely the services you need to maintain and protect the value of your investment.

Please fax or e-mail any enquires you may have regarding your instrument to the HEALINK Manager. If reporting a fault please give a detailed description of the problem and how it occurred. When contacting HEALINK or ordering Spare Parts always quote the full Serial Number as shown in the diagram below (page 17).

Fax: +44 (0)1422 352440

Email: [support@james-heal.co.uk](mailto:support@james-heal.co.uk)



## How to order spare parts

When ordering Spare Parts or contacting HEALINK always quote the full Serial Number as shown in the diagram below, followed by the stock code and description of the part required.



Figure 8: Example serial number label

## Spare parts list

Stock code	Description
133-123	Tubular Heating Element
195-236	Temperature Sensor
195-237	Compression Gland
195-240	Lock Nut
130-854	Fuse Ultra Rapid
130-852	Fuse 100 mA Semi Delay
130-825	Fuse 1A 20mm Antisurge
130-820	Fuse 5A Antisurge
130-848	Fuse 250mA 20mm Antisurge
527-035	Bearing Assembly
387-402	V Belt
327-213	Drain hose
393-549	Hose clamp
779-208	Water inlet hose (blue)
381-721	Torx screwdriver

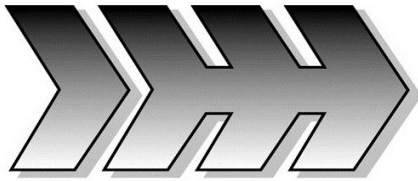

## 8. CONSUMABLES

---

Stock Code	Accessories
------------	-------------

766-200	HEAL'S Grey Scale for assessing Change in Colour ISO 105 A02
---------	--

766-201	HEAL'S Grey Scale for assessing Staining ISO 105 A03
---------	--

Detergents	
------------	--

706-723	Persil ( <i>not</i> automatic) - per pack (approx. 900g)
---------	--

706-724	Persil Heavy Duty, Low Lather (automatic, non-biological) - per pack (approx. 3 kg)
---------	---

706-650	HEAL'S ECE Formulation Phosphate Reference Detergent (B) - per tub (2kg)
---------	--

706-651	HEAL'S ECE Formulation Phosphate Reference Detergent (B) - per box (15kg)
---------	---

203-919	<i>Certificate of Conformity for HEAL'S ECE Reference Detergent (B)</i>
---------	---

Makeweights	
-------------	--

702-402	M & S Polyester Makeweights - per pack (1 kg) Size : 220 x 220 + 5mm Weight: 50 + 5g
---------	--

203-928	<i>Certificate of Conformity for M &amp; S Makeweights</i>
---------	--

702-530	HEAL'S ISO Polyester Makeweights - per pack ( 1kg)
---------	--

Complies with BS EN 26330: 1994, ISO 6330: 1984 and Next

203-926	<i>Certificate of Conformity for HEAL'S ISO Makeweights 702-530</i>
---------	---

702-531	HEAL'S ISO Polyester Makeweights - per pack (1 kg)
---------	--

Complies with BS EN ISO 6330: 2001 (EN ISO 6330: 2000)

203-927	<i>Certificate of Conformity for HEAL'S ISO Makeweights 702-531</i>
---------	---

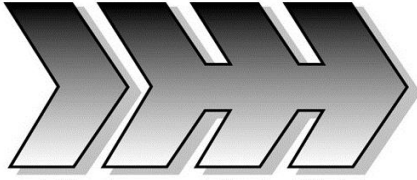

## 9. CE COMPLIANCE

---

### ***CE compliance statements***



MACHINERY DIRECTIVE (98/37/EC)

Implemented in the UK through the following:

Supply of Machinery (Safety) Regulations 1992

(SI 1992 No. 3073)

Supply of Machinery (Safety) (Amendment) Regulations 1994

(SI 1994 No. 2063)

Supply of Machinery (Safety) (Amendment) Regulations 2005

(SI 2005 No. 831)

LOW VOLTAGE DIRECTIVE (73/23/EEC)

Implemented in the UK through the following:

Electrical Equipment (Safety) Regulations 1994

(SI 1994 No. 3260)

ELECTROMAGNETIC COMPATIBILITY (EMC) DIRECTIVE (89/336/EEC)

( see Note 1 below )

Implemented in the UK through the following:

Electromagnetic Compatibility (EMC) Regulations 2005

(SI 2005 No. 281)

---