



JAMES H. HEAL
& COMPANY LIMITED

**WRINKLE RECOVERY
TESTER
MODEL 155**

OPERATOR'S GUIDE

James H. Heal & Co. Ltd.
290-155B

Publication



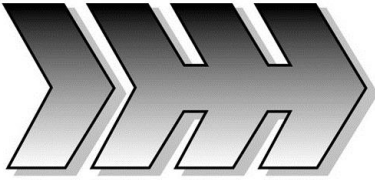

James H. Heal & Co. Ltd. Richmond Works, Halifax, England!



Founded in 1872

Published by: -

JAMES H. HEAL & CO. LTD.
RICHMOND WORKS
HALIFAX
WEST YORKSHIRE HX3 6EP
ENGLAND

TELEPHONE +44 (0) 1422 366355

FACSIMILE +44 (0) 1422 352440

E-mail info@james-heal.co.uk

Internet <http://www.james-heal.co.uk>

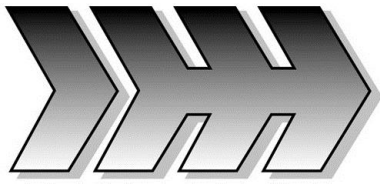

TABLE OF CONTENTS

1.	INTRODUCTION	.	.	.	4
2.	INSTALLATION	.	.	.	5
3.	IDENTIFICATION OF PARTS	.	.	.	6
4.	ASSEMBLY	.	.	.	7
5.	DETAILED OPERATION	.	.	.	8
6.	MAINTENANCE	.	.	.	11
7.	SPARES AND CONSUMABLES	.	.	.	12
8.	HEALTH & SAFETY	.	.	.	13



1. INTRODUCTION

PURPOSE

The **Wrinkle Recovery Tester** is used to determine the appearance of textile fabrics after induced wrinkling.

SCOPE

In compliance with the requirements of AATCC 128, ENKA 3061, ISO 9867 and M & S P123.

It is applicable to woven and knitted fabrics made from any fibre or combination of fibres, particularly those for outerwear and lightwear fabrics containing wool or wool blends. Materials which are insufficiently stable to carry a defined crease such as limp, thick or those with a tendency to curl, can be assessed for wrinkle resistance with this device.

Conditioned specimens are wrinkled under specified conditions, i.e. temperature, relative humidity, load and time. Their appearance is then evaluated against three-dimensional reference standards or photographic standards.

A specimen is cut and wrapped, face outwards, around the upper and lower flanges of the instrument. Steel springs are used to clamp the specimen to the flanges. Wrinkling is induced by withdrawing a locking pin, which allows the upper flange to fall. As it falls it spirals around the central pillar, distorting the fabric, before coming to rest on the lower flange.

Dependent on the test method, different combinations of weights are applied to the resting top flange. After the prescribed period, the specimen is carefully and gently removed. After a further recovery period, it is assessed against the appropriate reference standard.

The right is reserved to alter the specification or modify the appearance without notice.

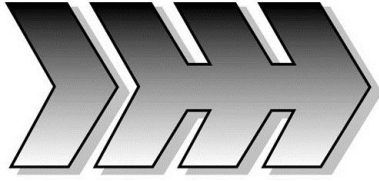

2. INSTALLATION

UNPACKING

- Check all packaging and contents from the case.

Do not dispose of any packaging material until all items are accounted for.

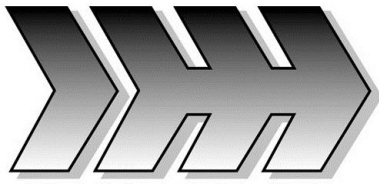

3. IDENTIFICATION OF PARTS

The following is a list of items which are available for use with the **Wrinkle Recovery Tester**.

The items received will vary according to the requirements of each customer.

- Check the items against the original order.
- Please notify the manufacturer immediately in the event of discrepancies.

Weight Set (AATCC & ISO)

1 x 0.2 kg (addition to top flange)
1 x 0.5 kg
1 x 1.0 kg
1 x 2.0 kg

Weight Set (ENKA)

1 x 0.5 kg
2 x 2.0 kg

Weight Set (M & S)

1 x 1.5 kg

3-D Wrinkle Recovery Replicas (AATCC and ISO)

3-D Wrinkle Recovery Replicas (M & S)

Set (8) Photographic Standards (ENKA)

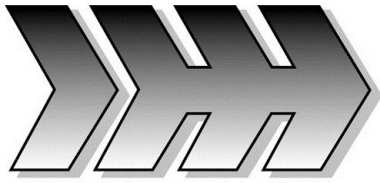

4. ASSEMBLY

- Place the **Wrinkle Recovery Tester** and accessories on a suitable bench.
- The general assembly is outlined below.

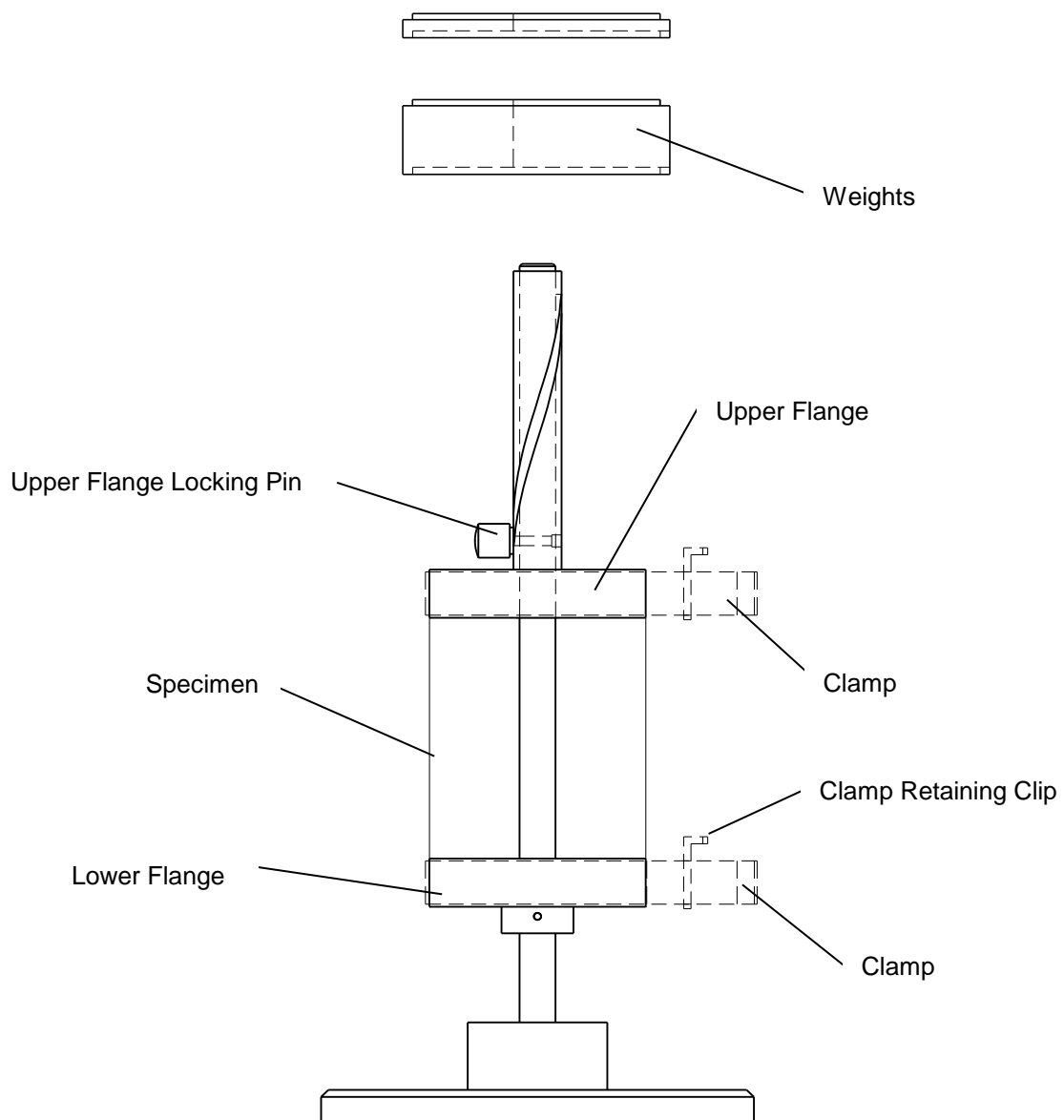
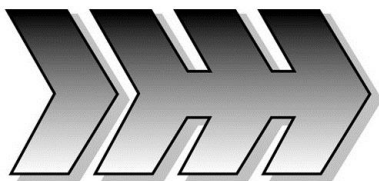

FIGURE 1



5. DETAILED OPERATION

GENERAL

Wrinkle recovery can be determined under different atmospheric testing conditions.

For AATCC 128, ISO 9867 and M & S P123 please refer to the appropriate standard for precise details of each test method.

The following describes the ENKA AG test methods 3061 A and 3061 B.

METHOD 3061 A

1. Enka 3061 A relates to testing in the standard atmosphere for testing textiles at $20 \pm 2^{\circ}\text{C}$ and $65 \pm 2\%$ r.h.
2. Cut rectangular specimens 145 x 300mm in both the warp and weft direction for woven fabrics and wale and course for knitted.
3. Condition the specimens for 24 hours in the standard atmosphere specified at (1).
4. Ensure the top flange of the instrument is secured in its uppermost position by means of the locking pin.
5. Mount a test specimen, face side on the outside by wrapping one long edge evenly around the top flange and securing it with one of the steel clamps provided. Use the V shaped clip to fasten the ends of the clamp together.
6. Wrap the lower long edge of the specimen around the bottom flange evenly and secure it with the second steel clamp.
7. Adjust the specimen as necessary so that the cylinder of fabric formed lies smooth and even around the flanges. Pull on the bottom edge of the specimen to eliminate any sagging between the flanges.
8. Withdraw the top locking pin and lower the top flange gently with one hand until it comes to rest.
The upper flange will spiral downwards through 180° thereby distorting the specimen.
9. Immediately place the 2 x 2kg weights on the top flange, thus compressing the specimen. Leave the weights in situ for 20 minutes.
10. After this period of time has elapsed, remove the weights and return the upper flange to its uppermost position, secured with the locking pin.
11. Remove both steel clamps and carefully take the specimen and suspend it freely from its short edge for the visual assessment of wrinkle recovery in the standard atmosphere.

12. Wrinkle recovery is assessed against a set of photographic standards 1-8 where 1 is the worst case gradually diminishing to a flawless 8.
13. For an overall rating of wrinkle recovery, the assessment is repeated after different recovery periods, for example:
 - CR0 - Immediately after removal from instrument.
 - CR1 - After 1 hour.
 - CR2 - After 2 hours.
 - CR24 - After 24 hours.
14. At least 2 tests should be carried out on specimens cut in each fabric direction:
 - 2 Warp and 2 Weft (Woven)
 - 2 Wale and 2 Course (Knitted)

METHOD 3061 B

1. Enka 3061 B relates to testing in an environmental chamber set to $35 \pm 2^{\circ}\text{C}$ and $85 \pm 3\%$ r.h
2. Cut rectangular specimens 145 x 300mm in both the warp and weft direction for woven fabrics and wale and course for knitted.
3. Ensure the top flange of the instrument is secured in its uppermost position by means of the locking pin.
4. Mount a test specimen, face side on the outside by wrapping one long edge evenly around the top flange and securing it with one of the steel clamps provided. Use the V shaped clip to fasten the ends of the clamp together.
5. Wrap the lower long edge of the specimen around the bottom flange evenly and secure it with the second steel clamp.
6. Adjust the specimen as necessary so that the cylinder of fabric formed lies smooth and even around the flanges. Pull on the bottom edge of the specimen to eliminate any sagging between the flanges.
7. Place the instrument complete with specimen in the environmental chamber for 1 hour to condition.
8. Remove the instrument from the environmental chamber and withdraw the top locking pin and lower the top flange gently with one hand until it comes to rest. The upper flange will spiral downwards through 180° thereby distorting the specimen.
9. Immediately place the 0.5 kg weight on the top flange thus compressing the specimen. Leave the weight in situ for 10 minutes.
10. After this period of time has elapsed, remove the weights and return the upper flange to its uppermost position, secured with the locking pin.
11. Remove both steel clamps and carefully take the specimen and suspend it freely from its short edge for the visual assessment of wrinkle recovery in the standard atmosphere.

12. Wrinkle recovery is assessed against a set of photographic standards 1-8 where 1 is the worst case gradually diminishing to a flawless 8.
13. For an overall rating of wrinkle recovery, the assessment is repeated after different recovery periods, for example:
 - CR0 - Immediately after removal from instrument.
 - CR1 - After 1 hour.
 - CR2 - After 2 hours.
 - CR24 - After 24 hours.
14. At least 2 tests should be carried out on specimens cut in each fabric direction:
 - 2 Warp and 2 Weft (Woven)
 - 2 Wale and 2 Course (Knitted)

IMPORTANT NOTE:-

For carrying out tests to AATCC 128, ***the 0.2kg weight must be placed on the top flange and remain in situ for all testing to this standard.***

This is to compensate for the difference in weight of the top flange between the Enka method and AATCC.

i.e. ENKA = 300g and AATCC = 500g

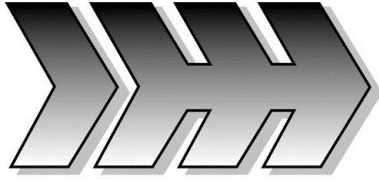

6. MAINTENANCE

- i. Keep the instrument and accessories clean.
- ii. No further maintenance is required.

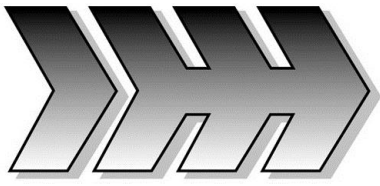

7. SPARES AND CONSUMABLES

Weight Set (AATCC & ISO)

780-894	1 x 0.2 kg	(addition to top flange)
	1 x 0.5 kg	
	1 x 1.0 kg	
	1 x 2.0 kg	

Weight Set (ENKA)

780-895	1 x 0.5 kg
	2 x 2.0 kg

Weight Set (M & S)

780-896	1 x 1.5 kg
---------	------------

766-494 3-D Wrinkle Recovery Replicas (AATCC and ISO)

766-497 3-D Wrinkle Recovery Replicas (M & S)

766-498 Set (8) Photographic Standards (ENKA)

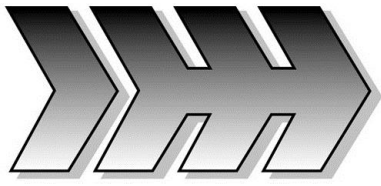

8. HEALTH & SAFETY

MATERIAL DATA

SPECIFIC RISKS: NONE