

INCH-POUND

MIL-PRF-13830B
9 January 1997
SUPERSEDING
MIL-O-13830A
11 September 1963

PERFORMANCE SPECIFICATION

OPTICAL COMPONENTS FOR FIRE CONTROL INSTRUMENTS; GENERAL SPECIFICATION GOVERNING THE MANUFACTURE, ASSEMBLY, AND INSPECTION OF

This specification is approved for use by all Departments and Agencies of the Department of Defense.

1. SCOPE

1.1 Scope. This specification covers the manufacture, assembly, and inspection of finished optical components such as lenses, prisms, mirrors, reticles, windows and wedges for fire control instruments.

2. APPLICABLE DOCUMENTS

2.1 General. The documents listed in this section are needed to meet the requirements specified in sections 3, 4, and 5 of this specification. This section does not include documents in other sections of this specification or recommended for additional information or as examples. While every effort has been made to ensure the completeness of this list, document users are cautioned that they must meet all requirements documents cited in sections 3, 4, and 5 of this specification, whether or not they are listed.

Beneficial comments (recommendations, additions, deletions) and any pertinent data which may be of use in improving this document, should be addressed to: Commander, U.S. Army ARDEC, ATTN: AMSTA-AR-EDE-S, Picatinny Arsenal, New Jersey 07806-5000 by using the Standardization Document Improvement Proposal (DD Form 1426) appearing at the end of this document or by letter.

AMSC N/A

FSC 6650

DISTRIBUTION STATEMENT A. Approved for public release; distribution is unlimited.

2.2 Other Government documents, drawings, and publications. The following other Government documents, drawings, and publications form a part of this document to the extent specified herein. Unless otherwise specified, the issues are those cited in the solicitation.

DRAWINGS

US ARMY ARMAMENT RESEARCH, DEVELOPMENT AND ENGINEERING CENTER (ARDEC)

C7641866 - Surface Quality Standards for Optical Elements

(Copies of other Government documents, drawings, and publications required by contractors in connection with specific acquisition functions should be obtained from the contracting activity or as directed by the contracting activity.)

2.3 Order of precedence. In the event of a conflict between the text of this document and the references cited herein, the text of this document takes precedence. Nothing in this document, however, supersedes applicable laws and regulations unless a specific exemption has been obtained. (See contract provisions for additional precedence criteria.)

3. REQUIREMENTS

3.1 General. All optical elements, components and systems shall comply with the requirements of this specification, except as further defined in the detailed instrument specification or on applicable drawings forming a part of the contract.

3.2 Materials. Materials shall be in accordance with applicable specifications or component or instrument drawings.

3.2.1 Glass, optical. Optical glass shall be of type and grade specified on the drawings. On authorization to use glass other than that specified, complete information regarding the optical characteristics of the glass and design data shall be furnished to the contracting officer.

3.2.1.1 Radioactive material. Optical glass specified herein shall contain no thorium or other added radioactive material in excess of 0.05 percent by weight.

3.2.2 Adhesive. Unless specified by the contract or order, optical cement shall be in accordance with Appendix A.

3.2.3 Bonding system. Bonding system for glass to metal bonding shall be in accordance with Appendix D.

3.2.4 Sealing compound. Sealing compound shall be in accordance with Appendix E.

3.2.5 Reflection reducing film. Reflection reducing film required for coating of specified optical surfaces shall be in accordance with Appendix C.

3.2.5.1 Reflecting surfaces . Aluminized reflecting surfaces shall be in accordance with Appendix B.

3.3 Mechanical dimensions. Optical elements shall conform to the mechanical dimensions and optical data specified on the drawings or in the contract.

3.3.1 Rim edges. Rim edges of all optical parts shall have a chamfer of 0.020 inch - 0.010 at 45 degrees \pm 15 degrees as measured along the face width unless otherwise specified by the drawing. Edges meeting at angles of 135 degrees and larger need not be beveled unless specified by the drawings.

3.4 Finish and defects. Finish and defects of the optical glass shall conform with requirements of this specification or as indicated on applicable drawings or optical diagrams.

3.4.1 Glass defects. Striae, cords, ream, bubbles, seeds, strain, laps, folds in pressings, or any other defect located in such a point, plane, or position as to impair the performance of the element shall be cause for rejection of that element.

3.5 Optical glass surface quality.

3.5.1 Optical drawings and diagrams. Component optical drawings shall indicate surface quality, and optical system diagrams shall indicate the diameter of an axial beam of rays.

3.5.1.1 Designation of defect size. Limiting sizes of surface defects shall be designated on the drawings by two numbers which refer to two graded sets of surface quality standards per Drawing C7641866. The first number shall refer to scratches and the second number shall refer to digs (see 6.3).

3.5.2 Scratches.

3.5.2.1 Circular element. The combined length of maximum size scratches

located on each surface of an optical element shall not exceed one quarter the diameter of that element.

3.5.2.1.1 Maximum combined lengths of scratches. When a maximum size scratch is present, the sum of the products of the scratch numbers times the ratio of their length to the diameter of the element or appropriate zone shall not exceed one half the maximum scratch number. When a maximum size scratch is not present, the sum of the products of the scratch numbers times the ratio of their length to the diameter of the element or appropriate zone shall not exceed the maximum scratch number.

3.5.2.2 Noncircular shaped element. The computing diameter of element shapes other than circular shall be that of a circle of equal area. Scratches beyond the free aperture of any element as given on the optical system drawings or detail drawings shall not be considered when applying the appropriate formula specified in 3.5.2.1.1.

3.5.2.2.1 True roof surfaces on prisms. True roof surfaces on prisms shall be considered equivalent to a single surface equal to the sum of the individual roof areas for purposes of scratch and dig computation, except that the roof edge shall not be considered in the summation of the length of the allowable scratches. Scratch and dig tolerances for roof prisms are set on the basis that the equivalent surface above is viewed from the air side. (3.7.10.1).

3.5.2.2.2 Surface quality, central zone. Areas of surfaces whose specified scratch qualities are 20 or better shall have no more than 4 separate scratches in any 1/4-inch diameter circular area. This requirement does not apply for scratches smaller than number 10.

3.5.2.3 Surface quality, outer zone. Surface quality outside the free aperture of any element shall be considered 80-50, unless otherwise required.

3.5.2.4 Coating scratches. Coating scratches, scratches which do not penetrate the glass surface, shall be within the same limits specified in 3.5.2. Coating scratches shall be considered separate from the substrate scratch requirements.

3.5.3 Digs.

3.5.3.1 Dig designation. Dig numbers are the actual diameters of defects allowed, specified in units of 1/100mm. In the case of irregular shaped digs the diameter shall be taken as the average of the maximum length and maximum width.

3.5.3.2 Maximum size digs. The permissible number of maximum size digs shall be one per each 20mm of diameter or fraction thereof on any single optical surface. The sum of the diameters of all digs as estimated by the inspector shall not exceed twice the diameter of the maximum size specified per 20mm diameter. Digs less than 2.5 microns shall be ignored.

3.5.3.3 Surface quality. All digs on each surface whose dig quality is number 10 or smaller shall be separated edge to edge by at least 1mm. The measurement of scattering shall not be required for surfaces where digs larger than number 10 are allowed.

3.5.4 Bubbles and inclusions. Bubbles shall be classed as surface digs. Any inclusion in the glass shall be treated as a bubble. The size of irregular shaped inclusions shall be considered as one half the sum of the maximum length and the maximum width. Bubble size tolerances are identical in all respects to digs; but the bubble tolerance, is in addition to the dig tolerance.

3.5.4.1 Maximum size bubbles. The permissible number of maximum size bubbles shall be one per 20mm of light path, or fraction thereof, of any single element. The sum of the diameters of all bubbles as estimated by the inspector shall not exceed twice the diameter of the maximum size specified per 20mm diameter for each 20mm of light path. When surface dig quality is 10 or smaller, bubbles shall follow requirements for digs as specified in 3.5.3.3.

3.5.5 Limiting size of surface defects. If not specified on drawings, the limiting size of scratches or digs shall be determined from Table I and is based on the beam diameter of magnification.

3.5.5.1 Beam diameter of magnification. The beam diameter shall be obtained from the optical data. It is the diameter at the surface of the optic in question, of a bundle of axial rays proceeding to the observer's eye. The diameter of the bundle at the eye shall be taken as 3.5mm, (0.1378 inch) if the exit pupil is over 3.5mm. If the exit pupil is smaller than 3.5mm, that diameter of the bundle at the eye shall be the same as the exit pupil.

3.5.5.2 Beam size less than in table I. When the beam size is less than that specified for focal planes and near local planes of any surface, the size of defect is determined by the magnification of the eyepiece multiplied by magnification of the erecting system.

3.5.5.3 Zone. The surface on which the beam diameter of an axial bundle is 25 percent or less of the free aperture shall be divided into a central and outer zone. The central zone shall be half the free aperture in width. Zone size for reticles shall be as specified in 3.7.11.1.

3.6 Cement defects. Cement bubbles, voids, undissolved particles, dry spots, blisters, dirt (lint or dust) within the free aperture of the cemented lens shall not exceed the limits of defects for digs and bubbles specified in 3.5.3.1 thru 3.5.4.1 inclusive.

TABLE I Surface Quality Requirements

Focal planes and near focal planes			Central zone 1/2 diameter of surface		Outer Zone	
Beam diameter (mm)	Magnifying power	Focal length (mm)	Scratch	Dig	Scratch	Dig
Over 5.....	80	50	80	50
4-5.....	60	40	60	40
3.2-4.....	60	30	60	40
2.5-3.2	40	20	60	40
2.1-2.5.....	40	15	60	30
1.6-2.1.....	30	10	40	20
1.0-1.6.....	20	5	40	15
0.6-1.0.....	15	3	30	10
0.4-0.6.....	10	2	20	5
0.2-0.4.....	10	1	15	3
0.2.....	20-10	12.5-25	10	1	15	3
0.4.....	10-5	25-50	10	2	20	5
0.6	5-3.3	50-75	15	3	30	10
1.0.....	3.3-2	75-125	20	5	40	15
1.6.....	2-1	125-250	30	10	40	20

3.6.1 Surface quality of cemented face. Cement defects inside the free aperture shall be considered on the basis that the cement interface is a single surface of the specified surface quality. When not specified, the surface quality for a cement face shall be intermediate between that of adjacent faces.

3.6.2 Edge separations. Edge separation and edge cement defects in optical components shall not extend beyond the edge chamfer of the cemented surface of the lens or prism by the distance greater than 1/2 the distance between the cemented surface chamfer of the component and the radius of the clear aperture. The maximum dimension of any edge separation or cement defect shall not extend into the cemented surface of the component by more than 1mm. The sum of the edge separations or cement defects larger than 1/2mm as measured at the surface chamfer of the lens or prism, shall not exceed 10 percent of the perimeter.

3.6.3 Bonding defects (glass to metal). Bonded optical assemblies shall have a continuous bead of the cured adhesive along the edge of the bonded surface.

3.6.3.1 Void and separations. Subsequent to meeting the requirements of 3.7.2 and 3.8.2.5.2, there shall be no voids or separations that exceed 10 percent of the bonded area.

3.7 Optical component details.

3.7.1 Temperature operation. Cemented components as a result of exposure to ambient air temperatures of minus 80 ± 2 degrees and plus 160 ± 2 degrees F shall not develop "feathering", show evidence of separation or softening of cement or other defect, except as specified in 3.6, with the provision that the increase or development of edge separation or edge cement defects shall be cause for rejection.

3.7.2 Relative humidity - temperature operation. Cemented components as a result of exposure to an ambient atmosphere of plus 130 ± 2 degrees F temperature, and at least 95 percent minimum relative humidity, and subsequent exposure to ambient air temperature of minus 80 ± 2 degrees and plus 160 ± 2 degrees F, shall not develop "feathering", show evidence of separation or softening of cement or other defects, except as specified in 3.6.

3.7.3 Reflection reducing films. Optical surfaces specified on drawings as "surfaces to be coated" shall be coated with a reflection reducing film (see 3.2.5).

3.7.4 Optical blackening. When specified, ground surfaces of optical elements shall be blackened with a finish approved by the responsible technical activity.

3.7.5 Resolution. Resolution tests shall be performed on each objective, collective, erector, eyepiece, mirror, wedge, window, filter, prism and prism assembly (optical) as specified in 4.2.5.

3.7.6 Parallelism, filters. Parallelism of filters shall be within the tolerance specified on the drawings. When no tolerance is specified, filters located internally or in front of a telescope shall not exceed 1 minute of arc light deviation. Filters located between the eyelens and the exit pupil shall not have a light deviation exceeding 5 minutes of arc.

3.7.7 Reticle scale spacing. Reticle scale spacing shall be tested in accordance with 4.2.10.5.

3.7.8 Polished surfaces. Polished surfaces shall show no evidence of grayness or stain when inspected in accordance with 4.2.2.

3.7.9 Lenses.

3.7.9.1 Surface quality. Surface quality of each lens shall be in accordance with applicable drawings or instrument specifications. When not specified, the surface quality shall be as follows: Objectives, erectors, windows and other elements which lie at least fifteen diopters out of the focal plane, shall have a surface quality of 80-50 or

better. Field and collective lenses shall have a surface quality of 20-5 in the central zone and 40-15 in the outer zone. Center lenses of oculars shall have a surface quality of 40-15 in the central zone and 40-20 in the outer zone. Eyelenses, excepting those in symmetrical eyepieces, shall have a surface quality of 40-20 in the central zone and 60-30 in the outer zone. When the field and eyelens are identical, the surface quality for both shall be 20-5 in the central zone and 40-15 in the outer zone.

Filters which lie between the eyelens and the exit pupil shall have a surface quality of 40-20 in the central zone and 60-30 in the outer zone. Filters which lie internally shall have the same requirements as specified for prisms in 3.7.10.1. Filters located in front of the objective shall have a surface quality of 80-50 or better.

3.7.9.2 Fractures and edge chips. Edge chips which do not encroach on the free aperture of the lens shall be allowable, providing the chip does not interfere with the sealing of the lens in the mount. The surface of all chips larger than 1/2mm, as measured at the largest extremities, shall be "stoned" to roughen it and lessen the possibility of annoying reflections and additional chipping. The sum of the chip widths of chips larger than 1/2mm, as measured at the edge of the lens, shall not exceed 30 percent of the perimeter. Fractures in any face or edge shall be ground out.

Ground out areas shall remain within the applicable stoned chip limits of this paragraph. Stoned chips and fractures in ground faces whose total summed up areas are in excess of 2 percent of the area of the ground face or which are in excess of 2mm depth shall be cause for rejection. Such stoned chips and fractures shall be cause for rejection when they interfere with the optical path, mounting or sealing methods regardless of their size.

3.7.9.3 Concentricity. Edges of all elements shall be trued to diameter about the optical axis as a center by grinding. Lenses composed of two or more elements shall be cemented and centered in such a manner that the axis of each element coincides with the axis or axes of the other element or elements. Ocular lenses shall be concentric within 6 minutes or arc, and all other lenses shall be concentric within 3 minutes of arc unless otherwise specified on the drawing or in item specifications. After centering and cementing, mechanical eccentric glass overhang in excess of 50 percent diameter tolerance shall be removed. Optical eccentricity is defined as the angular deviation, after refraction of an incident ray which is coincident with the geometric axis of the lens.

3.7.10 Prisms and mirrors.

3.7.10.1 Surface quality. Surface quality of each prism shall be in accordance with applicable drawings or instrument specifications. For surfaces which lie at least 15 diopters out of the focal plane, quality shall be 80-50 or better. For surfaces which lie within 5 to 15 diopters of the focal plane the surface quality shall be 20-5 for the central zone and 40-15 for the outer zone. For surfaces which lie within 5 diopters of the focal plane surface quality shall be the same as for reticles.

3.7.10.2 Fractures and edge chips. Edge chips which do not encroach on the free aperture of the prism shall be allowable within the following limitations: The sum of the chip widths shall not exceed 30 percent of the length of edge on which the chips occur. Chips shall be measured from the bevelling edge, not from sharp edge; i.e. after bevelling and not before. Chips less than 1/2mm shall not be counted and not stoned; chips larger than 1/2mm shall be stoned. Encroachment of chips shall be measured on the faces of the prism from the bevelled edges. If the nominal length (measured to sharp corner before bevelling) of the shortest edge of the prism which is adjacent to any polished face is an inch or less, chips may encroach the faces 1mm; if said length exceeds 25.4mm chips may encroach 2mm. This shall be permissible provided that there are no edge chips which interfere with mounting or sealing and the chips do not encroach upon the free aperture. Fractures visible to the unaided eye on any surface or edge are not permitted.

3.7.10.3 Drawing requirements. The deviation of angle errors, pyramidal error or error due to pyramid, spherical power, astigmatism, resolution, and image tilt shall be as specified on the drawings.

3.7.10.4 Erecting prisms. Erecting prisms shall be inspected as specified in 4.2.5.2.

3.7.10.5 Reflecting surfaces - silvered or aluminized.

3.7.10.5.1 Edges. The edges of partially silvered surfaces of ocular prisms shall be sharp and shall be free of irregularities when inspected with the aid of a magnifier of at least the power of the eyepiece of the instrument to which the prism pertains.

3.7.10.5.2 Defects. Defects on reflecting surfaces appear the same as defects on other optical surfaces and shall be treated in the same manner as specified in 3.7.10.1.

3.7.10.5.3 Aperture surfaces. Aperture surfaces of prisms through which light is to be transmitted shall be free from particles of silver or aluminum remaining from processing of other surfaces.

3.7.11 Reticles.

3.7.11.1 Surface quality. The surface quality shall be as specified on the drawings. When not so specified the surface quality shall be as specified for focal planes in 3.5.5.3, except for zone sizes. The central zone shall be the central area, one half the free aperture in width, for reticles having reticle graduation extremities within this area, and those reticles having horizontal and vertical lines without graduations outside the area. Reticles having graduations outside the central area, one half the free aperture in width, the central zone shall be the central area, three-fourths the free

aperture in width. Imperfections beyond the free aperture shall be permitted providing their characteristics do not impair performance of the instrument.

3.7.11.2 Edge chips. Edge chip limitations shall be evaluated in accordance with 3.7.9.2.

3.7.11.3 Parallelism of flat surfaces. Parallelism of reticle flat surfaces shall be within the tolerances specified by the drawings. Where no tolerance is given on the drawing, the tolerance shall be 6 minutes of arc deviation of light path.

3.7.11.4 Markings. Reticle markings shall be viewed through an eyepiece of essentially the same power under which the reticle will be viewed in the finished instrument. Letters and numerals (whether in part number or adjacent to graduations) shall be inspected primarily for legibility. Defects in numbers or letters shall be acceptable provided each letter of figure is legible beyond doubt. Unless otherwise specified, any printing style is permitted for letters and numbers, however, the style selected must be uniform throughout each reticle and must meet with the approval of the procuring agency. Line breaks one half the width of the line shall be permitted. For reticles containing more than 15 lines, 1 break per 5 lines or fraction thereof shall be permitted. All lines shall appear to be of uniform width and depth and the intersections of lines shall appear to be sharp. Smooth or abrupt variations in line width along the entire line shall not be in excess of 20 percent of the line width and in no case shall reticle lines be bowed in excess of 1/2 the reticle line width. The fillet radius at the intersection of reticle lines shall not exceed the line width. Acid burns shall be cause for rejection, if visible when the reticle is viewed with the appropriate eyepiece.

3.7.11.5 Illuminated reticles. If the brightness of a defect is greater than the brightness of a reticle line when illuminated by the associated instrument light or light of equal intensity, the defect shall be cause for rejection.

3.7.12 Wedge and window. Wedge and window surface quality shall be in accordance with 3.7.9.1.

3.8 Optical systems.

3.8.1 Unassembled. Optical systems of specified design procured unassembled shall be grouped into systems in accordance with the optical diagram pertaining to the system, and shall be inspected as specified in 4.2.9.

3.8.2 Assembled. Optical systems of specified design procured assembled in their respective instruments shall be assembled in accordance with the drawing and specification for the instrument, and shall be inspected as specified in 4.2.10.

3.8.2.1 Defect criteria. Defects not otherwise covered in this specification, which

will not impair the performance of the finished instrument, shall be permissible. Whether a particular defect shall be permitted will depend on the location of the element in the finished optical system. Defects in elements not near a focal plane are not as important as in elements which lie in or near a focal plane. In all instances primary emphasis shall be placed on the performance of the lens or prism rather than its appearance unless the latter definitely indicates poor workmanship. The order of importance is as follows:

- a. Most critical surfaces,
Etched surface of reticle
Surface of collective lenses in a focal plane
- b. Less critical surfaces,
Surface of ocular field lens nearest the reticle,
Collective lens, center lens or prism surfaces near a focal plane
- c. Least critical surfaces,
All other surfaces of windows, objectives, prisms,
erector, and eyelenses

3.8.2.2 Alignment. The optical elements of all optical systems procured assembled in their instruments shall be aligned so that the exit pupil viewed on the optical axis shall have a minor diameter not less than 90 percent of its major diameter. The exit pupil shall be concentric with the exit free aperture within 10 percent of the exit free aperture when viewed from a point on the optical axis at a distance of approximately two feet from the eyelens.

3.8.2.3 Sealed joints. When specified, moisture preventive sealing compound (see 3.2.4) shall be evenly applied to the optical component to form an unbroken bead. When injection sealing is utilized, 24 hours shall elapse before collimation of the instrument.

3.8.2.4 Padding. The use of pads, shims, wedges, or opening under or around optical elements is prohibited and shall be cause for rejection of the instrument unless specified by the drawings

3.8.2.5 Performance characteristics.

3.8.2.5.1 Vibration. After being subjected to the vibration test specified in 4.2.10.7 the optical instrument shall show no dirt (dust or lint) in excess of that allowed by the item specification. In the absence of detail requirements, dirt in any confined space shall not be in size or amounts larger than the allowable dig specification for the adjacent surface requiring the best dig quality. The instrument shall show no evidence of loose or damaged parts subsequent to this test.

3.8.2.5.2 Shock. All completed subassemblies in which an optical element is physically supported from another part or parts by a glass to metal bond shall be subjected to the shock test.

3.8.2.5.3 Cleanliness. The optical surface of completed instruments shall be clean and free of condensates and volatile substances when examined by method specified in 4.2.10.9. Dust retention grease shall not be used except with specific authorization of the responsible technical activity.

3.8.2.5.4 Parallax. Parallax shall be removed where specified in 4.2.10.4.

3.8.2.5.5 Fixed eyepiece focus. Unless otherwise specified the reticle at the center of the field shall be in sharp focus when the eyepiece is set between minus 0.75 and minus 1.0 diopter. A calibrated dioptometer with a magnification of at least 3 power or an equivalent auxiliary telescope shall be used to make this setting.

4. VERIFICATION

4.1 General provisions. Unless otherwise specified in the contract or purchase order, the supplier is responsible for the performance of all inspection requirements as specified herein. Except as otherwise specified, the supplier may utilize his own facilities or any commercial laboratory acceptable to the Government. The Government reserves the right to perform any of the inspections set forth in the specification where such inspections are deemed necessary to assure supplies and services conform to prescribed requirements.

4.1.1 Examination and tests.

a. Classification of characteristics. Conformance examinations and tests are specified in the item specification's Classification of Characteristics paragraphs. The contractor's quality program or detailed inspection system will provide assurance of compliance of all characteristics with the applicable drawing and specification requirements utilizing, as a minimum, the conformance criteria specified. Unless otherwise cited in the contract or item specification, attributes sampling inspection shall be conducted in accordance with TABLE II below, using the inspection levels stated in the Classification of Characteristics paragraphs of the item specification.

For the classification of characteristics, the following definitions apply:

Critical - A critical defect is a defect that judgment and experience indicate would result in hazardous or unsafe conditions for individuals using, maintaining, or depending upon the product, or a defect that judgment and experience indicate is likely to prevent performance of the tactical function of a major end item such as a tank, land vehicle, missile, aircraft, artillery, or other major weapon system.

Major - A major defect is a defect, other than critical, that is likely to result in failure, or to reduce materially the usability of the unit of product for its intended purpose.

Minor - A minor defect is a defect that is not likely to reduce materially the usability of the unit of product for its intended purpose, or is a departure from established standards having little bearing on the effective use or operation of the unit.

TABLE II. Attributes sample inspection.

Inspection Levels Lot Size	I	II	III	IV	V	VI
2 to 8	*	*	*	*	5	3
9 to 15	*	*	*	13	5	3
16 to 25	*	*	*	13	5	3
26 to 50	*	*	32	13	5	3
51 to 90	*	*	32	13	13	5
91 to 150	*	125	32	13	13	5
151 to 280	*	125	32	32	20	8
281 to 500	*	125	32	32	20	8
501 to 1200	*	125	80	50	20	13
1201 to 3200	1250	125	80	50	32	13
3201 to 10000	1250	125	125	50	32	13
10001 to 35000	1250	315	125	80	50	13
35001 to 150000	1250	315	125	80	50	13
150001 to 500000	1250	500	200	125	50	13
500001 and over	1250	500	200	125	50	13

Numbers under inspection levels indicate sample size; asterisks (*) indicate one hundred percent inspection.

If sample size exceeds lot size, perform one hundred percent inspection. Accept on zero and reject on one or more for all inspection levels.

b. Alternative conformance provisions. Unless otherwise specified herein or provided for in the contract, alternative conformance procedures, methods or equipment, such as statistical process control, tool control, variables sampling or other types of sampling plans, etc., may be used by the contractor when they provide, as a minimum, the level of assurance required by the provisions herein. Prior to applying such alternative procedures, methods or equipment, the contractor shall describe them in a written proposal submitted to the Government for evaluation. When required, the contractor shall demonstrate that the effectiveness of each proposed alternative is equal to or better than the specified conformance provision (s)

herein. In case of dispute as to whether the contractor's proposed alternative (s) provides equivalent assurance, the provisions of this specification shall apply. All approved alternative provisions shall be specifically incorporated into the contractor's quality program or inspection system, as applicable.

c. Inspection levels. All references to inspection levels in this document and its appendixes are to utilize the above Table II attributes sample inspection.

4.2 Methods of inspection.

4.2.1 Inspection, optical components. Optical components shall be inspected by approved optical methods and equipment in accordance with applicable item specifications. In absence of approved test methods and equipment, the following procedures of the general specification shall apply. Appropriate sampling procedures may be used with prior approval of the responsible technical activity.

4.2.1.1 Mechanical dimensions. Each optical component shall be checked for compliance with the mechanical dimensions of the drawing and shall be inspected in accordance with the requirements and tests in this specification.

4.2.1.2 Radioactive material. Finished glass shall be tested by X-ray spectrometer techniques, or an approved alternate, for compliance with 3.2.1.1. Equipment and method used in performing X-ray fluorescence must have a minimum detectable level for thorium and other radioactive material of less than 100 parts per million (ppm) with an accuracy of ± 25 PPM. Should analysis show any sample to exceed the requirement of 3.2.1.1 all glass in the lot from which the sample was obtained shall be rejected.

4.2.2 Surface quality. Each element shall be inspected by the following methods for compliance with 3.5.2, 3.5.5, 3.6.1, 3.7.9.1 and 3.7.10.1.

4.2.2.1 Inspection method No. 1. The element to be inspected shall be viewed against a ground glass or opal surface illuminated from behind by a 40 watt incandescent or 15 watt cool white fluorescent lamp approximately 3 inches from the glass. Two or more opaque horizontal bars occupying approximately 1/2 the area of the glass shall be placed in front of and in contact with the glass.

4.2.2.2 Inspection method No. 2. The light through ground glass from a 40 watt incandescent or 15 watt cool white fluorescent lamp shall be passed through the element. Defects are observed by light scattered from the surface while viewing it at approximately 90 degrees to the path of the beam against a dark background.

4.2.3 Temperature test.

4.2.3.1 Test No. 1. Three out of the first 10 of each type of cemented or bonded component completed under each contract shall be tested at the high and low temperatures specified in 3.7.1. If there is reason to doubt quality, the right is reserved to test additional samples as the inspector deems necessary. Components subjected to these tests shall have passed all other required tests.

4.2.3.2 Test No. 2. The cemented or bonded components shall be subjected to an ambient temperature of minus 80 ± 2 degrees F for 5 hours. When inspected visually at this temperature, and again after remaining five hours at room temperature, the optical assembly shall show no evidence of "feathering" or reticulation and there shall be no separation of the components. In performing this test the optical assemblies shall not be subjected to any undue thermal shocks while being cooled to minus 80 degrees F, or while being warmed to room temperature.

4.2.3.3 Test No. 3. The cemented optical assembly shall then be subjected to the following test at the high temperature. One of the components shall be held rigidly in such a manner that the cemented interface shall be approximately in a vertical plane. A weight of such magnitude as to induce in the optical assembly a unit shear stress of 5 ounces per square inch of area of the cemented or bonded surface shall be suspended from the other component. In no case shall the weight be less than one ounce. The entire apparatus shall be allowed to soak at an ambient temperature of plus 160 ± 2 degrees F, for 2 hours. The lens shall pass the requirements specified by 4.2.6 when tested at room temperature and the movement or slippage of one component with respect to the other shall not exceed .002 inch. In performing this test the optical assemblies shall not be subjected to any undue thermal shocks while being raised to 160 degrees F or while being cooled to room temperature.

4.2.3.4 Failure investigation. Failure of one optical assembly shall be cause for stopping shipments pending an investigation of the cause. The contractor shall institute an immediate investigation in the presence of a representative of the contracting officer if the representative desires to be present to determine the cause of failure. If the investigation discloses a fault in cementing or bonding, acceptance of optical assemblies incorporating this fault shall be stopped pending correction. The contractor shall correct his cementing technique and shall correct all faulty optical assemblies previously produced. Acceptance and shipments will be resumed when ten consecutive optical assemblies of the type rejected have successfully passed the temperature tests.

4.2.4 Temperature - relative humidity.

4.2.4.1 Sample size. Three out of the first 10 of each type of cemented or bonded components at the beginning of each contract, or upon change in method of cementing or change in type cement, shall be tested at the temperature-humidity conditions specified herein. If there is reason to doubt quality, the right is reserved to

test additional samples as the inspector deems necessary.

4.2.4.2 Test procedure. The cemented or bonded component shall be gradually heated in a dry atmosphere to plus 140 ± 2 degrees F, and then immediately placed in an ambient atmosphere of plus 130 ± 2 degrees F. at 95 percent relative humidity for 2 hours. The optical assemblies shall be removed from the humid atmosphere, immediately wiped dry, and allowed to cool to room temperature. After 8 hours at room temperature the component shall be subjected to the tests specified in 4.2.3.2 and 4.2.3.3. The test as specified in this paragraph shall be repeated in the same identical procedure whenever passable optical assemblies having edge separation or cement blisters at the start of the test increase, or additional cement defects develop not in excess of that specified in 3.6. Components failing the initial test, or a change in any cement defects, or the development of additional cement defects after the retest shall be cause for rejection including all optical assemblies having passable cement defects from the corresponding lots offered for inspection. All components subjected to the humidity tests shall be recemented and recoated if required prior to acceptance.

4.2.4.3 Rejection criteria. Failure of one component to pass the tests specified in 4.2.4 shall be cause for the components to be treated in the same manner as specified in 4.2.3.4.

4.2.5 Resolution test. Resolution test shall be standard and shall be performed using one of the resolving power charts, see Figure 1. Resolving power is a measure of the optical performance. The resolving power is the angular subtense (in seconds of arc) of a series of parallel bars that can just be resolved. Resolving power is measured by viewing charts containing parallel bars of appropriate equal spacings. An auxiliary telescope is used to obtain sufficient magnification. A resolving power chart shall consist of four sets of lines, all sets either entirely three or entirely four lines at 45 degree steps (horizontal, vertical, and two at 45 degrees). The three line sets shall contain lines that are five times as long as they are wide. The four line sets shall contain lines that are seven times as long as they are wide. The widths of lines and spaces shall be equal. The lines may be either black on a white background, or white on a black background. There shall be an identifying numeral in the center of the four sets of lines. The contrast shall be 100:1 minimum. The chart of appropriate dimensions may be located in a collimator, or it may be viewed directly. In the latter case, the chart shall be at least $2 M^2$ feet from the telescope objective, where M is the power of the telescope being tested. The angular subtense of a chart is measured in seconds and equals arc tangent $2W/X$, where W is the width of a chart line and X is either collimator focal length or distance from chart to telescope under test. The telescope under test is aligned so the chart is in the center of the field. The auxiliary telescope is added and oriented to again center the chart. With the diopter scale of the auxiliary telescope at zero, the telescope under test shall be focused on the numeral in the resolving power target. In reading resolution, the auxiliary telescope may be focused plus or minus $1/8$ diopter for each of the four meridians. All four

meridians shall have the correct line count. The limit of resolution is reached when individual lines within the pattern are no longer clearly separated.

4.2.5.1 Objective and erector. When an objective or erector is being inspected by means of the above chart, it shall be placed at the proper distance and the image formed by the objective or erector shall be viewed with a microscope at a given power as required by the item specification or the contracting officer. It shall be possible to discern a line structure in the blocks equivalent to the resolution specified. The chart shall be so illuminated as to give a brightness of the image of 10 to 20 millilamberts.

4.2.5.2 Lens. When the effect of the lens on the definition of the complete instrument is being checked, the other optical component of the instrument having approved quality shall be arranged exactly as in the actual instrument. The lens to be tested shall then be inserted in position, and the chart shall be viewed through the complete setup by means of an auxiliary telescope giving a combined power of 40 to 60 magnifications per inch of aperture. It shall be possible to discern a line structure in the block representing the line structure required for the specified resolution. The chart shall be so illuminated as to give a brightness of the image of 10 to 20 millilamberts. Any optical elements needed for this test that are not being manufactured by the contractor will be furnished by the contracting officer.

4.2.5.3 Image. Plane components used external to a optical system. The definition shall be tested by observing through the appropriate free aperture of the component, the image of a target of the form shown in Figure 1. The image shall be observed with a telescope of at least 5-power greater than the power of the optical system between the component and the eye.

4.2.5.4 Optical components or partial systems. Optical components or partial systems procured as such and not as complete systems shall be tested in accordance with the detail specification or contractual document.

4.2.6 Concentricity of lenses. Cemented and single lenses shall be checked for conformance with the concentricity requirements of 3.7.9.3. The instrument specified in 4.2.8 with modifications, may be used for this test except that the reticle in the collimator shall be capable of being focused to permit placing it in the focal plane of the lens combination consisting of the collimator objective and the lens undergoing test for concentricity, and the stage shall be constructed to permit the lens to rotate about the geometric axis.

4.2.7 Deviation of prisms. The angle of deviation of prisms shall be tested by checking the deviation of light rays passing through the prisms, by standard or approved spectrometer practices.

4.2.8 Parallelism. Windows, wedges, reticles or similar flat surfaces elements

shall be tested for parallelism of flat surfaces by checking the deviation of light rays passing through the element.

4.2.9 Inspection of optical systems procured unassembled.

4.2.9.1 Optical elements. The optical elements of these systems shall be subjected to the inspection specified in 4.2.1 thru 4.2.8.

4.2.9.2 Systems, grouped. The elements shall be grouped into systems for inspection and shipments. They shall be spaced, in accordance with the optical diagram pertaining to the system, and assembled in a master instrument or tester and tested for definition and quality of image. Elements causing unsatisfactory performance shall be replaced before acceptance of the system (see Figure 1 for testing targets, and 4.2.10.2 and 4.2.10.3 for outline of inspection).

4.2.10 Inspection of assembled optical systems.

4.2.10.1 Optical elements. The optical elements of these systems shall be subject to the inspection specified in 4.2.

4.2.10.2 Target. Targets used in testing optical systems may be either actual size targets or miniature targets contained in collimators. The actual size targets can be made by printing black lines on a white background. The target in a collimator may be an etched or photographic reticle duplicating in miniature form, a full size target. The targets will vary, as required, by the detailed specification, from plain crosslines to targets containing a plumb line, level line, tolerance limit lines, and graduated scales (see Figure 1 for resolution testing target).

4.2.10.2.1 Collimator reticle. The reticle cell of the collimator is adjustable so that the reticle may be moved toward or away from the objective to represent different outside distances at which an outside target would be placed. For example, suppose that the specification for a telescope requires that the instrument be free from parallax when viewing a target at a distance of 200 yards and a collimator target is to be used for testing. It is necessary to adjust the collimator reticle to represent this distance. This may be accomplished by removing parallax in a sample instrument when observing an outside target at 200 yards and then using this sample telescope to adjust the collimator reticle until there is no parallax observed when sighting through the sample telescope at the collimator reticle.

4.2.10.2.2 Image quality. When a collimator target is used to test the image quality of a telescope, due allowance shall be made for any aberrations of the collimator objective which will appear to be defects of the telescope being tested. Caution shall be exercised to eliminate the effect of these aberrations.

4.2.10.3 Instrument, inspection. Where necessary, the field may be observed by the use of a dioptrimeter or an equivalent auxiliary telescope to compensate for the individual inspector's eye accommodation.

4.2.10.4 Parallax. Parallax shall be removed at the center of the field unless otherwise specified in the detail specification.

4.2.10.5 Reticle scale spacings. Accuracy of angular subtense of reticle scale spacings of each reticle shall be tested by checking them against a target, which is an enlarged facsimile of the reticle; or a collimator reticle target. The enlarged target shall have black lines or marks against a white background and be placed at the proper distance with the face of the target perpendicular to the line of sight of the telescopes being tested.

4.2.10.6 Surface quality, reticle. Each reticle shall be checked for compliance with 3.7.11.1 by viewing with a magnifier whose magnification is equal to or greater than the pertinent viewing lens of the telescope of which it is a component. The light and method shall be the same as specified in 4.2.2.

4.2.10.7 Vibration test. Each optical instrument shall be mounted singly or in groups on an approved vibration machine and fixture and vibrated at an amplitude of not less than 1/16 inch (1/8 inch total movement at the center of the mounting face of the fixture) at a frequency of 30 Hz for 2 to 2 1/2 minutes.

4.2.10.8 Shock test. Shock testing of bonded and cement-supported assemblies. In absence of specific requirements each assembly shall be subjected to shock acceleration in a direction parallel to the plane of the joint in test for poor adherence or incomplete curing in the bonded or cemented joint. The time variation of the acceleration shall be roughly that of a half cycle of a sine function in which the time for increase of the acceleration from zero to maximum is 0.7 to 2.0 milliseconds. The amplitude of high frequency components in the time vs. acceleration curve shall not exceed 30 percent of the fundamental amplitude. Unless otherwise specified by the item specification, each assembly shall be subjected to six shocks of 150 G peak acceleration.

4.2.10.9 Cleanliness. Each optical system shall be examined through the objective and eyepiece ends with the unaided eye. Inspection for moisture shall be made by the technique of shadowing. Inspection for dust particles shall be made by viewing a uniformly illuminated field having a brightness of approximately 300 apparent foot-lamberts.

5. PACKAGING

5.1 Packaging. For acquisition purposes, the packaging requirements shall be as

specified in the contract or order. When actual packaging of materiel is to be performed by DoD personnel, these personnel need to contact the responsible packaging activity to ascertain requisite packaging requirements. Packaging requirements are maintained by the Inventory Control Point's packaging activity within the Military Department of Defense Agency, or within the Military Department's System Command. Packaging data retrieval is available from the managing Military Department's or Defense Agency's automated packaging files, CD-ROM products, or by contacting the responsible packaging activity.

6. NOTES

(This section contains information of a general or explanatory nature that may be helpful, but is not mandatory.)

6.1 Intended use. The finished optical components are to be used for fire control instruments such as sights, telescopes, periscopes and range finders either as individual elements, partial or complete systems, and assembled or unassembled, as required by contract.

6.2 Acquisition requirements. Acquisition documents should specify the following:

- a. Title, number and date of this specification.
- b. Selection of an applicable level of preservation, packaging and packing.
- c. Certified test reports are to be made available to the procuring activity upon request (see Appendix A and Appendix D).

6.3 Definitions.

6.3.1 Scratch. Any marking or tearing of the surface. Scratch types are identified as the following:

- a. Block reek - chain-like or interrupted scratches that are aligned.
- b. Runner-cut or cutter marks - curved scratch caused in grinding.
- c. Sleek - hairline scratch.
- d. Crush or rub - series of small surface scratches generally caused by mishandling.

6.3.2 Dig. A small rough spot on the polished surface similar to pits in

appearance, generally residuals of subsurface damage caused by grinding that didn't polish out or bubbles that open up.

6.3.3 Feathering. The physical change in cement causing the cement to lose its adhesion and develop into a feather like pattern.

6.4 Submission of alternative conformance provisions. All contractor proposed alternative conformance provisions will be submitted to the Government for evaluation/approval as directed by the contracting activity.

6.5 Drawings. Drawings listed in Section 2 of this specification under the heading U.S. Army Armament, Research, Development and Engineering Center (ARDEC) may also include drawings prepared by, and identified as U.S. Army Armament, Research and Development Command (ARRADCOM), Frankford Arsenal, Rock Island Arsenal or Picatinny Arsenal drawings. Technical data originally prepared by these activities is now under cognizance of ARDEC.

6.6 Subject term (key word) listing.

Digs
Reticles
Scratches
Surface Quality

6.7 Changes from previous issue. Marginal notations are not used in this revision to identify changes with respect to the previous issue due to the extent of the changes.

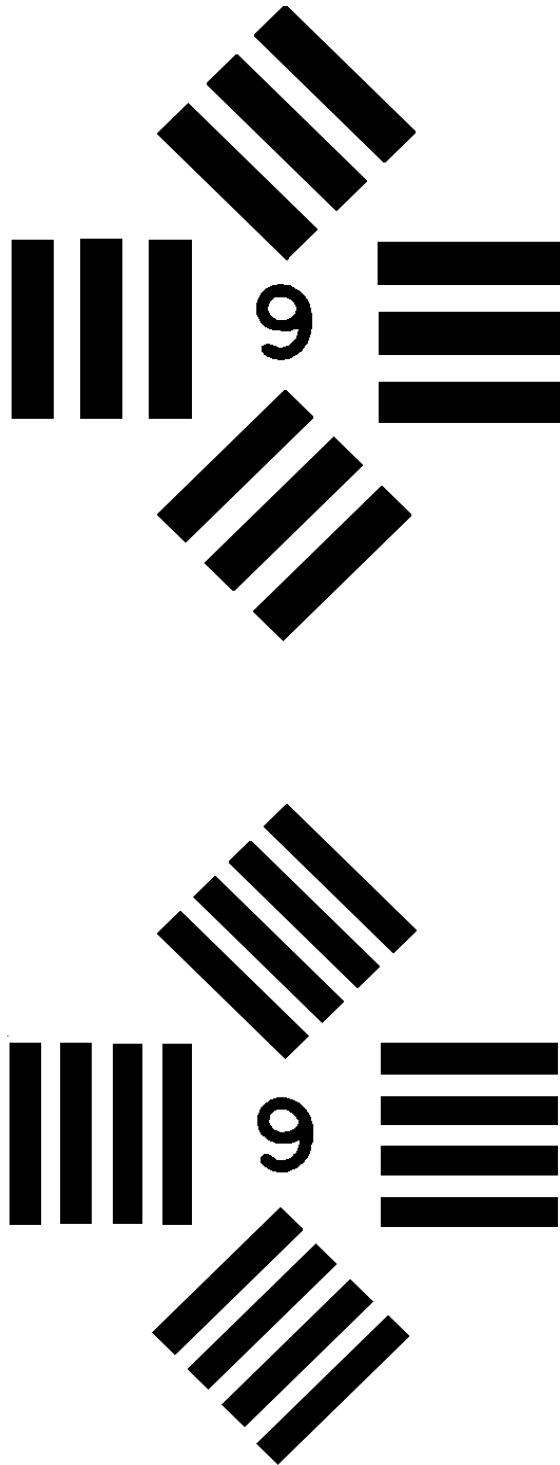

FIGURE 1. Resolving power chart (for illustration purposes only)

APPENDIX A

ADHESIVE, OPTICAL, THERMOSETTING

A.1 SCOPE

A.1.1 Scope. This appendix covers a thermosetting liquid resin adhesive for bonding optical elements for use in military optical instruments. This Appendix is a mandatory part of the specification. The information contained herein is intended for compliance.

A.2 APPLICABLE DOCUMENTS

A.2.1 General. The documents listed in this section are needed to meet the requirements specified in sections A.3, A.4, and A.5 of this specification. This section does not include documents in other sections of this specification or recommended for additional information or as examples. While every effort has been made to ensure the completeness of this list, document users are cautioned that they must meet all requirements documents cited in sections A.3, A.4, and A.5 of this specification, whether or not they are listed.

A.2.2 Non-Government publications. The following documents form a part of this document to the extent specified herein. Unless otherwise indicated, the issue in effect on the date of invitation for bids or request for proposal shall apply.

AMERICAN SOCIETY FOR TESTING AND MATERIALS (ASTM)

ASTM D1084 - Standard Test Methods for Viscosity of Adhesives

(Application for copies should be addressed to American Society for Testing and Materials, 100 Barr Harbor Drive, West Conshohocken, PA 19428-2959.)

A.2.3 Order of precedence. In the event of a conflict between the text of this document and the references cited herein, the text of this document takes precedence. Nothing in this document, however, supersedes applicable laws and regulations unless a specific exemption has been obtained. (See contract provisions for additional precedence criteria.)

A.3 REQUIREMENTS

A.3.1 Qualification. The adhesive furnished under this specification shall be a

APPENDIX A

product which has been tested and passed the qualification tests specified herein. Contractor certified test reports are to be made available upon request. (see A.6.2)

A.3.2 Adhesive. The optical adhesive shall be thermosetting. There shall be no restriction as to chemical type provided the adhesive meets all requirements specified herein.

A.3.3 Activator. If necessary, an activator may be used to cure the adhesive and shall be supplied in the proper quantity for activation with the adhesive.

A.3.4 Refractive index. The refractive index of the polymerized and polymerizable adhesive shall conform to the following:

A.3.4.1 Polymerized adhesive. The index of refraction of the polymerized adhesive shall be 1.530 to 1.560 at $25^{\circ} \pm 1^{\circ}\text{C}$ ($77 \pm 2^{\circ}\text{F}$).

A.3.4.2 Polymerizable adhesive. The index of refraction of the polymerizable adhesive shall be 1.510 to 1.545 at $25^{\circ} \pm 1^{\circ}\text{C}$ ($77 \pm 2^{\circ}\text{F}$).

A.3.5 Viscosity. The viscosity of the polymerizable adhesive shall be less than 800 centipoises at $25^{\circ} \pm 1^{\circ}\text{C}$ ($77 \pm 2^{\circ}\text{F}$).

A.3.6 Light transmission. The light transmission characteristics of the bonded optical elements shall be greater than or equal to 98.5% within the spectral range of 0.40 to 0.70 micrometers.

A.3.7 Lint and dust particles.

A.3.7.1 Adhesive. Lint and dust particles per 4 ounces polymerizable adhesive shall not exceed any of the following:

- 7 particles of 0.1mm maximum length
- 3 particles of 1.0mm maximum length
- 1 particles of 5.0mm maximum length

The total number of particles of any size per 4 ounces polymerizable adhesive shall not exceed 7.

A.3.7.2 Activator. When an activator is used to polymerize the adhesive, the lint and dust particles in that quantity of activator sufficient to polymerize 4 fluid ounces of the adhesive shall not exceed any of the following:

APPENDIX A

- 3 particles of 0.5mm maximum length
- 1 particles of 1.0mm maximum length

The total number of particles, of any size, shall not exceed 3 in the total quantity of activator necessary for 4 fluid ounces of adhesive.

A.3.8 Cure conditions. The adhesive shall cure with or without the addition of activator. When an activator is added, the adhesive shall cure either at room temperature $25^{\circ} \pm 5^{\circ}\text{C}$ ($77 \pm 10^{\circ}\text{F}$) in no more than 7 days; or at a temperature not to exceed 74°C (165°F), in no more than 3 hours. When an activator is not added, the adhesive may cure by exposure to ultraviolet radiation.

A.3.9 Environmental exposure. Ten bonded doublets (see 4.4) shall be subjected to three environmental exposure cycles. Each exposure cycle shall include water immersion, temperature exposure and humidity and shall be conducted in the following sequence:

- a. Immersion in distilled water at $38^{\circ} \pm 2^{\circ}\text{C}$ ($100^{\circ} \pm 4^{\circ}\text{F}$) for 22 hours.
- b. Exposure at a temperature of $-54^{\circ} \pm 2^{\circ}\text{C}$ ($-65^{\circ} \pm 4^{\circ}\text{F}$) for 22 hours.
- c. Exposure to 95 to 100% relative humidity at $71^{\circ} \pm 1^{\circ}\text{C}$ ($160^{\circ} \pm 2^{\circ}\text{F}$) for 22 hours.

Subsequent to the environmental cycles, the bonding layer shall be examined for evidence of edge separation, feathering, voids, or other forms of bonding layer disintegration. Each bonded doublet shall be evaluated for its bonding layer defect and assigned the corresponding weighted value, as defined in Table IA for its particular defect. The weighted value for the ten doublets shall be arithmetically averaged and this average weighted value shall be less than five.

A.3.10 Cold exposure. Five bonded doublets shall be exposed to a temperature of $-62^{\circ} \pm 2^{\circ}\text{C}$ ($-80^{\circ} \pm 4^{\circ}\text{F}$) for five hours. Subsequent to this cold temperature exposure, the bonding layer shall be examined for evidence of edge separation, feathering, voids or other forms of bonding layer disintegration. Each bonded doublet shall be evaluated for its bonding layer defect and assigned the corresponding weighted value as defined in Table IA, for its particular defect. The weighted value for the five doublets shall be arithmetically averaged, and this average weighted value shall be less than five.

APPENDIX A

A.3.11 Instruction sheet. The manufacturer shall provide an instruction sheet or pamphlet when requesting qualification and also with each unit package of adhesive outlining instructions for its use. The instruction sheet shall include as a minimum the following information:

- a. Manufacturer's designation for the adhesive and a description of the base polymer(s) and modifiers, if any, used in the adhesive.
- b. Mixing instructions, including type and amount of activators, if required, and temperature controls during mixing and minimum pot life of the mixed adhesive.
- c. Complete processes and treatments for preparing the glass surfaces prior to their bonding with the adhesive.
- d. Application instructions including the method of applying the adhesive to a glass surface and joining two glass surfaces together.
- e. Curing times and temperature, including any pre-cure or post-cure procedures.
- f. Suggested methods for decementing any poorly bonded assemblies.
- g. Necessary safety precautions to be observed throughout all operations.
- h. Any other pertinent information relative to the use and storage of the adhesive or activator, or both.

A.4. VERIFICATION

A.4.1 General provisions. Unless otherwise specified in the contract or purchase order, the supplier is responsible for the performance of all inspection requirements as specified herein. Except as otherwise specified, the supplier may utilize his own facilities or any facilities suitable for the performance of the inspection requirements specified herein, unless disapproved by the government. The government reserves the right to perform any of the inspections set forth in the specification where such inspections are deemed necessary to assure that supplies and services conform to prescribed requirements.

APPENDIX A

TABLE IA. Weighted Value

WEIGHTED VALUE	BONDED LAYER DEFECT DESCRIPTION	DEFECT TOLERANCE
0	Perfect	No defects in bonded surface
1	A separation from bevel into bonded surface at the periphery for 0 - 49% of the circumference	Up to 1.0mm penetration
2	A separation from bevel into bonded surface at the periphery for 50 - 100% of the circumference	Up to 1.0mm penetration
3	Same as #1	Up to 2.0mm penetration
4	Same as #2	Up to 2.0mm penetration
5	Same as #1	Up to 3.0mm penetration or bubble, void, or separation in the bonded surface greater than 0.41mm diameter but less than 1.0mm
6	A separation from bevel into bonded surface at the periphery for 50-100% of the circumference or a void, bubble, or separation in bonded surface.	Up to 3.0mm penetration or a bubble, void, or separation in the bonded surface greater than 0.41mm diameter but less than 1.0mm.
7	A separation from bevel into bonded surface at the periphery for 0 - 49% of the circumference of void, bubble or separation in bonded surface.	Up to 4.0mm penetration or a bubble, void, or separation greater than 1.1mm in diameter in bonded surface.
8	Same as #6	Same as #7
9	Any film condition worse than #8 with description noted.	Same as #7

A.4.2 Classification of tests. The inspection and testing of the adhesive shall be classified as follows:

- a. Qualification test (4.5)
- b. Conformance tests (4.6)

APPENDIX A

A.4.3 Preparation of glass discs. Glass discs as specified in Figure 1A shall be prepared in sufficient quantities to furnish the necessary number of bonded doublets required for the applicable tests of this specification. The optical characteristics of these discs shall be equal.

A.4.4 Preparation of bonded doublets. Glass discs, as specified in A.4.3, shall be thoroughly cleaned with ethyl alcohol and a camel hair brush prior to bonding. The adhesive shall be applied dropwise to the center of one of the cleaned discs and another disc placed on the adhesive-laden surface. Pressure shall be applied to spread the adhesive film evenly between the adherends employing rotary movement of the top element to obtain a bubble free film. Excessive adhesive shall be wiped from the periphery of the doublet and the film shall be cured in accordance with the manufacturer's instructions and in compliance with A.3.8.

A.4.5 Qualification tests.

A.4.5.1 Qualification tests. Qualification tests shall consist of all tests of this specification. (See A.6.3)

A.4.5.1.1 Sample size. The sample size of material for qualification testing shall be as directed by the qualifying activity.

A.4.5.1.2 Manufacturer's data. Two copies of the manufacturer's test report, containing complete test data certifying that the material submitted for qualification conforms to this specification shall be submitted with qualification test samples. Location and identity of the plant which produced the samples tested shall also be stated.

A.4.5.1.3 Instruction sheet. Duplicate copies of the manufacturer's instructions for use of the adhesive shall be furnished with the qualification samples. (See A.3.11)

A.4.5.1.4 Refractive index.

A.4.5.1.4.1 Polymerized adhesive. The index of refraction of the polymerized adhesive shall be measured using an Abbe refractometer at $25^{\circ} \pm 1^{\circ}\text{C}$ ($77^{\circ} \pm 2^{\circ}\text{F}$) using a white-light source to determine conformance with A.3.4.1.

A.4.5.1.4.2 Polymerizable adhesive. The index of refraction of polymerizable adhesive shall be measured with an Abbe refractometer at $25^{\circ} \pm 2^{\circ}\text{C}$ ($77^{\circ} \pm 2^{\circ}\text{F}$) using a white-light source to determine conformance with A.3.4.2.

APPENDIX A

A.4.5.1.5 Viscosity. The viscosity of the polymerizable adhesive shall be measured with a Brookfield Visometer, corrected to $25^{\circ} \pm 1^{\circ}\text{C}$ ($77^{\circ} \pm 2^{\circ}\text{F}$), in accordance with Method B, ASTM 1084.

A.4.5.1.6 Light transmission. The light transmission characteristics of the adhesive shall be determined using a dual-beam spectrophotometer. The test shall be performed by applying a layer of standard mineral oil (refractive index 1.47) between two glass discs to form a doublet. Prepare a total of two doublets in this manner. One of these doublets is then placed in both the reference and sample beam of the spectrophotometer. The spectrophotometer is then calibrated to obtain a 100% level throughout the visible spectrum from 0.40 to 0.70 micrometers. Doublets bonded with the adhesive under examination are then individually placed in the sample compartment (the standard mineral oil sample is replaced by the adhesive bonded doublet) and measured for compliance with A.3.6.

A.4.5.1.7 Dust and lint content. The cleanliness of the polymerizable adhesive and activator, if required, shall be inspected by placing the sample between two polarizing filters whose faces are placed parallel and whose axes of polarization are crossed at 90° . A diffuse white light source is placed in front of the first filter and viewed from behind the second filter to determine conformance with A.3.7.

A.4.5.1.8 Environmental exposure. Ten bonded doublets, prepared in accordance with A.4.4, shall be subjected to three environmental exposure cycles (of 3 tests each cycle) as specified in A.3.9. After each test within the cycle, the bonded doublets shall be allowed to cool or warm to room temperature before proceeding to the next test. Subsequent to exposure to the three environmental cycles, the bonded doublets shall be examined with the aid of one to three power (1X to 3X) magnification to determine conformance to A.3.9.

NOTE: Caution shall be exercised throughout this environmental exposure subjecting the doublets to thermal shock.

A.4.5.1.9 Cold exposure. Five bonded doublets, prepared in accordance with A.4.4, shall be subjected to the cold exposure specified in A.3.10. After exposure, the doublets shall be allowed to warm to ambient room temperature. The bonded doublets shall then be examined with the aid of one to three power (1X to 3X) magnification to determine conformance to A.3.10.

NOTE: Caution shall be exercised throughout this cold exposure to avoid subjecting the bonded doublets to thermal shock.

APPENDIX A

A.4.5.2 Qualification retest. Unless otherwise specified by the procuring activity, adhesives which have previously passed the qualification tests but have subsequently been modified in any manner, shall satisfactorily pass retesting of the material in order to retain qualification approval. Qualification tests may be repeated on material previously found satisfactory at any time at the option of the activity responsible for qualification approval. Failure will constitute cause for removal from Qualified Products List.

A.4.6 Conformance test. Quality conformance test shall consist of the sampling plans specified in A.4.6.1.

A.4.6.1 Sampling for inspection and acceptance. Two unit bottles of adhesive and two bottles of activator (sufficient to cure the adhesive) if required, shall be selected at random from each lot. The adhesive in each container shall be subjected to the following determinations. If either sample fails any test, the lot shall be rejected.

- a. Refractive index of polymerizable adhesive (A.4.5.1.4.2).
- b. Viscosity (A.4.5.1.5).

5. PACKAGING

5.1 Packaging. For acquisition purposes, the packaging requirements shall be as specified in the contract or order (see A6.2). When actual packaging of materiel is to be performed by DoD personnel, these personnel need to contact the responsible packaging activity to ascertain requisite packaging requirements. Packaging requirements are maintained by the Inventory Control Point's packaging activity within the Military Department of Defense Agency, or within the Military Department's System Command. Packaging data retrieval is available from the managing Military Department's or Defense Agency's automated packaging files, CD-ROM products, or by contacting the responsible packaging activity.

A.6. NOTES

(This section contains information of a general or explanatory nature that may be helpful, but is not mandatory.)

A.6.1 Intended use. The adhesive covered by this specification is intended for bonding optical elements in military optical systems.

APPENDIX A

A.6.2 Acquisition requirements. Acquisition documents should specify the following:

- a. Title, number and date of this specification
- b. Quantity desired
- c. Size of container: 1oz or 4oz
- d. Certified test report for this adhesive shall be available upon request by the procuring activity.
- e. Special Markings:
 1. Adhesive Optical Thermosetting
 2. Specification
 3. Manufacturer's name and address
 4. Volume contained
 5. Lot number
 6. Manufacturer's designation
 7. Date of manufacture
 8. Store in cool, dark place

APPENDIX A

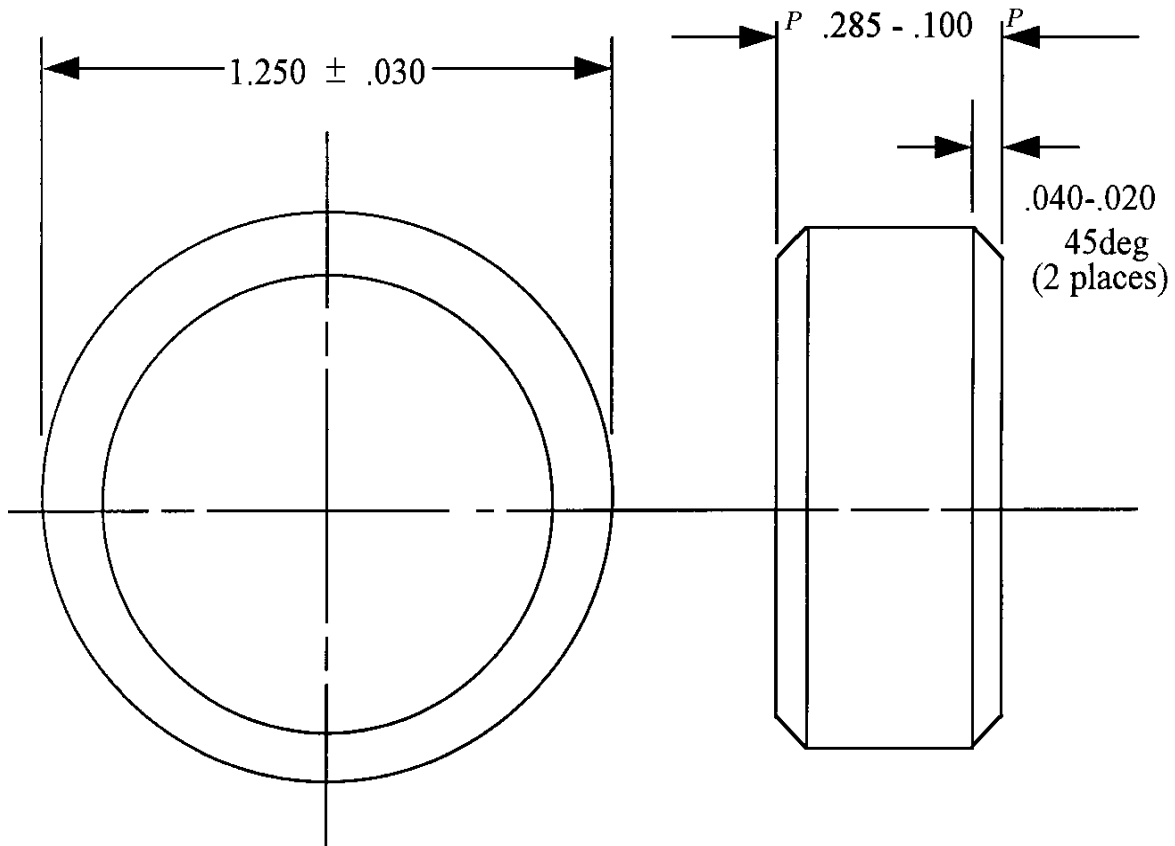

NOTE: Glass type BK7 or equivalent
Surfaces marked "P" polish, surface quality 80-50

FIGURE 1A. Glass disc (dimensions in inches)

APPENDIX B

MIRROR, FRONT SURFACED ALUMINIZED,
FOR OPTICAL ELEMENTS

B.1 SCOPE

B.1.1 Scope. This specification covers a mirror coating consisting of a deposited aluminum reflective film overlaid with a transparent dielectric protective film applied on the front surface of optical elements. This Appendix is a mandatory part of the specification. The information contained herein is intended for compliance.

B.2 APPLICABLE DOCUMENTS

B.2.1 General. The documents listed in this section are needed to meet the requirements specified in sections 3, 4, and 5 of this specification. This section does not include documents in other sections of this specification or recommended for additional information or as examples. While every effort has been made to ensure the completeness of this list, document users are cautioned that they must meet all requirements documents cited in sections 3, 4, and 5 of this specification, whether or not they are listed.

B.2.2 Non-Government publications. The following documents form a part of this document to the extent specified herein. Unless otherwise indicated, the issue in effect on the date of invitation for bids or request for proposal shall apply.

AMERICAN SOCIETY FOR TESTING AND MATERIALS (ASTM)

ASTM B117 - Standard Practice for Operating Salt Spray (Fog) Testing Apparatus

(Application for copies should be addressed to American Society for Testing and Materials, 100 Barr Harbor Drive, West Conshohocken, PA 19428-2959.)

B.2.3 Order of precedence. In the event of a conflict between the text of this document and the references cited herein, the text of this document takes precedence. Nothing in this document, however, supersedes applicable laws and regulations unless a specific exemption has been obtained. (See contract provisions for additional precedence criteria.)

B.3 REQUIREMENTS

APPENDIX B

B.3.2 Optical elements. The supplier is responsible for the quality of the optical elements used as backing for a front surface mirrored finish. Optical elements shall have been manufactured, tested and approved for use in accordance with the applicable element drawing and referenced specifications prior to the coating process.

B.3.3 Coating process. The coating process producing the front surface mirror finish shall cause no impairment to the optical element. Optical elements which have met the requirements of B.3.2 shall not be rejected because of fine hair lines, scratches, digs or stains which are made more visible by the coating process.

B.3.3.1 Aluminum film. The deposited film shall be of high quality aluminum. There shall be no visible discontinuities or blemishes that adversely affect the field of view as seen with the eye in the specified viewing position.

B.3.3.2 Protective film. The front surface aluminum film shall be protected by a film of high quality uniform magnesium fluoride or silicon monoxide or as otherwise specified on the applicable drawing. The film shall be free from holes, foreign matter and perceptible variations in density.

B.3.4 Reflectance. The finished coated surface, for visible use, shall have more than 80 percent luminous reflectance when measured at required angle of incidence, or a reflectance as otherwise specified on the applicable drawing.

B.3.5 Optical quality. The finished coated surface shall conform to the pertinent optical requirements set forth on the applicable drawing.

B.3.6 Coated area. The optical element shall be coated over its entire effective aperture or as otherwise specified by the applicable drawing.

B.3.7 Temperature influence. The coated surface shall show no signs of deterioration or removal of films after being subjected to ambient temperature of $-80^{\circ} \pm 2^{\circ}$ F and also $+160^{\circ} \pm 2^{\circ}$ F for a period of five hours at each temperature.

B.3.8 Hardness. The coated surface shall show no signs of deterioration such as streaks or hairline scratches as defined in MIL-PRF-13830 after being hand rubbed with a dry cloth.

B.3.9 Adherence. No part of the aluminum or protective films shall be removed when cellophane tape is pressed against the coated surface and slowly removed.

B.3.10 Humidity and salt spray. When specified in the contract the coated

APPENDIX B

surface shall show no evidence of corrosion or pitting when exposed to a relative humidity of 95 to 100 percent at $120^{\circ}\text{F} \pm 4^{\circ}\text{F}$ for a period of 24 hours and when exposed to a salt spray for the same time period. (See B.6.1)

B.4. VERIFICATION

TABLE IB, Classification of Defects
INSPECTION LEVEL III

Class	Requirement	Test Procedure
Critical: None defined		
Major:		
101. Aluminum film	B.3.3.1	B.4.4.1
102. Protective film	B.3.3.2	B.4.4.1
103. Reflectance	B.3.4	B.4.4.2
104. Optical quality	B.3.5	B.4.4.3
105. Coated area	B.3.6	B.4.4.1
106. Temperature influence	B.3.7	B.4.4.4
107. Hardness	B.3.8	B.4.4.5
108. Adherence	B.3.9	B.4.4.6
109. Humidity	B.3.10	B.4.4.7
110. Salt spray	B.3.10	B.4.4.8

Minor: None defined

B.4.4 Methods of inspection.

B.4.4.1 Coating process. Use a visual inspection and procedures set forth in MIL-PRF-13830 para. 4.2.2 to determine compliance with requirements B.3.3.1, B.3.3.2, and B.3.6.

B.4.4.2 Reflectance. The reflectance of the finished mirror at the required angle of incidence shall be measured either with a photometer for luminous reflectance or an instrument (spectrophotometer) capable of measuring nonvisual reflectance as otherwise specified on the applicable drawing to determine conformance with the requirements of B.3.4.

B.4.4.3 Optical quality. Use testing procedures as specified in para. 4.4.2 of MIL-

APPENDIX B

PRF-13830 or as otherwise specified on applicable drawing to determine compliance with requirement B.3.5.

B.4.4.4 Temperature influence. The element shall be exposed to ambient temperatures of $-80^{\circ} \pm 2^{\circ}\text{F}$ and $+160^{\circ} \pm 2^{\circ}\text{F}$ for a period of 5 hours at each specified temperature. A visual inspection shall be made after the element is returned to standard ambient temperature ($+60^{\circ}$ to 90°F) to determine compliance with the requirement B.3.7.

B.4.4.5 Hardness. This test shall be performed using a pad of clean, dry, cheesecloth, approximately 3/8 inch diameter and 1/2 inch thick. Bearing with a force of one pound \pm 1/4 lb. on the protected clean surface of the element, rub a minimum of 50 strokes across the surface in straight lines or circular motions. Subsequent to this procedure the protective coating must meet the requirements of B.3.8.

B.4.4.6 Adherence. Place the sticky surface of cellophane tape over a portion of the coated surface. Press the tape firmly against the coated surface. Pull the tape down over the edges of the element and then slowly remove the tape. A visual inspection shall be made of the tested area to assure that the films have not been removed from the substrate material to determine compliance with B.3.9. Edges not forming a part of the reflecting surface shall not be considered when inspection is being performed.

B.4.4.7 Humidity. The coated elements shall be exposed for a period of 24 hours in a thermostatically controlled humidity chamber having a relative humidity of between 95 and 100 percent at $120^{\circ} \pm 4^{\circ}\text{F}$. The elements shall be removed from the chamber and dried with lens tissue or soft cloth, then visually inspected to determine compliance with the requirements of B.3.10. (see B.6.1)

B.4.4.8 Salt spray. A visual inspection of the element shall be made of the coating after exposure to the salt spray test in accordance with ASTM B117.

B.5 PACKAGING

(This section is not applicable to this appendix.)

B.6 NOTES

(This section contains information of a general or explanatory nature that may be helpful, but is not mandatory.)

APPENDIX B

B.6.1 Humidity and salt spray. Humidity and salt spray requirements and tests are applicable only when specifically required by contract. The contract shall also prescribe the specific protective coating that will meet the environmental requirements of B.3.10.

APPENDIX C

COATING OF GLASS OPTICAL ELEMENTS
(ANTI-REFLECTION)

C.1. SCOPE

C.1.1 Scope. This appendix establishes the minimum optical and durability requirements for magnesium fluoride interference films used as anti-reflection coatings on optical materials. This Appendix is a mandatory part of the specification. The information contained herein is intended for compliance.

C.2. APPLICABLE DOCUMENTS

C.2.1 General. The documents listed in this section are needed to meet the requirements specified in sections 3, 4, and 5 of this specification. This section does not include documents in other sections of this specification or recommended for additional information or as examples. While every effort has been made to ensure the completeness of this list, document users are cautioned that they must meet all requirements documents cited in sections 3, 4, and 5 of this specification, whether or not they are listed.

C.2.2 Other Government documents, drawings, and publications. The following other Government documents, drawings, and publications form a part of this document to the extent specified herein. Unless otherwise specified, the issues are those cited in the solicitation.

DRAWINGS

U.S. Army Armament Research, Development and Engineering Center (ARDEC)

C7641866 Surface Quality Comparison Standards
D7680606 Coating, Eraser Abrasion Tester

(Copies of other Government documents, drawings, and publications required by contractors in connection with specific acquisition functions should be obtained from the contracting activity or as directed by the contracting activity.)

C.2.3 Non-Government publications. The following document(s) form a part of this document to the extent specified herein. Unless otherwise specified, the issues of the documents which are DoD adopted are those listed in the issue of the DODISS

APPENDIX C

cited in the solicitation. Unless otherwise specified, the issues of documents not listed in the DODISS are the issues of the documents cited in the solicitation (see C6.2).

AMERICAN SOCIETY FOR TESTING AND MATERIALS (ASTM)

ASTM B117 - Standard Practice for Operating Salt Spray (Fog) Testing Apparatus

(Applications for copies should be addressed to the American Society for Testing and Materials, 100 Barr Harbor Drive, West Conshohocken, PA 19428-2959.)

C.2.4 Order of precedence. In the event of a conflict between the text of this document and the references cited herein, the text of this document takes precedence. Nothing in this document, however, supersedes applicable laws and regulations unless a specific exemption has been obtained. (See contract provisions for additional precedence criteria.)

C.3. REQUIREMENTS

C.3.2 Materials. The material used for coating shall be a pure grade of Magnesium Fluoride adequate to meet all requirements of this specification.

C.3.3 Coated area. Optical components shall be coated over their entire clear aperture. In those instances where the clear aperture is not specified on the component drawing or procurement document the following allowable uncoated holding area shall apply:

Diameter or Maximum Diagonal Dimension of Optical Element	Maximum Width of Uncoated Area
Up to 2"	0.040"
Greater than 2"	0.040" plus additional width of 0.015" for each inch in diagonal greater than 2"
OR	OR
Up to 5 CM	1 MM
Greater than 5 CM	1 MM plus additional width increasing at the rate of 0.15 MM for each CM over 5 CM

APPENDIX C

In those instances where the clear aperture is specified, areas outside the clear aperture may be coated at the discretion of the contractor.

C.3.4 Coating quality. The coating shall be uniform in quality and condition and shall conform to the following:

C.3.4.1 Physical. The coating shall show no evidence of deterioration such as flaking, peeling, cracking or blistering.

C.3.4.2 Cosmetic. No stains, smears, streaks, or cloudiness shall be permitted on optical components lying in a focal plane beyond those permitted by the component drawing. Unless otherwise specified on the component drawing or procurement document, visual discolorations such as stains, smears, streaks, cloudiness, etc. on optical components which lie outside a focal plane in an optical system shall be acceptable when the stained area of the coated component conforms to the following as applicable:

- a. The transmission requirements of C.3.5.
- b. The reflection requirements of C.3.7.
- c. The adhesion requirement of C.3.8.5.
- d. The severe abrasion resistance requirement of C.3.8.4.1 for substrates having a Knoop hardness greater than 450 kg/mm^2 ; or the abrasion resistance requirement of C.3.8.4.2 for substrates having a Knoop hardness less than 450 kg/mm^2 .

NOTE: For purposes of this specification, should a question arise as to whether an optical component lies at or outside the focal plane, it will be assumed that it lies at the focal plane.

C.3.4.3 Spatter and holes. Coating spatter and holes shall be considered as a dig and shall not exceed the allowable dig size and quality stated on the component drawing or procurement document.

C.3.4.4 Surface defects (scratch and dig). Coating scratches and digs shall not exceed the values specified for the substrate on the component drawing or procurement document. Coating scratches and digs shall be considered separate from the substrate scratch and dig requirements.

APPENDIX C

C.3.5 Transmission. The increase in transmission of an element after coating at the wavelength that corresponds to a coating with a quarter wave optical thickness (QWOT) (See C.6.3) shall be equal to or greater than the value specified in Figure 1C, as applicable to the substrate's refractive index and surface(s) coated.

C.3.6 Film thickness. Unless otherwise specified on the component drawing or procurement document, the coating shall have a QWOT between 0.45 um and 0.60 um (See C.6.2)

C.3.7 Reflectance (at the minimum point). The magnitude of the specular reflectance for each coated surface at the minimum point on the spectral reflectance curve shall not exceed the values shown in Figure 2C, according to the refractive index of the substrate.

C.3.8 Durability.

C.3.8.1 Salt solubility. After immersion in a saline solution for a period of 24 hours, the coated surface shall meet the requirement of C.3.4.1 and the applicable abrasion resistance requirement of C.3.8.4.

C.3.8.2 Humidity. After exposure to an atmosphere of $120^{\circ} \pm 4^{\circ}\text{F}$ ($48.9^{\circ} \pm 2.2^{\circ}\text{C}$) and 95 to 100% relative humidity, the coated surface shall meet the requirements of C.3.4.1 and the applicable abrasion resistance requirement of C.3.8.4.

C.3.8.3 Salt spray fog. After exposure to a salt spray fog for a continuous period of 24 hours, the coated surface shall meet the requirements of C.3.4.1 and the applicable abrasion resistance requirements of C.3.8.4.

C.3.8.4 Abrasion resistance.

C.3.8.4.1 Severe abrasion. There shall be no visible damage, such as evidence of abrasion or coating removal, to the coated surface when abraded with a coating, eraser abrasion tester conforming to DWG 7680606. The requirement shall be performed on substrate materials that have Knoop hardness greater than 450 kg/mm².

C.3.8.4.2 Moderate abrasion. There shall be no visible damage, such as evidence of abrasion or coating removal, to the coated surface when abraded by a dry, clean, cheesecloth pad. The requirement shall be performed on substrate materials that have a Knoop hardness less than 450 kg/mm².

APPENDIX C

C.3.8.5 Adhesion. The coated optical surface shall show no evidence of coating removal when cellophane tape is pressed firmly against the coated surface and quickly removed at an angle normal to the coated surface.

C.4. VERIFICATION

C.4.1 General provisions. Unless otherwise specified in the contract or purchase order, the supplier is responsible for the performance of all inspection requirements as specified herein. Except as otherwise specified, the supplier may utilize his own facilities or any other facilities suitable for the performance of the inspection requirements specified herein, unless disapproved by the Government. The Government reserves the right to perform any of the inspections set forth in the specification where such inspections are deemed necessary to assure that supplies and services conform to prescribed requirements (See C.6.2).

C.4.1.1 Witness piece. Unless otherwise specified, witness pieces as defined in C.4.1.2 or coated components may be used to test the optical and durability requirements of the coated component (See C.4.2, C.4.3 and C.6.2). The witness pieces shall be positioned in the coating chamber such that they represent the optical and durability characteristics of the whole evaporated lot (See C.6.3). The Government reserves the right to test the actual coated component with the same test to which the witness pieces were subjected, except in the case where the known Knoop hardness of the coated component is less than 450 kg/mm², the moderate abrasion test of C.4.5.11 shall be utilized. Should a component fail, even through the representative witness pieces pass the test, the lot shall be rejected.

C.4.1.2 Characteristics of the witness piece. When the witness pieces are used to test the optical and durability requirements of the coated component they shall exhibit the following characteristics:

- a. The witness piece shall be such that it presents no difficulty in measuring and testing the optical and durability requirements of the coating.
- b. The witness piece shall have a surface finish similar to that of the component to be coated.
- c. The witness piece shall simulate the axial thickness of the component by either computational methods or using a witness piece that has the same thickness as the coated component for the measurement of transmission characteristics.

APPENDIX C

- d. The witness piece shall have a Knoop hardness greater than 450 kg/mm² and be a low staining material.

NOTE: When the refractive index and absorption coefficient of the witness piece differs from that of the component, the transmission difference between the coated and uncoated witness piece shall conform to Figure 1C; the reflectance of the quarter wave optical thickness (QWOT) coating on the witness piece shall be equal to or less than the value specified in Figure 2C.

C.4.2 First article (initial production) approval. The requirement for first article approval and the responsibility (government or contractor) for first article testing shall be as specified in the contract (See C.6.2). Unless otherwise specified, the sample for first article approval tests shall consist of five (5) coated components, plus fifteen (15) coated witness pieces (See C.4.1.2 and C.4.1.3). The five (5) coated components shall be tested as specified herein, for all the requirements of C.3.3, C.3.4.1, C.3.4.2, C.3.4.3 and C.3.4.4. The fifteen (15) coated witness pieces shall be divided into three (3) groups. Each group shall consist of five (5) each coated witness pieces. One group of five (5) coated witness pieces shall be tested, as specified herein, for all the requirements of C.3.5, C.3.6, C.3.7, C.3.8.1, and C.3.8.4.1. The second group of five (5) coated witness pieces shall be tested, as specified herein, for all the requirements of C.3.5, C.3.6, C.3.7, C.3.8.2 and C.3.8.4.1. The third group of five (5) coated witness pieces shall be tested, as specified herein, for all the requirements of C.3.5, C.3.6, C.3.7, C.3.8.3 and C.3.8.4.1. Except as noted herein, the government reserves the right to subject the coated components to all the tests specified. The sample shall be coated in the same manner using the same materials, equipment, processes and procedures as used in regular production. All materials shall be obtained from the same source of supply as used in regular production.

C.4.2.1 Government testing. When the government is responsible for conducting first article approval tests, the contractor, prior to submitting the sample to the Government, shall inspect the sample to insure that it conforms to all the requirements of the contract and submit a record of this inspection with the sample, including certificates of conformance for materials, as applicable.

C.4.2.2 Contractor testing. When the contractor is responsible for conducting first article approval tests, the sample shall be inspected by the contractor for all the requirements of the contract. The sample and a record of this inspection, including certificates of conformance for materials, shall be submitted to the Government for approval. The Government reserves the right to witness the contractor's inspection.

C.4.3 Inspection provisions.

APPENDIX C

C.4.3.1 Submission of product.

C.4.3.1.1 Inspection lot size. The inspection lot size shall consist of all components or subassemblies (unit of product) coated within one (8 through 12 hour) work shift.

C.4.3.1.2 Lot formation and presentation of lots. The unit of product shall be submitted for inspection on a moving inspection lot basis where the components or subassemblies are continuously offered for inspection in the order produced.

NOTE: Each evaporation lot (coated components and witness pieces) forming a part of a moving inspection lot shall be identified for subsequent evaluation, if required.

C.4.3.2 Examination and tests.

C.4.3.2.1 Components, subassemblies and witness pieces. The magnesium fluoride film coatings on components, subassemblies and witness pieces shall be inspected in accordance with this specification and the inspection provisions contained in Supplementary Quality Assurance Provisions (SQAP) or other procurement document listed in the Technical Data Package (TDP). Examination in accordance with the sampling plans specified in Table IC and IIC herein. The tabulated classification of defects in Table IC and IIC shall constitute the minimum inspection to be performed by the supplier after first article approval and prior to Government acceptance or rejection by item or lot.

APPENDIX C

TABLE IC - Classification of Defects

<u>CLASS</u>	<u>CHARACTERISTIC</u>	<u>REQUIREMENT</u>	<u>TEST PROCEDURE</u>
<u>CRITICAL:</u>	<u>NONE-DEFINED</u>		
<u>MAJOR</u>	<u>INSPECTION LEVEL III</u>		
101.	Coated area	C.3.3	C.4.5.2
102.	Coating quality, physical	C.3.4.1	C.4.5.3.1
103.	Coating quality, cosmetic	C.3.4.2	C.4.5.3.2
104.	Coating quality, spatter and holes	C.3.4.3	C.4.5.3.3
105.	Coating quality, scratch and dig	C.3.4.4	C.4.5.3.4
<u>MINOR:</u>	<u>NONE DEFINED</u>		

NOTE: The inspection for the characteristics in Table IC shall be conducted at a temperature between +60°F and +90°F (15.6°C and 32.2°C).

For the classification of characteristics, the following definitions apply:

Critical - A critical defect is a defect that judgment and experience indicate would result in hazardous or unsafe conditions for individuals using, maintaining, or depending upon the product, or a defect that judgment and experience indicate is likely to prevent performance of the tactical function of a major end item such as a tank, land vehicle, missile, aircraft, artillery, or other major weapon system.

Major - A major defect is a defect, other than critical, that is likely to result in failure, or to reduce materially the usability of the unit of product for its intended purpose.

Minor - A minor defect is a defect that is not likely to reduce materially the usability of the unit of product for its intended purpose, or is a departure from established standards having little bearing on the effective use or operation of the unit.

C.4.3.2.2 Acceptance and rejection. Lots or batches found unacceptable shall be resubmitted for reinspection only after all units are re-examined or retested and all defective units are removed or defects corrected. The responsible authority shall determine whether normal or tightened inspection shall be used, and whether

APPENDIX C

reinspection shall include all types or classes of defects or only the particular types or classes of defects which caused initial rejection.

C.4.3.2.3 Special sampling.

C.4.3.2.3.1 Optical and abrasive resistance. A minimum of three coated witness pieces, or coated components (when required), shall be selected from each evaporation lot as a special sample. The samples shall meet the requirements and tests in Table IIC.

TABLE IIC - Classification of Defects

<u>NO.</u>	<u>CHARACTERISTIC</u>	<u>REQUIREMENT</u>	<u>TEST PROCEDURE</u>
301.	Transmission	C.3.5	C.4.5.4
302.	Film thickness	C.3.6	C.4.5.5
303.	Reflectance at minimum point	C.3.7	C.4.5.6
304.	Severe abrasion	C.3.8.4.1	C.4.5.10

NOTE: The inspection for the characteristics in Table IIC shall be conducted at a temperature between +60°F and +90°F (15.6°C and 32.2°C).

C.4.3.2.3.2 Failure of special sample. Should any one item of a special sampling fail to meet the specified test requirements, acceptance of the represented evaporation lot shall be suspended by the Government until necessary corrections have been made by the contractor and the resubmitted item has been approved (See C.4.3.2.2).

C.4.5 Methods of Inspection.

C.4.5.1 Cleaning. Before and after subjecting a coated sample (component or witness piece) to any inspection or test, the coated sample shall be thoroughly and carefully cleaned to remove dirt, finger marks, smears, etc. The cleaning solution shall be acetone, ethyl alcohol, isopropyl alcohol, or mixtures thereof. Following the cleaning, the coated sample shall be carefully dried with lens tissue or a soft clean cloth. The temperature of the cleaning solution shall not exceed 80°F (26.7°C).

C.4.5.2 Coated area. The coated area of the component or subassembly shall be examined with standard measuring equipment (See C.6.3). The coated area shall conform to the requirements of C.3.3.

APPENDIX C

C.4.5.3 Coating quality.

C.4.5.3.1 Physical. The film coating on the component shall be visually examined by reflection, with the unaided eye, for evidence of flaking, peeling, cracking or blistering. The examination shall be performed using two 15 watt cool white fluorescent light tubes as the light source. The viewing distance from the coated surface to the eye shall not exceed 18 inches (45.7CM). The coated surface shall be viewed against a black matte background. The only illumination in the inspection area shall be from the light source used for examination.. The coating shall conform to the requirements of C.3.4.1.

C.4.5.3.2 Cosmetic. The film coating on the component shall be examined using the test method specified in C.4.5.3.1 for evidence of discoloration, stains, smears, streaks, cloudiness, etc. Coatings exhibiting any visual discoloration shall be subjected to the applicable tests (See note) specified in C.4.5.4, C.4.5.6, C.4.5.10, C.4.5.11 and C.4.5.12. The coating shall conform to the requirements of C.3.4.2.

NOTE: The test procedures selected for discolored coatings shall be compatible with component drawing requirements (C.4.5.4 or C.4.5.6) and the Knoop hardness of the component substrate (C.4.5.10 or C.4.5.11).

C.4.5.3.3 Spatter and holes. The film coating shall be examined for coating spatter and holes in the film coating using the applicable test method specified in C.4.5.3.4. The film coating shall conform to the requirements of C.3.4.3.

C.4.5.3.4 Surface defects (scratch and dig). The film coating of the component shall be examined utilizing the technique specified in C.4.5.3.1 except that magnification will be used where needed. The size of the scratch and dig (hole) in the coating shall be evaluated by comparison with the Surface Quality Standards for Optical Elements (scratch and dig) Drawing C7641866. The size of the scratch, and the diameter of the digs in the coating shall conform to the requirements of C.3.4.4. The lengths and density of all scratches, and the diameters and density of all digs shall conform to the requirements of MIL-PRF-13830, paragraph 3.5.

C.4.5.4 Transmission.

C.4.5.4.1 Witness pieces and components with plano surfaces. Coated witness pieces, and components with plano surfaces shall be tested for increase in transmission by use of a spectrophotometer. The transmission values of identical coated and uncoated witness pieces, or components, shall be obtained by spectrophotometric measurements. The increase in transmission after coating shall

APPENDIX C

conform to the requirements of C.3.5.

C.4.5.4.2 Lenses or components with curved surfaces. A coated lens or component with curved surface(s) shall be tested for increase in transmission by use of a photometer system (Pritchard Model No. 1980 or equivalent) that is capable of making a measured comparison between a coated and uncoated component. The increase in transmission after coating shall conform to the requirements of C.3.5.

NOTE: The spectrophotometric inspection methods specified in C.4.5.4.2 will only be used for acceptance inspection when it is necessary to evaluate a coated lens or component with curved surface(s) that has a visual discoloration since the values obtained are relative, not absolute.

C.4.5.5 Film thickness. Perform this test on a witness piece, coated on one side, utilizing a spectrophotometer. A specular reflectance curve shall be obtained and used to determine the QWOT. The QWOT is the wavelength associated with the minimum point on the reflectance curve. The QWOT shall conform to the requirements of C.3.6 (See C.6.3).

C.4.5.6 Reflectance at the minimum (witness pieces and plano surfaces). Perform this test concurrent with the test for optical film thickness. The percentage of reflectance at the minimum point on the spectral reflectance curve shall conform to the requirements of C.3.7.

NOTE: This test is not applicable to components with curved surfaces.

C.4.5.7 Salt solubility. The coated witness piece shall be immersed for a period of 24 hours in a solution of water and sodium chloride (salt). The mixture shall be 6 ounces (170 grams) of salt per gallon (3.8 liters) of water at room temperature (16° to 32°C). Subsequent to this immersion the coated witness piece shall be removed from the solution and gently washed, or dipped in clean running water not warmer than 100°F (38°C) to remove salt deposits. The witness piece shall then be cleaned (See C.4.5.1), dried, and then subjected to the examination specified in C.4.5.3.1. Subsequent to the visual examination for physical defects the witness piece shall be subjected to the test in C.4.5.10. The film coating on the witness piece shall meet the requirements of C.3.8.1 and C.3.8.4.1.

C.4.5.8 Humidity. The coated witness piece shall be placed into an environmentally controlled test chamber and exposed to a temperature of 120° ± 4°F (48° ± 3°C) 95% to 100% relative humidity for a minimum of 24 hours. Subsequent to this exposure the coated witness piece shall be removed from the test chamber,

APPENDIX C

cleaned (See C.4.5.1.), dried, and then subjected to the examination specified in C.4.5.3.1. Subsequent to the visual examination for physical defects, the witness piece shall be subjected to the test in C.4.5.10. The film coating on the witness piece shall meet the requirements of C.3.8.2 and C.3.8.4.1.

C.4.5.9 Salt spray (fog). The coated components, or witness piece shall be subjected to a salt spray fog test in accordance with ASTM B117, for a continuous period of 24 hours. Subsequent to the salt spray fog exposure the witness piece shall be washed and dried as specified. The witness piece shall then be cleaned (See C.4.5.1), dried, and then subjected to the examination specified in C.4.5.3.1. Subsequent to the visual examination for physical defects the witness piece shall be subjected to the test in C.4.5.10. The film coating on the witness piece shall meet the requirements of C.3.8.3 and C.3.8.4.1.

C.4.5.10 Severe abrasion. The coated components, or witness piece, shall be subjected to a severe abrasion by rubbing the coated surface with a standard eraser abrasion coating tester that conforms to the requirements of Drawing D7680606. The eraser shall be rubbed across the surface of the component, or witness piece, from one point to another over the same path for 20 complete cycles (40 strokes) with a force of 2.0 to 2.5 pounds continuously applied. The length of the stroke shall be approximately equal to 3 diameters of the eraser when the diameter or area of the component, or witness piece, permits. The eraser abrasion tester shall be held approximately normal to the surface under test during the rubbing operation. Subsequent to the rubbing operation the component or witness piece, shall be cleaned (See C.4.5.1), dried and then subjected to the examination specified in C.4.5.3.1 for evidence of physical damage to the coating. The film coating on the component, or witness, shall meet the requirements of C.3.8.4.1.

C.4.5.11 Moderate abrasion. The coated component shall be subjected to a moderate abrasion by rubbing the coated surface with a 1/4 inch (6.4MM) thick by 3/8 inch (9.5MM) wide pad of clean dry, laundered cheesecloth, affixed to the tester specified in C.4.5.10. The cheesecloth pad shall completely cover the eraser portion of the tester and be secured to the shaft with an elastic band. The cheesecloth pad shall be rubbed across the surface component from one point to another over the same path for 25 complete cycles (50 strokes) with a minimum force of 1.0 (0.45kg) pound continuously applied). The length of the stroke shall be approximately equal to two diameters of the cheesecloth pad when the diameter or area of the component permits. The abrasion tester shall be held approximately normal to the surface under test during the rubbing operation. Subsequent to the rubbing operation the component shall be cleaned (See C.4.5.1), dried and then subjected to the examination specified in C.4.5.3.1 for evidence of physical damage to the coating.

APPENDIX C

The film coating on the component shall meet the requirements of C.3.8.4.2.

NOTE: Where the Knoop hardness of the component is unknown it shall be subjected to the abrasion test of C.4.5.10.

C.4.5.12 Adhesion. The coated component shall be subjected to an adhesion test using 1/2" (12.7MM) wide cellophane tape. Press the adhesive surface of the cellophane tape firmly against the coated surface so as to cover the stained area, then quickly remove it at an angle which is normal to the coated surface. Immediately following the removal of the adhesive tape, the coated surface of the component shall be evaluated as specified in C.4.5.3.1 for evidence of coating removal. The film coating on the component shall meet the requirements of C.3.8.5.

C.5. PACKAGING

This section is not applicable to this appendix.

C.6. NOTES

(This section contains information of a general or explanatory nature that may be helpful, but is not mandatory.)

C.6.1 Intended use. The magnesium fluoride coating covered by this specification is applied to the surface of optical elements to increase light transmission and reduce reflections. The requirements defined by Figures 1C and 2C for transmission difference and maximum reflectance respectively, apply to coatings employed in the visible spectrum. Optical requirements for magnesium fluoride coatings used in ultraviolet or infrared spectral applications must be independently determined and specified.

C.6.1.1 Durability. The durability requirements established in this specification insure a level of quality consistent with military requirements. Additional durability requirements to confirm the suitability of a magnesium fluoride coating in a particular application should be considered when it is established that a coated optical element (coating and substrate) will exhibit the capability to satisfy the additional requirements.

C.6.1.2 Cosmetic defects. This specification permits certain cosmetic defects, such as stains, on coated optical elements. This requirement is established to permit the acceptance of coated elements where the defect is strictly aesthetic and the optical and durability properties of the coating are not impaired. The attention of

APPENDIX C

optical designers is directed to this requirement on an individual basis when cosmetic defects cannot be tolerated on the optical elements.

C.6.2 Acquisition requirements. Acquisition documents must specify the following:

- a. Title, number and date of this specification.
- b. Issue of DODISS to be cited in the solicitation, and, if required, the specific issue of individual documents referenced (see C.2.2).
- c. Requirements for submission of first article sample.
- d. Applicable stock number.
- e. Packaging requirements, if other than specified in Section 5.
- f. Serialization requirements, if applicable.
- g. Certificate of conformance for each lot or shipment of product.

C.6.3 Definitions.

C.6.3.1 QWOT. QWOT is the quarter-wave optical thickness defined as

$$\text{QWOT} = 4 \text{ nt}$$

where n is the reflective index of the coating
 t is the physical thickness of the coating

The QWOT has the dimension of length and is usually expressed as micrometers (μm) and nanometers (nm). Thus if a layer has a QWOT of 550 μm , this means that one-quarter wavelength of light at 550 μm has the same length as the optical thickness of the layer.

C.6.3.2 Standard measuring equipment (SME). Standard measuring equipment is defined as the common measuring devices which are usually stocked by commercial supply houses for ready supply (shaft items) and which are normally used by an inspector to perform dimensional inspection of items under procurement.. This category also includes commercial testing equipment such as meters, optical comparators, etc.

APPENDIX C

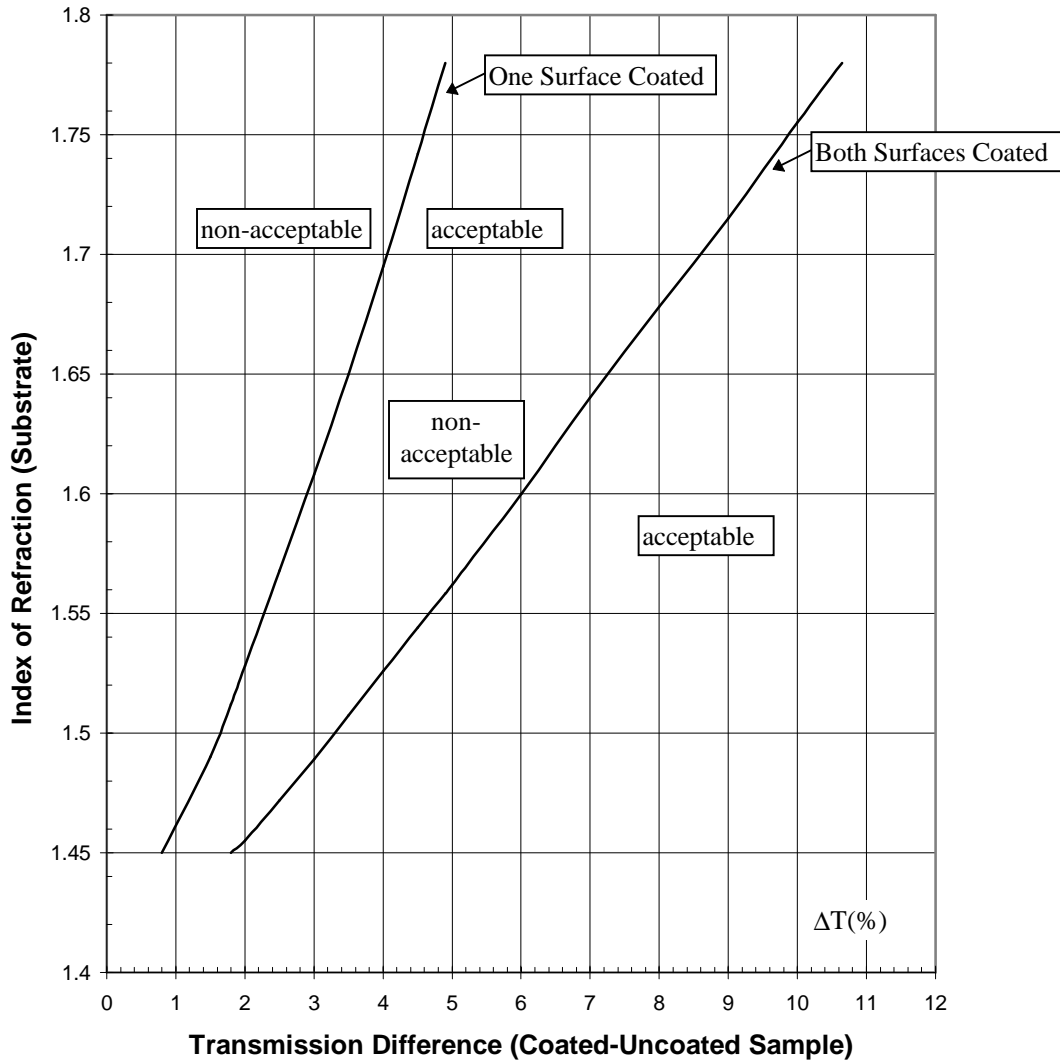

FIGURE 1C: Transmission

MIL-PRF-13830B

APPENDIX C

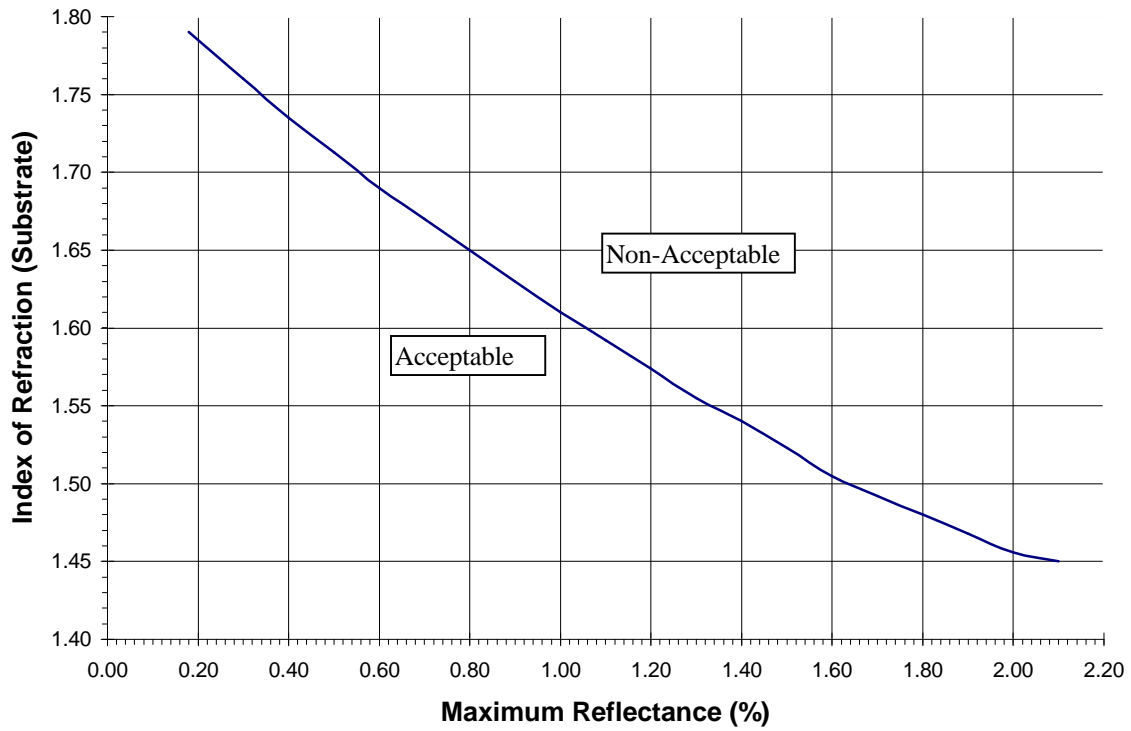

FIGURE 2C: Reflectance

APPENDIX D

ADHESIVE SYSTEM, EPOXY-ELASTOMERIC, FOR GLASS TO METAL

D.1. SCOPE

D.1.1 Scope. This amendment covers elastomer modified epoxy resin adhesive bonding systems for the structural joining of optical glass prisms to metal, the sealing of glass and metal components, and for other applications requiring bonding of a similar nature. This Appendix is a mandatory part of the specification. The information contained herein is intended for compliance.

D.1.2 Classification. Adhesives bonding systems shall be of the following types, as specified (see 6.2)

Type I - System composed of an epoxy primer component and an epoxy adhesive component.

Type II - System composed of an epoxy adhesive component.

D.2. APPLICABLE DOCUMENTS

D.2.1 General. The documents listed in this section are needed to meet the requirements specified in sections 3, 4, and 5 of this specification. This section does not include documents in other sections of this specification or recommended for additional information or as examples. While every effort has been made to ensure the completeness of this list, document users are cautioned that they must meet all requirements documents cited in sections 3, 4, and 5 of this specification, whether or not they are listed.

D.2.2 Non-Government publications. The following documents form a part of this document to the extent specified herein. Unless otherwise specified, the issues of the documents which are DoD adopted are those listed in the issue of the DoDISS cited in the solicitation. Unless otherwise specified, the issues of documents not listed in the DoDISS are the issues of the documents cited in the solicitation (see 6.2).

AMERICAN NATIONAL STANDARDS INSTITUTE (ANSI)

ANSI/SAE AMS 4035 - Aluminum Alloy Plate & Sheet (2024)

APPENDIX D

(Application for copies should be addressed to American National Standards Institute, 11 West 42nd Street, New York, NY 10036.)

AMERICAN SOCIETY FOR TESTING AND MATERIALS (ASTM)

ASTM D1640 - Standard Test Method for Drying, Curing, or Film Formation of Organic Coatings at Room Temperature

(Application for copies should be addressed to American Society for Testing and Materials, 100 Barr Harbor Drive, West Conshohocken, PA 19428-2959.)

D.2.3 Order of precedence. In the event of a conflict between the text of this document and the references cited herein, the text of this document takes precedence. Nothing in this document, however, supersedes applicable laws and regulations unless a specific exemption has been obtained. (See contract provisions for additional precedence criteria).

D.3 REQUIREMENTS

D.3.1 Qualification. The adhesive furnished under this specification shall be a product which has been tested, and passed the qualification tests specified herein. Contractor certified test reports are to be made available upon request (see 6.2).

D.3.2 Materials.

D.3.2.1 Components. The components of the Type I adhesive system shall consist of a primer and an epoxy-elastomer adhesive. The components of the Type II adhesive system shall consist of the epoxy-elastomer adhesive only.

D.3.2.2 Adhesive. The adhesive shall be a thermosetting resin and shall be based on epichlorohydrin-bisphenol A-Type epoxy resin, modified with acrylonitrile-butadiene rubber.

D.3.2.3 Primer. The Primer shall be a two component (Parts A and B) room temperature curing liquid epoxy and shall meet the physical properties of this specification.

D.3.3 Bond Strength (Type I and Type II). The bond strength for the Type I and Type II adhesive bonding systems shall be as specified in Table 1D.

APPENDIX D

TABLE ID Bond Strength

TEST NO.	PROPERTY	TEST CONDITIONS	NO. OF SPECIMENS	TEST TEMPERATURE	PARA. REF.	MIN AVG. STRENGTH REQT.	
						TYPE I	TYPE II
1.	Tensile Shear	23° ± 2° C, 50 ± 10% R.H.	6	23° ± 2° C	4.5.4.1	11 MPa	11 MPa
2.	Tensile Shear	60 minutes at 71° ± 2°C	6	71° ± 2°C	4.5.4.2	5.86 MPa	
3.	Tensile Shear	60 minutes at -51° ± 2°C	6	-51° ± 2°C	4.5.4.3	13.8 MPa	
4.	Tensile	10 days at at 71° ± 2°C & 95-100% R.H.	6	23° ± 2° C	4.5.4.4	11 MPa	

D.3.4 Low Temperature thermal stability (Type I and Type II). Bonded prisms shall not become detached or cracked when tested at $-62^{\circ} \pm 2^{\circ}\text{C}$ for 4 hours.

D.3.5 Mechanical shock stability (Type I only).

D.3.5.1 Mechanical shock stability- low temperature. Bonded prism assemblies shall not become detached during shock testing at $-43^{\circ} \pm 2^{\circ}\text{C}$. The bonded assemblies shall be shocked at 250, 300, 350, and 400 g's. The shock pulse shall have a wave form approximating a half-sine with a minimum time duration of 1.5 milliseconds.

D.3.5.2 Mechanical shock stability - high Humidity. Bonded prism assemblies shall not become detached during shock testing after exposure to 3 temperature humidity cycles. Each cycle shall consist of exposure to 95-100% relative humidity at $70^{\circ} \pm 3^{\circ}\text{C}$ for 24 hours. The bonded assemblies shall be shocked at 250, 300, 350, and 400 g's. The shock pulse shall have a wave form approximating a half-sine with a minimum time duration of 1.5 milliseconds.

D.3.6 Storage life. The Type I and Type II adhesive bonding systems shall meet the bond strength requirements of tests No. 1, 2, and 3 of Table ID, if applicable, after storage for 12 months at a temperature not to exceed $30^{\circ} \pm 2^{\circ}\text{C}$ in the absence of sunlight.

D.3.7 Product characteristics.

D.3.7.1 Adhesive component.

D.3.7.1.1 Application life. The application life of the adhesive when mixed and ready for use at $23^{\circ} \pm 3^{\circ}\text{C}$, shall be a minimum of 30 minutes.

APPENDIX D

D.3.7.1.2 Curing time and temperature. When subjected to a temperature not to exceed 74°C at the bond line, the adhesive shall cure in 4 hours maximum. At a temperature of 25° ± 2°C, the cure time shall not exceed 7 days.

D.3.7.1.3 Curing pressure. The adhesive shall be capable of curing and making satisfactory bonded joints as described within this specification when only contact pressure is applied during the period of cure.

D.3.7.2 Primer component.

D.3.7.2.1 Viscosity. The viscosity of the admixed primer (i.e. primer plus curing solution) one hour after mixing shall be 15 to 20 seconds using a No. 2 Zahn cup.

D.3.7.2.2 Drying time. The admixed primer shall set to touch in not more than 60 minutes and shall be dried hard in not more than 24 hours.

D.3.7.2.3 Mixing. Equal volumes of Component A and Component B shall show easy mixing to a smooth homogeneous product.

D.3.7.2.4 Pot life. The admixed primer shall have a minimum useable pot life of 8 hours at 25°C.

D.3.8 Instruction sheet. The manufacturer shall provide a dated, coded and titled instruction sheet with each shipment of adhesive outlining instruction for its use. The instruction sheet shall include the following information:

- a. Complete recommended pre-bonding treatments and cleaning processes.
- b. Maximum useable storage and pot life of the adhesive and primer. The pot life of the adhesive after the addition of the activator shall be based on definite quantities of the adhesive.
- c. Mixing instructions including recommended percentage of activator and any temperature control necessary when mixing the adhesive or primer.
- d. Application instructions, including application temperature and relative humidity, acceptable thickness range, and method of cleaning equipment.
- e. Typical cure conditions for the adhesive and primer.
- f. Necessary related data and precautions to be observed throughout all

APPENDIX D

operations, including:

1. Standard operating procedure (SOP) in the use of the material.
 2. Physical data on the characteristics of the components (boiling point and flash point).
 3. Fire and explosion hazard data including guidance on the proper protection to use if a fire occurs in the area.
 4. Reactivity data - guidance on classes of material which are not compatible with the components in the epoxy.
 5. Precautions to take in the event of a spill or leak.
- g. Any other pertinent information relative to the use and storage of the adhesive and or primer.

D.4 VERIFICATION

D.4.1 General provisions. Unless otherwise specified in the contract or purchase order, the supplier is responsible for the performance of all inspection requirements as specified herein. Except as otherwise specified, the supplier may utilize his own facilities or any commercial laboratory acceptable to the Government. The Government reserves the right to perform any of the inspections set forth in the specification where such inspections are deemed necessary to assure supplies and services conform to prescribed requirements.

D.4.2 Classification of inspection. The inspection and testing of the adhesive shall be classified as follows:

- a. Qualification tests (see D.4.5)
- b. Quality conformance tests (see D.4.6)

D.4.3 Test conditions.

D.4.3.1 Specimen conditions. All specimens shall be conditioned at $23^{\circ} \pm 2^{\circ}\text{C}$ and 50 percent relative humidity for at least 24 hours. Other conditioning shall be prescribed in Table 1. Preparation of the test specimens shall be in accordance with 4.4 and as described herein.

APPENDIX D

D.4.3.2 Normal conditions (room temperature). Strength properties shall be determined for room temperature adhesive at $23^{\circ} \pm 2^{\circ}\text{C}$, no sooner than 10 minutes after specimens have reached equilibrium at such temperature.

D.4.3.3 Elevated temperature Conditions. Conditioning of specimens for elevated temperature shear strength tests shall require a suitable oven to maintain the specimen at $71^{\circ} \pm 2^{\circ}\text{C}$ for a period of 60 minutes prior to testing.

D.4.3.4 Low temperature conditions Conditioning of specimens for low temperature shear strength tests shall require a suitable conditioning chamber to maintain the specimens at $-51^{\circ} \pm 2^{\circ}\text{C}$ for a period of 60 minutes prior to testing.

D.4.3.5 Humidity conditions. Conditioning of specimens for humidity shear strength tests shall require a suitable conditioning chamber to maintain the specimen at $71^{\circ} \pm 2^{\circ}\text{C}$ and 95 to 100% relative humidity for a period of 10 days prior to testing.

D.4.4 Preparation of test specimens.

D.4.4.1 Preparation of shear test specimens. Test specimens as shown in Figure 1D shall be prepared in sufficient quantities for all the necessary tests. Specimens for testing all the Table 1 properties shall be prepared from 0.32 cm (min) by 2.54 cm by 10 cm 2024-T3 aluminum conforming to ANSI/SAE AMS 4035; and glass microslides 2.54 cm by 2.54 cm by 0.30 cm (min). The cleaning, priming, and bonding procedures shall be in accordance the manufacturer's instruction sheet. The test specimens are to be assembled as shown in Figure 1D with the glass forming a bond of 6.45 sq. cm to one aluminum adherent and 3.23 sq. cm to the other aluminum adherent.

D 4.4.2 Preparation of thermal and mechanical shock stability test specimens. Test specimens shall be prepared in sufficient quantities for all the necessary tests. Specimens for testing the thermal and mechanical properties shall consist of right angle optical glass prisms 4 cm x 4 cm x 4 cm bonded to an aluminum plate 6 cm x 6 cm x 1.0 cm. The priming and bonding procedures shall be in accordance with the manufacturer's instruction sheet.

D.4.5. Qualification tests.

D.4.5.1 Qualification retest. Unless otherwise specified by the qualifying activity, adhesives which have previously passed the qualification tests but have subsequently

APPENDIX D

been modified in any manner shall satisfactorily pass re-testing of the material in order to retain qualification approval. Qualification tests may be repeated on material previously found satisfactory at any time at the option of the activity responsible for qualification approval.

D.4.5.2 Manufacturer's data. Qualification samples shall be accompanied by a test report showing results of all tests required by this specification except the tests for bond strength, low temperature thermal stability and mechanical shock stability.

D.4.5.3 Instruction sheet. Two copies of the manufacturer's instructions for use of the adhesive shall be furnished with the qualification samples (see D.3.8).

D.4.5.4 Tests. The qualification tests shall consist of all the tests of this specification.

D.4.5.4.1 Normal temperature tensile shear test.. (Test No. 1 of Table ID)
The test specimen shall be gripped tightly and uniformly across the ends of the jaws of the test machine with the jaws and specimen so aligned that the jaws are directly opposite each other, and in such a position that an imaginary straight line will pass through the center of the bonded area and through the points of suspension. All specimens shall be pulled at a jaw separation rate of 0.13 cm per minute. All failing loads shall be expressed in MPa of actual shear area, calculated to the nearest 0.65 sq cm. A total of six specimens shall be tested. The average strengths of these six specimens shall equal or exceed that specified for test number 1 in Table ID. An average shear strength, less than that specified in Table ID, shall cause rejection of the adhesive.

D.4.5.4.2 Elevated temperature tensile shear test. (Test No. 2 of Table ID)
The $71^{\circ} \pm 2^{\circ}\text{C}$ shear strength test shall be in accordance with D.4.5.4.1 with the added requirement that a suitable oven shall be provided to maintain the specimens at the specified test temperature (See D.4.3.3 and Table ID). Six specimens shall be tested for tensile shear test listed in Table ID. The average shear strength of each set of specimens tested shall equal or exceed that specified for Test No. 2 in Table ID. An average shear strength less than that specified in Table ID shall cause rejection of the adhesive.

D.4.5.4.3 Low temperature tensile shear test. (Test No. 3 of Table ID) The low temperature tensile shear test shall be in accordance with D.4.5.4.1 with the added requirement that a suitable chamber shall be provided in maintaining the temperature at $-51^{\circ} \pm 2^{\circ}\text{C}$ (see D.4.3.4). Six specimens shall be tested for tensile shear strength at $-51^{\circ} \pm 2^{\circ}\text{C}$. The average shear strength of test specimens shall

APPENDIX D

equal or exceed that specified for Test No. 3 of Table ID. An average shear strength less than that specified in Table ID shall cause rejection of the adhesive.

D.4.5.4.4 High humidity tensile shear test. (Test No. 4 of Table ID). The humidity tensile shear test shall be in accordance with D.4.5.4.1 after the specimens have been conditioned at $71^{\circ} \pm 2^{\circ}\text{C}$ and 95 to 100% relative humidity. A total of six specimens shall be tested. The average strengths shall equal or exceed that specified for Test No. 4 in Table ID. An average shear strength less than that specified in Table ID shall cause rejection of the adhesive.

D.4.5.4.5 Low temperature thermal stability. The adhesive shall be evaluated for its low temperature thermal stability by placing prism assemblies, prepared as specified in D.4.4.2, in a cold box at room temperature and allowing the temperature to drop to $-62.5^{\circ} \pm 2^{\circ}\text{C}$ at a rate not to exceed 20°C per hour. The temperature shall be maintained for four hours, after which the specimens shall be returned to room temperature and examined to meet the requirements of D.3.4. If one or more of the test specimens fails the test, the adhesive shall be rejected. A total of five specimens shall be tested.

D.4.5.4.6 Mechanical shock stability.

D.4.5.4.6.1 Mechanical shock stability-low temperature. The adhesive shall be evaluated for its low temperature mechanical shock stability by testing prism assemblies, prepared as specified in D.4.4.2 in the vertical plane, in accordance with the pulse shape, peak value and time duration as specified in D.3.5.1. The specimens shall be refrigerated by placing them in a cold box at room temperature and allowing the temperature to drop to $-51^{\circ} \pm 2^{\circ}\text{C}$ and maintaining that temperature for two hours. The specimens shall then be removed from the cold box and mounted on a fixture of the shock test machine and then shock tested. This must be done expeditiously so that the temperature of the assembly does not increase above -40°C . The mounted prism shall first be shock tested at 250 g's and the shock test increased at increments of 50 g's until the 400 g level has been reached. One shock test shall be made at each level. If one or more of the test specimens fails the test, the adhesive shall be rejected. A total of five specimens shall be tested.

D.4.5.4.6.2 Mechanical shock stability - High humidity. The adhesive shall be evaluated for its mechanical shock stability by testing prism assemblies in accordance with the pulse shape, peak value and time duration as specified in D.3.5.2. The specimens shall be placed in a humidity chamber at $71^{\circ} \pm 3^{\circ}\text{C}$ and 95 to 100% relative humidity for 24 hours. The specimens shall be removed from the humidity chamber and mounted on the fixture of a shock test machine and shock

APPENDIX D

tested. The mounted prism shall first be shock tested at 250 g's and the shock test increased at increments of 50 g's until 400 g's has been reached. Three shock tests shall be made at each interval. This combination of humidity and shock shall constitute one test cycle. A total of three cycles shall be performed. If one or more of the test specimens fails the test, the adhesive shall be rejected. A total of five specimens shall be tested.

D.4.5.4.7 Storage life tests. A .47 liter package of each component for Type I or Type II shall be stored under temperature and time conditions specified in D.3.6. At the end of the storage period, the components shall be used in the preparation of bonded lap joint specimens as required by test nos., 1, 2, and 3 of Table ID. Six specimens shall be tested at each of the applicable test conditions. The strength of the specimens shall be equal or exceed that specified for the applicable tests in Table ID.

D.4.5.4.8 Application life. Approximately 10 grams of the mixed adhesive shall be placed in a suitable container such as a plastic dish. A spatula with a 1 cm wide flat top shall be used in this test. Stir the adhesive frequently with the spatula and note the time at which the adhesive is considered to be definitely no longer spreadable on a glass or metal surface with spatula. The time to reach this consistency after mixing is the application life of the adhesive at $23^{\circ} \pm 3^{\circ}\text{C}$. The adhesive shall meet the requirements of D.3.7.1.1 for application life.

D.4.5.4.9 Primer viscosity. The viscosity of the primer shall be determined by using a number 2 Zahn cup. The cup shall be immersed in the admixed primer one hour after mixing. The temperature of the primer shall be maintained at $25^{\circ} \pm 2^{\circ}\text{C}$. After allowing bubbles to disappear when the cup is immersed in the primer, the cup shall be removed from the liquid and simultaneously the stop watch shall be started. At the first distinct break in the stream, the stop watch shall be stopped. The average elapsed time of three such readings shall be in conformance with D.3.7.2.1.

D.4.5.4.10 Primer drying time. The drying time shall be determined in accordance with ASTM D1640 during preparation of specimens specified in D.4.4 to determine compliance with D.3.7.2.2.

D.4.5.4.11 Primer mixing. Stir part A until completely uniform. Add an equal volume of part B, stir, and examine for conformity to the requirements of D.3.7.2.3.

D.4.5.4.12 Pot life. The admixed primer shall be brushable after 8 hours at $25^{\circ} \pm 2^{\circ}\text{C}$ to establish compliance with D.3.7.2.4. The primer may be kept covered during this test to minimize evaporation of solvent.

APPENDIX D

D.4.6 Quality conformance tests. Quality conformance tests shall consist of the sampling tests (D.4.6.1) and the inspection of filled containers (D.4.6.2).

D.4.6.1 Sampling for inspection and a acceptance.

D.4.6.1.1 Adhesive. One container of adhesive shall be selected at random from each lot. The adhesive shall be subjected to the tests in D.4.5.4.8. If the sample fails any tests, the lot shall be rejected.

D.4.6.1.2 Primer. One container of primer shall be selected at random from each lot. The primer shall be subjected to the following determinations. If the sample fails any test, the lot shall be rejected.

a. Drying time (D.4.5.4.10)

b. Mixing (D.4.5.4.11)

D.4.6.1.3 Lot. A lot shall consist of all the material (adhesive or primer offered for delivery at one time.

D.4.6.2 Sampling for inspection of filled containers. A random sample of filled containers shall be selected from each lot in accordance with inspection Level III, Table II. The sample containers shall be subjected to the inspection of filled containers as specified in D.4.7.

D.4.7 Inspection of filled containers. Each sample filled containers selected in accordance with D.4.6.2 shall be examined for defects of construction relative to the container and the closure, or evidence of leakage and for unsatisfactory markings. Each sample filled container shall be examined to determine the amount of contents. Any container in the sample having one or more defects or under required fill shall be rejected.

D.5 PACKAGING

D.5.1 Packaging. For acquisition purposes, the packaging requirements shall be as specified in the contract or order. (D.6.2) When actual packaging of materiel is to be performed by DoD personnel, these personnel need to contact the responsible packaging activity to ascertain requisite packaging requirements. Packaging requirements are maintained by the Inventory Control Point's packaging activity within the Military Department of Defense Agency, or within the Military

APPENDIX D

Department's System Command. Packaging data retrieval is available from the managing Military Department's or Defense Agency's automated packaging files, CD-ROM products, or by contacting the responsible packaging activity.

D.6. Notes

(This section contains information of a general or explanatory nature that may be helpful, but is not mandatory.)

D.6.1 Intended use. The adhesive systems covered by this specification are intended primarily for use in bonding glass to metal. The materials to be bonded include glass prisms and other optical elements to their metal supports in optical fire control instruments. For maximum reliability and environmental resistance especially to humid conditions, the Type I adhesive system is recommended. Both the Types I and II adhesive systems may be used for general purpose bonding of materials such as aluminum, stainless steel, brass, bronze, plastics, glass, etc., to themselves or in dissimilar combinations. Various bond line thickness may be used for bonded assemblies, however, for the structural bonding of glass prisms to metal mounts a bond line thickness of .036 to 0.41 cm is recommended.

Minor assemblies bonded with the adhesive systems of this specification should be thoroughly evaluated for the effect of the adhesive on the optical properties of the assemblies.

D.6.2 Acquisition requirements. Procurement documents should specify the following:

- a. Title, number, and date of this specification.
- b. Type required. (see D.1.2).
- c. Quantity desired.
- d. Certified test report for this adhesive shall be available upon request by the procuring activity.
- e. Package marking shall contain the following information:
 1. Specification and type..
 2. Manufacturer's designation.

APPENDIX D

3. Date of manufacture.
 4. Recommended expiration date.
 5. Storage requirements.
 6. Precautionary markings.
 7. Manufacturer's name and address.
 8. Manufacturer's batch identification.
 9. Certified test report for this adhesive shall be available upon request by the procuring activity.
- f. A copy of the manufacturer's instructions shall be enclosed with or attached to each container of adhesive as specified (see D.3.8).

D.6.3 Debonding procedure. Satisfactory debonding of glass to metal bonds, formed with epoxy based adhesives conforming to the requirements as contained herein, can be accomplished through the use of the solvent N-Methyl-2-Pyrrolidone. A quantity of solvent, sufficient to completely submerge the assembly to be debonded, should be brought to an elevated temperature in excess of 90°C but less than 150°C. (The higher the solvent temperature the faster will be the debonding effect). The volatility of the solvent at elevated temperatures will necessitate a hooded area plus the use of condensing retort for the confining and condensing of gaseous solvent. A debonding effect should be obtained in one hour or less for a 2cm² assembly and in three hours or less for an 9cm² assembly depending on actual solvent temperature. The time of submersion may have to be extended to completely remove the primer coating (if applicable).

APPENDIX D

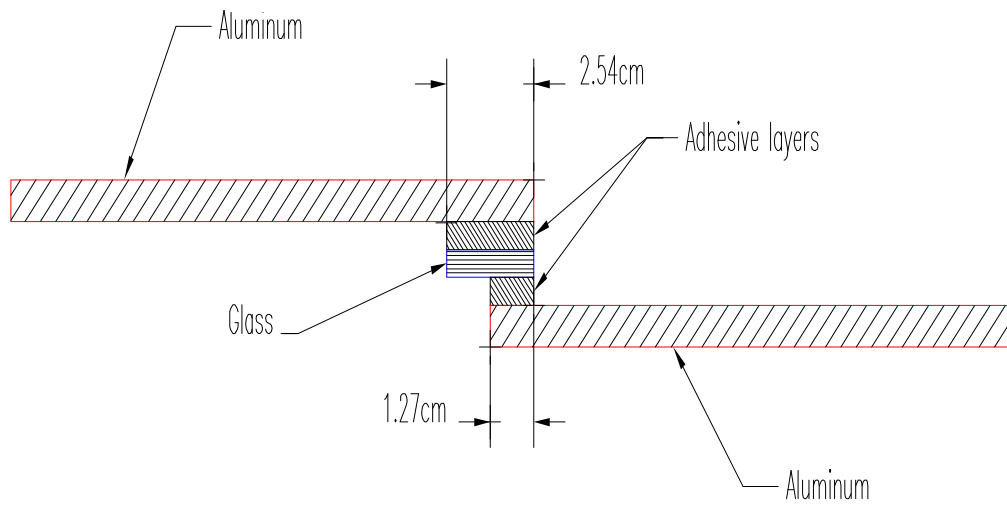

FIGURE 1D. Assembly of shear specimens.

APPENDIX E

SEALING COMPOUND, SINGLE-COMPONENT, NON-CURING, POLYSULFIDE BASE

E.1. SCOPE

E.1.1 Scope. This appendix covers single-component black, inert, thermoplastic, mastic, non-curing, sealing compounds. The service temperature of the sealing compounds are -40°C to 82°C (-40° to 180°F) (see E.6.1). This Appendix is a mandatory part of the specification. The information contained herein is intended for compliance.

E.1.2 Classification. Sealing compound shall be furnished as follows:

Type I - For static sealing of metal, glass, Polyacrylic plastics to each other and in combinations with each other.

E.2. APPLICABLE DOCUMENTS

E.2.1 General. The documents listed in this section are needed to meet the requirements specified in sections 3, 4, and 5 of this specification. This section does not include documents in other sections of this specification or recommended for additional information or as examples. While every effort has been made to ensure the completeness of this list, document users are cautioned that they must meet all requirements documents cited in sections 3, 4, and 5 of this specification, whether or not they are listed.

E.2.2 Non-Government publications. The following documents form a part of this document to the extent specified herein. Unless otherwise specified, the issues of the documents which are DoD adopted are those listed in the issue of the DODISS cited in the solicitation. Unless otherwise specified, the issues of documents not listed in the DODISS are the issues of the documents cited in the solicitation (see E.6.2).

AMERICAN NATIONAL STANDARDS INSTITUTE (ANSI)

ANSI/SAE AMS 4077 - Aluminum Alloy Sheet and Plate

(Application for copies should be addressed to American National Standards Institute, 11 West 42nd Street, New York, NY 10036.)

AMERICAN SOCIETY FOR TESTING AND MATERIALS (ASTM)
ASTM D217 - Cone Penetration of Lubricating Grease

APPENDIX E

- ASTM D471 - Rubber Property - Effect of Liquids
- ASTM D897 - Tensile Properties of Adhesive Bonds
- ASTM D4397- Polyethylene Sheeting for Construction Industrial, and Agricultural Applications
- ASTM E437 - Industrial Wire Cloth and Screens (Square Opening Series)
- ASTM D 4802- Poly(Methyl Methacrylate) Acrylic Plastic Sheet

(Application for copies should be addressed to American Society for Testing and Materials, 100 Barr Harbor Drive, West Conshohocken, PA 19428-2959.) (See contract provisions for additional precedence criteria).

E.2.3 Order of precedence. In the event of a conflict between the text of this document and the references cited herein, the text of this document takes precedence. Nothing in this document, however, supersedes applicable laws and regulations unless a specific exemption has been obtained. (See contract provisions for additional precedence criteria).

E.3. REQUIREMENTS

E.3.1 Material.

E.3.1.1 Sealing compound. Sealing compound should be a non-curing mastic organic polysulfide polymer. The sealing compound shall be homogeneous, stable, and noncorrosive.

E.3.2 Volatile content. The volatile content of sealing compound shall be not greater than 1.5 percent when tested as specified in E.4.5.1.

E.3.3 Water solubility. The water solubility of the sealing compound shall be not greater than 0.4 percent when tested as specified E.4.5.2.

E.3.4 Oil resistance. Sealing compound shall show no evidence of blistering, softening, or loss of adhesion when exposed to mineral oil and tested as specified in E.4.5.3.

E.3.5 Adhesion. Sealing compound shall have a bond strength of not less than 25 psi (1.75 kg/cm). Failure shall occur only in the sealing material itself when tested as specified in E.4.5.4.

E.3.6 Aging. When tested as specified in E.4.5.5, the sealing compound shall

APPENDIX E

show a depth of cone penetration before aging in 1/10mm of 40-80, after aging change in cone penetration in 1/10mm 20 MAX.

E.3.7 Effect of volatile compounds. There shall be no evidence of chemical attack such as crazing, pitting or etching on the surface of poly (methyl methacrylate) when exposed to volatile components of freshly prepared sealing compound and tested as specified in E.4.5.6.

E.3.8 Crazing on stressed acrylic plastic. Sealing compound shall not cause crazing or cracking of acrylic plastic under stress when tested as specified in E.4.5.7.

E.3.9 Low temperature flexibility. Sealing compound shall show no evidence of cracking or loss of adhesion when subjected to flexing at $-40^{\circ} \pm 1^{\circ}\text{C}$ ($-40^{\circ} \pm 2^{\circ}\text{F}$) and tested as specified in E.4.5.8.

E.3.10 Fluid resistance at elevated temperature. Sealing compound shall show no evidence of hardening, blistering, or any other deleterious property when tested as specified in E.4.5.9.

E.3.11 Water vapor permeability. When tested as specified in 4.5.10, the water vapor permeability rate of the sealing compound shall not be greater than 0.010 gm/hr/sq. in.

E.3.12 Color. The color shall be black (see E.4.5.11).

E.3.13 Toxicity. The materials shall not contain any asbestos, mercury or chromate compounds. The material shall have no adverse effects on the health of personnel when used for its intended purpose. Questions pertinent to this effect shall be referred by the contracting activity to the appropriate departmental medical service who will act as an advisor to the contracting agency (see E.4.5.12).

E.3.15 Material safety data sheet (MSDS). A MSDS shall be prepared for the sealing compound produced under this specification (see E.6.2).

E.4. VERIFICATION

E.4.1 General provisions. Unless otherwise specified in the contract or purchase order, the contractor is responsible for the performance of all inspection requirements (examinations and tests) as specified herein. Except as otherwise specified in the contract or purchase order, the contractor may use his own or any other facilities suitable for the performance of the inspection requirements specified

APPENDIX E

herein, unless disapproved by the Government. The Government reserves the right to perform any of the inspections set forth in this specification where such inspections are deemed necessary to ensure supplies and services conform to prescribed requirements.

E.4.2 Lot acceptance tests. A lot shall consist of all materials of the same type, from the same batch or blending operation, subjected to the same processing operations and conditions, produced by one manufacturer and offered for delivery at one time. Unless otherwise specified, for the purpose of lot acceptance tests, representative results shall be reported from the results obtained on a frequency basis for grades of sealing compound which are monitored using process control systems and procedures which insure no defects and shall be the basis for acceptance or rejection of the lot. Lot acceptance tests shall consist of the test indicated in Table IIE.

TABLE IIE. Lot acceptance test requirements.

<u>REQUIREMENTS</u>		
<u>CHARACTERISTIC</u>	<u>TYPE I</u>	<u>TEST METHOD</u>
Volatile Content	3.2	4.5.1
Water solubility	3.3	4.5.2
Oil resistance	3.4	4.5.3
Adhesion	3.5	4.5.4
Aging	3.6	4.5.5
Effect of volatile compounds	3.7	4.5.6
Crazing	3.8	4.5.7
Low temperature flexibility	3.9	4.5.8
Fluid resistance	3.10	4.5.9
Water vapor permeability	3.11	4.5.10
Color	3.12	4.5.11
Toxicity	3.13	4.5.12

E.4.3 Sampling.

E.4.3.1 Sampling for examination of sealing compound. Unless otherwise specified a random sample of filled containers shall be selected in accordance with attributes sampling inspection level II.

APPENDIX E

E.4.3.2 Sampling for tests. A sample consisting on 1 qt (0.95 liter) of sealant, representative of the lot shall be selected and placed in a wide-mouth, glass, 1 qt (0.95 liter) container and sealed tightly.

E.4.4 Examination.

E.4.4.1 Examination of sealing compound. Sample units of sealing compound selected in accordance with E.4.3.1 shall be examined for defects listed in Table IIIE. Sampling plan acceptance and rejection numbers apply collectively to all characteristics.

TABLE IIIE. Classification of defects in sealing compound.

Classification of defect	Defect	Method of inspection
Major 101	Evidence of settling or separation (see E.3.1)	Visual
Major 102	Milling and blending not as specified (see E.3.1)	Visual
Major 103	Evidence of corrosion on inside of containers (see E.3.1)	Visual
Major 107	Evidence of foreign matter (see E.3.14)	Visual

E.4.4.2 Cleaning on test panels. Except where otherwise specified herein, metal panels shall be cleaned with lint-free cheesecloth using an acceptable non-toxic solvent.

E.4.5 Tests.

E.4.5.1 Volatile content. Weigh a 2 by 4 inch (5.0 by 10.1 cm) aluminum panel to the nearest 0.001 g. Approximately 2 g of the sealing compound shall be spread uniformly to approximately 0.0625 in. (1.5 mm) thick on one side of the panel. The panel with the compound shall be weighed and then placed in an oven at $65.5^{\circ} \pm 1^{\circ}\text{C}$ ($150 \pm 2^{\circ}\text{F}$) for two hours. The panel with the compound shall then be reweighed. The loss in weight divided by the weight of the original coating multiplied by 100 shall constitute the percent of volatile content. Tests shall be performed in duplicate. Failure of either sample shall be cause for rejection of the lot (see E.3.2).

E.4.5.2 Water solubility. The panels used in determining volatile content shall be immersed in distilled water and heated at $65.5^{\circ} \pm 1^{\circ}\text{C}$ ($150^{\circ} \pm 2^{\circ}\text{F}$) for 4 hours. They shall then be removed and dried at $65.5^{\circ} \pm 1^{\circ}\text{C}$ ($150^{\circ} \pm 2^{\circ}\text{F}$) for 4 hours. The loss in weight divided by the weight of the coating after determination of the volatile content

APPENDIX E

and multiplied by 100 shall constitute the percent of water soluble material. Failure of the sample shall be cause for rejection of the lot (see E.3.3).

E.4.5.3 Oil resistance. Approximately 2 g of the sealing compound shall be spread uniformly on one side of a 1 by 4 in. (2.5 by 10.1 cm) aluminum panel. The aluminum shall be solvent degreased before immersing in 3% alkaline cleaner (90% sodium metasilicate and 10% Aerosol OT-B) at 80°C (176°F) for 5 minutes, washing in running tap water, immersing in dichromate solution (85 grams of sodium dichromate, not less than 99% by weight, and 250 ml of concentrated sulfuric acid, 93% by weight min. to 2 liters of distilled water) at 75°C (167°F) for 5 minutes, washing in running tap water and distilled water and drying. The sample shall then be partially immersed for 96 hours in oil conforming to Oil No. 2 (ASTM D471). The test shall be conducted at room temperature. The panel shall be removed and the sample examined for evidence of blistering, softening and lack of adhesion. Test shall be performed in duplicate. Failure of either sample shall be cause for rejection of the lot (see E.3.4).

E.4.5.4 Adhesion. Test shall be made as described in ASTM D897 except that there shall be 3 types of specimens: (a) steel specimens as described in ASTM D897; (b) steel specimens with a thin glass wafer bonded with suitable adhesive (epoxy resin base) to the steel working surfaces; (c) steel specimen with a polyacrylic plastic (conforming to ASTM D4802) wafer bonded to the working surface. The sealing compound shall be applied to both surfaces. The specimen shall be compressed under a load of 200 lb. (90 kg) for about 20 seconds to insure a minimum gap between the adherents of the specimen. The prepared specimen shall be conditioned at room temperature 22° - 25°C (72° - 77°F) for 49 hours prior to testing. The bond strength of the assembly shall be measured in a tensile testing machine whose jaw separation speed is 1-in. per minute. The specimens shall be examined for failure in cohesion of the sealing material. Test shall be performed in duplicate. Failure of the sample shall be cause for rejection of the lot (see E.3.5).

E.4.5.5 Aging. The consistency of the sealing compound shall be determined in the original condition and after aging for 24 hours at 65° ± 1°C (150° ± 2°F). The sample shall be tested in accordance with ASTM D217 tested for unworked penetration, using a 150 g total load for 5 seconds. Four readings shall be taken on each sample. More than one unsatisfactory reading shall be cause for rejection of the lot (see E.3.6).

E.4.5.6 Effect of volatile components. A 5-6 g sample of the sealing compound shall be placed on a 2 in. (5.0 cm) diameter watch glass and then placed in an enclosed vessel which contains a polished polymethylmethacrylate (conforming to

APPENDIX E

ASTM D4802) window as shown on figure IE. The test fixture shall be placed in an oven at $71^{\circ}\pm 1^{\circ}\text{C}$ ($160^{\circ}\pm 2^{\circ}\text{F}$) for 3 hours, then removed and allowed to cool to a temperature of approximately 38°C (100°F). The outer surface of the polymethylmethacrylate window shall be cooled by placing a piece of dry ice having a flat size of about 0.5 in onto the window of the fixture and allowing it to remain in contact with the window until condensation is observed on the inner surface of the window or for a period not greater than 20 minutes. The fixture shall then be allowed to remain at room temperature for a period of 2 hours. The window of the fixture shall be removed and its inner surface washed with tap water and wiped with a soft cloth. The surface shall then be examined with the aid of a 10-power magnifier in the area where condensation had formed for visual evidence of crazing, pitting, or etching. Visual examination shall be done by viewing perpendicular to the surface and then at an angle of 30 to 45° to the surface. Tests shall be performed in duplicate. Failure of either sample shall be cause for rejection of the lot (see E.3.7).

E.4.5.7 Crazing on stressed acrylic plastic. A piece of acrylic sheet plastic in accordance with ASTM D4802 shall be set up as a cantilever beam under load, as shown in figure 2E. After the beam has been loaded for 10 minutes and while still under load, the compound shall be applied to the top (tension) side of the plastic specimen two inches from the clamped end and directly above the support and allowed to remain an additional 10 minutes under load. The acrylic plastic sheet shall be examined with the aid of a 10 power magnifier for visual evidence of crazing or other attack while under stress. Visual examination shall be done by viewing perpendicular to the surface and then at an angle of 30 to 45° to the surface. Visual evidence of crazing or other attack while under stress constitutes failure of this test. Failure of the test shall be cause for rejection of the lot (see E.3.8).

E.4.5.8 Low temperature flexibility. Two panels, 1 by 6 by 0.030 in. (2.5 by 15.2 by 0.07 cm) of aluminum surfaced aluminum alloy, ANSI/SAE AMS 4077, shall be coated on one side with the sealing compound to a thickness of 0.03 in. (0.07 cm). The panels shall then be immersed for 48 hours at $38^{\circ}\pm 1^{\circ}\text{C}$ ($100^{\circ}\pm 2^{\circ}\text{F}$) in a non-toxic electro-optical grade solvent (ie OptiClear or equivalent). At the completion of the immersion period, the panels and the flexibility jig (figure 3E), shall be subjected to a temperature of $-40^{\circ}\pm 1^{\circ}\text{C}$ ($-40^{\circ}\pm 2^{\circ}\text{F}$) for two hours. While at this temperature, one end of the test panel shall be placed in the slotted position and the other bent around the curved portion of the flexibility test jig, at a steady uniform rate such that 3 seconds are required to complete the bend. The panels shall be removed and examined. Failure of either panel shall be cause for rejection of the lot (see E.3.9).

E.4.5.9 Fluid resistance at elevated temperatures. Two panels, 3 by 5 inches (7.6 by 12.7 cm) of aluminum surfaced alloy conforming to ANSI/SAE AMS 4077 shall be

APPENDIX E

coated on one side with the sealing compound to a thickness of (0.0625 in. (0.16 cm)). The panels shall be immersed for 48 hours at $38^{\circ}\text{C} \pm 1^{\circ}\text{C}$ ($100^{\circ} \pm 2^{\circ}\text{F}$) in so that one half of the material is above the liquid level. The panels shall then be removed, air dried for 24 hours, and baked at $82^{\circ} \pm 1^{\circ}\text{C}$ ($180^{\circ} \pm 2^{\circ}\text{F}$) for 72 hours. The panels shall then be examined for changes in film properties. Visible evidence of change in the film property shall constitute failure of this test. Failure of the sample shall be cause for rejection of the lot (see E.3.10).

E.4.5.10 Water vapor permeability. A sufficient amount of sealing compound shall be pressed between two sheets of polyethylene film (0.003-0.004 inches thick), according to ASTM D4397 to form a film about 0.075 in. (0.19 cm) thick and 2 in. (5.0 cm) in diameter. One of the polyethylene sheets shall be peeled off and a suitable size screen which shall retain the sealing compound shall be placed on the sealing compound. Use 2.5 inch (6.3 cm) diameter 30 mesh plain weave screening with 0.010 inch (0.025 m) diameter wire made of type 5056 aluminum or brass, according to ASTM E437. The polyethylene sheet shall be placed on the screen and the assembly shall be compressed until the overall thickness of the sealing compound and the screen is 0.064 ± 0.002 in. (0.16 ± 0.01 cm). The polyethylene sheets shall be removed and the screen-supported film shall be trimmed to size and placed in a position as shown in figure 4E. 5 ml of distilled water shall be placed in a Petri dish. The two metal plates holding the film of sealing compound and the Petri dish shall be screwed tightly to insure a good seal between the edge of the Petri dish and the sealing material (see E.3.11).

E.4.5.10.1 Assemblies. Two assemblies shall be prepared as described in E.4.5.10. A third assembly shall be prepared in the same manner except that no water shall be placed in the Petri dish. The three assemblies shall be weighed to the nearest 0.001 grams and then placed in an oven at $71^{\circ} \pm 1^{\circ}\text{C}$ ($160^{\circ} \pm 2^{\circ}\text{F}$) for 4 hours. The loss in weight of the dry assembly shall be subtracted from the weight of each of the other two assemblies. The water vapor transmission rates shall be calculated in units of g of water/hr/in.² of open area. The open area is the area of the 1.875 in-hole in the metal plate minus the area occupied by the wires of the screen within the hole. Failure of either sample shall be cause for rejection of the lot. Percent of water vapor is calculated as follows:

$$\frac{\text{wt of (sample + water + dish)} \times 100}{\text{wt of dish}}$$

conducted at 1 hr intervals until constant weight.

E.4.5.11 Color. The material shall be visually examined for conformance to color

APPENDIX E

requirements (see E.3.12).

E.4.5.12 Toxicity. The supplier shall furnish the toxicological data and formulations required to evaluate the safety of the material for the proposed use (see E.3.13).

E.5 PACKAGING

This section is not applicable to this appendix.

E.6 NOTES

(This section contains information of a general or explanatory nature that may be helpful, but is not mandatory.)

E.6.1 Intended use. The sealing compounds covered by this specification are intended for use in sealing metal to metal, glass to metal and acrylic to metal and for general purpose as deemed necessary by the using activity. This material is not to be used as an integral fuel tank or pressure cabin sealant.

E.6.2 Acquisition requirements. Acquisition documents must specify the following:

- a. Title, number and date of this specification.
- b. Issue of DODISS to be cited in the solicitation, and, if required, the specific issue of individual documents referenced (see E.2.1.1).
- c. Requirements for submission of first article sample.
- d. Applicable stock number.
- e. Packaging requirements, if other than specified in Section E.5.
- f. Serialization requirements, if applicable.
- g. Certificate of conformance for each lot or shipment of product.
- h. For the format and content of the MSDS consult FED-STD-313 Material Safety Data Sheets, preparation and the submission of.

APPENDIX E

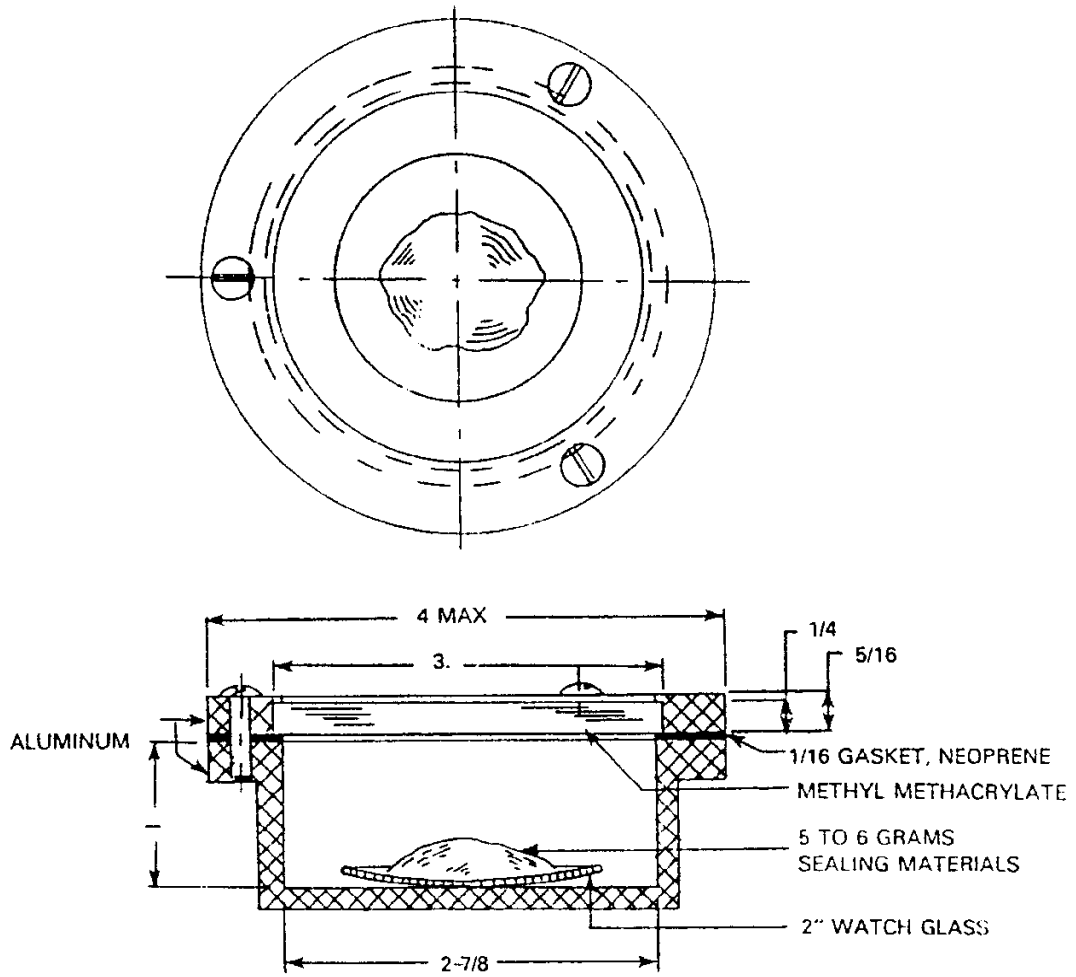

FIGURE 1E. Assembly for test on effect of volatile components.
(dimensions in inches)

APPENDIX E

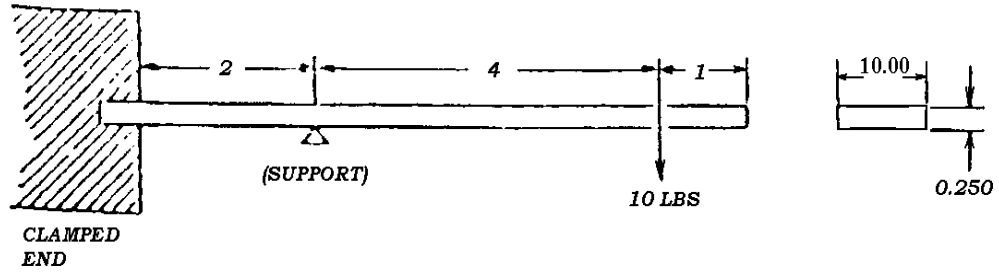
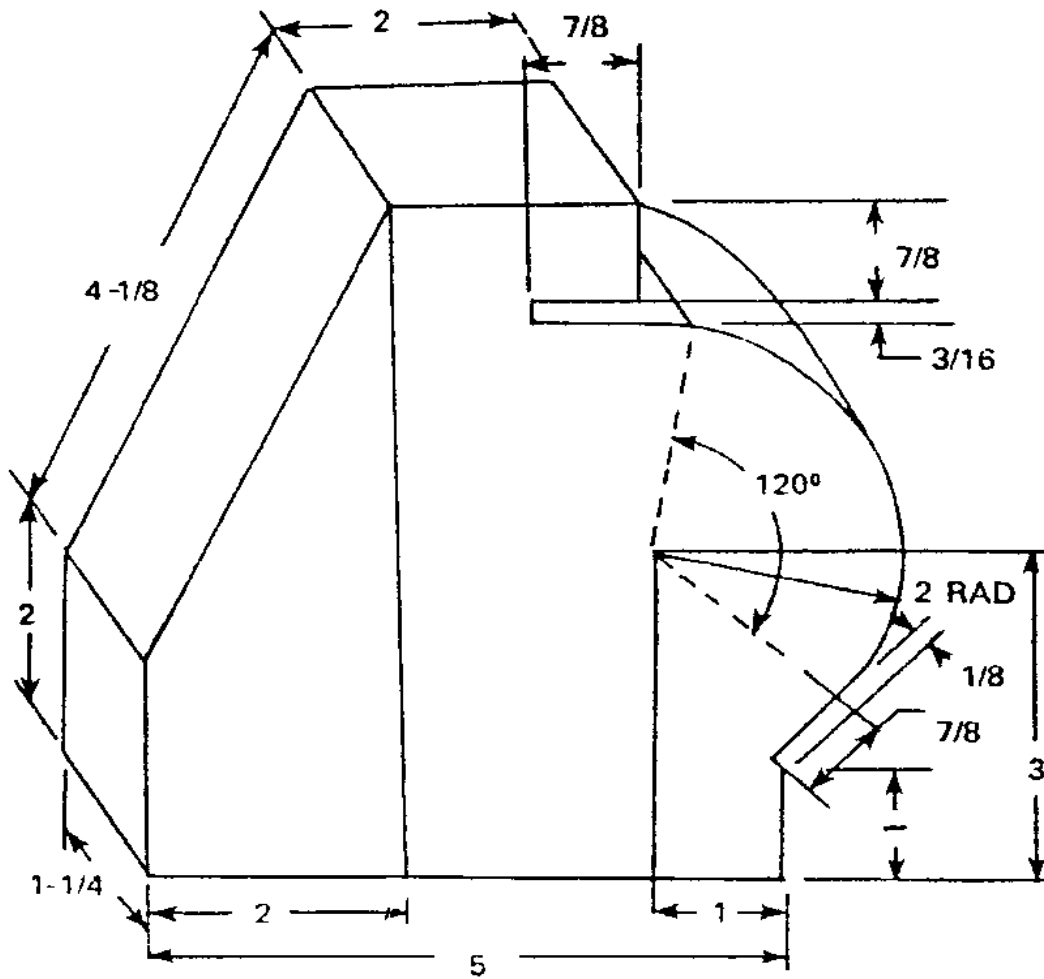

FIGURE 2E. Stress crazing test
(dimensions in inches)

APPENDIX E



MARERIAL: MAPLE WOOD

FIGURE 3E. Low temperature flexibility test jig.
(dimensions in inches)

MIL-PRF-13830B

APPENDIX E

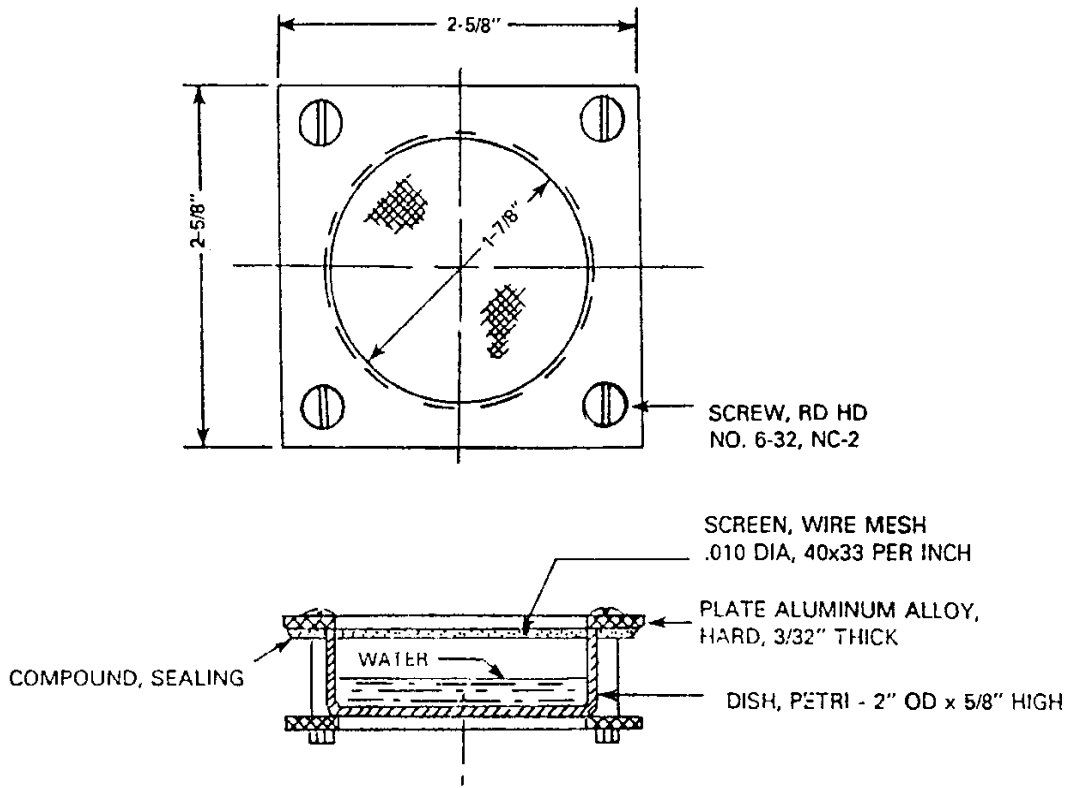

NOTE: TOP & BOTTOM PLATES ARE IDENTICAL, EXCEPT THAT
SCREW HOLES ARE TAPPED INTO BOTTOM PLATE

FIGURE 4E. Assembly for water vapor permeability test.
(dimensions in inches)

MIL-PRF-13830B

CONCLUDING MATERIAL

Custodian:
Army-AR
Navy-OS

Preparing activity:
Army-AR

(Project: 6650-0201)

STANDARDIZATION DOCUMENT IMPROVEMENT PROPOSAL

INSTRUCTIONS

1. The preparing activity must complete blocks 1, 2, 3, and 8. In block 1, both the document number and revision letter should be given.
2. The submitter of this form must complete blocks 4, 5, 6, and 7.
3. The preparing activity must provide a reply within 30 days from receipt of the form.

NOTE: This form may not be used to request copies of documents, nor to request waivers, or clarification of requirements on current contracts. Comments submitted on this form do not constitute or imply authorization to waive any portion of the referenced documents(s) or to amend contractual requirements.

I RECOMMEND A CHANGE:

1. DOCUMENT NUMBER

MIL-PRF-13830B

2. DOCUMENT DATE (YYMMDD)

970109

3. DOCUMENT TITLE

Optical Components for Fire Control Instruments; General Specification Governing the Manufacture, Assembly, and Inspection of

4. NATURE OF CHANGE *(Identify paragraph number and include proposed rewrite, if possible. Attach extra sheets as needed.)*

5. REASON FOR RECOMMENDATION

6. SUBMITTER

a. NAME *(Last, First, Middle Initial)*

b. ORGANIZATION

c. ADDRESS *(Include Zip Code)*

d. TELEPHONE *(Include Area Code)*
 (1) Commercial
 (2) AUTOVON
(if applicable)

7. DATE SUBMITTED
 (YYMMDD)

8. PREPARING ACTIVITY

a. NAME

U. S. Army ARDEC

b. TELEPHONE *(Include Area Code)*
 (1) Commercial
 (2) AUTOVON
 (201) 724-6671

(2) AUTOVON
 880-6671

c. ADDRESS *(Include Zip Code)*

ATTN: AMSTA-AR-EDE-S, B-12
 Picatinny Arsenal, NJ 07806-5000

IF YOU DO NOT RECEIVE A REPLY WITHIN 45 DAYS, CONTACT:
 Defense Quality and Standardization Office
 5203 Leesburg Pike, Suite 1403, Falls Church, VA 22041-3466
 Telephone (703) 756-2340 AUTOVON 289-2340