

Marra Forni

PRODUCT CATALOG

[®]
Marra Forni





Scan to visit
www.marraforni.com

Updated December 2018
Prices Subject to Change Without Notice.

A Letter to Our Customers

Marra Forni boasts the most complete pizzeria and restaurant equipment line on the market. Our ovens feature a refractory brick core that is superior to cement, due to its ability to expand and contract with temperature fluctuations of the oven. This flexibility means that your Marra Forni deck will withstand years of use without cracking. Our signature dough mixers and pasta machine come in a wide range of capacities. Marra prep tables afford a tidy work surface and a multitude of options for customizing. Available in two- or three-door models, our preps can be fitted with a granite counter and backsplash for a sophisticated finish. The doors are sized to fit the included dough boxes. We also feature glass condiment rails which affix to the top of the station to avoid taking up valuable counter space.

We stand behind our equipment and guarantee your satisfaction in the purchase of every product. Visit marraforni.com for additional information and printable specs sheets. As always, please feel free to contact us via email at inquiries@marraforni.com, or call 888.239.0575.

The logo for Marra Forni, featuring the brand name in a red, cursive script font. The word "Marra" is written above "forni", and the entire name is underlined with a red line.

Marra Forni Neapolitan 90, 110, 130, 140, 150

Gas Models: between 8" W.C to 10"W.C



Standard Tile Color Options



Standard Facade Options
- Stainless Steel or Black

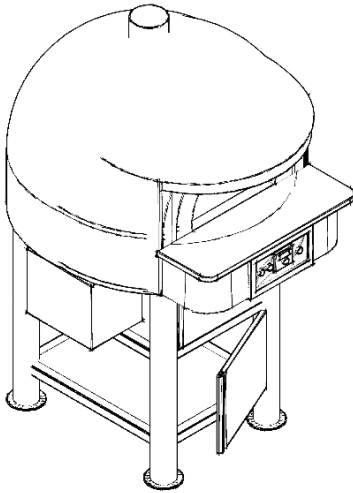

Wood Burning Models

Marra Forni 90 (NP90W*)

Marra Forni 110 (NP110W*)

Marra Forni 130 (NP130W*)

Marra Forni 140 (NP140W*)

Marra Forni 150 (NP150W*)

Gas Converted Models

Marra Forni 90 (NP90G*)

Marra Forni 110 (NP110G*)

Marra Forni 130 (NP130G*)

Marra Forni 140 (NP140G*)

Marra Forni 150 (NP150G*)

Ovens include standard tile colors Red, White, Brown, Blue or Black. For an additional cost, you may choose your own custom tile, spell text of your choice onto the facade of your oven in tile, upgrade to a stainless steel stand, or apply black powder coating to the metal facade or oven stand. Optional casters available upon request. With casters, a quick-disconnect gas hose must be used.

Quick Specs	Neapolitan 90*	Neapolitan 110*	Neapolitan 130*	Neapolitan 140*	Neapolitan 150*
Height	76"	81.5"	81.5"	81.5"	81.5"
Width	48.68"	68.38"	64.43"	68.37"	72.31"
Depth	56.18"	66.24"	71.93"	75.87"	79.81"
Cooking Surface	6.56 sq. ft.	10.2 sq. ft.	14.5 sq. ft.	16.36 sq. ft.	18.96 sq. ft.
BTUs (NAT)	84,000	84,000	84,000	84,000	84,000
AMPs	120V / 12AMPs	120V / 12AMPs	120V / 12AMPs	120V / 12AMPs	120V / 12AMPs
NPT	3/4"	3/4"	3/4"	3/4"	3/4"
Oven Weight	1,850 lbs.	3,100 lbs.	3,462 lbs.	4,400 lbs.	4,500 lbs.
Crated Weight	2,150 lbs.	3,400 lbs.	4,524 lbs.	4,800 lbs.	4,900 lbs.
Crate W x D x H	73" x 63" x 82"	73" x 83" x 87"	96" x 83" x 87"	96" x 83" x 90"	96" x 87" x 82"
Pizza Capacity 8"	4-5	11-12	14-16	14-16	16-18
Pizza Capacity 10"	3-4	8-9	12-14	12-14	14-16
Pizza Capacity 12"	2-3	6-7	8-9	10-12	12-14

*Denotes Internal Model Number of the Oven. Oven sizes refer to dome interior size. All ovens Freight Class 85.

Marra Forni Neapolitan 90

Neapolitan 90 (MF.NP90G) Gas Model, also available as "MF.NP90W" Wood-Fired.



*Tile work shown in photo is customized. Please ask for more information about tile options.



This oven is available in standard tile finishes of Red, White, Brown, Blue or Black at no additional cost. There is a \$4 per square foot net deduction per oven if you choose to use custom tile.

Features

- Refractory brick with 4" of layered insulation in the dome, 8" in the deck.
- Fire-rated tile exterior over clay dome
- 35.43 inch / 90 cm - diameter deck
- Oven mouth measures 18" x 9"
- 6" diameter S/S flue collar
- Turbo Burner
- 14" landing at the opening
- 3 year deck warranty
- Mechanical Thermostat (0 - 1000°F)

Gas Requirements

- 120V / Single Phase/ 12AMPs
- 84,000 BTUs per burner
- 1 gas connection 3/4" NPT NPT per burner
- The oven is vented through an 6" round flue collar interconnected to an exhaust system integral with the oven hearth. The Neapolitan gas-fired oven can be direct vented via a grease rated chimney or with a listed type 1 exhaust hood (or equivalent).

Optional casters available upon request. A quick-disconnect gas hose must be used with casters.

Quick Specs	Neapolitan 90
Height	76"
Width	48.68"
Depth	56.18"
Cooking Surface	6.56 sq. ft.
BTUs (NAT)	84,000
AMPs	120V / 12AMPs
NPT	3/4"
Oven Weight	1,850 lbs.
Crated Weight	2,150 lbs.
Crate W x D x H	73" x 63" x 82"
Pizza Capacity 8"	4-5
Pizza Capacity 10"	3-4
Pizza Capacity 12"	2-3
Pizza Capacity 16"	1-2

*Oven sizes refer to dome interior size. All ovens Freight Class 85 and ETL, and VPN approved. Oven must be shipped LTL.

Marra Forni Neapolitan 110

Neapolitan 110 (MF.NP110G) Gas Model, also available as "MF.NP110W" Wood-Fired.



*Tile work shown in photo is customized. Please ask for more information about tile options.



This oven is available in standard tile finishes of Red, White, Brown, Blue or Black at no additional cost. There is a \$4 per square foot net deduction per oven if you choose to use custom tile.

Features

- Refractory brick with 4" of layered insulation in the dome, 8" in the deck.
- Fire-rated tile exterior over clay dome
- 43.31 inch / 110 cm - diameter deck
- Oven mouth measures 18" x 9"
- 8" diameter S/S flue collar
- Turbo Burner
- 14" landing at the opening
- 3 year deck warranty
- Mechanical Thermostat (0 - 1000°F)

Gas Requirements

- 120V / Single Phase/ 12AMPs
- 84,000 BTUs per burner
- 1 gas connection 3/4" NPT per burner
- The oven is vented through an 8" round flue collar interconnected to an exhaust system integral with the oven hearth. The Neapolitan gas-fired oven can be direct vented via a grease rated chimney or with a listed type 1 exhaust hood (or equivalent).

Quick Specs	Neapolitan 110
Height	81.5"
Width	68.38"
Depth	66.24"
Cooking Surface	10.2 sq. ft.
BTUs (NAT)	84,000
AMPs	120V / 12AMPs
NPT	3/4"
Oven Weight	3,100 lbs.
Crated Weight	3,400 lbs.
Crated W x D x H	73" x 83" x 87"
Pizza Capacity 8"	11-12
Pizza Capacity 10"	8-9
Pizza Capacity 12"	6-7
Pizza Capacity 16"	3-4

Optional casters available upon request. A quick-disconnect gas hose must be used with casters.

*Oven sizes refer to dome interior size. All ovens Freight Class 85 and ETL, and VPN approved. Oven must be shipped LTL.

Marra Forni Neapolitan 130

Neapolitan 130 (MF.NP150G) Gas Model, also available as "MF.NP150W" Wood-Fired.



*Tile work shown in photo is customized. Please ask for more information about tile options.



This oven is available in standard tile finishes of Red, White, Brown, Blue or Black at no additional cost. There is a \$4 per square foot net deduction per oven if you choose to use custom tile.

Features

- Refractory brick with 4" of layered insulation in the dome, 8" in the deck.
- Fire-rated tile exterior over clay dome
- 51.18 inch / 130 cm - diameter deck
- Oven mouth measures 24" x 9.5"
- 8" diameter S/S flue collar
- Turbo Burner
- 14" landing at the opening
- 3 year deck warranty
- Mechanical Thermostat (0 - 1000°F)

Gas Requirements

- 120V / Single Phase/ 12AMPs
- 84,000 BTUs per burner
- 1 gas connection 3/4" NPT per burner
- The oven is vented through an 8" round flue collar interconnected to an exhaust system integral with the oven hearth. The Neapolitan gas-fired oven can be direct vented via a grease rated chimney or with a listed type 1 exhaust hood (or equivalent).

Optional casters available upon request. A quick-disconnect gas hose must be used with casters.

Quick Specs	Neapolitan 130
Height	81.5
Width	64.43"
Depth	71.93"
Cooking Surface	14.5 sq. ft.
BTUs (NAT)	84,000
AMPs	120V / 12AMPs
NPT	3/4"
Oven Weight	3,462 lbs.
Crated Weight	4,524 lbs.
Crated W x D x H	96" x 83" x 87"
Pizza Capacity 8"	14-16
Pizza Capacity 10"	12-14
Pizza Capacity 12"	8-9
Pizza Capacity 16"	3-4

*Oven sizes refer to dome interior size. All ovens Freight Class 85 and ETL, and VPN approved. Oven must be shipped LTL.

Marra Forni Neapolitan 140

Neapolitan 140 (MF.NP140G) Gas Model, also available as "MF.NP140W" Wood-Fired.



*Tile work shown in photo is customized. Please ask for more information about tile options.



This oven is available in standard tile finishes of Red, White, Brown, Blue or Black at no additional cost. There is a \$4 per square foot net deduction per oven if you choose to use custom tile.

Features

- Refractory brick with 4" of layered insulation in the dome, 8" in the deck.
- Fire-rated tile exterior over clay dome
- 55.12 inch / 140 cm - diameter deck
- Oven mouth measures 24" x 9.5"
- 8" diameter S/S flue collar
- Turbo Burner
- 14" landing at the opening
- 3 year deck warranty
- Mechanical Thermostat (0 - 1000°F)

Gas Requirements

- 120V / Single Phase/ 12AMPs
- 84,000 BTUs per burner
- 1 gas connection 3/4" NPT per burner
- The oven is vented through an 8" round flue collar interconnected to an exhaust system integral with the oven hearth. The Neapolitan gas-fired oven can be direct vented via a grease rated chimney or with a listed type 1 exhaust hood (or equivalent).

Quick Specs	Neapolitan 140
Height	81.5"
Width	68.37"
Depth	75.87"
Cooking Surface	16.36 sq. ft.
BTUs (NAT)	84,000
AMPs	120V / 12AMPs
NPT	3/4"
Oven Weight	4,400 lbs.
Crated Weight	4,800 lbs.
Crated W x D x H	96" x 83" x 90"
Pizza Capacity 8"	14-16
Pizza Capacity 10"	12-14
Pizza Capacity 12"	10-12
Pizza Capacity 16"	6-7

Optional casters available upon request. A quick-disconnect gas hose must be used with casters.

*Oven sizes refer to dome interior size. All ovens Freight Class 85 and ETL, and VPN approved. Oven must be shipped LTL.

Marra Forni Neapolitan 150

Neapolitan 150 (MF.NP150G) Gas Model, also available as "MF.NP150W" Wood-Fired.



*Tile work shown in photo is customized. Please ask for more information about tile options.



This oven is available in standard tile finishes of Red, White, Brown, Blue or Black at no additional cost. There is a \$4 per square foot net deduction per oven if you choose to use custom tile.

Features

- Refractory brick with 4" of layered insulation in the dome, 8" in the deck.
- Fire-rated tile exterior over clay dome
- 59.06 inch / 150 cm - diameter deck
- Oven mouth measures 26" x 9.5"
- 8" diameter S/S flue collar
- Turbo Burner
- 14" landing at the opening
- 3 year deck warranty
- Mechanical Thermostat (0 - 1000°F)

Gas Requirements

- 120V / Single Phase/ 12AMPs
- 84,000 BTUs per burner
- 1 gas connection 3/4" NPT per burner
- The oven is vented through an 8" round flue collar interconnected to an exhaust system integral with the oven hearth. The Neapolitan gas-fired oven can be direct vented via a grease rated chimney or with a listed type 1 exhaust hood (or equivalent).

Quick Specs	Neapolitan 150
Height	81.5"
Width	72.31"
Depth	79.81"
Cooking Surface	18.96 sq. ft.
BTUs (NAT)	84,000
AMPs	120V / 12AMPs
NPT	3/4"
Oven Weight	4,500 lbs.
Crated Weight	4,900 lbs.
Crated W x D x H	96" x 87" x 82"
Pizza Capacity 8"	16-18
Pizza Capacity 10"	14-16
Pizza Capacity 12"	12-14
Pizza Capacity 16"	8-12

Optional casters available upon request. A quick-disconnect gas hose must be used with casters.

*Oven sizes refer to dome interior size. All ovens Freight Class 85 and ETL, and VPN approved. Oven must be shipped LTL.

Marra Forni Enclosed Facade Product List

Gas Models: between 8" W.C to 10"W.C



Wood Burning Models
Marra Forni 90 (EF90W*)
Marra Forni 110 (EF110W*)
Marra Forni 140 (EF140W*)
Marra Forni 150 (EF150W*)

Gas Converted Models
Marra Forni 90 (EF90G*)
Marra Forni 110 (EF110G*)
Marra Forni 140 (EF140G*)
Marra Forni 150 (EF150G*)

Maximize your kitchen space with an Enclosed Facade oven from Marra Forni. The oven is built directly into your wall and includes a wood storage area. The facade is available in our standard stainless steel finish at no additional cost. If you prefer black powder coating, please contact a sales representative.

Quick Specs	Facade 90*	Facade 110*	Facade 130*	Facade 140*	Facade 150*
Height	69.77"	69.77"	71.14"	71.14"	71.39"
Width	48.68"	56.56"	64.43"	68.37"	72.31"
Depth	54.18"	62.06"	69.93"	73.87"	73.87"
Cooking Surface	6.56 sq. ft.	9.86 sq. ft.	13.84 sq. ft.	16.36 sq. ft.	18.96 sq. ft.
BTUs (NAT)	84,000	84,000	84,000	84,000	84,000
AMPs	120V / 12AMPs	120V / 12AMPs	120V / 12AMPs	120V / 12AMPs	120V / 12AMPs
NPT	3/4"	3/4"	3/4"	3/4"	3/4"
Oven Weight	1,650 lbs.	1,650 lbs.	4,200 lbs.	4,200 lbs.	4,500 lbs.
Crated Weight	1,950 lbs.	1,950 lbs.	4,600 lbs.	4,600 lbs.	4,900 lbs.
Crate W x D x H	73" x 63" x 82"	73" x 63" x 82"	96" x 83" x 84"	96" x 83" x 82"	108" x 87" x 82"
Pizza Capacity 8"	4-5	7-8	9-10	10-12	14-16
Pizza Capacity 10"	3-4	6-7	8-9	9-11	12-14
Pizza Capacity 12"	2-3	4-6	7-8	8-10	10-12
Pizza Capacity 16"	1-2	3-4	4-6	6-7	7-8

*Denotes Internal Model Number of the Oven. Oven sizes refer to dome interior size. All ovens Freight Class 85.

Marra Forni Enclosed Facade 90

Facade 90 (MF.EF90G) Gas Model, also available as "MF.EF90W" Wood-Fired.



Drawing illustrates Enclosed Facade "Neapolitan"

This oven is available in our standard stainless steel facade finish at no additional cost. If you prefer black powder coating, please contact a sales representative at 888.239.0575.

Features

- Refractory brick with 4" of layered insulation in the dome, 8" in the deck.
- Enclosed Facade surrounds clay dome
- 35.43 inch / 90 cm - diameter deck
- Oven mouth measures 18" x 9"
- 6" diameter S/S flue collar
- Turbo Burner
- 12" landing at the opening
- 3 year deck warranty
- Mechanical Thermostat (0 - 1000°F)

Gas Requirements

- 120V / Single Phase/ 12AMPs
- 84,000 BTUs per burner
- 1 gas connection 3/4" NPT NPT per burner
- The oven is vented through an 6" round flue collar interconnected to an exhaust system integral with the oven hearth. The Neapolitan gas-fired oven can be direct vented via a grease rated chimney or with a listed type 1 exhaust hood (or equivalent).

Quick Specs	Facade 90
Height	69.77"
Width	48.68"
Depth	54.18"
Cooking Surface	6.56 sq. ft.
BTUs (NAT)	84,000
AMPs	120V / 12AMPs
NPT	3/4"
Oven Weight	1,650 lbs.
Crated Weight	1,950 lbs.
Crate W x D x H	73" x 63" x 82"
Pizza Capacity 8"	4-5
Pizza Capacity 10"	3-4
Pizza Capacity 12"	2-3
Pizza Capacity 16"	1-2

*Oven sizes refer to dome interior size. All ovens Freight Class 85 and ETL, and VPN approved. Oven must be shipped LTL.

Marra Forni Enclosed Facade 110

Facade 110 (MF.EF110G) Gas Model, also available as "MF.EF110W" Wood-Fired.



Drawing illustrates Enclosed Facade "Neapolitan"

This oven is available in our standard stainless steel facade finish at no additional cost. If you prefer black powder coating, please contact a sales representative at 888.239.0575.

Features

- Refractory brick with 4" of layered insulation in the dome, 8" in the deck.
- Enclosed Facade surrounds clay dome
- 43.31 inch / 110 cm - diameter deck
- Oven mouth measures 18" x 9"
- 8" diameter S/S flue adapter
- Turbo Burner
- 12" landing at the opening
- 3 year deck warranty
- Mechanical Thermostat (0 - 1000°F)

Gas Requirements

- 120V / Single Phase/12AMPs
- 84,000 BTUs per burner
- 1 gas connection 3/4" NPT NPT per burner
- The oven is vented through an 8" round flue collar interconnected to an exhaust system integral with the oven hearth. The Neapolitan gas-fired oven can be direct vented via a grease rated chimney or with a listed type 1 exhaust hood (or equivalent).

Quick Specs	Facade 110
Height	69.77"
Width	56.56"
Depth	62.06"
Cooking Surface	9.86 sq. ft.
BTUs (NAT)	84,000
AMPs	120V / 12AMPs
NPT	3/4"
Oven Weight	1,650 lbs.
Crated Weight	1,950 lbs.
Crated W x D x H	73" x 63" x 82"
Pizza Capacity 8"	7-8
Pizza Capacity 10"	6-7
Pizza Capacity 12"	4-6
Pizza Capacity 16"	3-4

*Oven sizes refer to dome interior size. All ovens Freight Class 85 and ETL, and VPN approved. Oven must be shipped LTL.

Marra Forni Enclosed Facade 130

Facade 140 (MF.EF140G) Gas Model, also available as "MF.EF140W" Wood-Fired.



Drawing illustrates Enclosed Facade "Neapolitan"

This oven is available in our standard stainless steel facade finish at no additional cost. If you prefer black powder coating, please contact a sales representative at 888.239.0575.

Features

- Refractory brick with 4" of layered insulation in the dome, 8" in the deck.
- Enclosed Facade surrounds clay dome
- 51.18 inch / 130 cm - diameter deck
- Oven mouth measures 24" x 9.5"
- 8" diameter S/S flue adapter
- Turbo Burner
- 12" landing at the opening
- 3 year deck warranty
- Mechanical Thermostat (0 - 1000°F)

Gas Requirements

- 120V / Single Phase/12 AMPs
- 84,000 BTUs per burner
- 1 gas connection 3/4" NPT per burner
- The oven is vented through an 8" round flue collar interconnected to an exhaust system integral with the oven hearth. The Neapolitan gas-fired oven can be direct vented via a grease rated chimney or with a listed type 1 exhaust hood (or equivalent).

Quick Specs	Facade 130
Height	71.14"
Width	64.43"
Depth	69.93"
Cooking Surface	13.84 sq. ft.
BTUs (NAT)	84,000
AMPs	120V / 12AMPs
NPT	3/4"
Oven Weight	4,200 lbs.
Crated Weight	4,600 lbs
Crated W x D x H	96"x 83"x 84"
Pizza Capacity 8"	9-10
Pizza Capacity 10"	8-9
Pizza Capacity 12"	7-8
Pizza Capacity 16"	4-6

*Oven sizes refer to dome interior size. All ovens Freight Class 85 and ETL, and VPN approved. Oven must be shipped LTL.

Marra Forni Enclosed Facade 140

Facade 140 (MF.EF140G) Gas Model, also available as "MF.EF140W" Wood-Fired.



Drawing illustrates Enclosed Facade "Neapolitan"

This oven is available in our standard stainless steel facade finish at no additional cost. If you prefer black powder coating, please contact a sales representative at 888.239.0575.

Features

- Refractory brick with 4" of layered insulation in the dome, 8" in the deck.
- Enclosed Facade surrounds clay dome
- 55.12 inch / 140 cm - diameter deck
- Oven mouth measures 24" x 9.5"
- 8" diameter S/S flue adapter
- Turbo Burner
- 12" landing at the opening
- 3 year deck warranty
- Mechanical Thermostat (0 - 1000°F)

Gas Requirements

- 120V / Single Phase/ 12AMPs
- 84,000 BTUs per burner
- 1 gas connection 3/4" NPT NPT per burner
- The oven is vented through an 8" round flue collar interconnected to an exhaust system integral with the oven hearth. The Neapolitan gas-fired oven can be direct vented via a grease rated chimney or with a listed type 1 exhaust hood (or equivalent).

Quick Specs	Facade 140
Height	71.14"
Width	68.37"
Depth	73.87"
Cooking Surface	16.36 sq. ft.
BTUs (NAT)	84,000
AMPs	120V / 12AMPs
NPT	3/4"
Oven Weight	4,200 lbs.
Crated Weight	4,600 lbs.
Crated W x D x H	96" x 83" x 82"
Pizza Capacity 8"	10-12
Pizza Capacity 10"	9-11
Pizza Capacity 12"	8-10
Pizza Capacity 16"	6-7

*Oven sizes refer to dome interior size. All ovens Freight Class 85 and ETL, and VPN approved. Oven must be shipped LTL.

Marra Forni Enclosed Facade 150

Facade 150 (MF.EF150G) Gas Model, also available as "MF.EF150W" Wood-Fired.



Drawing illustrates Enclosed Facade "Neapolitan"

This oven is available in our standard stainless steel facade finish at no additional cost. If you prefer black powder coating, please contact a sales representative at 888.239.0575.

Features

- Refractory brick with 4" of layered insulation in the dome, 8" in the deck.
- Enclosed Facade surrounds clay dome
- 59.06 inch / 150 cm - diameter deck
- Oven mouth measures 26" x 9.5"
- 8" diameter S/S flue adapter
- Turbo Burner
- 12" landing at the opening
- 3 year deck warranty
- Mechanical Thermostat (0 - 1000°F)

Gas Requirements

- 120V / Single Phase/ 12AMPs
- 84,000 BTUs per burner
- 1 gas connection 3/4" NPT per burner
- The oven is vented through an 8" round flue collar interconnected to an exhaust system integral with the oven hearth. The Neapolitan gas-fired oven can be direct vented via a grease rated chimney or with a listed type 1 exhaust hood (or equivalent).

Quick Specs	Facade 150
Height	71.39"
Width	72.31"
Depth	73.87"
Cooking Surface	18.96 sq. ft.
BTUs (NAT)	84,000
AMPs	120V / 12AMPs
NPT	3/4"
Oven Weight	4,500 lbs.
Crated Weight	4,900 lbs.
Crated W x D x H	108" x 87" x 82"
Pizza Capacity 8"	14-16
Pizza Capacity 10"	12-14
Pizza Capacity 12"	10-12
Pizza Capacity 16"	7-8

*Oven sizes refer to dome interior size. All ovens Freight Class 85 and ETL, and VPN approved. Oven must be shipped LTL.

Marra Forni Rotator RT 90, 110, 130, 150

Gas Models: between 8" W.C to 10" W.C



Standard Tile Color Options



Standard Facade Options
- Stainless Steel or Black



Rotator Gas/Wood Oven Models

Marra Forni 110 (RT110G)

Marra Forni 130 (RT130G)

Marra Forni 150 (RT150G)

Rotators operate on a combination Wood/Gas burner system.

Illustration of a free-standing Rotator oven prior to enclosure shown at left.

For an additional cost, upgrade to stainless steel or apply black powder coating to the metal facade.

Quick Specs	Rotator 90*	Rotator 110*	Rotator 130*	Rotator 150*
Height	81.5"	81.5	81.75"	71.39"
Width	60.5"	68.38"	76.45"	72.31"
Depth	58.5"	66.24"	74.12"	77.81"
Cooking Surface	6.8 sq. ft..	10.2 sq. ft..	14.3 sq. ft..	18.96 sq. ft.
BTUs (NAT)	84,000 / Burner	84,000 / Burner	84,000 / Burner	84,000
AMPs	120V / 12AMPs	120V / 12AMPs	120V / 12AMPs	120V / 12AMPs
NPT	3/4"	3/4"	3/4"	3/4"
Oven Weight	3,142 lbs.	3,666 lbs.	5,118 lbs.	4,500 lbs.
Crated Weight	3,542-3,690 lbs	4,372-4,720 lbs	5,240-5,628 lbs.	4,900 lbs.
Crate W x D x H	83" x 73" x 87"	83" x 73" x 86"	96" x 87" x 90"	108" x 87" x 82"
Pizza Capacity 8"	8	10	12	16
Pizza Capacity 10"	7	9	11	14
Pizza Capacity 12"	6	8	10	12
Pizza Capacity 16"	2	3	5	8

*Denotes Internal Model Number of the Oven. Oven sizes refer to dome interior size. All ovens Freight Class 85.

Marra Forni Rotator RT 90

Rotator RT 90 (MF.RT90G) Gas Model, also available as "MF.RT90W" Wood-Fired.



*Tile work shown in photo is custom and is not included in standard tile options.



This oven is available in standard tile finishes of Red, White, Brown, Blue or Black at no additional cost. There is a \$4 per square foot net deduction per oven if you choose to use custom tile.

Features

- Fire-rated tile exterior over clay dome
- 35.43 inch / 90 cm - diameter deck
- Oven mouth measures 24" x 9.5"
- 6" diameter S/S flue collar
- Turbo Burner
- 14" landing at the opening
- 2 year deck warranty
- Mechanical Thermostat (0 - 1000°F)

Gas Requirements

- 120V / Single Phase/ 12AMPs
- 84,000 BTUs per burner
- 1 gas connection 3/4" NPT NPT per burner
- The oven is vented through an 6" round flue collar interconnected to an exhaust system integral with the oven hearth. The Neapolitan gas-fired oven can be direct vented via a grease rated chimney or with a listed type 1 exhaust hood (or equivalent).

Quick Specs	Rotator 90
Height	81.5"
Width	60.5"
Depth	58.5"
Cooking Surface	6.8 sq. ft.
BTUs (NAT)	84,000 / Burner
AMPs	120V / 12AMPs
NPT	3/4"
Oven Weight	3,000 lbs.
Crated Weight	3,300 lbs.
Crated W x D x H	73" x 63" x 86"
Pizza Capacity 8"	10
Pizza Capacity 10"	8
Pizza Capacity 12"	6
Pizza Capacity 16"	3

*Oven sizes refer to dome interior size. All ovens Freight Class 85 and ETL, and VPN approved. Oven must be shipped LTL.

Marra Forni Rotator RT 110

Rotator RT 110 (MF.RT110G) Gas Model, also available as "MF.RT110W" Wood-Fired.



*Tile work shown in photo is custom and is not included in standard tile options.



This oven is available in standard tile finishes of Red, White, Brown, Blue or Black at no additional cost. There is a \$4 per square foot net deduction per oven if you choose to use custom tile.

Features

- Refractory brick with 4" of layered insulation in the dome, 8" in the deck.
- Fire-rated tile exterior over clay dome
- 43.31 inch / 110 cm - diameter deck
- Oven mouth measures 24" x 9.5"
- 8" diameter S/S flue collar
- Turbo Burner
- 14" landing at the opening
- 2 year deck warranty
- Mechanical Thermostat (0 - 1000°F)

Gas Requirements

- 120V / Single Phase/ 12AMPs
- 84,000 BTUs per burner
- 1 gas connection 3/4" NPT NPT per burner
- The oven is vented through an 8" round flue collar interconnected to an exhaust system integral with the oven hearth. The Neapolitan gas-fired oven can be direct vented via a grease rated chimney or with a listed type 1 exhaust hood (or equivalent).

Quick Specs	Rotator 110
Height	81.5"
Width	68.38"
Depth	66.24"
Cooking Surface	10.2 sq. ft.
BTUs (NAT)	84,000 / Burner
AMPs	120V / 12AMPs
NPT	3/4"
Oven Weight	4,600 lbs.
Crated Weight	4,900 lbs.
Crated W x D x H	82" x 73" x 86"
Pizza Capacity 8"	12
Pizza Capacity 10"	10
Pizza Capacity 12"	8
Pizza Capacity 16"	4-5

*Oven sizes refer to dome interior size. All ovens Freight Class 85 and ETL, and VPN approved. Oven must be shipped LTL.

Marra Forni Rotator RT 130

Rotator RT 130 (MF.RT130G) Gas Model, also available as "MF.RT130W" Wood-Fired.



*Tile work shown in photo is custom and is not included in standard tile options.



This oven is available in standard tile finishes of Red, White, Brown, Blue or Black at no additional cost. There is a \$4 per square foot net deduction per oven if you choose to use custom tile.

Features

- Refractory brick with 4" of layered insulation in the dome, 8" in the deck.
- Fire-rated tile exterior over clay dome
- 51.18 inch / 130 cm - diameter deck
- Oven mouth measures 26" x 9.5"
- 8" diameter S/S flue collar
- Turbo Burner
- 14" landing at the opening
- 2 year deck warranty
- Mechanical Thermostat (0 - 1000°F)

Gas Requirements

- 120V / Single Phase/ 12AMPs
- 84,000 BTUs per burner
- 1 gas connection 3/4" NPT NPT per burner
- The oven is vented through an 8" round flue collar interconnected to an exhaust system integral with the oven hearth. The Neapolitan gas-fired oven can be direct vented via a grease rated chimney or with a listed type 1 exhaust hood (or equivalent).

Quick Specs	Rotator 130
Height	81.75"
Width	76.45"
Depth	74.12"
Cooking Surface	14.3 sq. ft.
BTUs (NAT)	84,000 /Burner
AMPs	120V / 12AMPs
NPT	3/4"
Oven Weight	5,300 lbs.
Crated Weight	5,700 lbs.
Crated W x D x H	85" x 108" x 87"
Pizza Capacity 8"	14
Pizza Capacity 10"	12
Pizza Capacity 12"	10
Pizza Capacity 16"	6-7

*Oven sizes refer to dome interior size. All ovens Freight Class 85 and ETL, and VPN approved. Oven must be shipped LTL.

Marra Forni Rotator RT 150

Rotator RT 150 (MF.RT150G) Gas Model, also available as "MF.RT150W" Wood-Fired.



*Tile work shown in photo is custom and is not included in standard tile options.



This oven is available in standard tile finishes of Red, White, Brown, Blue or Black at no additional cost. There is a \$4 per square foot net deduction per oven if you choose to use custom tile.

Features

- Refractory brick with 4" of layered insulation in the dome, 8" in the deck.
- Fire-rated tile exterior over clay dome
- 59.06 inch / 150 cm - diameter deck
- Oven mouth measures 24" x 9.5"
- 8" diameter S/S flue collar
- Turbo Burner
- 14" landing at the opening
- 2 year deck warranty
- Mechanical Thermostat (0 - 1000°F)

Gas Requirements

- 120V / Single Phase/ 12AMPs
- 84,000 BTUs per burner
- 1 gas connection 3/4" NPT NPT per burner
- The oven is vented through an 6" round flue collar interconnected to an exhaust system integral with the oven hearth. The Neapolitan gas-fired oven can be direct vented via a grease rated chimney or with a listed type 1 exhaust hood (or equivalent).

Quick Specs	Rotator 150
Height	81.75"
Width	84.32"
Depth	81.99"
Cooking Surface	15.5 sq. ft.
BTUs (NAT)	84,000
AMPs	120V / 12AMPs
NPT	3/4"
Oven Weight	7,000 lbs.
Crated Weight	7,400 lbs.
Crated W x D x H	85" x 108" x 87"
Pizza Capacity 8"	16
Pizza Capacity 10"	14
Pizza Capacity 12"	12
Pizza Capacity 16"	8

*Oven sizes refer to dome interior size. All ovens Freight Class 85 and ETL, and VPN approved. Oven must be shipped LTL.

Marra Forni Rotator RT 150WG

Rotator RT 150WG (MF.RT 110WG) Wood-Gas Fired Model



*Tile work shown in photo is custom and is not included in standard tile options.



This oven is available in standard tile finishes of Red, White, Brown, Blue or Black at no additional cost. There is a \$4 per square foot net deduction per oven if you choose to use custom tile.

Features

- Refractory brick with 4" of layered insulation in the dome, 8" in the deck.
- Fire-rated tile exterior over clay dome
- 51.18 inch / 150 cm - diameter deck
- Oven mouth measures 24" x 9.5"
- 8" diameter S/S flue collar
- Turbo Burner
- 14" landing at the opening
- 2 year deck warranty
- Mechanical Thermostat (0 - 1000°F)

Gas Requirements

- 120V / Single Phase/ 12AMPs
- 84,000 BTUs per burner
- 1 gas connection 3/4" NPT NPT per burner
- The oven is vented through an 6" round flue collar interconnected to an exhaust system integral with the oven hearth. The Neapolitan gas-fired oven can be direct vented via a grease rated chimney or with a listed type 1 exhaust hood (or equivalent).

Quick Specs	Rotator WG150
Height	82.25"
Width	85.87"
Depth	86"
Cooking Surface	15.5 sq. ft.
BTUs (NAT)	84,000
AMPs	120V / 12AMPs
NPT	3/4"
Oven Weight	7,000 lbs.
Crated Weight	7,400 lbs.
Crated W x D x H	87" x 108" x 87"
Pizza Capacity 8"	16
Pizza Capacity 10"	14
Pizza Capacity 12"	12
Pizza Capacity 16"	8

*Oven sizes refer to dome interior size. All ovens Freight Class 85 and ETL, and VPN approved. Oven must be shipped LTL.

Marra Forni Traditional 90, 110, 130, 140, 150

Gas Models: between 8" W.C to 10"W.C



Standard Tile Color Options



Standard Facade Options
- Stainless Steel or Black

Wood Burning Models
Traditional 90 (TR90W*)
Traditional 110 (TR110W*)
Traditional 130 (TR130W*)
Traditional 140 (TR140W*)
Traditional 150 (TR150W*)

Gas Converted Models
Traditional 90 (TR90G*)
Traditional 110 (TR110G*)
Traditional 130 (TR130G*)
Traditional 140 (TR140G*)
Traditional 150 (TR150G*)

For an additional cost, upgrade to stainless steel or apply black powder coating to the metal facade.

Quick Specs	Traditional 90*	Traditional 110*	Traditional 130*	Traditional 140*	Traditional 150*
Height	66.51"	67.31"	69.56"	69.56"	70.81"
Width	48.68"	56.56"	4.43"	68.37"	72.31"
Depth	54.13"	62.01"	69.88"	73.82	77.76"
Cooking Surface	6.56 sq. ft..	9.86 sq. ft..	13.84 sq. ft..	16.36 sq. ft..	18.96 sq. ft..
BTUs (NAT)	84,000	84,000	84,000	84,000	84,000
AMPs	120V / 12AMPs	120V / 12AMPs	120V / 12AMPs	120V / 12AMPs	120V / 12AMPs
NPT	3/4"	3/4"	3/4"	3/4"	3/4"
Oven Weight	1,850 lbs	3,100 lbs.	4,300 lbs.	4,400 lbs.	4,700 lbs.
Crated Weight	2,150 lbs	3,400 lbs	4,700 lbs	4,800 lbs.	5,100 lbs.
Crate W x D x H	73" x 63" x 86	83" x 73" x 86"	96" x 83" x 84"	85" x 108" x 87"	85" x 108" x 87"
Pizza Capacity 8"	4 - 5	7-8	8-9	10-12	14 - 16
Pizza Capacity 10"	3 - 4	6-7	7-8	9-11	12 - 14
Pizza Capacity 12"	2 - 3	4-6	6-5	8-10	10 - 12

*Denotes Internal Model Number of the Oven. Oven sizes refer to dome interior size. All ovens Freight Class 85.

Marra Forni Traditional 90

Traditional 90 (MF.TR90G) Gas Model, also available as "MF.TR90W" Wood-Fired.



*Tile work shown in photo is custom and is not included in standard tile options.



This oven is available in standard tile finishes of Red, White, Brown, Blue or Black at no additional cost. There is a \$4 per square foot net deduction per oven if you choose to use custom tile.

Features

- Refractory brick with 4" of layered insulation in the dome, 8" in the deck.
- Fire-rated tile exterior over clay dome
- 35.43 inch / 90 cm - diameter deck
- Oven mouth measures 18" x 9"
- 6" diameter S/S flue collar
- Turbo Burner
- 12" landing at the opening
- 3 year deck warranty
- Mechanical Thermostat (0 - 1000°F)

Gas Requirements

- 120V / Single Phase/ 12AMPs
- 84,000 BTUs per burner
- 1 gas connection 3/4" NPT NPT per burner
- The oven is vented through an 8" round flue collar interconnected to an exhaust system integral with the oven hearth. The Neapolitan gas-fired oven can be direct vented via a grease rated chimney or with a listed type 1 exhaust hood (or equivalent).

Quick Specs	Traditional 90
Height	66.51"
Width	48.68"
Depth	54.13"
Cooking Surface	6.56 sq. ft.
BTUs (NAT)	84,000
AMPS	120V / 12AMPs
NPT	3/4"
Oven Weight	1,850 lbs.
Crated Weight	2,150 lbs.
Crated W x D x H	73" x 63 x 86"
Pizza Capacity 8"	4-5
Pizza Capacity 10"	3-4
Pizza Capacity 12"	2-3
Pizza Capacity 16"	1-2

*Oven sizes refer to dome interior size. All ovens Freight Class 85 and ETL, and VPN approved. Oven must be shipped LTL.

Marra Forni Traditional 110

Traditional 110 (MF.TR110G) Gas Model, also available as "MF.TR110W" Wood-Fired.



*Tile work shown in photo is custom and is not included in standard tile options.



This oven is available in standard tile finishes of Red, White, Brown, Blue or Black at no additional cost. There is a \$4 per square foot net deduction per oven if you choose to use custom tile.

Features

- Refractory brick with 4" of layered insulation in the dome, 8" in the deck.
- Fire-rated tile exterior over clay dome
- 43.31 inch / 110 cm - diameter deck
- Oven mouth measures 18 x 9"
- 8" diameter S/S flue collar
- Turbo Burner
- 12" landing at the opening
- 3 year deck warranty
- Mechanical Thermostat (0 - 1000°F)

Gas Requirements

- 120V / Single Phase/ 12AMPs
- 84,000 BTUs per burner
- 1 gas connection 3/4" NPT NPT per burner
- The oven is vented through an 8" round flue collar interconnected to an exhaust system integral with the oven hearth. The Neapolitan gas-fired oven can be direct vented via a grease rated chimney or with a listed type 1 exhaust hood (or equivalent).

Quick Specs	Traditional 110
Height	67.31"
Width	56.56"
Depth	62.01"
Cooking Surface	9.86 sq. ft.
BTUs (NAT)	84,000
AMPs	120V / 12AMPs
NPT	3/4"
Oven Weight	3,100 lbs.
Crated Weight	3,400 lbs.
Crated W x D x H	83" x 73" x 86"
Pizza Capacity 8"	7-8
Pizza Capacity 10"	6-7
Pizza Capacity 12"	4-6
Pizza Capacity 16"	3-4

*Oven sizes refer to dome interior size. All ovens Freight Class 85 and ETL, and VPN approved. Oven must be shipped LTL.

Marra Forni Traditional 130

Traditional 130 (MF.TR130G) Gas Model, also available as "MF.TR130W" Wood-Fired.



*Tile work shown in photo is custom and is not included in standard tile options.



This oven is available in standard tile finishes of Red, White, Brown, Blue or Black at no additional cost. There is a \$4 per square foot net deduction per oven if you choose to use custom tile.

Features

- Refractory brick with 4" of layered insulation in the dome, 8" in the deck.
- Fire-rated tile exterior over clay dome
- 51.18 inch / 130 cm - diameter deck
- Oven mouth measures 24" x 9.5"
- 8" diameter S/S flue collar
- Turbo Burner
- 12" landing at the opening
- 3 year deck warranty
- Mechanical Thermostat (0 - 1000°F)

Gas Requirements

- 120V / Single Phase/ 12AMPs
- 84,000 BTUs per burner
- 1 gas connection 3/4" NPT NPT per burner
- The oven is vented through an 8" round flue collar interconnected to an exhaust system integral with the oven hearth. The Neapolitan gas-fired oven can be direct vented via a grease rated chimney or with a listed type 1 exhaust hood (or equivalent).

Quick Specs	Traditional 130
Height	69.56"
Width	4,43"
Depth	69.88"
Cooking Surface	13.84 sq. ft.
BTUs (NAT)	84,000
AMPS	120V / 12AMPs
NPT	3/4"
Oven Weight	4,300 lbs.
Crated Weight	4,700 lbs.
Crated W x D x H	96" x 83" x 84"
Pizza Capacity 8"	16-18
Pizza Capacity 10"	14-16
Pizza Capacity 12"	8-10
Pizza Capacity 16"	4-6

*Oven sizes refer to dome interior size. All ovens Freight Class 85 and ETL, and VPN approved. Oven must be shipped LTL.

Marra Forni Traditional 140

Traditional 140 (MF.TR140G) Gas Model, also available as "MF.TR140W" Wood-Fired.



*Tile work shown in photo is custom and is not included in standard tile options.



This oven is available in standard tile finishes of Red, White, Brown, Blue or Black at no additional cost. There is a \$4 per square foot net deduction per oven if you choose to use custom tile.

Features

- Refractory brick with 4" of layered insulation in the dome, 8" in the deck.
- Fire-rated tile exterior over clay dome
- 55.12 inch / 140 cm - diameter deck
- Oven mouth measures 24" x 9.5"
- 8" diameter S/S flue collar
- Turbo Burner
- 12" landing at the opening
- 3 year deck warranty
- Mechanical Thermostat (0 - 1000°F)

Gas Requirements

- 120V / Single Phase/ 12AMPs
- 84,000 BTUs per burner
- 1 gas connection 3/4" NPT NPT per burner
- The oven is vented through an 8" round flue collar interconnected to an exhaust system integral with the oven hearth. The Neapolitan gas-fired oven can be direct vented via a grease rated chimney or with a listed type 1 exhaust hood (or equivalent).

Quick Specs	Traditional 140
Height	69.56"
Width	68.37"
Depth	73.82
Cooking Surface	16.36 sq. ft.
BTUs (NAT)	84,000
AMPs	120V / 12AMPs
NPT	3/4"
Oven Weight	4,400 lbs.
Crated Weight	4,800 lbs.
Crated W x D x H	85" x 108" x 87"
Pizza Capacity 8"	10-12
Pizza Capacity 10"	9-11
Pizza Capacity 12"	8-10
Pizza Capacity 16"	6-7

*Oven sizes refer to dome interior size. All ovens Freight Class 85 and ETL, and VPN approved. Oven must be shipped LTL.

Marra Forni Traditional 150

Traditional 150 (MF.TR150G) Gas Model, also available as "MF.TR150W" Wood-Fired.



*Tile work shown in photo is custom and is not included in standard tile options.



This oven is available in standard tile finishes of Red, White, Brown, Blue or Black at no additional cost. There is a \$4 per square foot net deduction per oven if you choose to use custom tile.

Features

- Refractory brick with 4" of layered insulation in the dome, 8" in the deck.
- Fire-rated tile exterior over clay dome
- 59.06 inch / 150 cm - diameter deck
- Oven mouth measures 26" x 9.5"
- 8" diameter S/S flue collar
- Turbo Burner
- 12" landing at the opening
- 3 year deck warranty
- Mechanical Thermostat (0 - 1000°F)

Gas Requirements

- 120V / Single Phase/ 12AMPs
- 84,000 BTUs per burner
- 1 gas connection 3/4" NPT NPT per burner
- The oven is vented through an 8" round flue collar interconnected to an exhaust system integral with the oven hearth. The Neapolitan gas-fired oven can be direct vented via a grease rated chimney or with a listed type 1 exhaust hood (or equivalent).

Quick Specs	Traditional 150
Height	70.81"
Width	72.31"
Depth	77.76"
Cooking Surface	18.96 sq. ft.
BTUs (NAT)	84,000
AMPS	120V / 12AMPs
NPT	3/4"
Oven Weight	4,700 lbs.
Crated Weight	5,100 lbs.
Crated W x D x H	85" x 108" x 87"
Pizza Capacity 8"	14-16
Pizza Capacity 10"	12-14
Pizza Capacity 12"	10-12
Pizza Capacity 16"	7-8

*Oven sizes refer to dome interior size. All ovens Freight Class 85 and ETL, and VPN approved. Oven must be shipped LTL.

Marra Forni Due Bocche 165, 180

Gas Models: between 8" W.C to 10"W.C

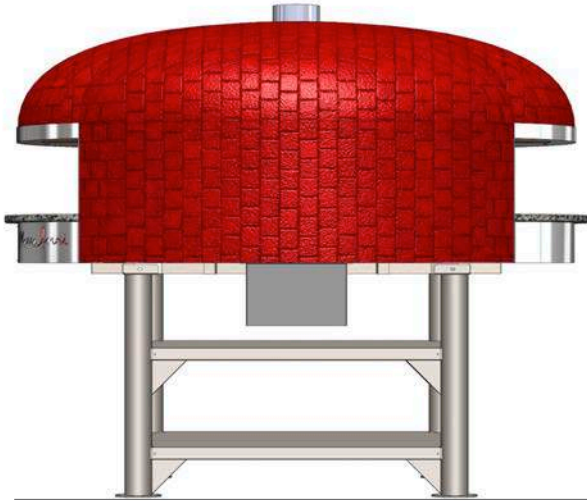

Standard Tile Color Options



Standard Facade Options
- Stainless Steel or Black

Wood Burning Models
Due Bocche 165
Due Bocche 180

Gas Converted Models
Due Bocche Gas 165
Due Bocche Gas 180

For an additional cost, upgrade to stainless steel or apply black powder coating to the metal facade.

Quick Specs	Due Bocche 165*	Due Bocche 180*
Height	81"	81.75"
Width	78.21"	84.12"
Depth	93.21"	99.12"
Cooking Surface	22.89 sq. ft..	27.31 sq. ft.
BTUs (NAT)	84,000	84,000
AMPs	120V / 12AMPs	120V / 12AMPs
NPT	3/4"	3/4"
Oven Weight	6,300 lbs	8,500 lbs.
Crated Weight	6,700 lbs	8,800 lbs
Crate W x D x H	108" x 95" x 86"	85" x 108" x 101"
Pizza Capacity 8"	18-20	33
Pizza Capacity 10"	16-18	25
Pizza Capacity 12"	14-16	20
Pizza Capacity 16"	10-12	11

*Denotes Internal Model Number of the Oven. Oven sizes refer to dome interior size. All ovens Freight Class 85.

Marra Forni Due Bocche 165

Due Bocche 165 (NP.165G-DB) Gas Model, also available as "NP.165W-DB" Wood-Fired.

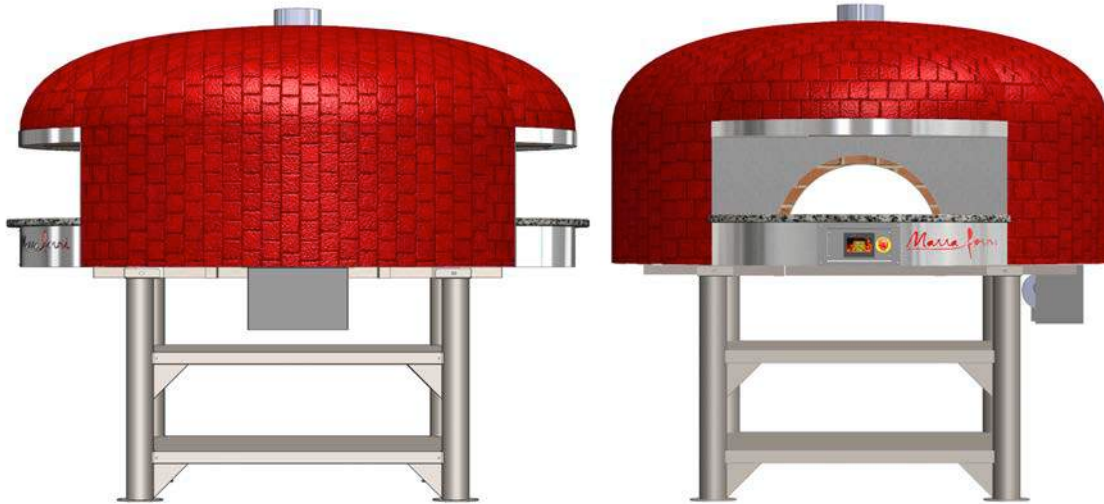

*Tile work shown in photo is custom and is not included in standard tile options.



This oven is available in standard tile finishes of Red, White, Brown, Blue or Black at no additional cost. There is a \$4 per square foot net deduction per oven if you choose to use custom tile.

Features

- Refractory brick with 4" of layered insulation in the dome, 8" in the deck.
- Fire-rated tile exterior over clay dome
- 51.18 inch / 130 cm - diameter deck
- Oven mouth measures 24" x 9.5"
- 8" diameter S/S flue collar
- Turbo Burner
- 12" landing at the opening
- 3 year deck warranty
- Mechanical Thermostat (0 - 1000°F)

Gas Requirements

- 120V / Single Phase/ 12AMPs
- 84,000 BTUs per burner
- 1 gas connection 3/4" NPT NPT per burner
- The oven is vented through an 8" round flue collar interconnected to an exhaust system integral with the oven hearth. The Neapolitan gas-fired oven can be direct vented via a grease rated chimney or with a listed type 1 exhaust hood (or equivalent).

Quick Specs	Due Bocche 165
Height	81"
Width	78.21"
Depth	93.21"
Cooking Surface	22.89 sq. ft..
BTUs (NAT)	84,000
AMPs	120V / 12AMPs
NPT	3/4"
Oven Weight	6,300 lbs
Crated Weight	6,700 lbs
Crated W x D x H	108" x 95" x 86"
Pizza Capacity 8"	18-20
Pizza Capacity 10"	16-18
Pizza Capacity 12"	14-16
Pizza Capacity 16"	10-12

*Oven sizes refer to dome interior size. All ovens Freight Class 85 and ETL, and VPN approved. Oven must be shipped LTL.

Marra Forni Due Bocche 180

Due Bocche 180 (NP.180G-DB) Gas Model, also available as "NP.180W-DB" Wood-Fired.

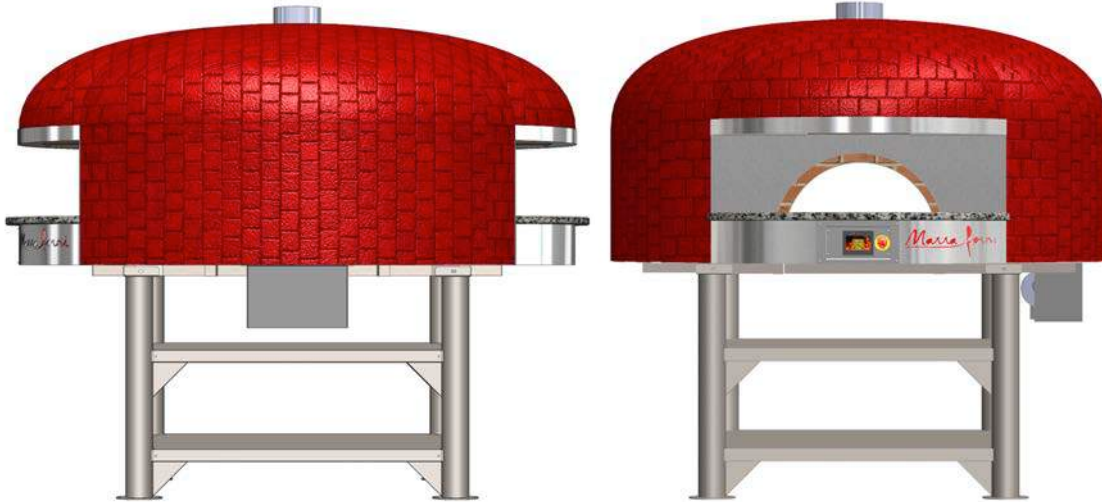

*Tile work shown in photo is custom and is not included in standard tile options.



This oven is available in standard tile finishes of Red, White, Brown, Blue or Black at no additional cost. There is a \$4 per square foot net deduction per oven if you choose to use custom tile.

Features

- Refractory brick with 4" of layered insulation in the dome, 8" in the deck.
- Fire-rated tile exterior over clay dome
- 55.12 inch / 140 cm - diameter deck
- Oven mouth measures 24" x 9.5"
- 8" diameter S/S flue collar
- Turbo Burner
- 12" landing at the opening
- 3 year deck warranty
- Mechanical Thermostat (0 - 1000°F)

Gas Requirements

- 120V / Single Phase/ 12AMPs
- 84,000 BTUs per burner
- 1 gas connection 3/4" NPT NPT per burner
- The oven is vented through an 8" round flue collar interconnected to an exhaust system integral with the oven hearth. The Neapolitan gas-fired oven can be direct vented via a grease rated chimney or with a listed type 1 exhaust hood (or equivalent).

Quick Specs	Due Bocche 180
Height	81"
Width	83"
Depth	99"
Cooking Surface	27.5 sq. ft.
BTUs (NAT)	84,000
AMPs	120V / 12AMPs
NPT	3/4"
Oven Weight	8,500 lbs.
Crated Weight	8,800 lbs.
Crated W x D x H	85" x 108" x 101"
Pizza Capacity 8"	33
Pizza Capacity 10"	25
Pizza Capacity 12"	20
Pizza Capacity 16"	11

*Oven sizes refer to dome interior size. All ovens Freight Class 85 and ETL, and VPN approved. Oven must be shipped LTL.

Marra Forni Capri

Gas / Wood-Fired



*Tile work shown in photo is custom and is not included in standard tile options.



This oven is available in standard tile finishes of Red, White, Brown, Blue or Black at no additional cost. There is a \$4 per square foot net deduction per oven if you choose to use custom tile.

Features

- Dome Terra Cotta Finish
- Turbo Burner
- Brick Deck
- Integral Exhaust System
- Stainless Steel Flue Collar/Adapter
- Steel Stand
- Powder Coating
- 2 Year Deck and Dome Warranty

Gas Requirements

- Gas connections 3/4" NPT per burner,
- Quickdisconnect gas hose must be used
- 84,000 BTU's per burner

Electrical Requirements

- 120V/ Single Phase / 12Amps
- 9 ft. power cable integrated.

Quick Specs	Capri
Height	59.5"
Width	37.5"
Depth	39.1"
Cooking Surface	13.84 sq. ft.
BTUs (NAT)	84,000
AMPs	120V / 12AMPs
NPT	3/4"
Oven Weight	1,500 lbs.
Crated Weight	1,850 lbs.
Crated W x D x H	56" x 63" x 82"
Pizza Capacity 12"	2-3

*Oven sizes refer to dome interior size. All ovens Freight Class 85 and ETL, and VPN approved. Oven must be shipped LTL.

Marra Forni Refrigeration

- Features
- Stainless Steel Interior/Exterior
 - Granite Work Surface
 - Casters Standard
 - Digital Controller
 - Self-Closing Doors
 - 4 Plastic Dough Trays per Door
 - 2 3/8" Polyurethane Insulation
 - Self-Contained Refrigeration
 - Optional Granite Backsplash and Sides



GPZ 166 Models
GPZ 166 (No Condiment Rail)
GPZ 166A (With Condiment Rail)
GAC 166 (Rail Only)

GPZ 225 Models
GPZ 225 (No Condiment Rail)
GPZ 225A (With Condiment Rail)
GAC 225 (Rail Only)

Two Door

Model #	Classification	Refrigerator	Volts/Hz	Phase	Full Load (Amps)	Temp (F)	Dimensions (inches)			Packing Dimensions (inches)		
GPZ - 88	Refrigerator	R404A	116/60	1	6.2	34F - 55 F	Width 65.5	Depth 31.3	Height 31.25	Width 67	Depth 33	Height 44.75
HP	Doors	Shelves	Guides	Weight (lbs)	Cubic (ft.)	Notes:						
1/5	2	n/a	12	397	12	- Specifications are subject to change without notice. - Chart dimensions are rounded up to the nearest 1/8". - Two year warranty on all parts and labor, and three year warranty on the compressor (USA only).						

Three Door

Model #	Classification	Refrigerator	Volts/Hz	Phase	Full Load (Amps)	Temp (F)	Dimensions (inches)			Packing Dimensions (inches)		
GPZ - 225	Refrigerator	R404A	115/60	1	6.6	34F - 55 F	Width 87.75	Depth 31.5	Height 31.25	Width 89.5	Depth 33	Height 44.25
HP	Doors	Shelves	Guides	Weight (lbs)	Cubic (ft.)	Notes:						
1	3	n/a	18	661	20	- Specifications are subject to change without notice. - Chart dimensions are rounded up to the nearest 1/8". - Two year warranty on all parts and labor, and three year warranty on the compressor (USA only).						

*All prep tables and condiment rails- Freight Class 92.5.

Condiment Rail Specs

Both Models Feature
 Stainless Steel Interior/Exterior (AISI 304)
 2 inch Polyurethane Insulation
 Self-Contained Refrigeration
 Automatic Evaporation of Condensation
 Digital Controller



Two Door

Model #	Classification	Refrigerator	Volts/Hz	Phase	Full Load (Amps)	Temp (F)	Dimensions (inches)			Packing Dimensions (inches)		
GAC 166	Refrigerator	R404A	115/60	1	2	34 to 55	Width 65.5	Depth 15	Height 16.5	Width 67	Depth 17	Height 15
HP	Doors	Shelves	Guides	Weight (lbs)	Cubic (ft.)	Notes: - Specifications are subject to change without notice. - Chart dimensions are rounded up to the nearest 1/8". - Two year warranty on all parts and labor, and three year warranty on the compressor (USA only).						
1/5	n/a	n/a	n/a	132	1.93							

*Includes glass sneeze guard height



Three Door

Model #	Classification	Refrigerator	Volts/Hz	Phase	Full Load (Amps)	Temp (F)	Dimensions (inches)			Packing Dimensions (inches)		
GAC 166	Refrigerator	R404A	115/60	1	2	34 to 55	Width 88	Depth 16	Height 18.5	Width 90	Depth 17	Height 20.5
HP	Doors	Shelves	Guides	Weight (lbs)	Cubic (ft.)	Notes: - Specifications are subject to change without notice. - Chart dimensions are rounded up to the nearest 1/8". - Two year warranty on all parts and labor, and three year warranty on the compressor (USA only).						
1/5	n/a	n/a	n/a	145	2.85							

*Includes glass sneeze guard height

Marra Forni Spiral Mixers

Marra Forni spiral mixers are the ideal machine for restaurants, confectionaries, bakeries and domestic use. Take advantage of our range of sizes, from 5 to 60 kg. Although forked mixers are superior for high-hydration doughs, spiral mixers allow you to mix wider varieties of dough. Both mixers produce better gluten development due to a lack of heat, but spiral mixers cut your mixing time in half.

QUICK SPECS

Marra Spiral Mixers						A x C x B*
Model	Knead Capacity	Flour Cap.	Bowl Cap.	Weight (kg/lb.)	Motor Pwr.	Dimensions(in.)
IM5M	5 kg / 11 lbs.	7 lbs.	7 qt.	33 / 73	.5 hp	21 x 10 x 21
IM8M	8 kg / 18 lbs.	11 lbs.	11 qt.	36 / 79	.5 hp	22 x 11 x 22
IM12M	12 kg / 27 lbs.	18 lbs.	16 qt.	60 / 132	1.2 hp	27 x 14 x 27
IM12D	12 kg / 27 lbs.	18 lbs.	16 qt.	60 / 132	.8 / 1.1 hp	27 x 14 x 27
IM18M	18 kg / 40 lbs.	27 lbs.	21 qt.	65 / 143	1.2 hp	27 x 15 x 27
IM18D	18 kg / 40 lbs.	27 lbs.	21 qt.	65 / 143	.8 / 1.1 hp	27 x 15 x 27
IM25M	25 kg / 55 lbs.	37 lbs.	35 qt.	95 / 209	1.5 hp	30 x 17 x 30
IM25D	25 kg / 55 lbs.	37 lbs.	35 qt.	95 / 209	1.3 / 1.4 hp	30 x 17 x 30
IM38M	38 kg / 84 lbs.	55 lbs.	42 qt.	105 / 232	2 hp	32 x 19 x 30
IM38D	38 kg / 84 lbs.	55 lbs.	42 qt.	105 / 232	2 / 3 hp	32 x 19 x 30
IM44M	44 kg / 97 lbs.	66 lbs.	53 qt.	110 / 243	2 hp	33 x 21 x 30
IM44D	44 kg / 97 lbs.	66 lbs.	53 qt.	110 / 243	2 / 3 hp	33 x 21 x 30
IM60M	60 kg / 132 lbs.	88 lbs.	80 qt.	250 / 551	3.5 hp	40 x 23 x 40
IM60D	60 kg / 132 lbs.	88 lbs.	80 qt.	250 / 551	3.5 / 4.6 hp	40 x 23 x 40

*Dimensions rounded to the nearest inch.

Red Outline in illustration indicates optional removable bowl and lid, available on models 12-44.

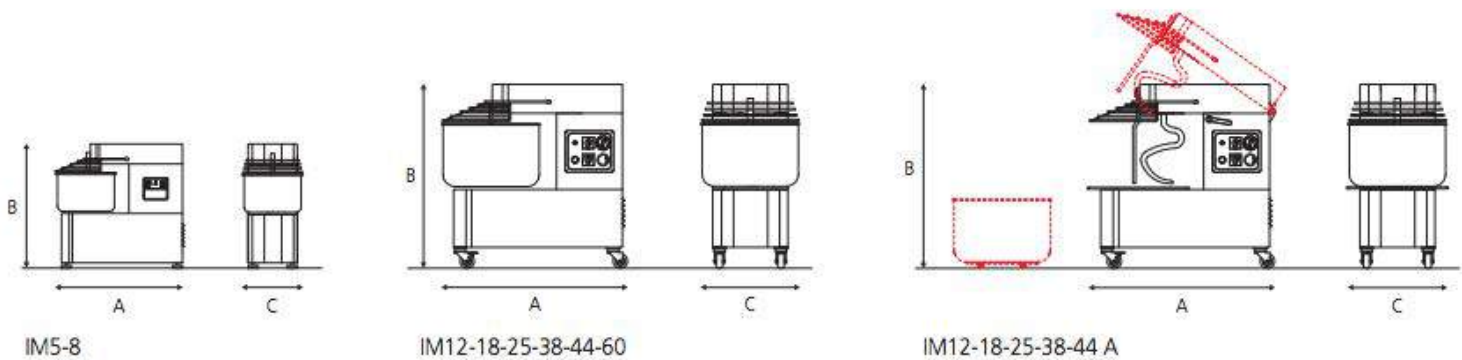

TECHNICAL SPECIFICATIONS

- Models from 12 to 44 kg are supplied with wheels and brakes.
- Stainless steel frame, bowl, fork, protection cover, and tool-holder shaft.
- Standard timer from 12 to 60 kg models.
- Rotating parts are assembled on ball bearings.
- Chain drive system uses a geared motor.
- Electric system and safety devices meet European regulations.



All mixers- Freight Class 85. One year labor / parts warranty. All Mono models are 220V/1ph, all Dual models are 220V/3ph.

Marra Forni Mixers

Marra Forni mixers are very well-suited for making soft doughs. The shape of the tool and its bowl allows the dough to become oxygenated quickly without warming up. The forked mixer yields a final product superior to that offered by other mixers because it prevents heating of the dough. Let your oven cook your dough, not the mixer!

QUICK SPECS

Model	Knead Capacity	Flour Capacity	Bowl Capacity	Weight (kg/lb.)	Motor Power
FC25M	25 kg / 55 lbs.	35 lbs.	32 qt.	140 / 309	1.5 hp
FC25D	25 kg / 55 lbs.	35 lbs.	32 qt.	140 / 309	1 / 1.5 hp
FC35M	35 kg / 77 lbs.	50 lbs.	42 qt.	145 / 320	1.5 hp
FC35D	35 kg / 77 lbs.	50 lbs.	42 qt.	145 / 320	1 / 1.5 hp
FC60D	60 kg / 132 lbs.	88 lbs.	74 qt.	240 / 530	1.2 / 1.8 hp
FC80D	80 kg / 176 lbs.	116 lbs.	98 qt.	290 / 640	1.5 / 2 hp

All mixers- Freight Class 85. One year labor and parts warranty.
All Mono models are 220V/1ph, all Dual models are 220V/3ph.

FC25 M/D - 30qt. bowl

0-90 dough balls per 17-20 min. mix

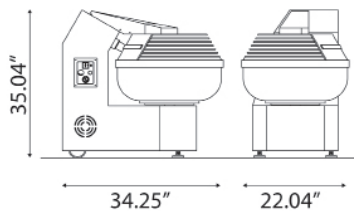

FC35 M/D - 40qt. bowl

90-110 dough balls per 17-20 min. mix

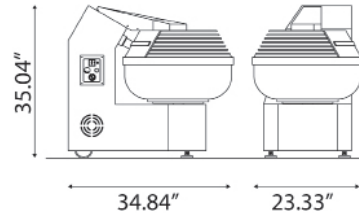

FC60D - 70qt. bowl

110-200 dough balls per 17-20 min. mix

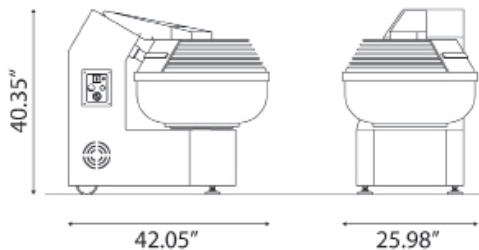

FC80D - 95qt. bowl

200-280 dough balls per 17-20 min. mix

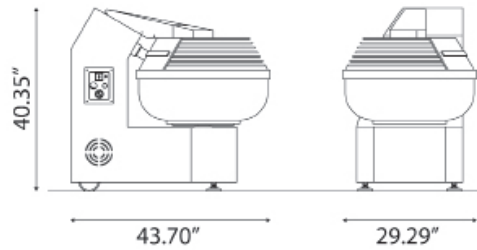

TECHNICAL SPECIFICATIONS

- Stainless steel frame, bowl, fork and tool-holder shaft.
- Bowl is covered in transparent poly-carbonate for 25 and 35 models. Grill is stainless steel for 60 and 80 models.
- Chain drive system is made using trapezoidal belts and independently geared speed reducers for the bowl and fork.
- Rotating parts are assembled on ball bearings.
- Models 35, below require 15 amp; 60 and 80 require 20 amp.
- Electric system and safety devices meet European regulations.



Marra Forni Slicers

100% Italian made flywheel slicers from Marra Forni combine precision slicing with the classic visual appeal of a hand operated flywheel. Cast in aluminum and steel, the body of the slicer facilitates fast and easy cleanup.

This unit is fully operated by hand, leaving you free to display your slicer anywhere to entice customers. The blade sharpener is built-in and equipped with a protection ring which meets standards. Customize your slicer with RAL colors and unique flywheel styles.

Hand-Operated Flywheel Slicers

Slicer Quick Specs* - Units in Inches, Unless Otherwise Noted				
	Volano 300	Volano 350	Volano 370	Pedestal
Blade (mm, in)	300 mm, 11.81 in	350 mm, 13.78 in	370 mm, 14.57 in	---
Cutting Thickness	0-2 in.	0-2.5 in.	0-2.5 in.	---
Cutting Capacity	9.1 x 7.5	10.6 x 9.4	10.6 x 9.8	---
Height	29.1	31.5	29.9	31.3
Width	23.6	28	28	28.7
Length	28.3	34.3	35.4	28.7
Weight (kg / lb.)	45.5 / 101	81 / 179	81 / 179	65 / 144
Dist. Btw. Feet	13.4 x 15.7	15.7 x 23.6	10.7 x 23.8	---

*All inch measurements are rounded from millimeters to the nearest tenth. Flywheel shown in product photo is optional. A customizing surcharge will be applied for Flywheel and RAL color upgrades. All slicers are Freight Class 85.



*Pedestal is an added upgrade. Shown here for illustrative purposes only.

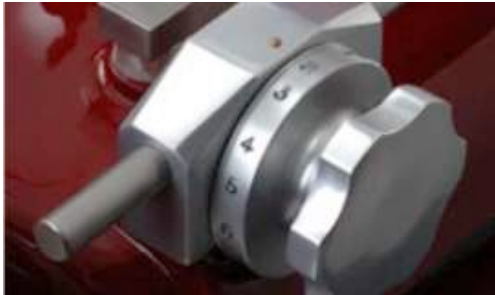

Standard Flywheel Style



Fillettatura Flywheel Option Shown.



Options:

- Cast Iron Stand
- Different Flywheel styles
- RAL color customizing

Marra Forni Flue Pipe and Fan

Marra Forni offers state of the art flue pipes for all of our ovens. DWKL is the designation model number for Marra Forni's Double Wall conical Grease Duct and Chimney system. The -LT variation has a different inner thickness. For the purpose of these installation instructions, both DWKL and the DWKL-Lt will be treated together. Differences in UL listing, installation, and weights will be shown where needed.

Specs

- UL-1978 Standard, Grease Duct for liquid tight joints and 2000°F for 30 minutes
- ULC-S662, (Canadian) Standard for Factory-Built Grease
- UL-2561 Standard, 1400F Chimney Listing/ ULC/ORDC959 Industrial Type 760°C Chimney
- UL-103 Standard, Building Heating Appliance Chimney Listing
- ULC/ORD-C959 Industrial Type 540°C Chimney
- UL-103 Standard, Additional Positive Pressure Listing up to 90" W.C.
- UL-103 Standard, Additional Type HT Listing, 1000°F and 2100°F for 10 minutes
- 0.035" Thick 444 stainless steel inner liner, 1.5" ceramic fiber blanket compressed to 1.25", and 430 stainless steel outer jacket with all stainless steel supports and accessories.

Benefits

- Powered exhaust on Rotator ovens
- Grade 444 stainless steel
- High temperature ducting
- Easy to Install
- Easy to Clean
- 25 Year Warranty



*Contact sales rep for more information regarding flue pipes. inquires@marraforni.com

Why Marra Forni....

1. Our Italian-style prep tables are drafted by designers who understand the needs of Neapolitan pizza makers and have taken care to organize the space to meet those specifications.
2. All of our ovens are produced HERE in the United States using key component materials from Italy. They are not shipped in loose pieces but as a whole unit.
3. Our decks do not crack. Many brick oven owners know that at some point their deck will crack and require costly repairs or replacement (customers will not be pleased to bite down on a pebble of cement during their meal). Marra Forni uses refractory bricks that allow for expansion and contraction during the frequent temperature shifts which happen thousands of times over the life of the oven.
4. Our ovens are some of the lightest weight brick ovens in the industry, yet do not sacrifice quality. Many people never take weight load into consideration, but a lighter oven allows for greater flexibility when looking into leasing a new space. Our wide range of sizes for all of our products accommodates any volume of pizza making.
5. Our products are preferred by professionals as well as teachers of the industry, including but not limited to Verace Pizza Neapolitana, all of the American Pizza Team, Whole Foods, and the Tony Gemignani School of Pizza.
6. Marra Forni forked dough mixers “fold” the dough rather than mixing it. This prevents the dough from becoming heated from the friction of being mixed, guaranteeing you a “cleaner” dough and a fresher-tasting end result. Let your oven cook your dough, not the mixer!
7. Our company is based in the United States and we stock all of our units, which means a faster ship time for our customers.
8. We offer our clients the option to fully customize the outside of their oven with an endless variety of tile colors and textures. We can even apply patterns, or the name of your restaurant on the front of your oven. With Marra Forni, your oven is more than just an appliance, it is a work of art.
9. Unprecedented technological advances enable our curing cases to boast “One Touch” salami making. Our Stagionello curing cases are unmatched for their hygiene, speed and authentic pre-programmed recipes that allow you to broadly expand your culinary offerings.
10. Marra Forni products are designed with a pizzaiolo’s needs in mind, yet can accommodate any style of cuisine. Many of our clients base entire menus around their Marra Forni oven. Schedule a demo at one of our test kitchens, and see for yourself!

UL, CSA, ETL and CE: What is the difference? These are all stamps of approval. Marra Forni products with these logos meet rigorous standards for electrical safety and electromagnetic emissions. The acronyms are spelled out below.

UL: Underwriters Laboratories, Inc.

CSA: Canadian Standards Association

ETL: Originally a mark of ETL Testing Laboratories, now a mark of Intertek Testing Services.

CE: Conformance European

Underwriter's Laboratories Inc. is an independent non-profit organization that writes and tests products for safety and certifies them. UL has developed more than 800 standards for safety, and millions of products and their components are tested to UL's safety standards. UL's web site is <http://www.ul.com>. Information about UL standards can be found at <http://ulstandardsinonet.ul.com>. If a Marra Forni product is UL listed, you know it has passed UL's stringent tests for electrical safety.

The Canadian Standards Association (CSA) is a non-profit association serving business, industry, government and consumers in Canada and the global marketplace. Among many other activities, CSA develops standards that enhance public safety. A Nationally Recognized Testing Laboratory, CSA is very familiar with U.S. requirements. According to OSHA regulations, the CSA-US mark qualifies as an alternative to the UL mark. The ETL listed mark is an alternative to the CSA and UL marks.

ETL Testing Laboratories has been conducting electrical performance and reliability tests since 1896. Intertek Testing Services (ITS) acquired ETL from Inchscape in 1996. ITS is recognized by OSHA as a Nationally Recognized Testing Laboratory (NRTL), just as UL, CSA, and several other independent organizations are. ITS tests products according to nearly 200 safety and performance standards. The ETL listed mark and C-ETL listed mark are accepted throughout the U.S. and Canada when denoting compliance with nationally recognized standards such as ANSI, IEC, UL and CSA. This certification mark indicates that the product has been tested to and has met the minimum requirements of a widely recognized (consensus) U.S. product safety standard, that the manufacturing site has been audited, and that the applicant has agreed to a program of periodic factory follow-up inspections to verify continued conformance. If the mark includes a small U.S. and/or C, it follows product safety standards of the U.S. and/or Canada, respectively.

The European Commission describes the Conformance European mark as a "passport" that allows manufacturers to circulate industrial products freely within the market of the E.U. The CE mark certifies that the products have met EU health, safety and environmental standards that ensure consumer and workplace safety. All manufacturers in the EU and abroad must affix the CE mark to those products covered by the "New Approach" directives in order to market their products in Europe. Once a product receives the CE mark, it can be marketed throughout the EU without undergoing further product modification. An important document related to CE is the Declaration of Conformity. It is a document which a company authority must sign to say that their device meets the requirements of the Directive. The D.O.C. must include a list of any standards used to justify the claim of compliance with the Directive.

If a Marra Forni product is stamped CE, the product does not emit excessive radiation (microwave or RF), and is not overly sensitive to picking up radiation. In summary, the certification marks on Marra Forni products are your assurance that the product meets rigorous standards for electrical safety and electromagnetic emissions. It poses no shock hazard (except as noted on the product or its manual), and it will not cause electromagnetic interference with other devices beyond a certain distance. You can use the product with confidence.



Marraforni

10310 Southard Drive Beltsville, MD 20705 1.888.239.0575 Fax. 240.667.7991 www.marraforni.com inquiries@marraforni.com