

Teacher Edition

# Eureka Math

## Grade 2

### Module 5

Special thanks go to the Gordon A. Cain Center and to the Department of Mathematics at Louisiana State University for their support in the development of *Eureka Math*.

For a free *Eureka Math* Teacher  
Resource Pack, Parent Tip  
Sheets, and more please  
visit [www.Eureka.tools](http://www.Eureka.tools)

**Published by Great Minds®.**

Copyright © 2018 Great Minds®. No part of this work may be reproduced, sold, or commercialized, in whole or in part, without written permission from Great Minds®. Noncommercial use is licensed pursuant to a Creative Commons Attribution-NonCommercial-ShareAlike 4.0 license; for more information, go to <http://greatminds.org/copyright>. *Great Minds* and *Eureka Math* are registered trademarks of Great Minds®.

Printed in the U.S.A.

This book may be purchased from the publisher at [eureka-math.org](http://eureka-math.org).

10 9 8 7 6 5 4 3 2 1

ISBN 978-1-64054-321-8

G2-M5-UTE-1.3.0-05.2018

## ***Eureka Math: A Story of Units Contributors***

Katrina Abdussalaam, Curriculum Writer  
Tiah Alphonso, Program Manager—Curriculum Production  
Kelly Alsup, Lead Writer / Editor, Grade 4  
Catriona Anderson, Program Manager—Implementation Support  
Debbie Andorka-Aceves, Curriculum Writer  
Eric Angel, Curriculum Writer  
Leslie Arceneaux, Lead Writer / Editor, Grade 5  
Kate McGill Austin, Lead Writer / Editor, Grades PreK–K  
Adam Baker, Lead Writer / Editor, Grade 5  
Scott Baldridge, Lead Mathematician and Lead Curriculum Writer  
Beth Barnes, Curriculum Writer  
Bonnie Bergstresser, Math Auditor  
Bill Davidson, Fluency Specialist  
Jill Diniz, Program Director  
Nancy Diorio, Curriculum Writer  
Nancy Doorey, Assessment Advisor  
Lacy Endo-Peery, Lead Writer / Editor, Grades PreK–K  
Ana Estela, Curriculum Writer  
Lessa Faltermann, Math Auditor  
Janice Fan, Curriculum Writer  
Ellen Fort, Math Auditor  
Peggy Golden, Curriculum Writer  
Maria Gomes, Pre-Kindergarten Practitioner  
Pam Goodner, Curriculum Writer  
Greg Gorman, Curriculum Writer  
Melanie Gutierrez, Curriculum Writer  
Bob Hollister, Math Auditor  
Kelley Isinger, Curriculum Writer  
Nuhad Jamal, Curriculum Writer  
Mary Jones, Lead Writer / Editor, Grade 4  
Halle Kananak, Curriculum Writer  
Susan Lee, Lead Writer / Editor, Grade 3  
Jennifer Loftin, Program Manager—Professional Development  
Soo Jin Lu, Curriculum Writer  
Nell McAnelly, Project Director

Ben McCarty, Lead Mathematician / Editor, PreK–5  
Stacie McClintock, Document Production Manager  
Cristina Metcalf, Lead Writer / Editor, Grade 3  
Susan Midlarsky, Curriculum Writer  
Pat Mohr, Curriculum Writer  
Sarah Oyler, Document Coordinator  
Victoria Peacock, Curriculum Writer  
Jenny Petrosino, Curriculum Writer  
Terrie Poehl, Math Auditor  
Robin Ramos, Lead Curriculum Writer / Editor, PreK–5  
Kristen Riedel, Math Audit Team Lead  
Cecilia Rudzitis, Curriculum Writer  
Tricia Salerno, Curriculum Writer  
Chris Sarlo, Curriculum Writer  
Ann Rose Sentoro, Curriculum Writer  
Colleen Sheeron, Lead Writer / Editor, Grade 2  
Gail Smith, Curriculum Writer  
Shelley Snow, Curriculum Writer  
Robyn Sorenson, Math Auditor  
Kelly Spinks, Curriculum Writer  
Marianne Strayton, Lead Writer / Editor, Grade 1  
Theresa Streeter, Math Auditor  
Lily Talcott, Curriculum Writer  
Kevin Tougher, Curriculum Writer  
Saffron VanGalder, Lead Writer / Editor, Grade 3  
Lisa Watts-Lawton, Lead Writer / Editor, Grade 2  
Erin Wheeler, Curriculum Writer  
MaryJo Wieland, Curriculum Writer  
Allison Witcraft, Math Auditor  
Jessa Woods, Curriculum Writer  
Hae Jung Yang, Lead Writer / Editor, Grade 1



## **Board of Trustees**

Lynne Munson, President and Executive Director of Great Minds

Nell McAnelly, Chairman, Co-Director Emeritus of the Gordon A. Cain Center for STEM Literacy at Louisiana State University

William Kelly, Treasurer, Co-Founder and CEO at ReelDx

Jason Griffiths, Secretary, Director of Programs at the National Academy of Advanced Teacher Education

Pascal Forgione, Former Executive Director of the Center on K-12 Assessment and Performance Management at ETS

Lorraine Griffith, Title I Reading Specialist at West Buncombe Elementary School in Asheville, North Carolina

Bill Honig, President of the Consortium on Reading Excellence (CORE)

Richard Kessler, Executive Dean of Mannes College the New School for Music

Chi Kim, Former Superintendent, Ross School District

Karen LeFever, Executive Vice President and Chief Development Officer at ChanceLight Behavioral Health and Education

Maria Neira, Former Vice President, New York State United Teachers

**This page intentionally left blank**



## Table of Contents

**GRADE 2 • MODULE 5**

## Addition and Subtraction Within 1,000 with Word Problems to 100

<b>Module Overview</b> .....	2
Topic A: Strategies for Adding and Subtracting Within 1,000 .....	10
Topic B: Strategies for Composing Tens and Hundreds Within 1,000 .....	98
<b>Mid-Module Assessment and Rubric</b> .....	161
Topic C: Strategies for Decomposing Tens and Hundreds Within 1,000 .....	172
Topic D: Student Explanations for Choice of Solution Methods .....	248
<b>End-of-Module Assessment and Rubric</b> .....	270
<b>Answer Key</b> .....	281

## Grade 2 • Module 5

# Addition and Subtraction Within 1,000 with Word Problems to 100

## OVERVIEW

In Module 4, students developed addition and subtraction fluency within 100 and began developing conceptual understanding of the standard algorithm by means of place value strategies. In Module 5, students build upon their mastery of renaming place value units and extend their work with conceptual understanding of the addition and subtraction algorithms to numbers within 1,000, always with the option of modeling with materials or drawings. Throughout the module, students continue to focus on strengthening and deepening conceptual understanding and fluency.

Topic A focuses on place value strategies to add and subtract within 1,000. Students relate *100 more* and *100 less* to addition and subtraction of 100. They add and subtract multiples of 100, including counting on to subtract (e.g., for  $650 - 300$ , they start at 300 and think, “300 more gets me to 600, and 50 more gets me to 650, so ... 350”). Students also use simplifying strategies for addition and subtraction. They extend the make a ten strategy to make a hundred, mentally decomposing one addend to make a hundred with the other (e.g.,  $299 + 6$  becomes  $299 + 1 + 5$ , or  $300 + 5$ , which equals 305) and use compensation to subtract from three-digit numbers (e.g., for  $376 - 59$ , add 1 to each,  $377 - 60 = 317$ ). The topic ends with students sharing and critiquing solution strategies for addition and subtraction problems. Throughout the topic, students use place value language and properties of operations to explain why their strategies work.

In Topics B and C, students continue to build on Module 4’s work, now composing and decomposing tens and hundreds within 1,000. As each topic begins, students relate manipulative representations to the algorithm and then transition to creating math drawings in place of the manipulatives. As always, students use place value reasoning and properties of operations to explain their work.

Throughout Module 5, students maintain addition and subtraction fluency within 100 as they use these skills during their daily application work to solve one- and two-step word problems of all types. The Application Problem precedes fluency activities in most lessons of Module 5 because this work with smaller numbers does not flow directly into the Concept Development. The focus of the Concept Development is adding and subtracting within 1,000: using concrete models or drawings and strategies based on place value, properties of operations, and/or the relationship between addition and subtraction, and relating strategies to a written method. Note that a written method can include number bonds, chip models, arrow notation, the algorithm, or tape diagrams. Many students will need to record these strategies to solve correctly. The lessons are designed to provide ample time for discussions that center on student reasoning, explaining why their addition and subtraction strategies work. For example, students may use the relationship between addition and subtraction to demonstrate why their subtraction solution is correct.

The module culminates with Topic D, wherein students synthesize their understanding of addition and subtraction strategies and choose which strategy is most efficient for given problems. They defend their choices using place value language and their understanding of the properties of operations.

Note that, beginning in Topic C, and for the remainder of the year, each day’s Fluency Practice includes an opportunity for review and mastery of the sums and differences with totals through 20 by means of the Core Fluency Practice Sets or Sprints.

The Mid-Module Assessment follows Topic B. The End-of-Module Assessment follows Topic D.

**Notes on Pacing for Differentiation**

If pacing is a challenge, consider the following modifications. The lessons that follow Topic A in Module 5 could be paced more quickly as students readily grasp the concepts.

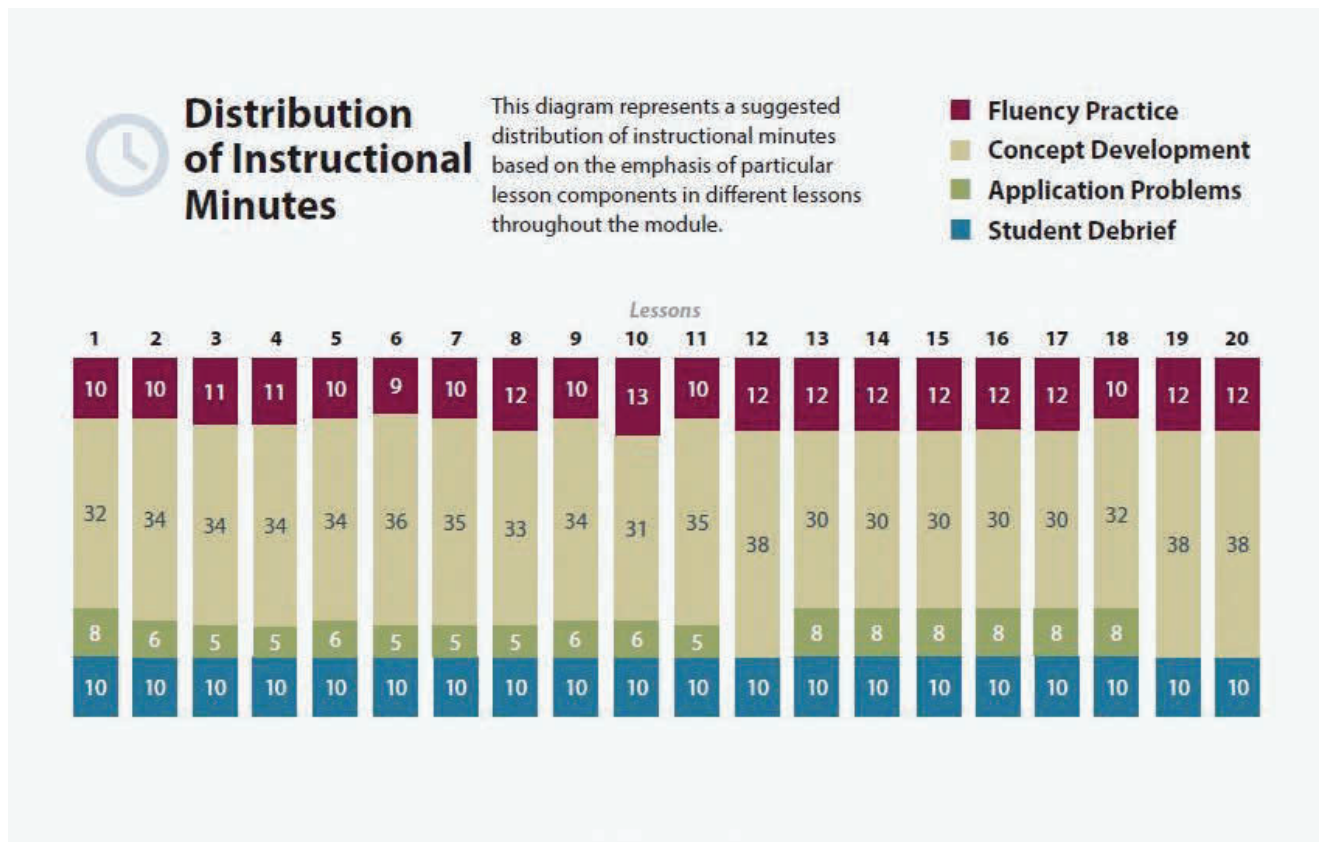

## Focus Grade Level Standards

### Use place value understanding and properties of operations to add and subtract.<sup>1</sup>

- Add and subtract within 1000, using concrete models or drawings and strategies based on place value, properties of operations, and/or the relationship between addition and subtraction; relate the strategy to a written method. Understand that in adding or subtracting three-digit numbers, one adds or subtracts hundreds and hundreds, tens and tens, ones and ones; and sometimes it is necessary to compose or decompose tens or hundreds.
- Mentally add 10 or 100 to a given number 100–900, and mentally subtract 10 or 100 from a given number 100–900.
- Explain why addition and subtraction strategies work, using place value and the properties of operations. (Explanations may be supported by drawings or objects.)

## Foundational Standards

- Apply properties of operations as strategies to add and subtract. *Examples: If  $8 + 3 = 11$  is known, then  $3 + 8 = 11$  is also known. (Commutative property of addition.) To add  $2 + 6 + 4$ , the second two numbers can be added to make a ten, so  $2 + 6 + 4 = 2 + 10 = 12$ . (Associative property of addition.)*
- Understand subtraction as an unknown-addend problem. *For example, subtract  $10 - 8$  by finding the number that makes 10 when added to 8.*
- Given a two-digit number, mentally find 10 more or 10 less than the number, without having to count; explain the reasoning used.
- Subtract multiples of 10 in the range 10–90 from multiples of 10 in the range 10–90 (positive or zero differences), using concrete models or drawings and strategies based on place value, properties of operations, and/or the relationship between addition and subtraction; relate the strategy to a written method and explain the reasoning used.
- Understand that the three digits of a three-digit number represent amounts of hundreds, tens, and ones; e.g., 706 equals 7 hundreds, 0 tens, and 6 ones. Understand the following as special cases:
  - 100 can be thought of as a bundle of ten tens—called a “hundred.”
  - The numbers 100, 200, 300, 400, 500, 600, 700, 800, 900 refer to one, two, three, four, five, six, seven, eight, or nine hundreds (and 0 tens and 0 ones).

<sup>1</sup>The balance of this cluster is addressed in Modules 1 and 4.

- Count within 1000; skip-count by 5s, 10s, and 100s.
- Read and write numbers to 1000 using base-ten numerals, number names, and expanded form.
- Fluently add and subtract within 100 using strategies based on place value, properties of operations, and/or the relationship between addition and subtraction.

## Focus Standards for Mathematical Practice

- **Construct viable arguments and critique the reasoning of others.** Students use place value reasoning to explain how each step in their drawing relates to a step in the algorithm. They choose and explain various solution strategies such as number bonds, chip models, vertical form, arrow notation, and tape diagrams. They critique the reasoning of others when they listen to peers explain their strategies for solving problems and then discuss the efficacy of those strategies.
- **Attend to precision.** Students attend to precision when they use place value language to explain their math drawings and calculations. They articulate the arithmetic properties they use to solve a variety of problems. For example, when adding  $825 + 80$ , a student may show understanding of the associative property by saying, “I know that  $20 + 80$  equals 100, so I added  $800 + 100 + 5$ , which equals 905.”
- **Look for and make use of structure.** Students look for and make use of the base ten structure when composing and decomposing. They extend their understanding from Module 4, viewing 10 tens as forming a new unit called a *hundred*, just as they understand that 10 ones forms 1 ten. They apply this understanding of base ten structure when adding and subtracting three-digit numbers, repeatedly bundling and unbundling groups of ten. Students also make use of structure when they use simplifying strategies, such as compensation, to create a multiple of ten or a hundred.
- **Look for and express regularity in repeated reasoning.** As students repeatedly manipulate models and record the work abstractly, they recognize the cyclic pattern of the addition or subtraction of like units and the subsequent potential composition or decomposition of units through the place values. They see that the vertical form represents the same cycle they use with the manipulatives.

## Overview of Module Topics and Lesson Objectives

Topics and Objectives		Days
A	<p><b>Strategies for Adding and Subtracting Within 1,000</b></p> <p>Lesson 1: Relate 10 more, 10 less, 100 more, and 100 less to addition and subtraction of 10 and 100.</p> <p>Lesson 2: Add and subtract multiples of 100, including counting on to subtract.</p> <p>Lesson 3: Add multiples of 100 and some tens within 1,000.</p> <p>Lesson 4: Subtract multiples of 100 and some tens within 1,000.</p> <p>Lesson 5: Use the associative property to make a hundred in one addend.</p> <p>Lesson 6: Use the associative property to subtract from three-digit numbers and verify solutions with addition.</p> <p>Lesson 7: Share and critique solution strategies for varied addition and subtraction problems within 1,000.</p>	7
B	<p><b>Strategies for Composing Tens and Hundreds Within 1,000</b></p> <p>Lessons 8–9: Relate manipulative representations to the addition algorithm.</p> <p>Lessons 10–11: Use math drawings to represent additions with up to two compositions and relate drawings to the addition algorithm.</p> <p>Lesson 12: Choose and explain solution strategies and record with a written addition method.</p>	5
Mid-Module Assessment: Topics A–B (assessment 1/2 day, return 1/2 day, remediation or further applications 1 day)		2





Topics and Objectives		Days
<b>C</b>	<b>Strategies for Decomposing Tens and Hundreds Within 1,000</b> Lesson 13: Relate manipulative representations to the subtraction algorithm, and use addition to explain why the subtraction method works. Lessons 14–15: Use math drawings to represent subtraction with up to two decompositions, relate drawings to the algorithm, and use addition to explain why the subtraction method works. Lessons 16–17: Subtract from multiples of 100 and from numbers with zero in the tens place. Lesson 18: Apply and explain alternate methods for subtracting from multiples of 100 and from numbers with zero in the tens place.	6
<b>D</b>	<b>Student Explanations for Choice of Solution Methods</b> Lessons 19–20: Choose and explain solution strategies and record with a written addition or subtraction method.	2
	End-of-Module Assessment: Topics A–D (assessment 1/2 day, return 1/2 day, remediation or further applications 1 day)	2
<b>Total Number of Instructional Days</b>		<b>24</b>

## Terminology

### New or Recently Introduced Terms

- Compensation (simplifying strategy where students add or subtract the same amount to or from both numbers to create an equivalent, but simpler, problem)

### Familiar Terms and Symbols<sup>2</sup>

- Addend
- Addition
- Algorithm
- Bundle
- Compose
- Decompose
- Difference
- Equation

<sup>2</sup>These are terms and symbols students have seen previously.

- New groups below
- Number bond
- Place value
- Place value chart (pictured to the right)
- Place value or number disk (pictured to the right)
- Rename
- Simplifying strategy
- Subtraction
- Tape diagram
- Total
- Unbundle
- Units of ones, tens, hundreds

Place Value Disks

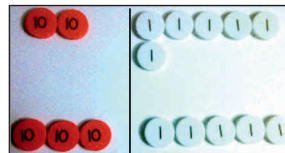
Place Value Chart Without Headings  
(use with place value disks)

--	--	--

Place Value Chart with Headings  
(use with numbers and chips)

hundreds	tens	ones
7	2	6

## Suggested Tools and Representations

- Arrow notation, arrow way
- Chip model (pictured below)
- Hide Zero cards
- Number bond
- Personal white boards
- Place value charts (pictured above to the right)
- Place value disk sets (19 ones, 19 tens, 10 hundreds, 1 one thousand per set)
- Tape diagram

Note: Students work through a progression of models to represent the addition and subtraction algorithm. Following the use of actual place value disks, students learn to draw the disks to represent numbers. This model provides an added level of support in that students write the value on each disk (pictured below to the left). Because the value is on the disk, there is no need to label the place value chart. Next, students learn the chip model, drawing dots on a labeled place value chart (pictured below to the right). While still pictorial, this model is more abstract because the value of the chip derives from its placement on the chart.

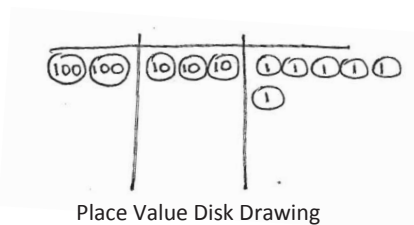

Place Value Disk Drawing

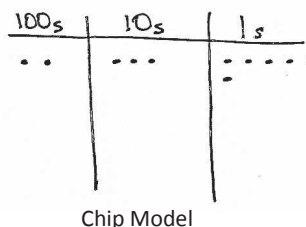

Chip Model

## Scaffolds<sup>3</sup>

The scaffolds integrated into *A Story of Units* give alternatives for how students access information as well as express and demonstrate their learning. Strategically placed margin notes are provided within each lesson elaborating on the use of specific scaffolds at applicable times. They address many needs presented by English language learners, students with disabilities, students performing above grade level, and students performing below grade level. Many of the suggestions are organized by Universal Design for Learning (UDL) principles and are applicable to more than one population. To read more about the approach to differentiated instruction in *A Story of Units*, please refer to “How to Implement *A Story of Units*.”

## Assessment Summary

Type	Administered	Format
Mid-Module Assessment Task	After Topic B	Constructed response with rubric
End-of-Module Assessment Task	After Topic D	Constructed response with rubric

<sup>3</sup>Students with disabilities may require Braille, large print, audio, or special digital files. Please visit [greatminds.org/contact](http://greatminds.org/contact) to request information on how to obtain student materials that satisfy the National Instructional Materials Accessibility Standard (NIMAS) format.



## Topic A

# Strategies for Adding and Subtracting Within 1,000

- Focus Standards:**
- Add and subtract within 1000, using concrete models or drawings and strategies based on place value, properties of operations, and/or the relationship between addition and subtraction; relate the strategy to a written method. Understand that in adding or subtracting three-digit numbers, one adds or subtracts hundreds and hundreds, tens and tens, ones and ones; and sometimes it is necessary to compose or decompose tens or hundreds.
  - Mentally add 10 or 100 to a given number 100–900, and mentally subtract 10 or 100 from a given number 100–900.
  - Explain why addition and subtraction strategies work, using place value and the properties of operations. (Explanations may be supported by drawings or objects.)

**Instructional Days:** 7

**Coherence -Links from:** G1–M6 Place Value, Comparison, Addition and Subtraction to 100

**-Links to:** G3–M2 Place Value and Problem Solving with Units of Measure

In Topic A, students practice the simplifying strategies they learned in Module 4 but with numbers up to 1,000. They are asked to consider which strategy is most efficient for each problem they encounter.

In Lesson 1, students relate *100 more*, *100 less*, *10 more*, and *10 less* to addition and subtraction. They recognize that they must still add and subtract like units and that the digit in the hundreds place changes when adding and subtracting 100, just as the digit in the tens place changes when adding or subtracting 10. Students see numbers in terms of place value units:  $290 - 100$  is 2 hundreds 9 tens minus 1 hundred. They learn to record the addition and subtraction of multiples of 100 using arrow notation (i.e., the arrow way).

In Lesson 2, students add and subtract multiples of 100 by counting on by hundreds. For example, when adding 200 to 320, they may count up from 320: 420, 520. Students also develop flexibility in terms of using related addition problems. For example, to solve  $519 - 200$ , one student might think, “5 hundreds minus 2 hundreds is 3 hundreds, plus 19 is 319,” while another starts at 200, adds on 19, and then 3 hundreds to reach 519, so 319.

$$320 + 200$$

$$320 \xrightarrow{+100} 420 \xrightarrow{+100} 520$$

In Lessons 3 and 4, students continue to add and subtract multiples of 100 with the added complexity of some tens. Problems are chosen so that, at first, the tens digit is close to a multiple of 100 (e.g., 190, 290, 380) to make it easier to form the next hundred by decomposing addends. This prompts students to analyze and use relationships between numbers to develop a variety of simplifying strategies.

Students also use arrow notation to record their mental math. First, they add a multiple of 100, and then they count on by multiples of 10 to find the total (as shown to the right). Lesson 3 focuses on addition, while Lesson 4 emphasizes related strategies for subtraction.

$$\begin{array}{l} 320 + 270 \\ 320 \xrightarrow{+200} 520 \xrightarrow{+70} 590 \end{array}$$

In Lesson 5, students apply the use of number bonds to decompose larger numbers, just as they did with numbers within 100. For example, when solving  $320 + 290$ , they can break 320 into 10 and 310 to make  $310 + 300 = 610$  (as shown below), just as they would have decomposed to add 32 and 29 in Module 4. They realize the problem can be conceived as 32 tens + 29 tens. Note that arrow notation can also be used to solve  $320 + 290$  by first adding 200, then 80, and then 10, or by adding 300, and then subtracting 10. Students work with problems, such as  $298 + 137$ , using a number bond to decompose 137 into 2 and 135, thus creating the equivalent but simpler equation  $300 + 135 = 435$ .

$$\begin{array}{l} 320 + 290 = 310 + 300 \\ \begin{array}{l} \diagup \quad \diagdown \\ 310 \quad 10 \end{array} \\ = 610 \end{array}$$

*I can decompose 320 as 10 and 310 to make 300 and 310.*

In Lesson 6, the ease of subtracting a multiple of 100 is highlighted again as students extend their work from Module 4 using compensation (i.e., the associative property) for subtraction. Students may add or subtract a multiple of 10 to make an equivalent problem that involves no renaming. For example, when subtracting  $610 - 290$ , the same number, 10, can be added to both numbers to create a multiple of 100 (as shown below). Students also solve problems such as  $451 - 195$ , adding 5 to both the minuend and subtrahend to make  $456 - 200$ .

$$\begin{array}{l} 610 - 290 = 620 - 300 \\ = 320 \end{array}$$

*If I add the same amount to both numbers, the difference stays the same!*

Topic A closes with Lesson 7, which provides students the opportunity to solidify their new skills. They confront a variety of problems, solve them, and then share their solution strategies. Through spirited discussion, students critique the work of their peers while deepening their understanding of various strategies.

The strategies taught in Topic A are designed to develop students' conceptual understanding of addition and subtraction using models, drawings, properties of operations, and strategies based on place value. At the same time, students relate these strategies to written methods such as arrow notation and number bonds. This sets the stage for flexible thinking as students move into composing and decomposing units in Topics B and C.

**A Teaching Sequence Toward Mastery of Strategies for Adding and Subtracting Within 1,000**

**Objective 1:** Relate 10 more, 10 less, 100 more, and 100 less to addition and subtraction of 10 and 100.  
(Lesson 1)

**Objective 2:** Add and subtract multiples of 100, including counting on to subtract.  
(Lesson 2)

**Objective 3:** Add multiples of 100 and some tens within 1,000.  
(Lesson 3)

**Objective 4:** Subtract multiples of 100 and some tens within 1,000.  
(Lesson 4)

**Objective 5:** Use the associative property to make a hundred in one addend.  
(Lesson 5)

**Objective 6:** Use the associative property to subtract from three-digit numbers and verify solutions with addition.  
(Lesson 6)

**Objective 7:** Share and critique solution strategies for varied addition and subtraction problems within 1,000.  
(Lesson 7)

## Lesson 1

**Objective:** Relate 10 more, 10 less, 100 more, and 100 less to addition and subtraction of 10 and 100.

### Suggested Lesson Structure

■ Fluency Practice	(10 minutes)
■ Application Problem	(8 minutes)
■ Concept Development	(32 minutes)
■ Student Debrief	(10 minutes)
<b>Total Time</b>	<b>(60 minutes)</b>

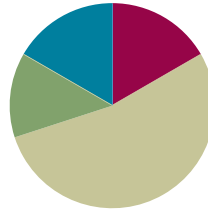

### Fluency Practice (10 minutes)

- Place Value (6 minutes)
- More/Less (4 minutes)

#### Place Value (6 minutes)

**Materials:** (T) Hundreds place value chart (Template 1) (S) Personal white board, hundreds place value chart (Template 1)

**Note:** Practicing place value skills prepares students for adding and subtracting 10 and 100 in today's lesson.

T: (Project place value chart to the hundreds.) Show 6 ones in chips. Write the number below it.

S: (Draw 6 chips in the ones column, and write 6 below it.)

T: Show 1 chip in the tens column, and write the number below it.

S: (Draw 1 chip in the tens column, and write 1 at the bottom of the tens column.)

T: The Say Ten way?

S: 1 ten 6.

T: Say the number in standard form.

S: 16.

T: Add 1 chip to your tens column. What is 10 more than 16?

S: 26.

T: The Say Ten way?

S: 2 tens 6.

T: Now, add 1 chip to your hundreds column. What is 100 more than 26?

S: 126.

T: The Say Ten way?

S: 1 hundred 2 tens 6.

T: Cross out a chip in the tens column. What is 10 less than 126?

S: 116.

T: The Say Ten way?

S: 1 hundred 1 ten 6.

T: Cross out a chip in the hundreds column. What is 100 less than 116?

S: 16.

Continue with the following possible sequence: 254, 310, and 505.

### More/Less (4 minutes)

Note: Giving 10 or 100 *more* or *less* prepares students to add and subtract 10 and 100 fluently.

T: For every number I say, you say a number that is 10 more. When I say 5, you say 15. Ready?

T: 5.

S: 15.

T: 10.

S: 20.

Continue with the following possible sequence: 19, 67, 90, 95, 110, 111, 139, 156, 256, 299, 305, and 319.

T: Now, for every number I say, you say a number that is 10 less. When I say 20, you say 10. Ready?

T: 20.

S: 10.

T: 22.

S: 12.

Continue with the following possible sequence: 19, 78, 100, 107, 182, 201, 299, 312, and 321.

T: For every number I say, you say a number that is 100 more. When I say 56, you say 156. Ready?

T: 56.

S: 156.

T: 37.

S: 137.

Continue with the following possible sequence: 80, 8, 88, 288, 300, 333, 566, and 900.

T: Now, for every number I say, you say a number that is 100 less. When I say 150, you say 50. Ready?

T: 150.

S: 50.

T: 159.

S: 59.

Continue with the following possible sequence: 168, 170, 270, 277, 400, 404, and 434.



**Application Problem (8 minutes)**

The shelter rescued 27 kittens in June. In July, 11 kittens were rescued. In August, 40 more were rescued.

- How many kittens did the shelter rescue during those 3 months?
- If 64 of those kittens found homes by the end of August, how many still needed homes?



The shelter rescued 78 kittens in all.

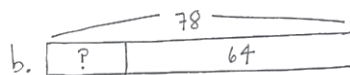

14 kittens still needed homes at the end of August.

$$27 + 11 = 38$$

$$27 \xrightarrow{+10} 37 \xrightarrow{+1} 38$$

$$38 + 40 = 78$$



$$78 - 64 = 14$$

$$78 \xrightarrow{-60} 18 \xrightarrow{-4} 14$$

Note: This problem is designed to lead into the Concept Development for today's lesson, relating 10 more and 10 less to addition and subtraction. Students complete this problem independently to provide insight into the kinds of mental strategies they currently use.

Review the RDW procedure for problem solving: Read the problem, draw and label, write a number sentence, and write a word sentence. The more students participate in reasoning through problems with a systematic approach, the more they internalize those behaviors and thought processes.

(Excerpted from "How to Implement *A Story of Units*.")

**Concept Development (32 minutes)**

Materials: (T) Set of sentence frames as shown to the right (S) 7 hundreds disks, 9 tens disks, 9 ones disks, personal white board, unlabeled hundreds place value chart (Template 2)

10 more than \_\_\_ is \_\_\_\_.  
\_\_\_ is 10 more than \_\_\_\_.

10 less than \_\_\_ is \_\_\_\_.  
\_\_\_ is 10 less than \_\_\_\_.

100 more than \_\_\_ is \_\_\_\_.  
\_\_\_ is 100 more than \_\_\_\_.

100 less than \_\_\_ is \_\_\_\_.  
\_\_\_ is 100 less than \_\_\_\_.

Post *more* sentence frames on one side of the board and *less* frames on the other side. Pass out charts and place value disks.

- T: Use your place value disks to show me 157 on your place value chart.
- S: (Show 1 hundred 5 tens 7 ones.)
- T: Show me 10 more.
- S: (Add a tens disk to show 1 hundred 6 tens 7 ones.)
- T: Use a sentence frame to describe adding 10 to 157.
- S: 10 more than 157 is 167. → 167 is 10 more than 157.
- T: What did you do to change 157?
- S: We added 10 to the tens place. → We added 1 ten to 5 tens.



**NOTES ON  
MULTIPLE MEANS  
OF REPRESENTATION:**

Use different models to demonstrate the change in 10 more, 10 less, 100 more, and 100 less.

- Use Hide Zero cards to show the changes in place value.
- Use concrete objects other than place value disks, such as bundled straws or base ten blocks, to show new groups of hundreds and new groups of tens.

T: Give me an addition sentence starting with 157.

S:  $157 + 10 = 167$ .

T: Start with 167.

S:  $167 = 10 + 157$ .  $\rightarrow 167 = 157 + 10$ .

(Repeat the process for 10 less than 157.)

T: Show me 157 again. (Pause as students reset their place value charts.)

T: Show me 100 more than 157.

S: (Add a hundreds disk to show 2 hundreds 5 tens 7 ones.)

T: Use a sentence frame to describe adding 100 to 157.

S: 257 is 100 more than 157.  $\rightarrow$  100 more than 157 is 257.

T: What did you do to change 157?

S: We added another hundred.  $\rightarrow$  We added 1 hundred to 1 hundred.

T: Be specific. Where did you add the hundred?

S: To the hundreds place.

T: Yes!

T: Give me an addition sentence starting with 157.

S:  $157 + 100 = 257$ .

T: Start with 257.

S:  $257 = 100 + 157$ .  $\rightarrow 257 = 157 + 100$ .

Repeat the process for 100 less than 157.

T: Talk with your partner. Use place value language to explain what you understand about 10 more, 10 less, 100 more, and 100 less. (Allow about one minute for discussion.)

S: We already knew about 10 more and 10 less, and now 100 acts the same.  $\rightarrow$  10 less or 100 less is the same as taking away 10 or 100.  $\rightarrow$  We have to subtract and add the same units, so the tens place changes when we add or subtract 10. The same for the hundreds place.

T: (Collect the place value disks and place value charts.) Listen as I say a number pattern. Raise your hand when you know the *more* or *less* rule for my pattern.

T: For example, if I say, “121, 131, 141, 151, 161,” you say, “10 more.” Wait for my signal. Ready?

T: 135, 145, 155, 165, 175.

S: 10 more!

T: 282, 272, 262, 252, 242.

S: 10 less!

Continue until students can readily identify the rule.

T: Take out your personal white board. Now, I’ll write a series of numbers on the board. You write the rule and the next three numbers. The rules are  $+ 10$ ,  $- 10$ ,  $+ 100$ , and  $- 100$ .



### NOTES ON MULTIPLE MEANS OF ACTION AND EXPRESSION:

Listen intently as students use place value language to talk with their partners. Use place value disks and place value charts to help students navigate the following vocabulary: *place value*, *hundreds*, *tens*, *ones*, *digit*, *value*, and *unit*. Add new vocabulary to the wall and point to words accompanied by a visual.

T: Turn your personal white board over after you have written your answer. Wait until I say, “Show me.” Ready?

T: (Write 67, 57, 47, \_\_\_\_, \_\_\_\_, \_\_\_\_. Pause.) Show me.

S: (Show – 10 and 37, 27, 17.)

Continue to give students practice with each rule.

In this next activity, model arrow notation by recording the following sequence on the board step-by-step as students write each answer.

$$542 \xrightarrow{+100} \underline{\quad} \xrightarrow{-10} \underline{\quad} \xrightarrow{-10} \underline{\quad} \xrightarrow{-100} \underline{\quad} \xrightarrow{-100} \underline{\quad}.$$

T: Let’s try something different. (Write  $542 \xrightarrow{+100} \underline{\quad}$  on the board.) What is  $542 + 100$ ? Show me.

S: (Write 642.)

T: Minus 10? (Continue to record the sequence by filling in 642 and writing  $\xrightarrow{-10} \underline{\quad}$ .)

S: (Write 632.)

T: Minus 10? (Fill in 632 and write  $\xrightarrow{-10} \underline{\quad}$ .)

S: (Write 622.)

T: Minus 100? (Fill in 622 and write  $\xrightarrow{-100} \underline{\quad}$ .)

S: (Write 522.)

T: Minus 100? (Fill in 522 and write  $\xrightarrow{-100} \underline{\quad}$ .)

S: (Write 422.)

$$542 \xrightarrow{+100} 642 \xrightarrow{-10} 632 \xrightarrow{-10} 622 \xrightarrow{-100} 522 \xrightarrow{-100} 422$$

T: (Point to the completed sequence on the board.) In the last module, we used this simplifying strategy. We called it the arrow way. Talk to your partner about how this example is the same as and different from the ones we’ve done before.

S: Instead of ones and tens, this is tens and hundreds. → It’s just different place values. Everything else is the same. → It shows that you’re changing the tens or the hundreds place and whether it’s more or less.

If necessary or if time permits, model another example with the following problem:

$$367 - 220.$$

$$367 \xrightarrow{-100} \underline{\quad} \xrightarrow{-100} \underline{\quad} \xrightarrow{-10} \underline{\quad} \xrightarrow{-10} \underline{\quad}.$$

### Problem Set (10 minutes)

Students should do their personal best to complete the Problem Set within the allotted 10 minutes. Some problems do not specify a method for solving. This is an intentional reduction of scaffolding. Students should solve these problems using the RDW approach used for Application Problems.

For some classes, it may be appropriate to modify the assignment by specifying which problems students should work on first. With this option, let the purposeful sequencing of the Problem Set guide the selections so that problems continue to be scaffolded. Balance word problems with other problem types to ensure a range of practice. Consider assigning incomplete problems for homework or at another time during the day.

### Student Debrief (10 minutes)

**Lesson Objective:** Relate 10 more, 10 less, 100 more, and 100 less to addition and subtraction of 10 and 100.

The Student Debrief is intended to invite reflection and active processing of the total lesson experience.

Invite students to review their solutions for the Problem Set. They should check work by comparing answers with a partner before going over answers as a class. Look for misconceptions or misunderstandings that can be addressed in the Student Debrief. Guide students in a conversation to debrief the Problem Set and process the lesson.

Any combination of the questions below may be used to lead the discussion.

- What makes Problems 1(e) and (f) more challenging? In Problem 1(e), does *10 more* mean we should add 10 to 319? Why not? In Problem 1(f), why did you add 100 to 499 when it says *100 less*?
- What do you need to know to complete each pattern in Problem 2?
- In Problem 3(b), what total quantity did you subtract from 187? How can you write it as an equation?
- In Problem 4(b), what total quantity did you add to 323 to arrive at 400? How did you show the missing addend using the arrow way? How can we show it as an equation?
- Which simplifying strategy did we use today to record a sequence of numbers? How is it helpful?

Name Ben Date \_\_\_\_\_

1. Complete each *more* or *less* statement.

a. 10 more than 175 is 185      b. 100 more than 175 is 275  
 c. 10 less than 175 is 165      d. 100 less than 175 is 75  
 e. 319 is 10 more than 309      f. 499 is 100 less than 599  
 g. 788 is 100 less than 888.      h. 503 is 10 more than 493.  
 i. 898 is 100 less than 998.      j. 607 is 10 more than 597.  
 k. 10 more than 309 is 319      l. 309 is 10 less than 319.

2. Complete each regular number pattern.

a. 170, 180, 190, 200, 210, 220  
 b. 420, 410, 400, 390, 380, 370  
 c. 789, 689, 589, 489, 389, 289  
 d. 565, 575, 585, 595, 605, 615  
 e. 724, 714, 704, 694, 684, 674  
 f. 916, 906, 896, 886, 876, 866

3. Complete each statement.

a.  $389 \xrightarrow{+10} 399 \xrightarrow{+100} 499$       b.  $187 \xrightarrow{-100} 87 \xrightarrow{-10} 77$   
 c.  $609 \xrightarrow{-10} 599 \xrightarrow{-100} 499 \xrightarrow{+10} 509 \xrightarrow{+10} 519$   
 d.  $512 \xrightarrow{-10} 502 \xrightarrow{-10} 492 \xrightarrow{+100} 592 \xrightarrow{+100} 692 \xrightarrow{+10} 702$

4. Solve using the arrow way.

a.  $210 + 130 = 340$   
 $210 \xrightarrow{+100} 310 \xrightarrow{+10} 320 \xrightarrow{+10} 330 \xrightarrow{+10} 340$

b.  $320 + \underline{80} = 400$   
 $320 \xrightarrow{+10} 330 \xrightarrow{+10} 340 \xrightarrow{+10} 350 \xrightarrow{+10} 360 \xrightarrow{+10} 370 \xrightarrow{+10} 380 \xrightarrow{+10} 390 \xrightarrow{+10} 400$

c.  $220 + 515 = 735$   
 $515 \xrightarrow{+100} 615 \xrightarrow{+10} 715 \xrightarrow{+10} 725 \xrightarrow{+10} 735$

- What important connection did we make today? What are we actually doing when we talk about 10 more, 10 less, 100 more, or 100 less than a number?

**Exit Ticket (3 minutes)**

After the Student Debrief, instruct students to complete the Exit Ticket. A review of their work will help with assessing students' understanding of the concepts that were presented in today's lesson and planning more effectively for future lessons. The questions may be read aloud to the students.

Name \_\_\_\_\_

Date \_\_\_\_\_

1. Complete each *more* or *less* statement.

- a. 10 more than 175 is \_\_\_\_\_.
- b. 100 more than 175 is \_\_\_\_\_.
- c. 10 less than 175 is \_\_\_\_\_.
- d. 100 less than 175 is \_\_\_\_\_.
- e. 319 is 10 more than \_\_\_\_\_.
- f. 499 is 100 less than \_\_\_\_\_.
- g. \_\_\_\_\_ is 100 less than 888.
- h. \_\_\_\_\_ is 10 more than 493.
- i. 898 is \_\_\_\_\_ than 998.
- j. 607 is \_\_\_\_\_ than 597.
- k. 10 more than 309 is \_\_\_\_\_.
- l. 309 is \_\_\_\_\_ than 319.

2. Complete each regular number pattern.

- a. 170, 180, 190, \_\_\_\_\_, \_\_\_\_\_, \_\_\_\_\_
- b. 420, 410, 400, \_\_\_\_\_, \_\_\_\_\_, \_\_\_\_\_
- c. 789, 689, \_\_\_\_\_, \_\_\_\_\_, \_\_\_\_\_, 289
- d. 565, 575, \_\_\_\_\_, \_\_\_\_\_, \_\_\_\_\_, 615
- e. 724, \_\_\_\_\_, \_\_\_\_\_, \_\_\_\_\_, 684, 674
- f. \_\_\_\_\_, \_\_\_\_\_, \_\_\_\_\_, 886, 876, 866

3. Complete each statement.

a.  $389 \xrightarrow{+10} \underline{\hspace{2cm}} \xrightarrow{+100} \underline{\hspace{2cm}}$

b.  $187 \xrightarrow{-100} \underline{\hspace{2cm}} \xrightarrow{-10} \underline{\hspace{2cm}}$

c.  $609 \xrightarrow{-10} \underline{\hspace{2cm}} \xrightarrow{-\underline{\hspace{1cm}}} 499 \xrightarrow{+10} \underline{\hspace{2cm}} \xrightarrow{+\underline{\hspace{1cm}}} 519$

d.  $512 \xrightarrow{-10} \underline{\hspace{2cm}} \xrightarrow{-10} \underline{\hspace{2cm}} \xrightarrow{+100} \underline{\hspace{2cm}} \xrightarrow{+100} \underline{\hspace{2cm}} \xrightarrow{+10} \underline{\hspace{2cm}}$

4. Solve using the arrow way.

a.  $210 + 130 = \underline{\hspace{2cm}}$

b.  $320 + \underline{\hspace{2cm}} = 400$

c.  $\underline{\hspace{2cm}} + 515 = 735$

Name \_\_\_\_\_

Date \_\_\_\_\_

Solve using the arrow way.

1.  $440 + 220 = \underline{\hspace{2cm}}$

2.  $670 + \underline{\hspace{2cm}} = 890$

3.  $\underline{\hspace{2cm}} + 765 = 945$



Name \_\_\_\_\_

Date \_\_\_\_\_

1. Complete each *more* or *less* statement.

- a. 10 more than 222 is \_\_\_\_\_.
- b. 100 more than 222 is \_\_\_\_\_.
- c. 10 less than 222 is \_\_\_\_\_.
- d. 100 less than 222 is \_\_\_\_\_.
- e. 515 is 10 more than \_\_\_\_\_.
- f. 299 is 100 less than \_\_\_\_\_.
- g. \_\_\_\_\_ is 100 less than 345.
- h. \_\_\_\_\_ is 10 more than 397.
- i. 898 is \_\_\_\_\_ than 998.
- j. 607 is \_\_\_\_\_ than 597.
- k. 10 more than 309 is \_\_\_\_\_.
- l. 309 is \_\_\_\_\_ than 319.

2. Complete each regular number pattern.

- a. 280, 290, \_\_\_\_\_, \_\_\_\_\_, \_\_\_\_\_, 330
- b. 530, 520, 510, \_\_\_\_\_, \_\_\_\_\_, \_\_\_\_\_
- c. 643, 543, \_\_\_\_\_, \_\_\_\_\_, \_\_\_\_\_, 143
- d. 681, 691, \_\_\_\_\_, \_\_\_\_\_, \_\_\_\_\_, 731
- e. 427, \_\_\_\_\_, \_\_\_\_\_, \_\_\_\_\_, 387, 377
- f. \_\_\_\_\_, \_\_\_\_\_, \_\_\_\_\_, 788, 778, 768

3. Complete each statement.

a.  $235 \xrightarrow{+10} \underline{\hspace{2cm}} \xrightarrow{+100} \underline{\hspace{2cm}}$

b.  $391 \xrightarrow{-100} \underline{\hspace{2cm}} \xrightarrow{-10} \underline{\hspace{2cm}}$

c.  $417 \xrightarrow{-10} \underline{\hspace{2cm}} \xrightarrow{-\underline{\hspace{1cm}}} \underline{\hspace{2cm}} \xrightarrow{-100} 297$

d.  $311 \xrightarrow{-10} \underline{\hspace{2cm}} \xrightarrow{-10} \underline{\hspace{2cm}} \xrightarrow{+100} \underline{\hspace{2cm}} \xrightarrow{+100} \underline{\hspace{2cm}} \xrightarrow{+10} \underline{\hspace{2cm}}$

4. Solve using the arrow way.

a.  $370 + 110 = \underline{\hspace{2cm}}$

b.  $290 + \underline{\hspace{2cm}} = 400$

c.  $\underline{\hspace{2cm}} + 710 = 850$

ones	
tens	
hundreds	

---

hundreds place value chart

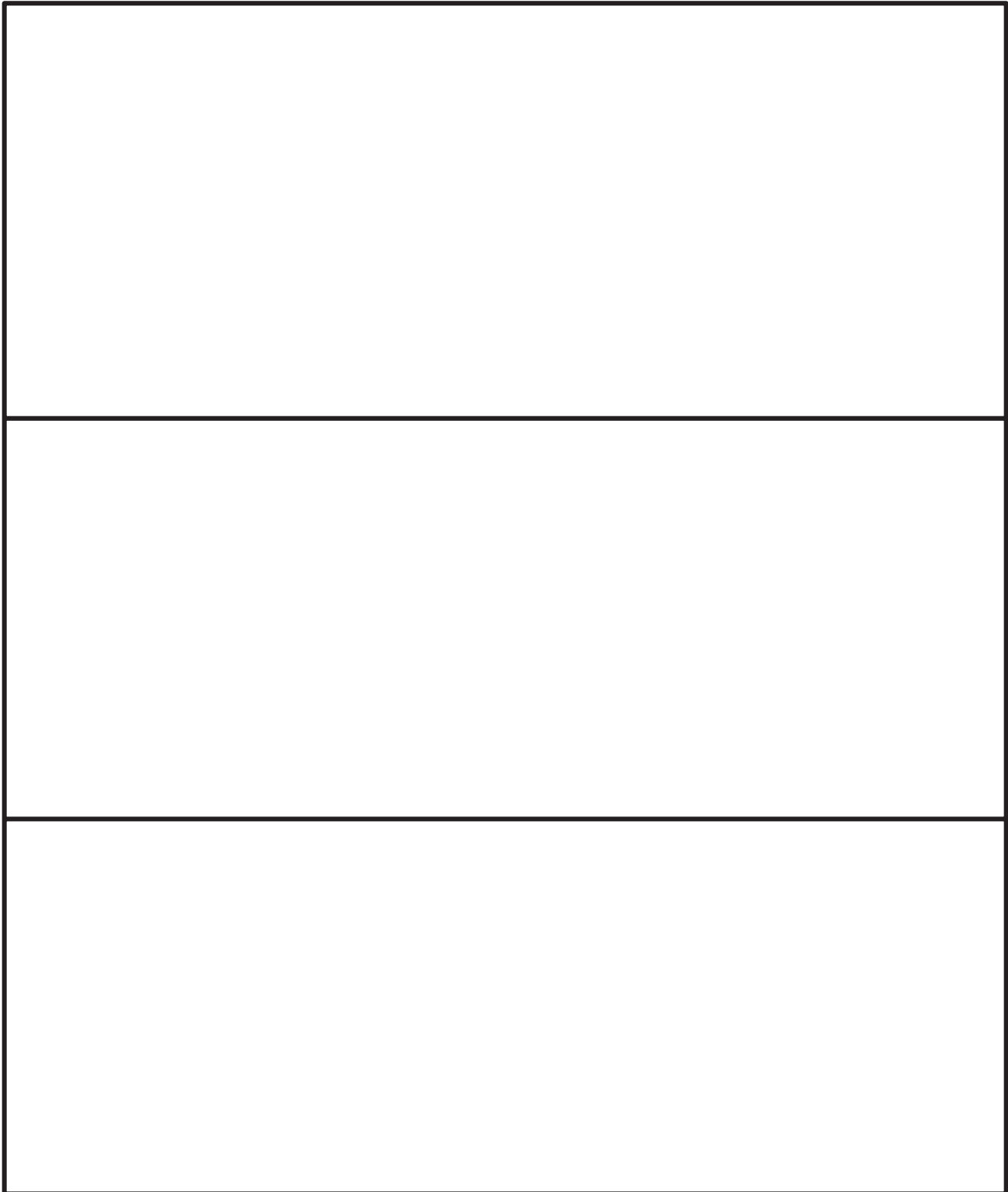

---

unlabeled hundreds place value chart

## Lesson 2

**Objective:** Add and subtract multiples of 100, including counting on to subtract.

### Suggested Lesson Structure

■ Application Problem	(6 minutes)
■ Fluency Practice	(10 minutes)
■ Concept Development	(34 minutes)
■ Student Debrief	(10 minutes)
<b>Total Time</b>	<b>(60 minutes)</b>

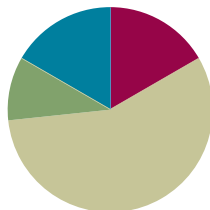

### Application Problem (6 minutes)

Max has 42 marbles in his marble bag after he added 20 marbles at noon. How many marbles did he have before noon?

Note: This problem gives students a chance to apply their new learning and to practice an *add to with start unknown* problem—as in Module 4. Many students will incorrectly say 62 marbles. Encourage them to represent the problem using a number bond if they are struggling. This way, they see the part-whole relationship modeled differently.

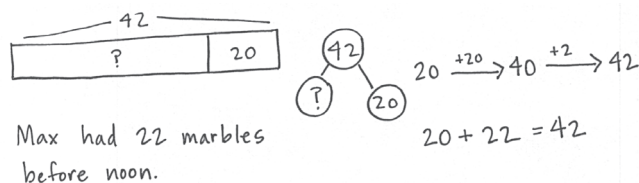

### Fluency Practice (10 minutes)

- Place Value (7 minutes)
- How Many More Hundreds? (3 minutes)

### Place Value (7 minutes)

Materials: (T) Hundreds place value chart (Lesson 1 Template 1) (S) Personal white board, hundreds place value chart (Lesson 1 Template 1)

Note: Practicing place value skills prepares students for adding and subtracting multiples of 100 in today's lesson.

- T: (Project hundreds place value chart.) Show 1 hundred 5 tens 2 ones in chips on a place value chart. Write the number below it.
- S: (Draw 1 hundred 5 tens 2 ones in chips on a place value chart.)

- T: Say the number in unit form.  
 S: 1 hundred 5 tens 2 ones.  
 T: Say the number in unit form using only tens and ones.  
 S: 15 tens 2 ones.  
 T: Say the number in unit form using only hundreds and ones.  
 S: 1 hundred 52 ones.  
 T: Say the number in standard form.  
 S: 152.  
 T: Add 2 hundreds to your chart. How many hundreds do you have now?  
 S: 3 hundreds.  
 T: What is 200 more than 152?  
 S: 352.  
 T: Add 3 hundreds to 352. How many hundreds do you have now?  
 S: 6 hundreds.  
 T: What is 300 more than 352?  
 S: 652.  
 T: Now, subtract 4 hundreds from 652. What is 400 less than 652?  
 S: 252.

Continue with the following possible sequence: + 500, – 100, + 300, and – 900.

### How Many More Hundreds? (3 minutes)

Note: Practice with subtracting multiples of 100 prepares students for today’s lesson.

- T: If I say  $300 - 200$ , you say 100. To say it in a sentence, you say, “100 more than 200 is 300.” Ready?  
 T:  $300 - 200$ .  
 S: 100.  
 T: Say it in a sentence.  
 S: 100 more than 200 is 300.

Continue with the following possible sequence:  $405 - 305$ ,  $801 - 601$ ,  $650 - 350$ ,  $825 - 125$ , and  $999 - 299$ .

### Concept Development (34 minutes)

Materials: (T) Hide Zero cards (Template) (S) Personal white board, 9 each of ones, tens, and hundreds disks

Draw a place value chart on the board. Show 125 using Hide Zero cards.

- T: In Lesson 1 we added and subtracted 1 hundred. Today, let’s add 2 hundreds, then 3 hundreds, and more!

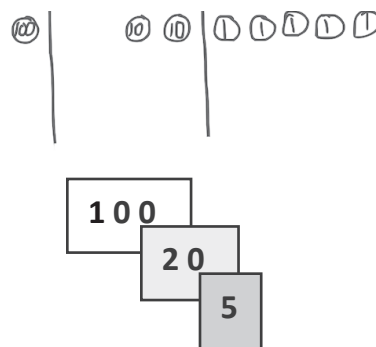

T: How many do you see?

S: 125.

T: (Separate the cards.) Say the number in unit form.

S: 1 hundred 2 tens 5 ones.

T: Show me this number with your place value disks.

S: (Show 1 hundred, 2 tens, and 5 ones on their charts.)

T: (Draw the labeled disks on the board. Change hundreds card to 300, and put cards together.) How much do you see?

S: 325.

T: How can you show this change using your place value disks?

S: Add 2 more hundreds.

T: Now, I am going to add 2 more hundreds. (Draw 2 more hundreds.) You do it, too. Turn and talk: What will happen to the number when I add 2 hundreds?

S: The number in the hundreds place will get bigger by 2. → The number will get bigger by 200. The ones and tens digits will stay the same. → It will be 525.

T: What is  $325 + 200$ ?

S: 525.

T: Say it in unit form.

S: 5 hundreds 2 tens 5 ones!

T: If I asked you to add 3 hundreds to 450, how could you solve that?

S: Count on by a hundred 3 times. → Change the 4 to 7 because 4 hundreds plus 3 hundreds is 7 hundreds. → Add 3 hundreds disks on the place value chart.

T: Let's show that on the board using both simplifying strategies, the arrow way, and number bonds. I know many of you can just do mental math!

T: I can add 3 hundreds using the arrow way, as we did in the last lesson. (Demonstrate and involve students while writing.) I can also break apart the hundreds and tens with a number bond, add the hundreds, and then add the tens. (Demonstrate and involve students while writing.)

T: No matter which way I write it, when I add hundreds to a number, the tens and ones stay the same!

T: Now, it's your turn. On your personal white board, solve  $147 + 200$ . Show me your board when you have an answer.

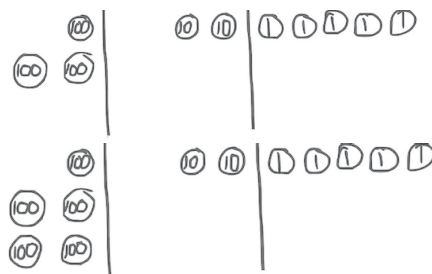

### NOTES ON MULTIPLE MEANS OF ENGAGEMENT:

During the lesson, encourage a student who struggled with adding tens in Module 4 to explain the process of adding hundreds to the class. This helps students solidify their understanding and build confidence. Praise their use of place value language to explain their thinking.

$$450 + 300 \rightarrow 750$$

$$\begin{array}{r} 450 + 300 \\ \swarrow \searrow \\ 400 \quad 50 \end{array}$$

$$\begin{array}{l} 400 + 300 = 700 \\ 700 + 50 = 750 \end{array}$$

Repeat this process, as needed, with the following possible sequence:  $276 + 300$ ,  $382 + 400$ , and  $400 + 516$ .

(Show 725 using Hide Zero cards, and draw disks on the place value chart on the board.)

- T: Now, let's subtract 2 hundreds, then 3 hundreds, and more!
- T: How many do you see?
- S: 725.
- T: Say it in unit form.
- S: 7 hundreds 2 tens 5 ones!
- T: (Replace the 700 card with 500 and erase 2 hundreds from the chart.) How many do you see?
- S: 5 hundreds 2 tens 5 ones.
- T: I am going to subtract 2 more hundreds. Turn and talk: What will happen to the number when I subtract 2 hundreds?
- S: The number in the hundreds place will get smaller by 2. → The number will get smaller by 200. → It will be 325 because 5 hundreds minus 2 hundreds equals 3 hundreds. The other digits stay the same.
- T: (Subtract 2 hundreds.) What is  $525 - 200$ ?
- S: 325.
- T: Say it in unit form.
- S: 3 hundreds 2 tens 5 ones!
- T: Okay, now let's subtract 3 hundreds from 582. Take a moment and work on your personal white board to solve  $582 - 300$ . (Show the work on the board as students work out this first problem using number bonds and the arrow way.)

T: (Model both the number bond and arrow method from their work.) We have an extra simplifying strategy when we are subtracting. We can count up from the part we know.

- T: What is the whole?
- S: 582.
- T: What is the part we know?
- S: 300.
- T: How can we show the missing part with an addition problem?
- S:  $300 + \underline{\quad} = 582$ . →  $\underline{\quad} + 300 = 582$ .

Number bond

$$582 - 300$$

82 500

$$500 - 300 = 200$$

$$200 + 82 = 282$$

I can choose which way works best for me!

The Arrow Way

$$300 \xrightarrow{+100} 400 \xrightarrow{+100} 500 \xrightarrow{+82} 582$$

$$300 + \underline{282} = 582$$

T: We can use the arrow way, counting first by either tens or hundreds. Try it with a partner.

Guide students through this, or let them work independently. Students may start at 300, add 2 hundreds first, and then 82, or add 82 first, and then add 2 hundreds.

Repeat with  $620 - 400$ ,  $541 - 200$ , and  $797 - 300$ .



### NOTES ON MULTIPLE MEANS OF ACTION AND EXPRESSION:

Invite a student to be in charge of the place value chart while the teacher works with the Hide Zero cards, or vice versa.

The number bond's decomposition is one choice for solving the problem that may not work for some students as a solution strategy but is beneficial for all to understand. Students should be encouraged to make connections between different solution strategies and to choose what works best for a given problem or for their way of thinking.



### Problem Set (10 minutes)

Students should do their personal best to complete the Problem Set within the allotted 10 minutes. For some classes, it may be appropriate to modify the assignment by specifying which problems they work on first. Some problems do not specify a method for solving. Students should solve these problems using the RDW approach used for Application Problems.

### Student Debrief (10 minutes)

**Lesson Objective:** Add and subtract multiples of 100, including counting on to subtract.

The Student Debrief is intended to invite reflection and active processing of the total lesson experience.

Invite students to review their solutions for the Problem Set. They should check work by comparing answers with a partner before going over answers as a class. Look for misconceptions or misunderstandings that can be addressed in the Student Debrief. Guide students in a conversation to debrief the Problem Set and process the lesson. Any combination of the questions below may be used to lead the discussion.

- In Problem 1(c),  $400 + 374$ , what happened to 374 when you added 4 hundreds? What happened to the other digits?
- Which strategy did you use to solve the sequence in Problem 1(e)? Why is the arrow way a good choice when you have a missing part or addend?
- If you were using place value disks to show Problem 2(c),  $667 - 500$ , what change would you make on your place value chart? What would stay the same?
- Explain to your partner how you solved the sequence in Problem 2(c). How could you show the missing part with an addition problem? How could you count on from the part you know?
- How was solving Problem 3(b) different from solving Problem 3(c)? Did you add hundreds in both situations? For each problem, did you find the part or whole?

Name Amelia Date \_\_\_\_\_

1. Solve each addition problem using place value strategies. Use the arrow way or mental math, and record your answers. You may use scrap paper if you like.

a. 2 hundreds 4 tens + 3 hundreds = 5 hundreds 4 tens  
 $240 + 300 = 540$

b.  $340 + 300 = 640$      $140 + 500 = 640$      $200 + 440 = 640$

c.  $400 + 374 = 774$      $274 + 500 = 774$      $700 + 236 = 936$

d.  $571 + 300 = 871$      $400 + 349 = 749$      $96 + 600 = 696$

e.  $300 + 562 = 862$      $300 + 483 = 783$      $600 + 126 = 726$

2. Solve each subtraction problem using place value strategies. Use the arrow way or mental math, and record your answers. You may use scrap paper if you like.

a. 6 hundreds 2 ones - 4 hundreds = 2 hundreds 0 tens 2 ones  
 $602 - 400 = 202$

b.  $640 - 200 = 440$      $650 - 300 = 350$      $750 - 400 = 350$

c.  $462 - 200 = 262$      $667 - 500 = 167$      $731 - 400 = 331$

d.  $431 - 300 = 131$      $985 - 400 = 585$      $768 - 700 = 68$

e.  $862 - 200 = 662$      $953 - 300 = 653$      $734 - 500 = 234$

3. Fill in the blanks to make true number sentences. Use place value strategies, number bonds, or the arrow way to solve.

a. 200 more than 389 is 589  
 $389 \xrightarrow{+200} 589$

b. 300 more than 268 is 568.  
 3 hundreds more than 2 hundreds is 5 hundreds

c. 400 less than 867 is 467  
 $8 \text{ hundreds} - 4 \text{ hundreds} = 4 \text{ hundreds}$

d. 700 less than 962 is 262.  
 $900 - 200 = 700$

4. Jessica's lemon tree had 526 lemons. She gave away 300 lemons. How many does she have left? Use the arrow way to solve.

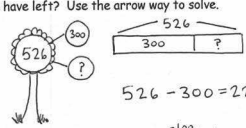

$526 - 300 = 226$

$526 \xrightarrow{-100} 426 \xrightarrow{-100} 326 \xrightarrow{-100} 226$

Jessica has 226 lemons left.

- Explain to your partner which strategies you used to solve Problems 3(c) and (d). Did you use the same strategy for both problems? Can you think of another way to solve these problems?

**Exit Ticket (3 minutes)**

After the Student Debrief, instruct students to complete the Exit Ticket. A review of their work will help with assessing students' understanding of the concepts that were presented in today's lesson and planning more effectively for future lessons. The questions may be read aloud to the students.

Name \_\_\_\_\_

Date \_\_\_\_\_

1. Solve each addition problem using place value strategies. Use the arrow way or mental math, and record your answers. You may use scrap paper if you like.

a. 2 hundreds 4 tens + 3 hundreds = \_\_\_\_\_ hundreds \_\_\_\_\_ tens

$$240 + 300 = \underline{\hspace{2cm}}$$

b.  $340 + 300 = \underline{\hspace{2cm}}$        $140 + 500 = \underline{\hspace{2cm}}$        $200 + 440 = \underline{\hspace{2cm}}$

c.  $400 + 374 = \underline{\hspace{2cm}}$        $274 + 500 = \underline{\hspace{2cm}}$        $700 + 236 = \underline{\hspace{2cm}}$

d.  $571 + \underline{\hspace{2cm}} = 871$        $\underline{\hspace{2cm}} + 349 = 749$        $96 + \underline{\hspace{2cm}} = 696$

e.  $\underline{\hspace{2cm}} + 562 = 862$        $300 + \underline{\hspace{2cm}} = 783$        $600 + \underline{\hspace{2cm}} = 726$

2. Solve each subtraction problem using place value strategies. Use the arrow way or mental math, and record your answers. You may use scrap paper if you like.

a. 6 hundreds 2 ones – 4 hundreds = \_\_\_\_\_ hundreds \_\_\_\_\_ tens \_\_\_\_\_ ones

$$602 - 400 = \underline{\hspace{2cm}}$$

b.  $640 - 200 = \underline{\hspace{2cm}}$        $650 - 300 = \underline{\hspace{2cm}}$        $750 - \underline{\hspace{2cm}} = 350$

c.  $462 - 200 = \underline{\hspace{2cm}}$        $667 - 500 = \underline{\hspace{2cm}}$        $731 - 400 = \underline{\hspace{2cm}}$

d.  $431 - \underline{\hspace{2cm}} = 131$        $985 - \underline{\hspace{2cm}} = 585$        $768 - \underline{\hspace{2cm}} = 68$

e.  $\underline{\hspace{2cm}} - 200 = 662$        $\underline{\hspace{2cm}} - 300 = 653$        $734 - \underline{\hspace{2cm}} = 234$

3. Fill in the blanks to make true number sentences. Use place value strategies, number bonds, or the arrow way to solve.
- a. 200 more than 389 is \_\_\_\_\_.
- b. 300 more than \_\_\_\_\_ is 568.
- c. 400 less than 867 is \_\_\_\_\_.
- d. \_\_\_\_\_ less than 962 is 262.
4. Jessica's lemon tree had 526 lemons. She gave away 300 lemons. How many does she have left? Use the arrow way to solve.

Name \_\_\_\_\_

Date \_\_\_\_\_

Solve using place value strategies. Use the arrow way or mental math, and record your answers. You may use scrap paper if you like.

1.  $760 - 500 = \underline{\quad}$

$880 - 600 = \underline{\quad}$

$990 - \underline{\quad} = 590$

2.  $534 - 334 = \underline{\quad}$

$\underline{\quad} - 500 = 356$

$736 - \underline{\quad} = 136$

Name \_\_\_\_\_

Date \_\_\_\_\_

1. Solve each addition problem using place value strategies. Use the arrow way or mental math, and record your answers. You may use scrap paper if you like.

a. 4 hundreds 5 tens + 2 hundreds = \_\_\_\_\_ hundreds \_\_\_\_\_ tens

$$450 + 200 = \underline{\quad}$$

b.  $220 + 300 = \underline{\quad}$        $230 + 500 = \underline{\quad}$        $200 + 440 = \underline{\quad}$

c.  $400 + 368 = \underline{\quad}$        $386 + 500 = \underline{\quad}$        $700 + 239 = \underline{\quad}$

d.  $119 + \underline{\quad} = 519$        $\underline{\quad} + 272 = 872$        $62 + \underline{\quad} = 562$

2. Solve each subtraction problem using place value strategies. Use the arrow way or mental math, and record your answers. You may use scrap paper if you like.

a. 5 hundreds 8 ones – 3 hundreds = \_\_\_\_\_ hundreds \_\_\_\_\_ tens \_\_\_\_\_ ones

$$508 - 300 = \underline{\quad}$$

b.  $430 - 200 = \underline{\quad}$        $550 - 300 = \underline{\quad}$        $860 - \underline{\quad} = 360$

c.  $628 - 200 = \underline{\quad}$        $718 - 500 = \underline{\quad}$        $836 - 400 = \underline{\quad}$

d.  $553 - \underline{\quad} = 153$        $981 - \underline{\quad} = 381$        $827 - \underline{\quad} = 27$

3. Fill in the blanks to make true number sentences. Use place value strategies, number bonds, or the arrow way to solve.

a. 300 more than 215 is \_\_\_\_\_.

b. 300 more than \_\_\_\_\_ is 668.

c. 500 less than 980 is \_\_\_\_\_.

d. \_\_\_\_\_ less than 987 is 487.

e. 600 \_\_\_\_\_ than 871 is 271.

f. 400 \_\_\_\_\_ than 444 is 844.

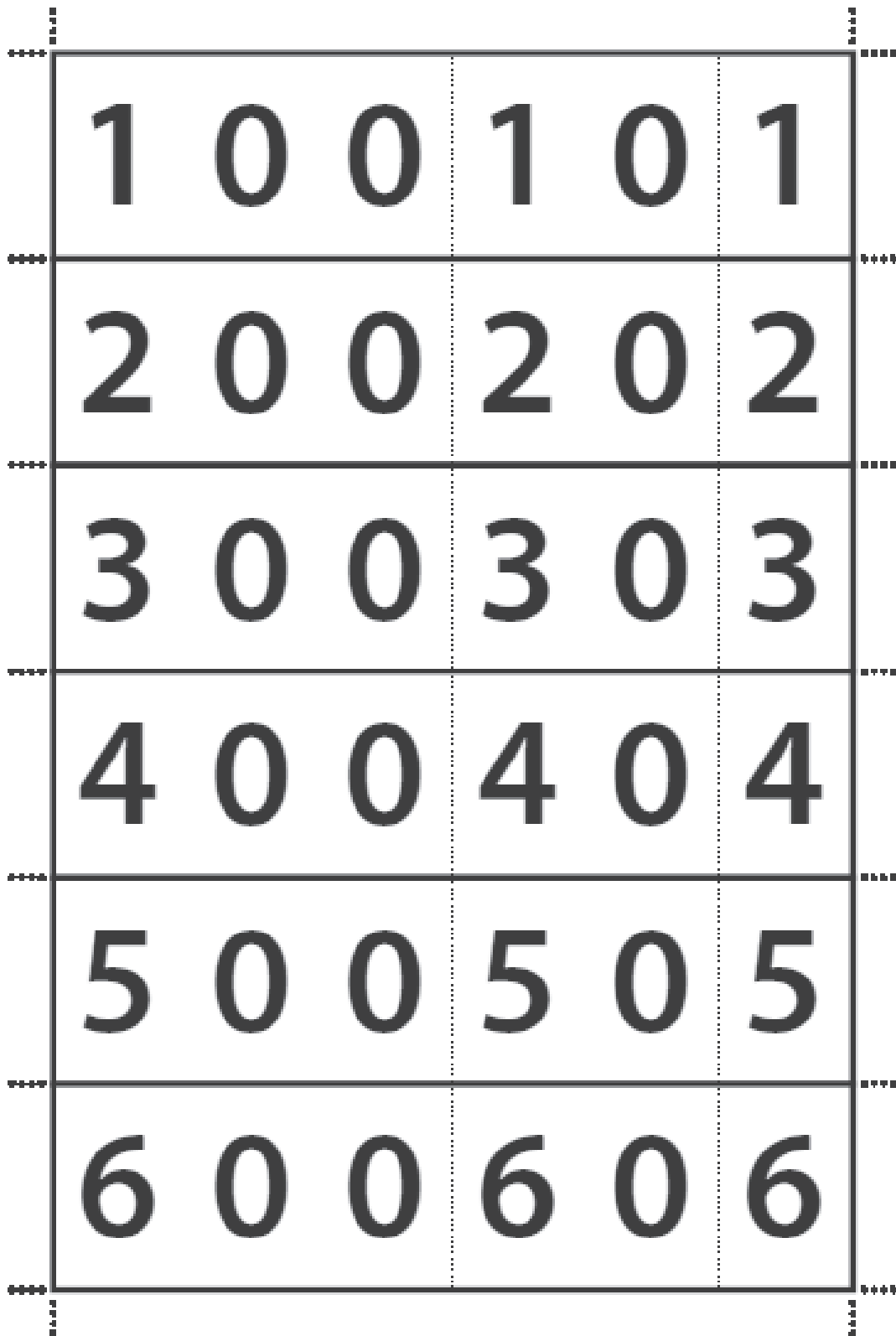

hide zero cards



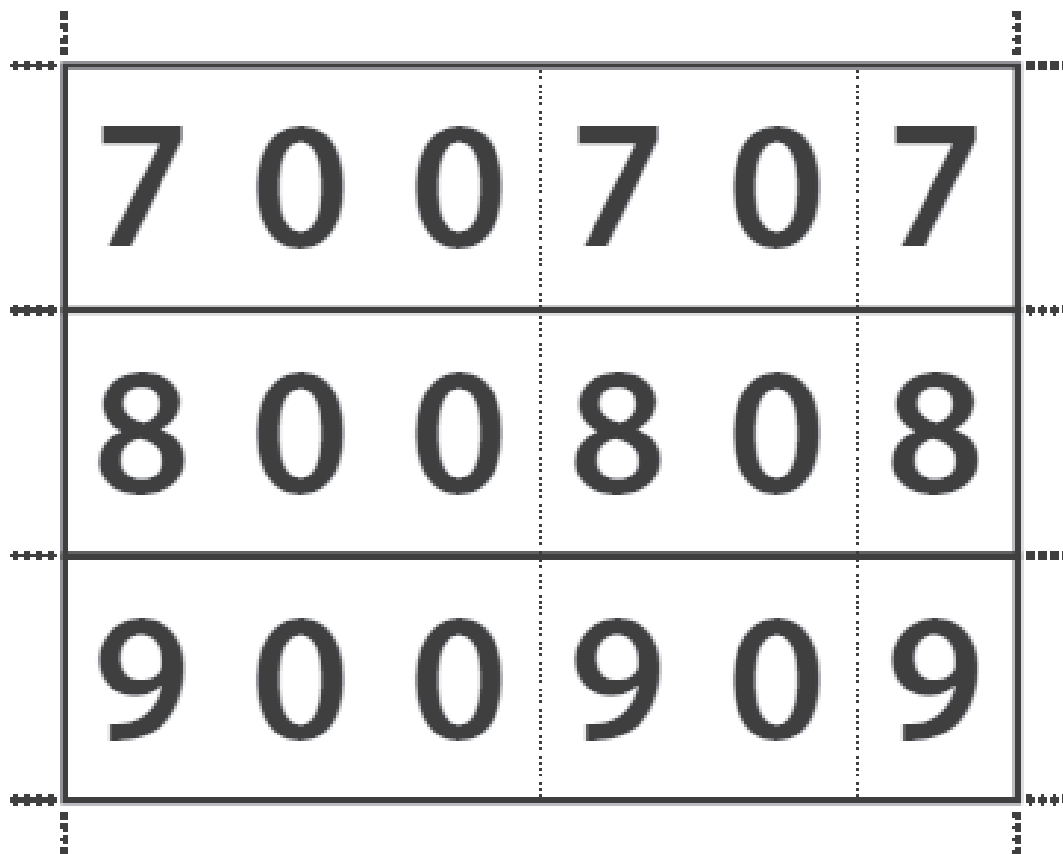

---

hide zero cards

## Lesson 3

Objective: Add multiples of 100 and some tens within 1,000.

### Suggested Lesson Structure

■ Application Problem	(5 minutes)
■ Fluency Practice	(11 minutes)
■ Concept Development	(34 minutes)
■ Student Debrief	(10 minutes)
<b>Total Time</b>	<b>(60 minutes)</b>

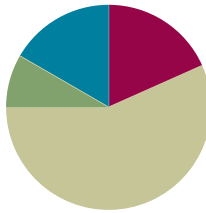

### Application Problem (5 minutes)

A children's library sold 27 donated books. Now, they have 48. How many books were there to begin with?

Note: This problem is a *take from with start unknown*. Because *selling* invites subtraction, the problem may prove to be a challenge for some students. The calculation itself involves using their place value strategies from Module 4, allowing them to choose between using the vertical form, a number bond, or the arrow way.

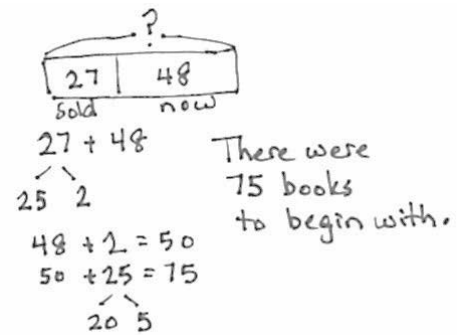

### Fluency Practice (11 minutes)

- How Many More to Make 100? (2 minutes)
- Sprint: Adding Multiples of Ten and Some Ones (9 minutes)

### How Many More to Make 100? (2 minutes)

Note: Students practice mentally making 100.

- T: How many more ones does 8 need to make 10?  
 S: 2 ones.  
 T: Say the addition number sentence.  
 S:  $8 + 2 = 10$ .  
 T: How many more tens does 8 tens need to make 10 tens?  
 S: 2 tens.  
 T: Say the addition number sentence starting with 8 tens.  
 S:  $8 \text{ tens} + 2 \text{ tens} = 10 \text{ tens}$ .

T: How much more does 80 need to make 100?

S: Twenty.

T: Say the addition sentence.

S:  $80 + 20 = 100$ .

Continue with the following sequence:  $16 + 4$ , 16 tens + 4 tens,  $160 + 40$ , and  $28 + 2$ , 28 tens + 2 tens,  $280 + 20$ .

### Sprint: Adding Multiples of Ten and Some Ones (9 minutes)

Materials: (S) Adding Multiples of Ten and Some Ones Sprint

Note: Students review adding multiples of ten and some ones in preparation for today's lesson.

### Concept Development (34 minutes)

Materials: (S) Personal white board

#### Problem 1: $420 + 100$ , $420 + 110$

T: (While speaking, record using the arrow way.)  $420 + 100$  is...?

S: 520.

T:  $420 + 100$  (pause)  $+ 10$  is...?

S: 530.

T: How much did we add in all?

S: 110.

T: Say the complete number sentence for our last problem.

S:  $420 + 110 = 530$ .

T: Turn and talk to your partner about the steps in adding 110 to 420.

S: We first added 1 hundred, then 1 ten. → We chopped 110 into two parts—a hundred and a ten. We added each one to make it easier.

$$420 \xrightarrow{+100} 520$$

$$420 \xrightarrow{+100} 520 \xrightarrow{+10} 530$$

#### Problem 2: $550 + 200$ , $550 + 250$ , $550 + 260$

T: Let's try another. (Record as before.)  
 $550 + 200$  is...?

S: 750.

T:  $550 + 200$  (pause)  $+ 50$  is...?

S: 800.

T: Add another 10. Now, we have...?

S: 810.

$$550 \xrightarrow{+200} 750$$

$$550 \xrightarrow{+200} 750 \xrightarrow{+50} 800$$

$$550 \xrightarrow{+200} 750 \xrightarrow{+50} 800 \xrightarrow{+10} 810$$

T: Talk with your partner. What just happened?

S: We started with 550. We added 200 and then added 50 to make 8 hundred. Then, we added 10 more to get 810. → We added 260 in all, one chunk at a time.

**Problem 3:  $280 + 200$ ,  $280 + 220$ ,  $280 + 230$**

T: (Write 280 on the board.)

T: Add 200. Now, we have...?

S: 480.

T: How much more to get to the next hundred? Talk with a partner.

S: Two tens. → Twenty.

T: Now, we have 500. Let's show this the arrow way. Do what I do on your personal white board. (Draw as shown to the right.)

S: (Write.)

T: (Show the same on the board.) We just added  $280 + 220$ . Let's write this using the arrow way. (Write on the board as shown to the right.)

T: First, we added 200 to 280, and then we added another 20 to compose the new hundred.

T: Now, let's add another 10. Show me on your personal white board.

S: (Add another 10 on personal white board.)

T: What do we have?

S: 510.

T: This is the same as  $280 + 230$ . First, we added 200, then composed a new hundred, and then we added 10 to get 510.

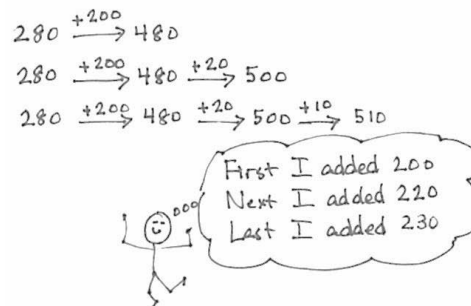

**NOTES ON  
MULTIPLE MEANS  
OF REPRESENTATION:**

For students who struggle to see the change in numbers using the arrow way, use smaller numbers (e.g.,  $180 + 130 = 310$ ) and couple number sentences with models. Return to a concrete manipulative such as bundled straws to show that 18 tens + 10 tens = 28 tens, or 280. Then ask, "How can I compose a new hundred?" Have students model adding 2 more tens and showing the +20 change using the arrow way. Once they have crossed the hundred, adding the remaining ten is simple.

**Problem 4:  $470 + 200$ ,  $470 + 210$ ,  $470 + 230$**

Note: In this part, students record their answers on their personal white board and then turn them over. When most students are ready, say, "Show me." Students hold up their board for a visual check. Then, they erase their board and get ready for the next problem.

T:  $400 + 200$ . Show me.

S: (Show 600.)

T:  $470 + 200$ . Show me.

S: (Show 670.)

- T:  $470 + 210$ ? Talk with a partner first.
- S: I added 7 tens and 1 ten to make 8 tens, and then 4 hundreds and 2 hundreds to make 6 hundreds. That's 680.  $\rightarrow$  I added  $400 + 200$  and then  $70 + 10$ . 600 plus 80 equals 680.  $\rightarrow$  I used the arrow way and added 200 to 470, which is 670, and then added on 10 more to make 680.
- T: Show me.
- S: (Show 680.)
- T:  $470 + 230$ ?
- S: That's like the problem we did before!
- T: Yes! We can find  $470 + 230$  using  $470 + 210$  to help us.
- T: How much more do we need to get from 210 to 230?
- S: 20 more.
- T: What was  $470 + 210$ ?
- S: 680.
- T: 20 more? (Demonstrate as shown to the right.)
- S: 700.
- T: Now, try  $470 + 250$ . Talk with your partner about how you solved it.
- S: I did  $400 + 200$  and then did  $70 + 30$  to get another hundred, and then added the 20 more to get 720.  $\rightarrow$  I added 470 and 200, then 30 more to get 700, and then added the leftover 20 to get 720.  $\rightarrow$  I added  $470 + 230$  like we did before, and then I just added the last 20.



### NOTES ON MULTIPLE MEANS OF ACTION AND EXPRESSION:

Have students talk through their simplifying strategy (i.e., the arrow way) step-by-step to demonstrate their thinking. Before they solve and discuss, post questions such as those below:

- Which addend did you write first?
- Which did you add first, hundreds or tens? Why?
- How did you show making a new hundred: 3 tens plus 7 tens (e.g.,  $530 + 70$ ) or 6 tens plus 4 tens (e.g.,  $860 + 40$ )?
- When you must cross a hundred, what is it helpful to do first?

$470 + 200 \xrightarrow{+20} 670$   
 $470 + 210 \xrightarrow{+200} 670 \xrightarrow{+10} 680$   
 $470 + 230 \xrightarrow{+200} 670 \xrightarrow{+20} 690 \xrightarrow{+10} 700$

470 + 210 is 10 more than 470 + 200  
 470 + 230 is 20 more than 470 + 210

#### Problem 5: $590 + 240$

- T: I notice something interesting about the first number. (Point to 590 on the board.) I wonder if anyone else notices the same thing.
- S: It's close to 600.  $\rightarrow$  It's just 10 away from 600.  $\rightarrow$  I can make the next 100 to help me solve the problem.
- T: Let's try it. You write what I write. (Record as shown below.)

$$590 \xrightarrow{+10} 600 \xrightarrow{+30} 630 \xrightarrow{+200} 830$$

- T: How much do we have left in 240 after using 10?
- S: 230.

Guide students through adding the hundreds and tens the arrow way, asking for their input as you go. When they have worked through this problem, invite them to complete the Problem Set.

### Problem Set (10 minutes)

Students should do their personal best to complete the Problem Set within the allotted 10 minutes. For some classes, it may be appropriate to modify the assignment by specifying which problems they work on first. Some problems do not specify a method for solving. Students should solve these problems using the RDW approach used for Application Problems.

### Student Debrief (10 minutes)

**Lesson Objective:** Add multiples of 100 and some tens within 1,000.

The Student Debrief is intended to invite reflection and active processing of the total lesson experience.

Invite students to review their solutions for the Problem Set. They should check work by comparing answers with a partner before going over answers as a class. Look for misconceptions or misunderstandings that can be addressed in the Student Debrief. Guide students in a conversation to debrief the Problem Set and process the lesson.

Any combination of the questions below may be used to lead the discussion.

- For Problem 1(b), how does knowing  $470 + 400$  help you solve the other problems in that set?
- In Problem 1, what do you notice about the second problem in each set?
- Share with a partner: How did you use the arrow way to solve Problem 1(c),  $650 + 280$ ? How did you decompose 280 to add?
- For Problems 2(a) and (b), how did the first problem in each set help you solve the next two?
- Share with a partner: For Problem 2(c), what was the most efficient way to add  $280 + 260$ ? Did you agree or disagree with your partner? Is there more than one way to solve?
- How is thinking about the make ten strategy helpful when composing a new hundred?

Name Henry Date \_\_\_\_\_

1. Solve each set of problems using the arrow way.

a.	$380 + 200$	$380 \xrightarrow{+100} 480$	$480 \xrightarrow{+100} 580$
	$380 + 220$	$380 \xrightarrow{+100} 480$	$480 \xrightarrow{+20} 500$
	$380 + 230$	$380 \xrightarrow{+100} 480$	$480 \xrightarrow{+20} 500$
			$500 \xrightarrow{+10} 510$
b.	$470 + 400$	$470 \xrightarrow{+100} 570$	$570 \xrightarrow{+100} 670$
	$470 + 430$	$470 \xrightarrow{+100} 570$	$570 \xrightarrow{+30} 600$
	$470 + 450$	$470 \xrightarrow{+100} 570$	$570 \xrightarrow{+30} 600$
			$600 \xrightarrow{+20} 620$
c.	$650 + 200$	$650 \xrightarrow{+200} 850$	
	$650 + 250$	$650 \xrightarrow{+200} 850$	$850 \xrightarrow{+50} 900$
	$650 + 280$	$650 \xrightarrow{+200} 850$	$850 \xrightarrow{+50} 900$
			$900 \xrightarrow{+30} 930$
d.	$430 + 300$	$430 \xrightarrow{+300} 730$	
	$430 + 370$	$430 \xrightarrow{+300} 730$	$730 \xrightarrow{+70} 800$
	$430 + 390$	$430 \xrightarrow{+300} 730$	$730 \xrightarrow{+70} 800$
			$800 \xrightarrow{+20} 820$

2. Solve using the arrow way or mental math. Use scrap paper if needed.

a.	$490 + 200 = 690$	$210 + 490 = 700$	$490 + 220 = 710$
	$490 \xrightarrow{+200} 690$	$200 \xrightarrow{+10} 210$	$490 \xrightarrow{+200} 690$
			$690 \xrightarrow{+10} 700$
			$700 \xrightarrow{+10} 710$
b.	$230 + 700 = 930$	$230 + 710 = 940$	$730 + 230 = 960$
	$200 \xrightarrow{+30} 230$	$200 \xrightarrow{+30} 230$	$730 \xrightarrow{+200} 930$
			$930 \xrightarrow{+30} 960$
c.	$260 + 240 = 500$	$260 + 260 = 520$	$280 + 260 = 540$
	$200 \xrightarrow{+60} 260$	$260 \xrightarrow{+200} 460$	$260 \xrightarrow{+20} 280$
			$460 \xrightarrow{+50} 510$
			$510 \xrightarrow{+30} 540$
d.	$160 + 150 = 310$	$370 + 280 = 650$	$380 + 450 = 830$
	$100 \xrightarrow{+60} 160$	$300 \xrightarrow{+70} 370$	$380 \xrightarrow{+40} 420$
			$420 \xrightarrow{+20} 440$
			$440 \xrightarrow{+20} 460$
			$460 \xrightarrow{+20} 480$
			$480 \xrightarrow{+20} 500$
e.	$430 + 290 = 720$	$660 + 180 = 840$	$370 + 270 = 640$
	$700 \xrightarrow{+30} 730$	$600 \xrightarrow{+60} 660$	$370 \xrightarrow{+20} 390$
			$390 \xrightarrow{+30} 420$
			$420 \xrightarrow{+30} 450$
			$450 \xrightarrow{+30} 480$
			$480 \xrightarrow{+30} 510$
			$510 \xrightarrow{+30} 540$
			$540 \xrightarrow{+30} 570$
			$570 \xrightarrow{+30} 600$
			$600 \xrightarrow{+40} 640$
3. Solve.	a. $66 \text{ tens} + 20 \text{ tens} = 86 \text{ tens}$	b. $66 \text{ tens} + 24 \text{ tens} = 90 \text{ tens}$	
	$66 \xrightarrow{+20} 86$	$66 \xrightarrow{+24} 90$	
	c. $66 \text{ tens} + 27 \text{ tens} = 93 \text{ tens}$	d. $67 \text{ tens} + 28 \text{ tens} = 95 \text{ tens}$	
	$66 \xrightarrow{+27} 93$	$67 \xrightarrow{+28} 95$	
	e. What is the value of 86 tens? <u>860</u>		

**Exit Ticket (3 minutes)**

After the Student Debrief, instruct students to complete the Exit Ticket. A review of their work will help with assessing students' understanding of the concepts that were presented in today's lesson and planning more effectively for future lessons. The questions may be read aloud to the students.

## A

Number Correct: \_\_\_\_\_

## Adding Multiples of Ten and Some Ones

1.	$40 + 3 =$	
2.	$40 + 8 =$	
3.	$40 + 9 =$	
4.	$40 + 10 =$	
5.	$41 + 10 =$	
6.	$42 + 10 =$	
7.	$45 + 10 =$	
8.	$45 + 11 =$	
9.	$45 + 12 =$	
10.	$44 + 12 =$	
11.	$43 + 12 =$	
12.	$43 + 13 =$	
13.	$13 + 43 =$	
14.	$40 + 20 =$	
15.	$41 + 20 =$	
16.	$42 + 20 =$	
17.	$47 + 20 =$	
18.	$47 + 30 =$	
19.	$47 + 40 =$	
20.	$47 + 41 =$	
21.	$47 + 42 =$	
22.	$45 + 42 =$	

23.	$45 + 44 =$	
24.	$44 + 45 =$	
25.	$30 + 20 =$	
26.	$34 + 20 =$	
27.	$34 + 21 =$	
28.	$34 + 25 =$	
29.	$34 + 52 =$	
30.	$50 + 30 =$	
31.	$56 + 30 =$	
32.	$56 + 31 =$	
33.	$56 + 32 =$	
34.	$32 + 56 =$	
35.	$23 + 56 =$	
36.	$24 + 75 =$	
37.	$16 + 73 =$	
38.	$34 + 54 =$	
39.	$62 + 37 =$	
40.	$45 + 34 =$	
41.	$27 + 61 =$	
42.	$16 + 72 =$	
43.	$36 + 42 =$	
44.	$32 + 54 =$	



## B

Number Correct: \_\_\_\_\_

Improvement: \_\_\_\_\_

## Adding Multiples of Ten and Some Ones

1.	$50 + 3 =$	
2.	$50 + 8 =$	
3.	$50 + 9 =$	
4.	$50 + 10 =$	
5.	$51 + 10 =$	
6.	$52 + 10 =$	
7.	$55 + 10 =$	
8.	$55 + 11 =$	
9.	$55 + 12 =$	
10.	$54 + 12 =$	
11.	$53 + 12 =$	
12.	$53 + 13 =$	
13.	$13 + 43 =$	
14.	$50 + 20 =$	
15.	$51 + 20 =$	
16.	$52 + 20 =$	
17.	$57 + 20 =$	
18.	$57 + 30 =$	
19.	$57 + 40 =$	
20.	$57 + 41 =$	
21.	$57 + 42 =$	
22.	$55 + 42 =$	

23.	$55 + 44 =$	
24.	$44 + 55 =$	
25.	$40 + 20 =$	
26.	$44 + 20 =$	
27.	$44 + 21 =$	
28.	$44 + 25 =$	
29.	$44 + 52 =$	
30.	$60 + 30 =$	
31.	$66 + 30 =$	
32.	$66 + 31 =$	
33.	$66 + 32 =$	
34.	$32 + 66 =$	
35.	$23 + 66 =$	
36.	$25 + 74 =$	
37.	$13 + 76 =$	
38.	$43 + 45 =$	
39.	$26 + 73 =$	
40.	$54 + 43 =$	
41.	$72 + 16 =$	
42.	$61 + 27 =$	
43.	$63 + 24 =$	
44.	$32 + 45 =$	

Name \_\_\_\_\_

Date \_\_\_\_\_

1. Solve each set of problems using the arrow way.

a.

$380 + 200$

$380 + 220$

$380 + 230$

b.

$470 + 400$

$470 + 430$

$470 + 450$

c.

$650 + 200$

$650 + 250$

$650 + 280$

d.

$430 + 300$

$430 + 370$

$430 + 390$

2. Solve using the arrow way or mental math. Use scrap paper if needed.

a.  $490 + 200 = \underline{\hspace{2cm}}$        $210 + 490 = \underline{\hspace{2cm}}$        $490 + 220 = \underline{\hspace{2cm}}$

b.  $230 + 700 = \underline{\hspace{2cm}}$        $230 + 710 = \underline{\hspace{2cm}}$        $730 + 230 = \underline{\hspace{2cm}}$

c.  $260 + 240 = \underline{\hspace{2cm}}$        $260 + 260 = \underline{\hspace{2cm}}$        $280 + 260 = \underline{\hspace{2cm}}$

d.  $160 + 150 = \underline{\hspace{2cm}}$        $370 + 280 = \underline{\hspace{2cm}}$        $380 + 450 = \underline{\hspace{2cm}}$

e.  $430 + 290 = \underline{\hspace{2cm}}$        $660 + 180 = \underline{\hspace{2cm}}$        $370 + 270 = \underline{\hspace{2cm}}$

3. Solve.

a.  $66 \text{ tens} + 20 \text{ tens} = \underline{\hspace{2cm}} \text{ tens}$       b.  $66 \text{ tens} + 24 \text{ tens} = \underline{\hspace{2cm}} \text{ tens}$

c.  $66 \text{ tens} + 27 \text{ tens} = \underline{\hspace{2cm}} \text{ tens}$       d.  $67 \text{ tens} + 28 \text{ tens} = \underline{\hspace{2cm}} \text{ tens}$

e. What is the value of 86 tens?  $\underline{\hspace{2cm}}$

Name \_\_\_\_\_

Date \_\_\_\_\_

Solve each set of problems using the arrow way.

1.

$440 + 300$

$360 + 440$

$440 + 380$

2.

$670 + 230$

$680 + 240$

$250 + 660$

Name \_\_\_\_\_

Date \_\_\_\_\_

1. Solve each set of problems using the arrow way.

a.

$260 + 200$

$260 + 240$

$260 + 250$

b.

$320 + 400$

$320 + 480$

$320 + 490$

c.

$550 + 200$

$550 + 250$

$550 + 270$

d.

$230 + 400$

$230 + 470$

$230 + 490$

2. Solve using the arrow way or mental math. Use scrap paper if needed.

a.  $320 + 200 = \underline{\hspace{2cm}}$      $280 + 320 = \underline{\hspace{2cm}}$      $290 + 320 = \underline{\hspace{2cm}}$

b.  $130 + 500 = \underline{\hspace{2cm}}$      $130 + 560 = \underline{\hspace{2cm}}$      $130 + 580 = \underline{\hspace{2cm}}$

c.  $360 + 240 = \underline{\hspace{2cm}}$      $350 + 270 = \underline{\hspace{2cm}}$      $380 + 230 = \underline{\hspace{2cm}}$

d.  $260 + 250 = \underline{\hspace{2cm}}$      $270 + 280 = \underline{\hspace{2cm}}$      $280 + 250 = \underline{\hspace{2cm}}$

e.  $440 + 280 = \underline{\hspace{2cm}}$      $660 + 160 = \underline{\hspace{2cm}}$      $770 + 150 = \underline{\hspace{2cm}}$

3. Solve.

a.  $34 \text{ tens} + 20 \text{ tens} = \underline{\hspace{2cm}} \text{ tens}$     b.  $34 \text{ tens} + 26 \text{ tens} = \underline{\hspace{2cm}} \text{ tens}$

c.  $34 \text{ tens} + 27 \text{ tens} = \underline{\hspace{2cm}} \text{ tens}$     d.  $34 \text{ tens} + 28 \text{ tens} = \underline{\hspace{2cm}} \text{ tens}$

e. What is the value of 62 tens?

## Lesson 4

Objective: Subtract multiples of 100 and some tens within 1,000.

### Suggested Lesson Structure

■ Application Problem	(5 minutes)
■ Fluency Practice	(11 minutes)
■ Concept Development	(34 minutes)
■ Student Debrief	(10 minutes)
<b>Total Time</b>	<b>(60 minutes)</b>

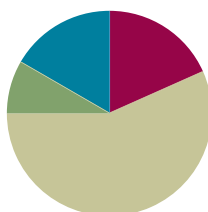

### Application Problem (5 minutes)

Diane needs 65 craft sticks to make a gift box. She only has 48. How many more craft sticks does she need?

Note: Instruct students to approach this *addend unknown* problem using any simplifying strategy or even the vertical form. When students are finished, invite them to share their tape diagrams and solution strategies.

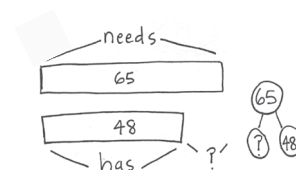

$$48 + \square = 65$$

$$48 \xrightarrow{+2} 50 \xrightarrow{+10} 60 \xrightarrow{+5} 65$$

$$48 + 17 = 65$$

Diane needs 17 more craft sticks.

### Fluency Practice (11 minutes)

- Subtracting Multiples of Hundreds and Tens (2 minutes)
- Sprint: Subtracting Multiples of Ten and Some Ones (9 minutes)

### Subtracting Multiples of Hundreds and Tens (2 minutes)

Note: Students review fluently subtracting multiples of tens and hundreds in preparation for today's lesson.

- T: What is 2 tens less than 130?  
 S: 110.  
 T: Give the subtraction sentence.  
 S:  $130 - 20 = 110$ .  
 T: What is 2 hundreds less than 350?  
 S: 150.  
 T: Give the subtraction sentence.  
 S:  $350 - 200 = 150$ .

Continue with the following sequence: 6 tens less than 150, 3 hundreds less than 550, and 7 tens less than 250.

**Sprint: Subtracting Multiples of Ten and Some Ones (9 minutes)**

Materials: (S) Subtracting Multiples of Ten and Some Ones Sprint

Note: Students fluently subtract multiples of ten and some ones in preparation for today's lesson.

**Concept Development (34 minutes)**

Materials: (S) Personal white board, unlabeled hundreds place value chart (Lesson 1 Template 2), place value disks (7 hundreds, 8 tens)

**Problem 1: 570 – 100, 570 – 110**

T: (While speaking, record using the arrow way.) 570 – 100 is...?

S: 470.

T: 570 – 100 (pause) – 10 is...?

S: 460.

T: How much did we take away in all?

S: 110.

T: Say the complete number sentence for our last problem.

S:  $570 - 110 = 460$ .

T: Turn and talk to your partner about the steps in subtracting 110 from 570.

S: We first took away 1 hundred and then 1 ten. → We made it into two steps: first taking away the hundred and then the ten, to make it easier.

$$570 \xrightarrow{-100} 470$$

$$570 \xrightarrow{-100} 470 \xrightarrow{-10} 460$$

☺ First I subtracted 100.  
Then I subtracted 10.

**Problem 2: 450 – 200, 450 – 210, 450 – 250, 450 – 260**

T: Let's try another. (Record as before.) 450 – 200 is...?

S: 250.

T: 450 – 200 (pause) – 10 is...?

S: 240.

T: Subtract another 40. Now, we have...?

S: 200.

T: Talk with your partner. What just happened?

S: We started with 450. We took away 200 and then 10 to make 240. Then, we took away 40 more to get 200. → We took away 250 in all, one chunk at a time.

T: What if I needed to solve 450 – 260? Could I use 450 – 250 to help me?

S: Yes. → They are 10 apart, so it's easy. → Just subtract 10 more.

T: 450 – 250 – 10 is...?

S: 190

$$450 - 250$$

$$450 \xrightarrow{-200} 250 \xrightarrow{-10} 240 \xrightarrow{-40} 200$$



**Problem 3: 780 – 300, 780 – 380, 780 – 390**

- T: Now, with your place value disks, show me  $780 - 300$ .
- S: (Remove 3 hundreds, showing 480 on their place value charts.)
- T: (Draw 780 on the board. Cross out 3 hundreds to show 480.)
- T: Yes! Now we have 480. How much do we need to take away from 780 to get 400? Turn and talk.
- S: 80 more.  $\rightarrow 380$ .  $\rightarrow$  Take away 300, and then take away 80 more, so 380.
- T: I heard some people say we have to take 380 away. Start with 780, and take away 380 with your place value disks. Do you get 400?
- S: Yes!
- T: (Cross out 8 tens on the board.) I started by taking away 3 hundreds and then 8 tens. I got 400, too.
- T: Now, I want to solve  $780 - 390$ . What do I need to do to solve this? Turn and talk.
- S: Start with  $780 - 380$ , which is 400. Then, take away 10 more.  $\rightarrow$  Rename a hundred to make 10 tens, and take a ten away.  $\rightarrow$  Do one more step to get 10 less than 400, so 390.
- T: I'm going to show this on the board while you do it with your place value disks.
- T: What is  $780 - 390$ ?
- S: 390.
- T: Now, let's show this problem using the arrow way. (Draw on the board as shown above to the right.)

**Problem 4: 400 – 200, 440 – 200, 440 – 240, 440 – 260**

In this part, students record their answers on their personal white boards and then turn them over. When most students are ready, say, "Show me." Students hold up their boards for a visual check. Then, they erase their boards and get ready for the next problem.

**NOTES ON  
MULTIPLE MEANS  
OF ENGAGEMENT:**

As students show  $780 - 390$ , scaffold questioning to guide connections between the place value disks and arrow notation:

- How many hundreds can you subtract first? Which digit changes? Which digits stay the same?
- How many tens do you want to subtract now from 480? Why 80 and not 90?
- Which hundred is closest to 390?
- How much have you subtracted so far? How much is left to subtract from 400?
- What happened to the digits when you subtracted from 400? Why?
- How did you break 390 into smaller parts?

$$780 - 390$$

$$780 \xrightarrow{-300} 480 \xrightarrow{-80} 400 \xrightarrow{-10} 390$$

**NOTES ON  
MULTIPLE MEANS  
OF ACTION AND  
EXPRESSION:**

Some students may struggle with understanding the sequence from  $400 - 200$  to  $440 - 260$ :

- Express each number as tens (e.g.,  $40 - 20$ ,  $44 - 20$ ,  $44 - 24$ ,  $44 - 26$ ).
- Then, calculate using tens without including 44 tens  $- 26$  tens (e.g., "What is 44 tens  $- 24$  tens?").
- Restate the first three problems in standard form.
- Include an easier final question,  $440 - 250$ , emphasizing its relationship to  $440 - 240$ .

T:  $400 - 200$ . Show me.

S: (Show 200.)

T:  $440 - 200$ . Show me.

S: (Show 240.)

T:  $440 - 240$ . Show me.

S: (Show 200.)

T:  $440 - 260$ ? Talk with a partner.

S: I used  $440 - 240$  and took away 20 more to get 180.  $\rightarrow$  I did  $440$  minus  $200$ . Then, I took away  $40$  more to make  $200$ , and then  $20$  more.  $\rightarrow$  I took  $200$  away, then  $20$  and  $20$  and  $20$ .

T: Let's see how we might draw that the arrow way. (Draw as shown at the top right.)

T: Now, try  $620 - 430$ . Draw it the arrow way.

$$440 \xrightarrow{-20} 420 \xrightarrow{-20} 400 \xrightarrow{-20} 380 \xrightarrow{-20} 180$$

$$440 \xrightarrow{-200} 240 \xrightarrow{-40} 200 \xrightarrow{-20} 180$$

$$440 \xrightarrow{-240} 200 \xrightarrow{-20} 180$$

Check students' work on their personal white boards, and invite several students to share their work on the board.

### Problem Set (10 minutes)

Students should do their personal best to complete the Problem Set within the allotted 10 minutes. For some classes, it may be appropriate to modify the assignment by specifying which problems they work on first. Some problems do not specify a method for solving. Students should solve these problems using the RDW approach used for Application Problems.

### Student Debrief (10 minutes)

**Lesson Objective:** Subtract multiples of 100 and some tens within 1,000.

The Student Debrief is intended to invite reflection and active processing of the total lesson experience.

Invite students to review their solutions for the Problem Set. They should check work by comparing answers with a partner before going over answers as a class. Look for misconceptions or misunderstandings that can be addressed in the Student Debrief. Guide students in a conversation to debrief the Problem Set and process the lesson.

Any combination of the questions below may be used to lead the discussion.

- For Problem 1(a), how does knowing  $570 - 200$  help you solve the other problems in that set?
- For Problem 1(b), what makes solving  $760 - 480$  more challenging? How did you use what you know about place value to subtract?

Name	Emilia	Date	
1. Solve using the arrow way.			
a.	$570 - 200 \quad 570 \xrightarrow{-200} 370$ $570 - 270 \quad 570 \xrightarrow{-200} 370 \xrightarrow{-70} 300$ $570 - 290 \quad 570 \xrightarrow{-200} 370 \xrightarrow{-70} 300 \xrightarrow{-20} 280$		
b.	$760 - 400 \quad 760 \xrightarrow{-400} 360$ $760 - 460 \quad 760 \xrightarrow{-400} 360 \xrightarrow{-60} 300$ $760 - 480 \quad 760 \xrightarrow{-400} 360 \xrightarrow{-60} 300 \xrightarrow{-20} 280$		
c.	$950 - 500 \quad 950 \xrightarrow{-500} 450$ $950 - 550 \quad 950 \xrightarrow{-500} 450 \xrightarrow{-50} 400$ $950 - 580 \quad 950 \xrightarrow{-500} 450 \xrightarrow{-50} 400 \xrightarrow{-30} 370$		
d.	$820 - 320 \quad 820 \xrightarrow{-300} 520 \xrightarrow{-20} 500$ $820 - 360 \quad 820 \xrightarrow{-300} 520 \xrightarrow{-20} 500 \xrightarrow{-40} 460$ $820 - 390 \quad 820 \xrightarrow{-300} 520 \xrightarrow{-20} 500 \xrightarrow{-70} 430$		

- Share with a partner: How did using the arrow way help you solve Problem 1(c),  $950 - 580$ ? What careful observations can you make about the numbers you subtracted? Why did you choose to subtract 50, then 30? Why didn't you just subtract 80?
- Look carefully at the numbers in Problem 1(d). What pattern do you notice within the numbers you subtracted from 820? How did this affect the arrow way? Could you have solved these mentally?
- For Problem 2(d),  $740 - 690$ , Terri solved the problem using an equal sign instead of arrows:  $740 - 600 = 140 - 40 = 100 - 50 = 50$ . Is her answer correct? Is her equation correct? Why can't she use an equal sign to show the change?
- How does using the arrow way help us when there are not enough tens from which to subtract (e.g.,  $740 - 650$ )? How did you decompose one part to subtract more easily?

2. Solve using the arrow way or mental math. Use scrap paper if needed.

a.	$530 - 400 = 130$	$530 - 430 = 100$	$530 - 460 = 70$
	5 hundreds - 4 hundreds = 1 hundred	$530 \xrightarrow{-400} 130 \xrightarrow{-30} 100 \xrightarrow{-30} 70$	
b.	$950 - 550 = 400$	$950 - 660 = 290$	$950 - 680 = 270$
	$900 - 500$ $50 - 50$	$950 \xrightarrow{-600} 350 \xrightarrow{-50} 300 \xrightarrow{-10} 290$	$950 \xrightarrow{-600} 350 \xrightarrow{-30} 320 \xrightarrow{-30} 290$
c.	$640 - 240 = 400$	$640 - 250 = 390$	$640 - 290 = 350$
	$600 - 200$ $40 - 40$	$640 \xrightarrow{-200} 440 \xrightarrow{-10} 430 \xrightarrow{-40} 390$	$650 - 300 = 350$
d.	$740 - 440 = 300$	$740 - 650 = 90$	$740 - 690 = 50$
	$700 - 400$ $40 - 40$	$740 \xrightarrow{-600} 140 \xrightarrow{-50} 90$	$750 - 700 = 50$

3. Solve.

a. 88 tens - 20 tens = <u>68 tens</u>	b. 88 tens - 28 tens = <u>60 tens</u>
$88 \xrightarrow{-20} 68$	$88 \xrightarrow{-20} 68 \xrightarrow{-8} 60$
c. 88 tens - 29 tens = <u>59 tens</u>	d. 84 tens - 28 tens = <u>56 tens</u>
$88 \xrightarrow{-30} 58 \xrightarrow{-1} 59$	$84 \xrightarrow{-20} 64 \xrightarrow{-4} 60 \xrightarrow{-4} 56$
e. What is the value of 60 tens? <u>600</u>	
f. What is the value of 56 tens? <u>560</u>	

### Exit Ticket (3 minutes)

After the Student Debrief, instruct students to complete the Exit Ticket. A review of their work will help with assessing students' understanding of the concepts that were presented in today's lesson and planning more effectively for future lessons. The questions may be read aloud to the students.

A

Number Correct: \_\_\_\_\_

## Subtracting Multiples of Ten and Some Ones

1.	$33 - 22 =$	
2.	$44 - 33 =$	
3.	$55 - 44 =$	
4.	$99 - 88 =$	
5.	$33 - 11 =$	
6.	$44 - 22 =$	
7.	$55 - 33 =$	
8.	$88 - 22 =$	
9.	$66 - 22 =$	
10.	$43 - 11 =$	
11.	$34 - 11 =$	
12.	$45 - 11 =$	
13.	$46 - 12 =$	
14.	$55 - 12 =$	
15.	$54 - 12 =$	
16.	$55 - 21 =$	
17.	$64 - 21 =$	
18.	$63 - 21 =$	
19.	$45 - 21 =$	
20.	$34 - 12 =$	
21.	$43 - 21 =$	
22.	$54 - 32 =$	

23.	$99 - 32 =$	
24.	$86 - 32 =$	
25.	$79 - 32 =$	
26.	$79 - 23 =$	
27.	$68 - 13 =$	
28.	$69 - 23 =$	
29.	$89 - 14 =$	
30.	$77 - 12 =$	
31.	$57 - 12 =$	
32.	$77 - 32 =$	
33.	$99 - 36 =$	
34.	$88 - 25 =$	
35.	$89 - 36 =$	
36.	$98 - 16 =$	
37.	$78 - 26 =$	
38.	$99 - 37 =$	
39.	$89 - 38 =$	
40.	$59 - 28 =$	
41.	$99 - 58 =$	
42.	$99 - 45 =$	
43.	$78 - 43 =$	
44.	$98 - 73 =$	

**B**

Number Correct: \_\_\_\_\_

Improvement: \_\_\_\_\_

## Subtracting Multiples of Ten and Some Ones

1.	$33 - 11 =$	
2.	$44 - 11 =$	
3.	$55 - 11 =$	
4.	$88 - 11 =$	
5.	$33 - 22 =$	
6.	$44 - 22 =$	
7.	$55 - 22 =$	
8.	$99 - 22 =$	
9.	$77 - 22 =$	
10.	$34 - 11 =$	
11.	$43 - 11 =$	
12.	$54 - 11 =$	
13.	$55 - 12 =$	
14.	$46 - 12 =$	
15.	$44 - 12 =$	
16.	$64 - 21 =$	
17.	$55 - 21 =$	
18.	$53 - 21 =$	
19.	$44 - 21 =$	
20.	$34 - 22 =$	
21.	$43 - 22 =$	
22.	$54 - 22 =$	

23.	$99 - 42 =$	
24.	$79 - 32 =$	
25.	$89 - 52 =$	
26.	$99 - 23 =$	
27.	$79 - 13 =$	
28.	$79 - 23 =$	
29.	$99 - 14 =$	
30.	$87 - 12 =$	
31.	$77 - 12 =$	
32.	$87 - 32 =$	
33.	$99 - 36 =$	
34.	$78 - 25 =$	
35.	$79 - 36 =$	
36.	$88 - 16 =$	
37.	$88 - 26 =$	
38.	$89 - 37 =$	
39.	$99 - 38 =$	
40.	$69 - 28 =$	
41.	$89 - 58 =$	
42.	$99 - 45 =$	
43.	$68 - 43 =$	
44.	$98 - 72 =$	

Name \_\_\_\_\_

Date \_\_\_\_\_

1. Solve using the arrow way.

a.

$570 - 200$

$570 - 270$

$570 - 290$

b.

$760 - 400$

$760 - 460$

$760 - 480$

c.

$950 - 500$

$950 - 550$

$950 - 580$

d.

$820 - 320$

$820 - 360$

$820 - 390$

2. Solve using the arrow way or mental math. Use scrap paper if needed.

a.	$530 - 400 = \underline{\hspace{2cm}}$	$530 - 430 = \underline{\hspace{2cm}}$	$530 - 460 = \underline{\hspace{2cm}}$
b.	$950 - 550 = \underline{\hspace{2cm}}$	$950 - 660 = \underline{\hspace{2cm}}$	$950 - 680 = \underline{\hspace{2cm}}$
c.	$640 - 240 = \underline{\hspace{2cm}}$	$640 - 250 = \underline{\hspace{2cm}}$	$640 - 290 = \underline{\hspace{2cm}}$
d.	$740 - 440 = \underline{\hspace{2cm}}$	$740 - 650 = \underline{\hspace{2cm}}$	$740 - 690 = \underline{\hspace{2cm}}$

3. Solve.

a.  $88 \text{ tens} - 20 \text{ tens} = \underline{\hspace{2cm}}$       b.  $88 \text{ tens} - 28 \text{ tens} = \underline{\hspace{2cm}}$

c.  $88 \text{ tens} - 29 \text{ tens} = \underline{\hspace{2cm}}$       d.  $84 \text{ tens} - 28 \text{ tens} = \underline{\hspace{2cm}}$

e. What is the value of 60 tens?  $\underline{\hspace{2cm}}$

f. What is the value of 56 tens?  $\underline{\hspace{2cm}}$

Name \_\_\_\_\_

Date \_\_\_\_\_

1. Solve using a simplifying strategy. Show your work if needed.

$830 - 530 = \underline{\hspace{2cm}}$

$830 - 750 = \underline{\hspace{2cm}}$

$830 - 780 = \underline{\hspace{2cm}}$

2. Solve.

a.  $67 \text{ tens} - 30 \text{ tens} = \underline{\hspace{2cm}}$  tens. The value is  $\underline{\hspace{2cm}}$ .

b.  $67 \text{ tens} - 37 \text{ tens} = \underline{\hspace{2cm}}$  tens. The value is  $\underline{\hspace{2cm}}$ .

c.  $67 \text{ tens} - 39 \text{ tens} = \underline{\hspace{2cm}}$  tens. The value is  $\underline{\hspace{2cm}}$ .



Name \_\_\_\_\_

Date \_\_\_\_\_

1. Solve using the arrow way.

a.

$430 - 200$

$430 - 230$

$430 - 240$

b.

$570 - 300$

$570 - 370$

$570 - 390$

c.

$750 - 400$

$750 - 450$

$750 - 480$

d.

$940 - 330$

$940 - 360$

$940 - 480$

2. Solve using the arrow way or mental math. Use scrap paper if needed.

a.

$$330 - 200 = \underline{\hspace{2cm}} \quad 330 - 230 = \underline{\hspace{2cm}} \quad 330 - 260 = \underline{\hspace{2cm}}$$

b.

$$440 - 240 = \underline{\hspace{2cm}} \quad 440 - 260 = \underline{\hspace{2cm}} \quad 440 - 290 = \underline{\hspace{2cm}}$$

c.

$$860 - 560 = \underline{\hspace{2cm}} \quad 860 - 570 = \underline{\hspace{2cm}} \quad 860 - 590 = \underline{\hspace{2cm}}$$

d.

$$970 - 470 = \underline{\hspace{2cm}} \quad 970 - 480 = \underline{\hspace{2cm}} \quad 970 - 490 = \underline{\hspace{2cm}}$$

3. Solve.

a.  $66 \text{ tens} - 30 \text{ tens} = \underline{\hspace{2cm}}$       b.  $66 \text{ tens} - 36 \text{ tens} = \underline{\hspace{2cm}}$

c.  $66 \text{ tens} - 38 \text{ tens} = \underline{\hspace{2cm}}$       d.  $67 \text{ tens} - 39 \text{ tens} = \underline{\hspace{2cm}}$

e. What is the value of 28 tens?  $\underline{\hspace{2cm}}$

f. What is the value of 36 tens?  $\underline{\hspace{2cm}}$

## Lesson 5

**Objective:** Use the associative property to make a hundred in one addend.

### Suggested Lesson Structure

■ Application Problem	(6 minutes)
■ Fluency Practice	(10 minutes)
■ Concept Development	(34 minutes)
■ Student Debrief	(10 minutes)
<b>Total Time</b>	<b>(60 minutes)</b>

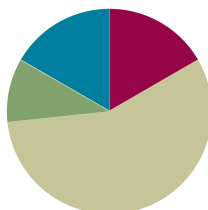

### Application Problem (6 minutes)

Jenny had 39 collectible cards in her collection. Tammy gave her 36 more. How many collectible cards does Jenny have now?

Note: This problem is designed to provide a real life context for the skills students have learned in previous lessons. Invite students to solve this problem using number bonds or any other simplifying strategy they have learned. After solving the problem, have students share their strategies with a partner.

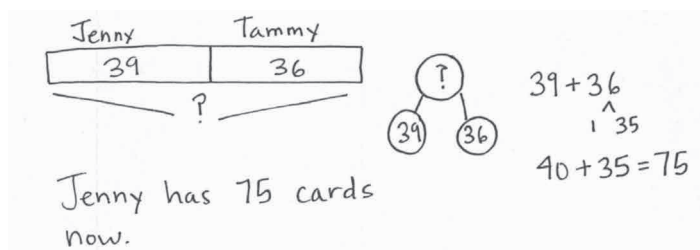

### Fluency Practice (10 minutes)

- Making the Next Hundred (4 minutes)
- Making the Next Hundred to Add (6 minutes)

### Making the Next Hundred (4 minutes)

Note: This fluency activity reviews foundations that lead into today's lesson.

T: (Post  $170 + \underline{\quad} = 200$  on the board.) Let's find missing parts to make the next hundred. I say 170, you say 30. Ready? 170.

S: 30.

T: Give the number sentence.

S:  $170 + 30 = 200$ .

Continue with the following possible sequence: 190, 160, 260, 270, 370, 380, 580, 620, 720, 740, 940, 194, 196, 216, 214, and 224.

**Making the Next Hundred to Add (6 minutes)**

Note: This fluency activity reviews foundations that lead into today’s lesson.

T: When I say 9 tens + 4 tens, you say 10 tens + 3 tens. Ready?

9 tens + 4 tens.

S: 10 tens + 3 tens.

T: Answer in standard form?

S: 130.

T:  $90 + 40$ .

S: 130.

Post on board:

$$90 + 40 = \underline{\quad}$$

$$\begin{array}{r} \wedge \\ 10 \quad 30 \end{array}$$

$$90 + 10 = 100$$

$$100 + 30 = 130$$

Continue with the following possible sequence: 19 tens + 4 tens, 29 tens + 4 tens, 29 tens + 14 tens, 9 tens + 6 tens, 19 tens + 6 tens, 19 tens + 16 tens, 29 tens + 16 tens, 8 tens + 3 tens, 18 tens + 3 tens, 18 tens + 13 tens, 28 tens + 13 tens, 8 tens + 5 tens, 18 tens + 15 tens, and 28 tens + 15 tens.

**Concept Development (34 minutes)**

Materials: (S) Personal white board

**Part 1: 17 + 13, 17 tens + 13 tens, 170 + 130, 170 + 40**

T: What is  $17 + 12$ ?

S: 29.

T: What is  $17 + 13$ ?

S: 30.

T: That was fast! How did you know?

S: I added 1 more to  $17 + 12$ .  $\rightarrow$  13 is 1 more than 12, so the answer had to be 1 more than 29.

T: How many tens equal 17 tens plus 13 tens?

S: 30 tens.

T: What is the value of 30 tens?

S: 300.

T: What is  $170 + 130$ ?

S: 300.

T: What happened when we added those numbers? Turn and talk.

S: We made a new hundred, just like when we added 17 to 13 and made a new ten.  $\rightarrow$  We composed a new hundred.  $\rightarrow$  Instead of 30 ones, we have 30 tens. It’s just like  $17 + 13$  except that the place value is different.

T: What is  $17 + 14$ ? Write it on your personal white board, and turn it over, so I know when you’re ready.

T: (Wait until students are ready.) Show me!

S: (Show 31.)

- T: How many tens equal 17 tens plus 14 tens?  
 S: 31 tens!  
 T:  $170 + 140$ ?  
 S: 310.  
 T: Talk with your partner. How did you know?  
 S: 17 tens plus 14 tens is just like  $17 + 14$ , only in tens, so the answer is similar but in tens.  $\rightarrow 170 + 140$  is 10 more than  $170 + 130$ , so the answer has to be 10 more.  $\rightarrow$  Since  $170 + 130$  was 30 tens, I knew that  $170 + 140$  had to be 31 tens. It's 1 more ten.

Extend to 17 tens + 15 tens, and continue until students are comfortable with the concept.

**Part 2: Add multiples of 10 by making a hundred.**

- T: In the past, we've used number bonds to make the next ten. Let's do it here, too, to make our adding easier when we have hundreds.  
 T: (Write  $190 + 120$  on the board.) Is one of these numbers close to the next hundred?  
 S: Yes!  
 T: Which one?  
 S: 190.  
 T: What is it close to?  
 S: 200.  
 T: How many more do we need to make 200?  
 S: 10 more!  
 T: Where can we get 10 more?  
 S: From the 120.  
 T: Great idea! Let's break apart 120 into 110 and 10. Now, we can add the 10 from 120 to the 190. And we know that 190 plus 10 equals 200. (Show number bond on the board.)  
 T: What is our new addition problem? (Point to corresponding parts of the number bond.)  
 S:  $200 + 110$ .  
 T: Talk with a partner. What does this equal?  
 S: 310.  $\rightarrow$  I did  $200 + 100$  and added 10, so 310.  $\rightarrow$  I remembered what we did with tens, so I thought of  $20 + 11$ , which is 31, and 31 tens equals 310.  
 T: I heard someone say she remembered what she did with the tens. Great! When we have a zero in the ones place, we can think of it as tens.  
 T: How can we prove that  $200 + 110$  is the same as  $190 + 120$ ? Turn and talk.



**NOTES ON  
 MULTIPLE MEANS  
 OF ACTION AND  
 EXPRESSION:**

For students working above grade level, ask for alternative addition and subtraction number sentences that would have the same total (e.g., 32 tens or 320). Include number sentences with three addends.

- $\underline{\quad} + \underline{\quad} = 32$  tens
- $32$  tens  $- \underline{\quad} = \underline{\quad}$
- $\underline{\quad} + \underline{\quad} + \underline{\quad} = 320$

$$\begin{array}{r}
 190 + 120 \\
 \quad \swarrow \searrow \\
 \quad 10 \quad 110 \\
 190 + 10 = 200 \\
 200 + 110 = 310
 \end{array}$$



**NOTES ON  
 MULTIPLE MEANS  
 OF REPRESENTATION:**

For students who have trouble seeing that the two expressions,  $190 + 120$  and  $200 + 110$ , are equivalent, show compensation using manipulatives, such as place value disks.

- S: I can add 100 to 190 and get 290, and then count 20 more by tens. So, that's 300, 310. → I can show both the arrow way, first adding hundreds, then tens. → I just know that since 190 is 10 less than 200, the other part has to be 10 more than 110. Then, the total will be equal. → I did it by using vertical form, and I got the same answer.

Have students solve the following problems on their personal white boards with a partner using number bonds:  $190 + 160$ ,  $430 + 180$ , and  $370 + 240$ .

**Part 3: Add three-digit numbers by making a hundred.**

- T: So far, we've only been working with numbers that have zero in the ones place. Let's try something different now. (Write  $199 + 25$  on the board.)
- T: What hundred is close to 199?
- S: 200.
- T: How far away is it?
- S: 1 away!
- T: Let's try decomposing 25 into 24 and 1. We can add the 1 from 25 to the 199. We know that 199 plus 1 equals 200. (Draw number bond.) What is our new addition problem?
- S:  $200 + 24$ .
- T: And, what is the total?
- S: 224.
- T: Let's try another example. (Write  $295 + 78$  on the board.)
- T: I see one number that is close to some hundreds. Which number is that?
- S: 295.
- T: How far away is it?
- S: 5 away!
- T: Talk with a partner. How would you use a number bond to make a new, simpler expression?
- S: I could make 295 into 300 and have 73 left over. → I break 78 into 5 and 73, and then I give the 5 to 295, so  $300 + 73$ . → I get 300 and 73.
- T: (After student conversation, choose a volunteer to show the number bond and new expression on the board.) What is  $300 + 73$ ?
- S: 373.
- T: Now, let's try one that has hundreds in both addends. (Write  $535 + 397$  on the board.)
- T: Which number is closer to the next hundred?
- S: 397.
- T: With a partner, write the number bond and new addition problem. Then, solve it.
- S: I made  $532 + 400$ , so 932. → 397 is 3 away from 400, so I need to move 3 from the 535 to the 397.  $400 + 532 = 932$ . → Since I added 3 to 397, I had to take away 3 from 535. Now, it's easy to add 4 hundreds onto 532.

$$\begin{array}{r}
 199 + 25 \\
 \quad \swarrow \searrow \\
 \quad 1 \quad 24 \\
 199 + 1 = 200 \\
 200 + 24 = 224
 \end{array}$$

Have students solve these problems on their personal white boards with a partner using number bonds:  $299 + 22$ ,  $495 + 30$ , and  $527 + 296$ . As they complete the problems, they may begin work on the Problem Set.



- What connections can you make between the number bond strategy and the arrow way? What is the goal of these strategies?

### Exit Ticket (3 minutes)

After the Student Debrief, instruct students to complete the Exit Ticket. A review of their work will help with assessing students' understanding of the concepts that were presented in today's lesson and planning more effectively for future lessons. The questions may be read aloud to the students.

$$\begin{array}{r} \text{d. } 440 + 280 \\ \phantom{440 + 280} \nearrow 220 \\ \phantom{440 + 280} \nwarrow 60 \end{array}$$

$$\underline{500 + 220 = 720}$$

$$\begin{array}{r} \text{e. } 199 + 86 \\ \phantom{199 + 86} \nearrow 85 \\ \phantom{199 + 86} \nwarrow 1 \end{array}$$

$$\underline{200 + 85 = 285}$$

$$\begin{array}{r} \text{f. } 298 + 57 \\ \phantom{298 + 57} \nearrow 55 \\ \phantom{298 + 57} \nwarrow 2 \end{array}$$

$$\underline{300 + 55 = 355}$$

$$\begin{array}{r} \text{g. } 425 + 397 \\ \phantom{425 + 397} \nearrow 3 \\ \phantom{425 + 397} \nwarrow 422 \end{array}$$

$$\underline{422 + 400 = 822}$$



Name \_\_\_\_\_

Date \_\_\_\_\_

1. Solve.

a. 30 tens = \_\_\_\_\_

b. 43 tens = \_\_\_\_\_

c. 18 tens + 12 tens = \_\_\_\_\_ tens

d. 18 tens + 13 tens = \_\_\_\_\_ tens

e. 24 tens + 19 tens = \_\_\_\_\_ tens

f. 25 tens + 29 tens = \_\_\_\_\_ tens

2. Add by drawing a number bond to make a hundred. Write the simplified equation and solve.

a.  $190 + 130$



\_\_\_\_\_  $200 + 120$  \_\_\_\_\_ = \_\_\_\_\_

b.  $260 + 190$

\_\_\_\_\_ = \_\_\_\_\_

c.  $330 + 180$

\_\_\_\_\_ = \_\_\_\_\_

d.  $440 + 280$

$$\underline{\hspace{2cm}} = \underline{\hspace{2cm}}$$

e.  $199 + 86$

$$\underline{\hspace{2cm}} = \underline{\hspace{2cm}}$$

f.  $298 + 57$

$$\underline{\hspace{2cm}} = \underline{\hspace{2cm}}$$

g.  $425 + 397$

$$\underline{\hspace{2cm}} = \underline{\hspace{2cm}}$$

Name \_\_\_\_\_

Date \_\_\_\_\_

1. Add by drawing a number bond to make a hundred. Write the simplified equation and solve.

a.  $390 + 210$

$$\underline{\hspace{2cm}} = \underline{\hspace{2cm}}$$

b.  $798 + 57$

$$\underline{\hspace{2cm}} = \underline{\hspace{2cm}}$$

2. Solve.

$$53 \text{ tens} + 38 \text{ tens} = \underline{\hspace{2cm}}$$

Name \_\_\_\_\_

Date \_\_\_\_\_

1. Solve.

a. 32 tens = \_\_\_\_\_

b. 52 tens = \_\_\_\_\_

c. 19 tens + 11 tens = \_\_\_\_\_ tens

d. 19 tens + 13 tens = \_\_\_\_\_ tens

e. 28 tens + 23 tens = \_\_\_\_\_ tens

f. 28 tens + 24 tens = \_\_\_\_\_ tens

2. Add by drawing a number bond to make a hundred. Write the simplified equation and solve.

a.  $90 + 180$



$$\underline{100 + 170} = \underline{\hspace{2cm}}$$

b.  $190 + 460$

$$\underline{\hspace{2cm}} = \underline{\hspace{2cm}}$$

c.  $540 + 280$

$$\underline{\hspace{2cm}} = \underline{\hspace{2cm}}$$

d.  $380 + 430$

$$\underline{\hspace{2cm}} = \underline{\hspace{2cm}}$$

e.  $99 + 141$

$$\underline{\hspace{2cm}} = \underline{\hspace{2cm}}$$

f.  $75 + 299$

$$\underline{\hspace{2cm}} = \underline{\hspace{2cm}}$$

g.  $795 + 156$

$$\underline{\hspace{2cm}} = \underline{\hspace{2cm}}$$

## Lesson 6

**Objective:** Use the associative property to subtract from three-digit numbers and verify solutions with addition.

### Suggested Lesson Structure

■ Application Problem	(5 minutes)
■ Fluency Practice	(9 minutes)
■ Concept Development	(36 minutes)
■ Student Debrief	(10 minutes)
<b>Total Time</b>	<b>(60 minutes)</b>

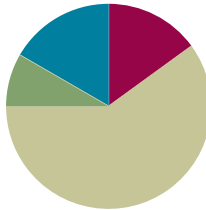

### Application Problem (5 minutes)

Maria made 60 cupcakes for the school bake sale. She sold 28 cupcakes on the first day. How many cupcakes did she have left?

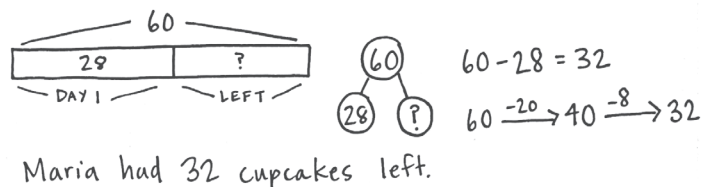

Note: This Application Problem prepares students for subtracting multiples of 10. They may use whichever subtraction strategy they prefer. Lead students through the RDW process, or have students work independently and then share their work.

### Fluency Practice (9 minutes)

- Compensation with Linking Cubes (5 minutes)
- Compensation with Subtraction (4 minutes)

### Compensation with Linking Cubes (5 minutes)

Materials: (S) Linking cubes in three colors

Note: This is a teacher-directed, whole-class activity. With continued practice, students gain automaticity compensating when subtracting.

T: (Show a row of 8 cubes with 5 in yellow and 3 in red and a row of 5 yellow cubes.) What is the difference between 8 and 5?

S: 3.

T: What is a number sentence to represent the difference?

S:  $8 - 5 = 3$ .

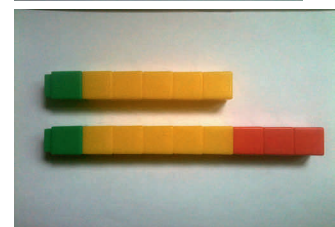
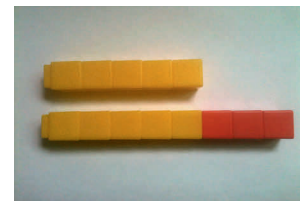

$$8 - 5 = 9 - 6$$

T: Now, add 1 green cube to the end of each stick.  
Has the difference changed?

S: No.

T: What is the new number sentence?

S:  $9 - 6 = 3$ .

T: True or false? (Write  $8 - 5 = 9 - 6$  on the board.)

S: True.

Continue with the following possible sequence:  $7 - 3 = 8 - 4$   
and  $9 - 4 = 10 - 5$ .

### Compensation with Subtraction (4 minutes)

Note: This fluency activity prepares students for the lesson by reviewing compensation when subtracting. Students add the same amount to the minuend and subtrahend to make a multiple of 10 to make the problem easier to solve. Post a tape diagram on the board for visual representation.

T: (Write  $34 - 19 = \underline{\quad}$ .) Let's use the same mental math strategy to subtract larger numbers. How much more does 19 need to make the next ten?

S: 1 more.

T: Add 1 to each number, and give me the number sentence.

S:  $35 - 20 = 15$ .

T:  $34 - 19$  is...?

S: 15.

T: True or false? (Write  $34 - 19 = 35 - 20$  on board.)

S: True.

T: What are both expressions equal to?

S: 15.

T:  $43 - 28$ . Give me the new number sentence.

S:  $45 - 30 = 15$ .

Continue with the following possible sequence:  $52 - 29$ ,  $64 - 38$ ,  $83 - 27$ ,  $74 - 49$ ,  $93 - 47$ , and  $95 - 58$ .

### Concept Development (36 minutes)

Materials: (T) Linking cubes in three colors (S) Personal white board

Note: Compensation for subtraction is always shown on the left-hand side, whether manipulating linking cubes or drawing a tape diagram, to make it clear that the difference remains the same. If compensation is shown on the right, the difference shifts, so students may wonder if it has changed.



#### NOTES ON MULTIPLE MEANS OF ENGAGEMENT:

Cultivate confidence, particularly for students who shy away from participating. Invite a student forward to add 1 green cube to the end of each stick. Guide the student to give the new number sentence, pointing to cubes as he speaks. Then, during pair-share, have a private conversation: "What does this mean?" Listen intently to see if the student understands that the difference does not change. Celebrate risk taking and problem solving!

+ 1	34
-----	----

+ 1	19
-----	----

**Problem 1: Compensation with Two-Digit Numbers and Checking with Addition**

T: Let's imagine each of the cubes is worth 10. (Show the 8 and 5 sticks used in the fluency activity.) Let's count them by tens. (Count together: 10, 20, 30, etc.)

T: What is the difference now? Say the number sentence.

S:  $80 - 50 = 30$ .

T: (Add 1 cube to the end of each stick.) How about now? Say the number sentence.

S:  $90 - 60 = 30$ .

T: (Draw a two-bar diagram to represent these two problems.)

T: Let's check to see if that worked for both of these problems. (Point to  $80 - 50$ .) In this problem, since 80 is the whole and 50 is one part, what is the other part? (Point to the 30.)

S: 30.

T: We know if we add both parts, we should get the whole again. Does it work? If we add 30 to 50, what do we get?

S: 80.

T: It works! (Write  $30 + 50 = 80$  on the board.)

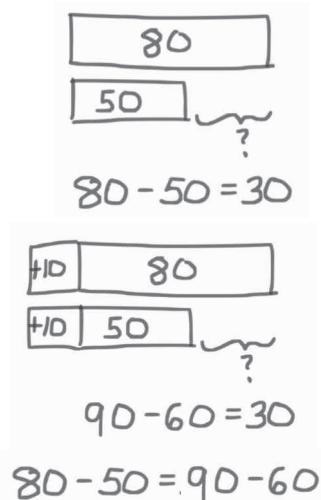

Repeat this sequence with  $90 - 60 = 30$ .

T: (Quickly draw the bonds as exemplified to the right.) Both bonds have the same missing part!

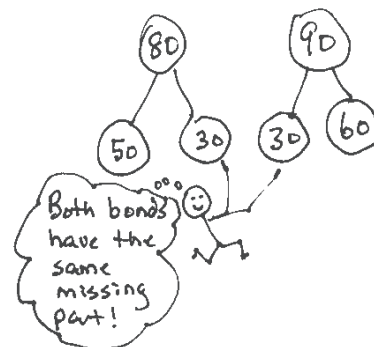
**Problem 2: Compensation with Multiples of 10 and Three-Digit Numbers and Checking with Addition**

T: Let's try a new problem. (Write  $230 - 180$  on the board.)

T: This problem is a bit challenging, isn't it?

T: What is  $250 - 200$ ?

S: 50.

T: How did you know that so fast?

S: Because the hundreds were the same, so 50 is left. → It's easy! Just take away 200. → I started at 200, and 50 more is 250, so the answer is 50.

T: It's easier to take away the hundreds, isn't it?

T: (Draw a tape diagram on the board to represent  $230 - 180$ . Direct students to do the same. Call a student volunteer forward to label the tape diagram.)

T: Can you tell me how  $230 - 180$  and my other problem,  $250 - 200$ , are related? Turn and talk.

S:  $230 - 180$  is the same as  $250 - 200$ , but you added 20 more to each number. → The difference is the same, 50. → Even though the number sentence is different, they are equal to each other.

T: Exactly! We call this **compensation**. We can add the same amount to both numbers to make an equivalent, but easier, problem!

T: (Call on a volunteer to add 20 to each bar on the board to change the model to  $250 - 200$ .)



- S: (Do the same at their seats.)
- T: Now, how much is each bar worth?
- S: The top bar is 250, and the bottom bar is 200.
- T: We added 20 to each bar to make the problem easy!
- T: Now, let's check it with addition the way we did before. (Point and talk.) What is  $50 + 200$ ?
- S: 250.
- T: What is  $50 + 180$ ? (Give students a moment to think.)
- S: 230.
- T: How do you know? Talk with a partner.
- S: The parts go together to make the same whole.  
→ I counted by tens just to make sure. → It's like a number bond, so the subtraction and addition problems are related.
- T: (Write on the board:  $330 - 280$ ,  $500 - 370$ , and  $570 - 380$ .) Now, it's your turn. On your personal white board, solve these problems by using this strategy.



### NOTES ON MULTIPLE MEANS OF ACTION AND EXPRESSION:

Some students may struggle to see the compensation. Allow them to continue using the linking cubes to represent the larger numbers. Again, instruct them to show the compensation with an alternate color.

For students struggling with fine motor skills, provide square tiles to help them draw the tape diagrams. Do not, however, become overly concerned with precision because their conceptual understanding is paramount. The tape diagram is a vehicle for understanding the compensation.

### Problem 3: Compensation with Three-Digit Numbers and Checking with Addition

- T: So far, we have only been working with numbers with zero ones. Now, let's try subtracting numbers with some ones.
- T: (Write  $321 - 199$  on the board.) In this problem, I see that the number I am taking away is very close to 200. How much more do I need to add to make 200?
- S: 1.
- T: Let's draw a tape diagram for that. (Draw a tape diagram representing  $321 - 199$ , and add 1 to the left of each bar.) Draw this on your personal white board, too.
- T: What is our new problem?
- S:  $322 - 200$ .
- T: That's easier, don't you think? Turn your board over when you have the answer.
- T: What is  $322 - 200$ ?
- S: 122.
- T: Let's check that with addition. (Write  $122 + 200$  on the board.) What is the sum?
- S: 322.
- T: It works! Let's try another problem. (Write  $514 - 290$  on the board below a tape diagram.)
- T: How much should we add to each number to make this problem easier?
- S: 10.

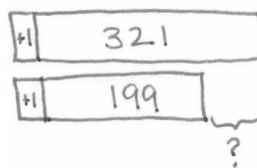
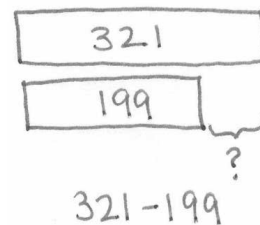

$$321 - 199 = 322 - 200 = 122$$

T: What is our new problem? (Draw 10 more onto the left of each bar.)

S:  $524 - 300$ .

T: Draw a tape diagram and solve. Check your answer using addition.

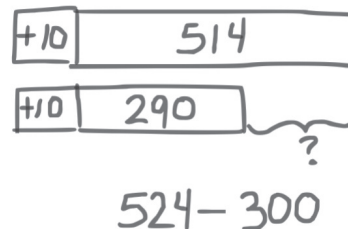

Repeat with the following possible sequence:  $547 - 498$  and  $720 - 575$ .

### Problem Set (10 minutes)

Students should do their personal best to complete the Problem Set within the allotted 10 minutes. For some classes, it may be appropriate to modify the assignment by specifying which problems they work on first. Some problems do not specify a method for solving. Students should solve these problems using the RDW approach used for Application Problems.

### Student Debrief (10 minutes)

**Lesson Objective:** Use the associative property to subtract from three-digit numbers and verify solutions with addition.

The Student Debrief is intended to invite reflection and active processing of the total lesson experience.

Invite students to review their solutions for the Problem Set. They should check work by comparing answers with a partner before going over answers as a class. Look for misconceptions or misunderstandings that can be addressed in the Student Debrief. Guide students in a conversation to debrief the Problem Set and process the lesson.

Any combination of the questions below may be used to lead the discussion.

- In Problem 1(b), what number did you add to both numbers in the equation to make an easier problem? Why? How did you check your work?
- For Problem 1(c),  $400 - 280$ , explain to your partner your strategy to solve. Then, compare how you checked your work. Make a prediction: Why will this be easier than using vertical form to solve?
- Share with a partner: What was your new number sentence for Problem 1(e)? What is the solution? What other simplifying strategies could you use to check your work?

Name EMMA Date \_\_\_\_\_

1. Draw and label a tape diagram to show how to simplify the problem. Write the new equation, and then subtract.

a.  $220 - 190 = \underline{230 - 200} = \underline{30}$

b.  $320 - 190 = \underline{330 - 200} = \underline{130}$

c.  $400 - 280 = \underline{420 - 300} = \underline{120}$

d.  $470 - 280 = \underline{490 - 300} = \underline{190}$

e.  $530 - 270 = \underline{560 - 300} = \underline{260}$

- What main difference do you notice between the problems on pages 1 and 2 of the Problem Set? How are they different? How is your goal the same?
- For Problems 1(b) and (c), convince me that **compensation** is a smart strategy to select.
- Explain what the compensation and number bond strategies have in common. What actions do you take to make solving easier?

### Exit Ticket (3 minutes)

After the Student Debrief, instruct students to complete the Exit Ticket. A review of their work will help with assessing students' understanding of the concepts that were presented in today's lesson and planning more effectively for future lessons. The questions may be read aloud to the students.

2. Draw and label a tape diagram to show how to simplify the problem. Write a new equation, and then subtract. Check your work using addition.

a.  $451 - 199 =$   $452 - 200 = 252$

+1	451	Check: $252 + 200 = 452$
+1	199	

b.  $562 - 299 =$   $563 - 300 = 263$

+1	562	Check: $263 + 300 = 563$
+1	299	

c.  $432 - 298 =$   $434 - 300 = 134$

+2	432	Check: $134 + 300 = 434$
+2	298	

d.  $612 - 295 =$   $617 - 300 = 317$

+5	612	Check: $317 + 300 = 617$
+5	295	

Name \_\_\_\_\_

Date \_\_\_\_\_

1. Draw and label a tape diagram to show how to simplify the problem. Write the new equation, and then subtract.

a.  $220 - 190 = \underline{230 - 200} = \underline{\hspace{2cm}}$

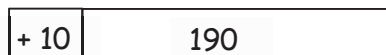
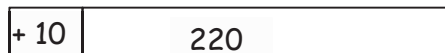

b.  $320 - 190 = \underline{\hspace{2cm}} = \underline{\hspace{2cm}}$



c.  $400 - 280 = \underline{\hspace{2cm}} = \underline{\hspace{2cm}}$

d.  $470 - 280 = \underline{\hspace{2cm}} = \underline{\hspace{2cm}}$

e.  $530 - 270 = \underline{\hspace{2cm}} = \underline{\hspace{2cm}}$

2. Draw and label a tape diagram to show how to simplify the problem. Write a new equation, and then subtract. Check your work using addition.

a.  $451 - 199 = \underline{452 - 200} = \underline{\hspace{2cm}}$

+ 1	451	Check:
+ 1	199	

b.  $562 - 299 = \underline{\hspace{2cm}} = \underline{\hspace{2cm}}$

	Check:
--	--------

c.  $432 - 298 = \underline{\hspace{2cm}} = \underline{\hspace{2cm}}$

	Check:
--	--------

d.  $612 - 295 = \underline{\hspace{2cm}} = \underline{\hspace{2cm}}$

	Check:
--	--------

Name \_\_\_\_\_

Date \_\_\_\_\_

Draw and label a tape diagram to show how to simplify the problem. Write the new equation, and then subtract.

1.  $363 - 198 = \underline{\hspace{2cm}} = \underline{\hspace{2cm}}$

2.  $671 - 399 = \underline{\hspace{2cm}} = \underline{\hspace{2cm}}$

3.  $862 - 490 = \underline{\hspace{2cm}} = \underline{\hspace{2cm}}$

Name \_\_\_\_\_

Date \_\_\_\_\_

1. Draw and label a tape diagram to show how to simplify the problem. Write the new equation, and then subtract.

a.  $340 - 190 = \underline{350 - 200} = \underline{\quad}$

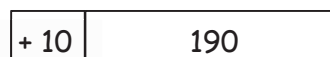
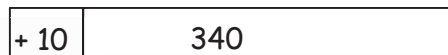

b.  $420 - 190 = \underline{\quad} = \underline{\quad}$



c.  $500 - 280 = \underline{\quad} = \underline{\quad}$

d.  $650 - 280 = \underline{\quad} = \underline{\quad}$

e.  $740 - 270 = \underline{\quad} = \underline{\quad}$

2. Draw and label a tape diagram to show how to simplify the problem. Write a new equation, and then subtract. Check your work using addition.

a.  $236 - 99 = \underline{237 - 100} = \underline{\hspace{2cm}}$

<table border="1" style="margin-left: auto; margin-right: auto;"> <tr> <td style="padding: 2px 10px;">+ 1</td> <td style="padding: 2px 10px;">236</td> </tr> <tr> <td style="padding: 2px 10px;">+ 1</td> <td style="padding: 2px 10px;">99</td> </tr> </table>	+ 1	236	+ 1	99	Check:
+ 1	236				
+ 1	99				

b.  $372 - 199 = \underline{\hspace{2cm}} = \underline{\hspace{2cm}}$

	Check:
--	--------

c.  $442 - 298 = \underline{\hspace{2cm}} = \underline{\hspace{2cm}}$

	Check:
--	--------

d.  $718 - 390 = \underline{\hspace{2cm}} = \underline{\hspace{2cm}}$

	Check:
--	--------



## Lesson 7

**Objective:** Share and critique solution strategies for varied addition and subtraction problems within 1,000.

### Suggested Lesson Structure

■ Application Problem	(5 minutes)
■ Fluency Practice	(10 minutes)
■ Concept Development	(35 minutes)
■ Student Debrief	(10 minutes)
<b>Total Time</b>	<b>(60 minutes)</b>

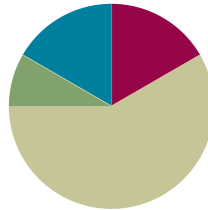

### Application Problem (5 minutes)

Jeannie got a pedometer to count her steps. The first hour, she walked 43 steps. The next hour, she walked 48 steps.

- How many steps did she walk in the first two hours?
- How many more steps did she walk in the second hour than in the first?

a.

Jeannie walked 91 steps in the first two hours.

b.

Jeannie walked 5 more steps in the second hour than in the first hour.

**Note:** This problem invites students to apply strategies from the previous lessons. They may work alone or with partners. Guide struggling students in drawing tape diagrams to represent the problem, especially for the second step. Encourage students to explain their thinking about why they used the strategy they chose.

**Fluency Practice (10 minutes)**

- Making the Next Hundred to Add (5 minutes)
- Compensation with Subtraction (5 minutes)

**Making the Next Hundred to Add (5 minutes)**

Note: Students review foundations that lead into today's lesson.

- T: When I say 9 tens + 4 tens, you say 10 tens + 3 tens.  
Ready? 9 tens + 4 tens.
- S: 10 tens + 3 tens.
- T: Answer in standard form?
- S: 130.
- T:  $90 + 40$ .
- S: 130.

Post on board:

$$90 + 40 = \underline{\quad}$$

$$\begin{array}{r} \wedge \\ 10 \quad 30 \end{array}$$

$$90 + 10 = 100$$

$$100 + 30 = \underline{\quad}$$

Continue with the following possible sequence: 19 tens + 4 tens, 29 tens + 4 tens, 29 tens + 14 tens, 9 tens + 6 tens, 19 tens + 6 tens, 19 tens + 16 tens, 29 tens + 16 tens, 8 tens + 3 tens, 18 tens + 3 tens, 18 tens + 13 tens, 28 tens + 13 tens, 8 tens + 5 tens, 18 tens + 15 tens, and 28 tens + 15 tens.

**Compensation with Subtraction (5 minutes)**

Note: This fluency activity prepares students for today's lesson by reviewing compensation when subtracting. Students add the same amount to the minuend and subtrahend to make a multiple of 10, thus making the problem easier to solve. Post the tape diagram on the board for visual representation.

- T: (Write  $34 - 19 = \underline{\quad}$ .) Let's use a simplifying strategy to subtract. What needs to be added to 19 to make the next ten?
- S: 1 more.
- T: Add 1 to each number, and give me the simplified number sentence.
- S:  $35 - 20 = 15$ .
- T: So  $34 - 19$  is...?
- S: 15.
- T: True or false? (Write  $34 - 19 = 35 - 20$  on board.)
- S: True.
- T: What are both expressions equal to?
- S: 15.
- T:  $43 - 28$ . Give me the simplified number sentence.
- S:  $45 - 30 = 15$ .

+ 1	34
+ 1	19

Continue with the following possible sequence:  $52 - 29$ ,  $64 - 38$ ,  $83 - 27$ ,  $74 - 49$ ,  $93 - 47$ , and  $95 - 58$ .

### Concept Development (35 minutes)

Materials: (T) Student work samples (Template) (S) Personal white board

#### Problem 1: $697 + 223$

- T: (Write  $697 + 223$ .) The problem is  $697 + 223$ . Turn and talk to your partner about how you would solve this problem.
- T: (Project Student A's sample.) How did Student A solve this problem? Explain to your partner what this student was thinking. What strategy did Student A use?
- S: She used number bonds to make a new hundred.  
→ She made  $700 + 220$  to get 920. → She was thinking that she could easily make a hundred because 697 is only 3 away from 700.
- T: (Label student work *number bond strategy*.)
- T: Let's look at a different way to solve this. (Project Student B's work.)
- T: What did Student B choose to do? Turn and talk.
- S: He used the arrow way. → First, he used arrows to make a new hundred, and then he added the hundreds and tens.
- T: (Label student work *arrow way*.)
- T: Which way would you do it? Discuss with your partner.
- S: I would use the number bond because it's so easy to add the hundreds after that. → The arrow helps me make sure I don't miss any parts of the number.
- T: Both work. For this one I would use the number bond. It's fewer steps, and I'm always looking for the shortest route!

#### Problem 2: $864 - 380$

- T: (Write  $864 - 380$ .) How would you solve this problem? Solve it on your personal white board, and discuss with a partner.
- T: (Circulate and listen while students solve and discuss.)
- T: (Project the work samples from Students C and D.) Let's see how these two students solved the problem. One is correct, and one is incorrect. Which is which, and why? Discuss with a partner.
- S: Student C used a number bond, but he did it wrong. He added 20 to 380, but he took 20 away from 864. → That means the numbers got closer. The difference changed. Student D kept the difference the same. → The second one is right. When you add the same number to both numbers, the difference stays the same. The first one gave us the wrong answer.



#### NOTES ON MULTIPLE MEANS OF ENGAGEMENT:

For students working below grade level, assign a buddy who can clarify processes and comfortably evaluate student work samples. As some students model their higher-level thinking, they unknowingly encourage their buddies to make connections between problem-solving strategies.

Student A

$$\begin{array}{r} 697 + 223 \\ \hline 700 + 220 = 920 \end{array}$$

Student B

$$697 \xrightarrow{+3} 700 \xrightarrow{+200} 900 \xrightarrow{+20} 920$$

Student C

$$\begin{array}{r} 864 - 380 \\ \hline 844 \quad 20 \\ 844 - 400 = 444 \end{array}$$

Student D

$$\begin{array}{r} \boxed{+20} \quad 864 \\ \boxed{+20} \quad 380 \\ \hline 884 - 400 = 484 \end{array}$$

T: I even see grown-ups make this mistake! To keep the difference the same, we have to do the same thing to both numbers when we subtract.

### Problem 3: 490 + 275

Have students solve this problem, switch boards with their partners, and then follow these steps:

- Check to see if you got the same answer.
- Figure out and fix any mistakes.
- Study the strategy your partner used.
- Explain your partner's strategy. Take turns.
- Compare how your strategies are the same and how they are different.
- Decide which strategy is more efficient.
- Give your partner a compliment about his or her work. Be specific!

If time permits, repeat partner work following the suggested sequence:  $380 + 223$ ,  $546 - 330$ , and  $811 - 692$ .

### Problem Set (10 minutes)

Students should do their personal best to complete the Problem Set within the allotted 10 minutes. For some classes, it may be appropriate to modify the assignment by specifying which problems they work on first. Some problems do not specify a method for solving. Students should solve these problems using the RDW approach used for Application Problems.

### Student Debrief (10 minutes)

**Lesson Objective:** Share and critique solution strategies for varied addition and subtraction problems within 1,000.

The Student Debrief is intended to invite reflection and active processing of the total lesson experience.

Invite students to review their solutions for the Problem Set. They should check work by comparing answers with a partner before going over answers as a class.

Look for misconceptions or misunderstandings that can be addressed in the Student Debrief.

Guide students in a conversation to debrief the Problem Set and process the lesson.



#### NOTES ON MULTIPLE MEANS OF REPRESENTATION:

Teach and post conversation starters to enhance the quality of pair-share conversations:

- I noticed that you...
- Your solution is different from/the same as mine because...
- I agree/disagree because...
- I like the way you...
- This strategy is more efficient because...

Name: Jake Date: \_\_\_\_\_

1. Circle the student work that shows a *correct* solution to  $543 + 290$ .

$\begin{array}{r} 543 + 290 = 533 + 300 = 833 \\ \quad \quad \quad \uparrow \\ \quad \quad \quad 10 \end{array}$	<p>Explain the mistake in any of the incorrect solutions.</p> <p>When adding two numbers, you can't add on to make a hundred (that will make the answer bigger and wrong). You can only use that strategy when subtracting.</p>		
$543 + 290 = 553 + 300 = 853$			
<table border="1"> <tr><td>543</td></tr> <tr><td>290</td></tr> </table>	543	290	
543			
290			
$543 \xrightarrow{+200} 743 \xrightarrow{+60} 803 \xrightarrow{+30} 833$			

2. Circle the student work that *correctly* shows a strategy to solve  $721 - 490$ .

$\begin{array}{r} 721 - 490 = 711 - 500 = 211 \\ \quad \quad \quad \uparrow \\ \quad \quad \quad 10 \end{array}$	<table border="1"> <tr><td>721</td></tr> <tr><td>490</td></tr> </table> $731 - 500 = 231$	721	490
721			
490			

Fix the work that is *incorrect* by making a new drawing in the space below with a matching number sentence.

$$721 - 490 = 231$$

$$721 \xrightarrow{-400} 321 \xrightarrow{-20} 301 \xrightarrow{-70} 231$$

Any combination of the questions below may be used to lead the discussion.

- For Problem 1, explain to your partner the mistake made in the second student work sample. Is compensation for addition the same as for subtraction? Can you add the same amount to both addends without changing the total?
- In Problem 2, which student work sample incorrectly shows a strategy to solve  $721 - 490$ ? Share your new drawing and number sentence with a partner. How else could you have solved this problem?
- Which strategy do you prefer for solving Problem 3—the arrow way or a number bond? Why? What made the arrow way more challenging?
- What were you thinking when you selected a solution strategy to solve Problem 4? How was this similar to or different from your partner's strategy?
- What was the most important thing you learned today?

3. Two students solved  $636 + 294$  using two different strategies.

*easier*

$$636 + 294 = 630 + 300 = 930$$

$\begin{matrix} \wedge \\ 630 & 6 \end{matrix}$

636  $\xrightarrow{+4}$  640  $\xrightarrow{+60}$  700  $\xrightarrow{+30}$  730  $\xrightarrow{+200}$  930

Explain which strategy would be easier to use when solving and why.

Making 100 is easier because it's fewer steps, which means less chance of mistake. Using the arrow way would mean you need to break 294 apart many times.

4. Circle one of the strategies below, and use the circled strategy to solve  $290 + 374$ .

<p>a.</p> <p style="text-align: center;">arrow way / <span style="border: 1px solid black; border-radius: 50%; padding: 2px;">number bond</span></p>	<p>b. Solve:</p> $\begin{array}{r} 290 + 374 \\ 10 \wedge 364 \\ 300 + 364 = 664 \end{array}$
--	---

c. Explain why you chose that strategy.

Using a number bond to make 100 was efficient because it's easy to add on hundreds.

---

### Exit Ticket (3 minutes)

After the Student Debrief, instruct students to complete the Exit Ticket. A review of their work will help with assessing students' understanding of the concepts that were presented in today's lesson and planning more effectively for future lessons. The questions may be read aloud to the students.

Name \_\_\_\_\_

Date \_\_\_\_\_

1. Circle the student work that shows a *correct* solution to  $543 + 290$ .

$543 + 290 = 533 + 300 = 833$ $\begin{array}{r} \phantom{5}43 \\ \phantom{5}33 \phantom{0} \\ \hline 533 \phantom{0} \end{array}$	<p>Explain the mistake in any of the incorrect solutions.</p> <hr/> <hr/> <hr/> <hr/> <hr/>
$543 + 290 = 553 + 300 = 853$ <div style="border: 1px solid black; padding: 2px; display: inline-block; margin: 5px;">+10   543</div> <div style="border: 1px solid black; padding: 2px; display: inline-block; margin: 5px;">+10   290</div>	
$543 \xrightarrow{+200} 743 \xrightarrow{+60} 803 \xrightarrow{+30} 833$	

2. Circle the student work that *correctly* shows a strategy to solve  $721 - 490$ .

$$721 - 490 = 711 - 500 = 211$$

$$\begin{array}{r} 721 \\ 711 \phantom{0} \\ \hline 711 \phantom{0} \end{array}$$

+10 | 721

+10 | 490

$$731 - 500 = 231$$

Fix the work that is *incorrect* by making a new drawing in the space below with a matching number sentence.

3. Two students solved  $636 + 294$  using two different strategies.

$$636 \xrightarrow{+4} 640 \xrightarrow{+60} 700 \xrightarrow{+30} 730 \xrightarrow{+200} 930$$

$$\begin{array}{r} 636 + 294 = 630 + 300 = 930 \\ \quad \quad \quad \wedge \\ 630 \quad 6 \end{array}$$

Explain which strategy would be easier to use when solving and why.

---



---



---

4. Circle one of the strategies below, and use the circled strategy to solve  $290 + 374$ .

<p>a.</p> <p style="text-align: center;"><i>arrow way / number bond</i></p>	<p>b. Solve:</p>
---	------------------

- c. Explain why you chose that strategy.

---



---



---

Name \_\_\_\_\_

Date \_\_\_\_\_

Circle one of the strategies below, and use the circled strategy to solve  $490 + 463$ .

a.  <i>arrow way / number bond</i>	b. Solve:
--	-----------

c. Explain why you chose that strategy.

---

---

---



Name \_\_\_\_\_

Date \_\_\_\_\_

1. Solve each problem with a written strategy such as a tape diagram, a number bond, the arrow way, the vertical form, or chips on a place value chart.

a. $370 + 300 = \underline{\quad}$	b. $\underline{\quad} = 562 - 200$	c. $\underline{\quad} + 500 = 812$
d. $230 - 190 = \underline{\quad}$	e. $\underline{\quad} = 640 - 180$	f. $450 - 290 = \underline{\quad}$

2. Use the arrow way to complete the number sentences.

a. $420 - 230 = \underline{\quad}$	b. $340 - 160 = \underline{\quad}$	c. $710 - 350 = \underline{\quad}$
---------------------------------------	---------------------------------------	---------------------------------------

3. Solve  $667 + 295$  using two different strategies.

a.	b.
----	----

c. Explain which strategy is easier to use when solving and why.

---

---

---

4. Circle one of the strategies below, and use the circled strategy to solve  $199 + 478$ .

a.	b. Solve:
<i>arrow way / number bond</i>	

c. Explain why you chose that strategy.

---

---

---





## Topic B

# Strategies for Composing Tens and Hundreds Within 1,000

<b>Focus Standards:</b>	<ul style="list-style-type: none"> <li>Add and subtract within 1000, using concrete models or drawings and strategies based on place value, properties of operations, and/or the relationship between addition and subtraction; relate the strategy to a written method. Understand that in adding or subtracting three-digit numbers, one adds or subtracts hundreds and hundreds, tens and tens, ones and ones; and sometimes it is necessary to compose or decompose tens or hundreds.</li> <li>Explain why addition and subtraction strategies work, using place value and the properties of operations. (Explanations may be supported by drawings or objects.)</li> </ul>
<b>Instructional Days:</b>	5
<b>Coherence -Links from:</b>	G1–M6 Place Value, Comparison, Addition and Subtraction to 100
<b>-Links to:</b>	G3–M2 Place Value and Problem Solving with Units of Measure

Module 5, Topic B extends the work of Module 4, Topic B. In Module 4, students composed tens while adding and subtracting within 200. Module 5 expands upon this work as students compose tens and hundreds within 1,000. The work of Topic A transitions naturally into Topic B; students employ concrete and pictorial representations of the vertical algorithm when they encounter addition problems for which there is no clear simplifying strategy.

In Lessons 8 and 9, students continue to build their conceptual understanding as they relate manipulatives to the algorithm, recording compositions as new groups below in vertical form as they did in Module 4. As they move the manipulatives, students use place value language to express the action and physically exchange 10 ones for 1 ten and 10 tens for 1 hundred, if necessary. They record each change in the vertical form, step-by-step.

In Lessons 10 and 11, students move from concrete to pictorial representations as they draw chip models to represent addition within 1,000. As they did with the manipulatives, students record each action in their drawings step-by-step on the vertical form (pictured to the right).

The diagrams show the following steps:

- Initial state: Place value chart with 4 hundreds, 2 tens, and 8 ones; and 2 hundreds, 9 tens, and 3 ones. Vertical form: 
$$\begin{array}{r} 428 \\ + 293 \\ \hline \end{array}$$
- Step 1: 10 ones are grouped into 1 ten. Vertical form: 
$$\begin{array}{r} 428 \\ + 293 \\ \hline 1 \end{array}$$
- Step 2: 10 tens are grouped into 1 hundred. Vertical form: 
$$\begin{array}{r} 428 \\ + 293 \\ \hline 21 \end{array}$$
- Final state: 100s column has 6 hundreds, 10s column has 1 ten, and 1s column has 1 one. Vertical form: 
$$\begin{array}{r} 428 \\ + 293 \\ \hline 721 \end{array}$$

In Lesson 12, students are presented with a variety of problems for which they must choose an appropriate strategy to solve. Students are encouraged to be flexible in their thinking and defend their reasoning using place value language. They may choose to represent and solve problems using number bonds, the arrow way, place value disks, or chip models.

### A Teaching Sequence Toward Mastery of Strategies for Composing Tens and Hundreds Within 1,000

**Objective 1: Relate manipulative representations to the addition algorithm.**  
(Lessons 8–9)

**Objective 2: Use math drawings to represent additions with up to two compositions and relate drawings to the addition algorithm.**  
(Lessons 10–11)

**Objective 3: Choose and explain solution strategies and record with a written addition method.**  
(Lesson 12)

## Lesson 8

**Objective:** Relate manipulative representations to the addition algorithm.

### Suggested Lesson Structure

■ Application Problem	(5 minutes)
■ Fluency Practice	(12 minutes)
■ Concept Development	(33 minutes)
■ Student Debrief	(10 minutes)
<b>Total Time</b>	<b>(60 minutes)</b>

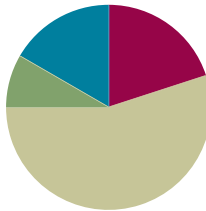

### Application Problem (5 minutes)

Susan has 37 pennies.

M. J. has 55 more pennies than Susan.

- How many pennies does M. J. have?
- How many pennies do they have altogether?

Note: Some students may read Part (b) and incorrectly add  $37 + 55$ . Once the students have been given the opportunity to solve using any number of written strategies, invite some to share their representations of the problem.

a.

MJ has 92 pennies.

b.

Altogether Susan and MJ have 129 pennies.

### Fluency Practice (12 minutes)

- Add Common Units (3 minutes)
- Sprint: Two-Digit Addition (9 minutes)

### Add Common Units (3 minutes)

Materials: (S) Personal white board

Note: Reviewing this mental math fluency activity prepares students for understanding the importance of the written addition method.

- T: 2 puppies plus 1 puppy is...?  
S: 3 puppies.  
T: 3 dogs, 2 puppies, plus 1 puppy is...?  
S: 3 dogs 3 puppies.  
T: (Project 303.) Say the number in unit form.  
S: 3 hundreds 3 ones.  
T: (Write  $303 + 202 = \underline{\quad}$ .) Say the addition sentence and answer in unit form.  
S: 3 hundreds 3 ones + 2 hundreds 2 ones = 5 hundreds 5 ones.  
T: Write the addition sentence on your personal white board.  
S: (Write  $303 + 202 = 505$ .)

Repeat this process for the following possible sequence:  $404 + 203$ ,  $660 + 110$ ,  $707 + 220$ ,  $770 + 202$ , and  $440 + 340$ .

### Sprint: Two-Digit Addition (9 minutes)

Materials: (S) Two-Digit Addition Sprint

Note: Students review two-digit addition in preparation for adding three-digit numbers in today's lesson.

### Concept Development (33 minutes)

Materials: (T) Place value disks, unlabeled hundreds place value chart (Lesson 1 Template 2) (S) Personal white board, unlabeled hundreds place value chart (Lesson 1 Template 2), place value disks (9 hundreds, 18 tens, 18 ones) per pair

- T: What is  $200 + 300$ ?  
S: 500.  
T: Explain your strategy for solving to your partner for 15 seconds.  
S: I started at 300, and I counted on 2 more hundreds.  $\rightarrow 2 + 3 = 5$ , so 2 hundreds + 3 hundreds is 5 hundreds.  
T: What is  $440 + 200$ ?  
S: 640.  
T: Explain your strategy for solving to your partner for 15 seconds.  
S: I started at 440, and I counted on 2 hundreds, so 440, 540, 640.  $\rightarrow$  I know that  $400 + 200$  is 600, and then I just added on 40.  
T: What is  $287 + 314$ ?  
S: (Solve problem with partner or independently.)  
S: 601.  
T: Why was this problem more difficult to solve mentally?  
S: We weren't just adding on another hundred.  $\rightarrow$  It's easy to add on hundreds and tens.  $\rightarrow$  This time, we had to worry about the ones place, too.

- T: What would be a better way to solve this problem to make sure we get the right answer?
- S: Use place value disks and a place value chart. → Make a math drawing, and show new units on the vertical form.
- T: Yes. Let's try a few more problems that might require using the algorithm. Remember, that's what we call the steps we take when we solve in vertical form.

Note: In the following modeled activity, it is important to relate each action on the place value chart to the algorithm.

### Problem 1: $303 + 37$

- T: (Write  $303 + 37$  on the board horizontally.) Read the problem aloud.
- S: (Read  $303 + 37$  chorally.)
- T: Talk with your partner. How could you solve this problem using mental math?
- S:  $303 + 30 + 7$ . → Add 3 and 7, which makes 10, and then add  $300 + 30 + 10$ . →  $37 + 3$  is 40, plus the 3 hundreds is 340.
- T: Can we check our work using vertical form?
- S: Yes.
- T: Let's try that.
- T: Turn and talk: How do we set up this problem to record it vertically?
- S: Write 303 on the top and 37 on the bottom.  
→ Line up the ones and line up the tens.
- T: (Rewrite the problem vertically.)
- T: Let's solve using our place value disks and place value charts.
- T: How many hundreds do we need for the first addend, the first part?
- S: 3 hundreds!
- T: How many tens?
- S: Zero!
- T: How many ones?
- S: 3 ones!
- T: Count with me to set up the place value chart. (Point to the place value disks on the place value chart.)
- S: (Count chorally.) 100, 200, 300, 301, 302, 303.
- T: (Repeat the above process for the other part, 37.)
- T: Does this model match the vertical form?
- S: Yes!
- T: Okay, we're ready to solve! (Point to the ones disks, and then point to the ones in vertical form.)  
3 ones + 7 ones is...?
- S: 10 ones!

The image shows three stages of solving  $303 + 37$  using place value disks and a vertical form.

**Stage 1:** A place value chart with three columns (hundreds, tens, ones). The hundreds column has three red disks (100, 100, 100). The tens column has three red disks (10, 10, 10). The ones column has three green disks (1, 1, 1). To the right, the vertical form is written as  $303 + 37$ .

**Stage 2:** The same place value chart, but the three red disks in the tens column are now four (10, 10, 10, 10). The ones column has seven green disks (1, 1, 1, 1, 1, 1, 1). To the right, the vertical form is written as  $303 + 37$  with a horizontal line under the 7, and a 0 is written below the 7.

**Stage 3:** The same place value chart, but the four red disks in the tens column are now three (10, 10, 10). The ones column has one red disk (10) and one green disk (1). To the right, the vertical form is written as  $303 + 37$  with a horizontal line under the 7, and 40 is written below the 7.



- T: What do you see, and what should we do?
- S: We made a ten! → Change 10 ones for 1 ten. → Remove 10 ones, and put a ten disk in the tens place because 10 ones is 1 ten. → We should compose a new unit—a ten!
- T: That's right! We rename 10 ones as 1 ten. And where does the new unit of ten belong?
- S: In the tens place!
- T: Yes! (Model changing 10 ones for 1 ten.)
- T: How do we record new groups below using the algorithm? Turn and talk.
- S: Write 1 ten below the tens column and 0 ones below the ones column. → Write 1 on the line under the 3 in the tens place, and write 0 under the line in the ones place.
- T: Why do we write the 1 here? (Point to the line below the tens column.)
- S: Because the 1 is actually a ten. → We made a ten, so we put it in the tens column.
- T: Now, let's add the tens. (Point to the tens disks.) 0 tens + 3 tens + 1 ten?
- S: 4 tens!
- T: Did we make a new hundred?
- S: No!
- T: (Model recording 4 tens in the tens place.)
- T: Now, let's move on to the next larger unit, the hundreds. How many hundreds do we have?
- S: 3 hundreds!
- T: Turn and talk: Where do we record that on our vertical form?
- S: Write 3 in the hundreds place.
- T: What is  $303 + 37$ ?
- S: 340.
- T: Explain to your partner how each change that I modeled on my place value chart matches each step that I recorded in the vertical form.
- S: 3 ones + 7 ones is 10 ones, so we renamed 10 ones for 1 ten and wrote the 1 on the line as new groups below. → There are 4 tens, so we wrote 4 below the line in the tens place.

Distribute place value charts and place value disks. Instruct students to work with a partner on the next problem.

**Problem 2:  $211 + 95$**

- T: Now, it's your turn. (Write  $211 + 95$  on the board vertically.) Write  $211 + 95$  as I did.
- T: Turn and talk: How can we solve this mentally?
- S: I take apart the numbers  $200 + 10 + 1 + 90 + 5$ , and I get  $200 + 100 + 6$ , which is 306. → 211 plus 9 tens is 301 plus 5 more is 306.



**NOTES ON  
MULTIPLE MEANS  
OF ACTION AND  
EXPRESSION:**

For Problem 2, invite students to whisper-count as partners take turns modeling and writing each addend. They may be encouraged to count the regular way (i.e., 10, 20, 30, ...) or the Say Ten way (i.e., 2 hundreds 1 ten 1). Partners also take turns recording their actions using the algorithm. This is an opportunity to support students working below grade level through small group instruction.

T: How can we check our mental math to be sure we are correct?

S: Use place value disks. → Make a math drawing.

T: Model both addends on your place value chart.

T: We're ready to solve! Let's begin with the ones place. (Point to the ones disks.) 1 one plus 5 ones is...?

S: 6 ones.

T: Use your place value disks to show what we should do here. (Circulate to check for understanding.)

T: Let's record the total number of ones on our vertical form. (Write 6 in the ones place as students do the same.)

T: Let's move on to the tens place. (Point to the tens disks.) What are you adding?

S: 1 ten and 9 tens.

T: How many tens do we have altogether?

S: 10 tens!

T: What should we do?

S: Bundle 10 tens and make a hundred. → Change 10 ten disks for 1 hundred disk. → Compose a new unit, a hundred!

S: (Change on place value charts.)

T: Show your work in the vertical form using new groups below. (Circulate as students record 1 on the line in the hundreds place and 0 in the tens place—in that order.)

T: Now, let's add the hundreds. How many hundreds?

S: 3 hundreds!

T: Yes! You remembered to add the new unit! So, we write 3 below the line in the hundreds place.

T: Explain to your partner how your work with the place value disks and place value chart matches the vertical form.

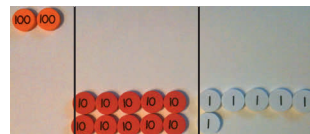
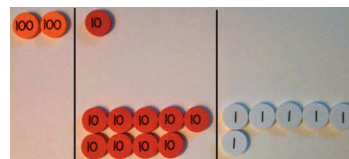

$$\begin{array}{r} 211 \\ + 95 \\ \hline 306 \end{array}$$

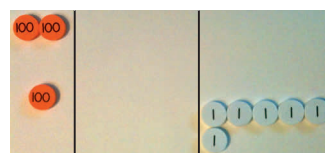

$$\begin{array}{r} 211 \\ + 95 \\ \hline 306 \end{array}$$



### NOTES ON MULTIPLE MEANS OF ENGAGEMENT

Some students struggle with precision and organization. Encourage them to visualize the ten-frame when arranging their disks into 5-groups. Also, help students line up their problems according to place value. Instruct students to use lined paper turned 90 degrees (landscape orientation) and write their numbers between the lines.

$$\begin{array}{r} 320 \\ + 243 \\ \hline 563 \end{array}$$

Continue with the following possible sequence:  $324 + 156$ ,  $546 + 273$ , and  $435 + 382$ . As students demonstrate confidence in relating their models to the algorithm, allow them to work independently on the Problem Set.

## Problem Set (10 minutes)

Students should do their personal best to complete the Problem Set within the allotted 10 minutes. For some classes, it may be appropriate to modify the assignment by specifying which problems they work on first. Some problems do not specify a method for solving. Students should solve these problems using the RDW approach used for Application Problems.

## Student Debrief (10 minutes)

**Lesson Objective:** Relate manipulative representations to the addition algorithm.

The Student Debrief is intended to invite reflection and active processing of the total lesson experience.

Invite students to review their solutions for the Problem Set. They should check work by comparing answers with a partner before going over answers as a class. Look for misconceptions or misunderstandings that can be addressed in the Student Debrief. Guide students in a conversation to debrief the Problem Set and process the lesson. Any combination of the questions below may be used to lead the discussion.

- How did you solve Problem 1(a) and (b),  $301 + 49$  and  $402 + 48$ ? Did you begin by adding the ones only? Why didn't you need to solve with place value disks? How can you check your mental math? Where did you write the new unit?
- Explain to your partner how you used manipulatives to solve Problem 1(c) and (d). Did you need to bundle a new ten or hundred? How did you know? How did you show it using the algorithm?
- For Problem 1(e) and (f), how did your work with the place value disks match the vertical form? How did you show new groups below? How were these problems different from the ones in Problem 1(c) and (d)?
- What do you notice about the answers for Problem 1(g) and (h)? If the addends in each problem are different, why are the answers the same?
- Did you notice any patterns in Problem 2 that helped you solve efficiently?
- In Problem 2, did you use a place value chart and place value disks every time you composed a new unit of ten or a hundred? How do you know when you should solve using a place value chart and place value disks, a simplifying strategy, or mental math?

Name Brooke Date \_\_\_\_\_

1. Solve the following problems using your place value chart, place value disks, and vertical form. Bundle a ten or hundred, when necessary.

a. $301 + 49$ $\begin{array}{r} 301 \\ + 49 \\ \hline 350 \end{array}$	b. $402 + 48$ $\begin{array}{r} 402 \\ + 48 \\ \hline 450 \end{array}$
c. $315 + 93$ $\begin{array}{r} 315 \\ + 93 \\ \hline 408 \end{array}$	d. $216 + 192$ $\begin{array}{r} 216 \\ + 192 \\ \hline 408 \end{array}$
e. $545 + 346$ $\begin{array}{r} 545 \\ + 346 \\ \hline 891 \end{array}$	f. $565 + 226$ $\begin{array}{r} 565 \\ + 226 \\ \hline 791 \end{array}$
g. $222 + 687$ $\begin{array}{r} 222 \\ + 687 \\ \hline 909 \end{array}$	h. $164 + 745$ $\begin{array}{r} 164 \\ + 745 \\ \hline 909 \end{array}$

2. Solve.

a.  $300 + 200 = 500$

b.  $320 + 200 = 520$

c.  $320 + 230 = 550$

d.  $320 + 280 = 600$   

$$\begin{array}{r} 300 \\ 20 \end{array}$$

e.  $328 + 286 = 614$   

$$\begin{array}{r} 320 \\ 8 \end{array}$$

f.  $600 + 80 = 680$   

$$\begin{array}{r} 600 \\ 80 \end{array}$$

g.  $600 + 180 = 780$

h.  $620 + 180 = 800$   

$$\begin{array}{r} 600 \\ 20 \end{array}$$

i.  $680 + 220 = 900$   

$$\begin{array}{r} 20 \\ 200 \end{array}$$

j.  $680 + 230 = 910$   

$$\begin{array}{r} 20 \\ 210 \end{array}$$

**Exit Ticket (3 minutes)**

After the Student Debrief, instruct students to complete the Exit Ticket. A review of their work will help with assessing students' understanding of the concepts that were presented in today's lesson and planning more effectively for future lessons. The questions may be read aloud to the students.

## A

Number Correct: \_\_\_\_\_

## Two-Digit Addition

1.	$38 + 1 =$	
2.	$47 + 2 =$	
3.	$56 + 3 =$	
4.	$65 + 4 =$	
5.	$31 + 8 =$	
6.	$42 + 7 =$	
7.	$53 + 6 =$	
8.	$64 + 5 =$	
9.	$49 + 1 =$	
10.	$49 + 2 =$	
11.	$49 + 3 =$	
12.	$49 + 5 =$	
13.	$58 + 2 =$	
14.	$58 + 3 =$	
15.	$58 + 4 =$	
16.	$58 + 6 =$	
17.	$67 + 3 =$	
18.	$57 + 4 =$	
19.	$57 + 5 =$	
20.	$57 + 7 =$	
21.	$85 + 5 =$	
22.	$85 + 6 =$	

23.	$85 + 7 =$	
24.	$85 + 9 =$	
25.	$76 + 4 =$	
26.	$76 + 5 =$	
27.	$76 + 6 =$	
28.	$76 + 9 =$	
29.	$64 + 6 =$	
30.	$64 + 7 =$	
31.	$76 + 8 =$	
32.	$43 + 7 =$	
33.	$43 + 8 =$	
34.	$43 + 9 =$	
35.	$52 + 8 =$	
36.	$52 + 9 =$	
37.	$59 + 1 =$	
38.	$59 + 3 =$	
39.	$58 + 2 =$	
40.	$58 + 4 =$	
41.	$77 + 3 =$	
42.	$77 + 5 =$	
43.	$35 + 5 =$	
44.	$35 + 8 =$	

**B**

## Two-Digit Addition

Number Correct: \_\_\_\_\_

Improvement: \_\_\_\_\_

1.	$28 + 1 =$	
2.	$37 + 2 =$	
3.	$46 + 3 =$	
4.	$55 + 4 =$	
5.	$21 + 8 =$	
6.	$32 + 7 =$	
7.	$43 + 6 =$	
8.	$54 + 5 =$	
9.	$39 + 1 =$	
10.	$39 + 2 =$	
11.	$39 + 3 =$	
12.	$39 + 5 =$	
13.	$48 + 2 =$	
14.	$48 + 3 =$	
15.	$48 + 4 =$	
16.	$48 + 6 =$	
17.	$57 + 3 =$	
18.	$57 + 4 =$	
19.	$57 + 5 =$	
20.	$57 + 7 =$	
21.	$75 + 5 =$	
22.	$75 + 6 =$	

23.	$75 + 7 =$	
24.	$75 + 9 =$	
25.	$66 + 4 =$	
26.	$66 + 5 =$	
27.	$66 + 6 =$	
28.	$66 + 9 =$	
29.	$54 + 6 =$	
30.	$54 + 7 =$	
31.	$54 + 8 =$	
32.	$33 + 7 =$	
33.	$33 + 8 =$	
34.	$33 + 9 =$	
35.	$42 + 8 =$	
36.	$42 + 9 =$	
37.	$49 + 1 =$	
38.	$49 + 3 =$	
39.	$58 + 2 =$	
40.	$58 + 4 =$	
41.	$67 + 3 =$	
42.	$67 + 5 =$	
43.	$85 + 5 =$	
44.	$85 + 8 =$	

Name \_\_\_\_\_

Date \_\_\_\_\_

1. Solve the following problems using your place value chart, place value disks, and vertical form. Bundle a ten or hundred, when necessary.

a. $301 + 49$	b. $402 + 48$
c. $315 + 93$	d. $216 + 192$
e. $545 + 346$	f. $565 + 226$
g. $222 + 687$	h. $164 + 745$

2. Solve.

a.  $300 + 200 = \underline{\hspace{2cm}}$

b.  $320 + 200 = \underline{\hspace{2cm}}$

c.  $320 + 230 = \underline{\hspace{2cm}}$

d.  $320 + 280 = \underline{\hspace{2cm}}$

e.  $328 + 286 = \underline{\hspace{2cm}}$

f.  $600 + 80 = \underline{\hspace{2cm}}$

g.  $600 + 180 = \underline{\hspace{2cm}}$

h.  $620 + 180 = \underline{\hspace{2cm}}$

i.  $680 + 220 = \underline{\hspace{2cm}}$

j.  $680 + 230 = \underline{\hspace{2cm}}$



Name \_\_\_\_\_

Date \_\_\_\_\_

Solve the following problems using your place value chart, place value disks, and vertical form. Bundle a ten or hundred, when necessary.

1.  $378 + 113$

2.  $178 + 141$

Name \_\_\_\_\_

Date \_\_\_\_\_

1. Solve the following problems using your place value chart, place value disks, and vertical form. Bundle a ten or hundred, when necessary.

a.  $505 + 75$

b.  $606 + 84$

c.  $293 + 114$

d.  $314 + 495$

e.  $364 + 326$

f.  $346 + 234$

g.  $384 + 225$

h.  $609 + 351$

2. Solve.

a.  $200 + 400 =$  \_\_\_\_\_

b.  $220 + 400 =$  \_\_\_\_\_

c.  $220 + 440 =$  \_\_\_\_\_

d.  $220 + 480 =$  \_\_\_\_\_

e.  $225 + 485 =$  \_\_\_\_\_

f.  $500 + 60 =$  \_\_\_\_\_

g.  $500 + 160 =$  \_\_\_\_\_

h.  $540 + 160 =$  \_\_\_\_\_

i.  $560 + 240 =$  \_\_\_\_\_

j.  $560 + 250 =$  \_\_\_\_\_

## Lesson 9

Objective: Relate manipulative representations to the addition algorithm.

### Suggested Lesson Structure

■ Application Problem	(6 minutes)
■ Fluency Practice	(10 minutes)
■ Concept Development	(34 minutes)
■ Student Debrief	(10 minutes)
<b>Total Time</b>	<b>(60 minutes)</b>

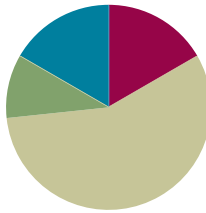

### Application Problem (6 minutes)

The table to the right represents the halftime score at a basketball game.

The red team scored 19 points in the second half.

The yellow team scored 13 points in the second half.

- Who won the game?
- By how much did that team win?

Team	Score
red team	63 points
yellow team	71 points

a.

Red	63 1st half	19 2nd half
Yellow	71 1st half	13 2nd half

$$\begin{array}{r} 63 + 19 \\ \phantom{6}2 \phantom{0} \phantom{0} \\ \phantom{6}2 + 20 = 82 \end{array}$$

$$\begin{array}{r} 71 + 13 \\ \phantom{7}1 \phantom{0} \phantom{0} \\ \phantom{7}1 \xrightarrow{+10} 81 \xrightarrow{+3} 84 \end{array}$$

The yellow team won the game. They scored 84 while the red team scored 82.

b.

red	82
yellow	84

$$84 - 82 = 2$$

The yellow team won by 2 points.

Note: This comparison problem requires multiple steps. The numbers chosen encourage students to practice simplifying and place value strategies. Invite students to reason about how they could have known who won without adding.

**Fluency Practice (10 minutes)**

- Making the Next Ten to Add (2 minutes)
- Add Common Units (2 minutes)
- More Tens and Ones (6 minutes)

**Making the Next Ten to Add (2 minutes)**

Note: This fluency activity reviews foundations that lead into today's lesson.

T: When I say  $9 + 4$ , you say  $10 + 3$ . Ready?  $9 + 4$ .

S:  $10 + 3$ .

T: Answer.

S: 13.

Continue with the following possible sequence:  $19 + 4$ ,  $9 + 6$ ,  $19 + 6$ ,  $8 + 3$ ,  $18 + 3$ ,  $8 + 5$ ,  $18 + 5$ ,  $7 + 6$ ,  $27 + 6$ ,  $7 + 4$ ,  $17 + 4$ ,  $9 + 7$ ,  $19 + 7$ ,  $8 + 6$ , and  $18 + 6$ .

**Add Common Units (2 minutes)**

Materials: (S) Personal white board

Note: Reviewing this mental math fluency activity prepares students for understanding the importance of the algorithm.

T: (Project 545.) Say the number in unit form.

S: 5 hundreds 4 tens 5 ones.

T: (Write  $545 + 232 = \underline{\quad}$ .) Say the addition sentence, and answer in unit form.

S: 5 hundreds 4 tens 5 ones + 2 hundreds 3 tens 2 ones = 7 hundreds 7 tens 7 ones.

T: Write the addition sentence on your personal white board.

S: (Write  $545 + 232 = 777$ .)

Repeat the process, and continue with the following possible sequence:  $440 + 225$ ,  $603 + 303$ ,  $211 + 644$ ,  $670 + 330$ , and  $671 + 321$ .

**More Tens and Ones (6 minutes)**

Note: Students review adding tens and ones to prepare for today's lesson.

T: What is 3 tens more than 6 tens?

S: 9 tens.

T: Give the number sentence in unit form.

S:  $6 \text{ tens} + 3 \text{ tens} = 9 \text{ tens}$ .

T: Give the number sentence in standard form.

S:  $60 + 30 = 90$ .

Post on board:

$$9 + 4 = \underline{\quad}$$

$$\wedge$$

$$1 \quad 3$$

$$9 + 1 = 10$$

$$10 + 3 = \underline{\quad}$$

T: What is 4 tens more than 6 tens? Give the answer in tens.

S: 10 tens.

T: Give the answer in hundreds.

S: 1 hundred.

T: Give the number sentence in standard form.

S:  $60 + 40 = 100$ .

Continue with the following possible sequence: 4 tens more than 6 tens 3 ones, 5 tens more than 5 tens, 5 tens more than 6 tens, 5 tens more than 6 tens 4 ones, 2 tens more than 8 tens, and 3 tens more than 8 tens.

### Concept Development (34 minutes)

Materials: (T) Place value disks (9 hundreds, 18 tens, 18 ones), personal white board (S) Place value disks (9 hundreds, 18 tens, 18 ones), unlabeled hundreds place value chart (Lesson 1 Template 2), personal white board

Note: This lesson is designed to provide students with practice relating manipulative representations to vertical form.

As students show proficiency, allow them to move on to the Problem Set. The first problem is intended for guided practice; the second problem is still guided but with less teacher support. Adjust delivery of instruction to best fit student needs.

#### Problem 1: $427 + 385$

Distribute place value disks. Students can use their desks as place value charts to model the problems below, perhaps by dividing their desks into three columns with masking tape.

T: (Write  $427 + 385$  in vertical form on the board. Next to the problem, draw a number bond showing two parts: 427 and 385.)

T: Let's solve this mentally. Where do we begin?

S: Add the hundreds ( $400 + 300 = 700$ ), then add the tens ( $20 + 80 = 100$ ), and then add the ones ( $7 + 5 = 12$ ). Then, add them together.  $700 + 100 + 12 = 812$ . → Break the second part into hundreds, tens, and ones.  $427 + 300 = 727$ ,  $727 + 80 = 807$ , and then  $807 + 5 = 812$ .

T: That might not be the easiest way for all of us. Is there another way we can solve?

S: Use place value disks. → Make a math drawing. → Solve with vertical form.

T: Use place value language to tell your partner how to show this problem using place value disks.



#### NOTES ON MULTIPLE MEANS OF REPRESENTATION:

For students working above grade level, incorporate error analysis into the lesson. Distribute a premade, half-page extension with an incorrect problem (e.g.,  $679 + 284 = 863$ ). Tell students that this is the *Math ER!* They must put on their doctor's jackets and diagnose the sick problem. On each slip of paper, ask the following two questions:

- What makes this problem *sick*?
- What steps should the doctor take to cure the problem?

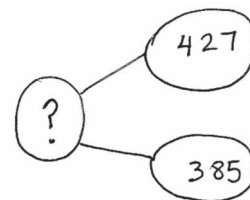

- S: Show 4 hundred disks, 2 ten disks, and 7 one disks; then, show 3 hundred disks, 8 tens, and 5 ones.  
 → Show both parts so you can add them together. → Make sure you put the place value disks in the right part of your chart. For example, 7 ones and 5 ones go in the ones column to match the vertical form.
- T: Let's all show the problem. (Model counting out place value disks as students do the same.)
- T: What should we do first to solve?
- S: Add the ones.
- T: 7 ones + 5 ones?
- S: 12 ones!
- T: What do we do when we have 10 of a unit, like 10 ones?
- S: Change 10 ones for 1 ten. → Take off the 10 ones disks and put 1 ten disk. → Rename the 10 ones as a new unit of ten.
- T: Yes! Let's do that together. (Model changing 10 ones for 1 ten.) Don't forget to show your action in vertical form. (Circulate as students show the change on the vertical form using new groups below. Because students are writing the number 12, they will write the tens digit first.)
- S: (Write the tens digit.)
- T: What do we do next?
- S: Add the tens. → Add 2 tens + 8 tens + 1 ten. → Add the tens, but don't forget the new ten that we wrote on the line.
- T: Let's add 2 tens, 8 tens, and 1 ten. How many tens altogether?
- S: 11 tens.
- T: What's next?
- S: Bundle to make a new unit, a hundred! → Change 10 tens for 1 hundred. → Take away the 10 tens disks and put a hundred disk.
- T: Yes, let's compose a new hundred! Remember to show the change on the vertical form. (Change 10 tens for 1 hundred, and show the change using new groups below as students do the same.)
- T: Are we ready to add the hundreds?
- S: Yes!
- T: What is 4 hundreds + 3 hundreds + 1 hundred?
- S: 8 hundreds!
- T: Let's record that. (Write 8 in the hundreds place as students do the same.) If 427 and 385 are the parts, what is the whole?
- S: 812.

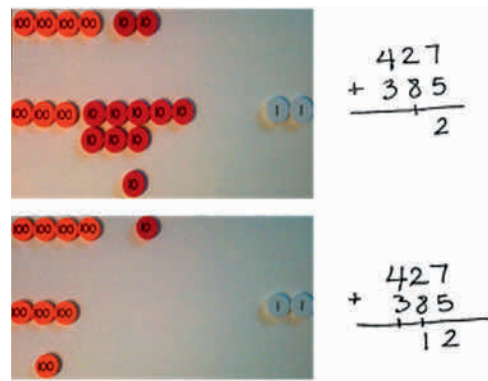

#### NOTES ON MULTIPLE MEANS OF ENGAGEMENT:

As students move toward independent practice, highlight critical vocabulary so they can ask themselves questions as they solve:

- Do I have enough *ones* or *tens* to *bundle*? (More abstractly, we can ask, “Can I *compose* a new unit?”)
- Where do I record the new *ten* or *hundred*?
- How do we show this change using vertical form?

These questions will prepare students to work independently through the Problem Set and to meaningfully contribute during the Debrief.

**Problem 2:  $672 + 249$** 

T: Write  $672 + 249$  vertically, and whisper-count as you show it with place value disks on your place value chart. (Circulate as students count out place value disks and write the problem vertically.)

T: Are we finding a part or the whole?

S: The whole.

T: What are the parts?

S: 672 and 249.

T: (Draw a number bond on the board to show the two parts and the missing whole.) Can we solve this mentally?

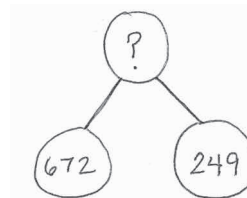

S:  $600 + 200 + 70 + 40 + 2 + 9$  equals  $800 + 110 + 11$ , which equals 921. → 672 plus 200 is 872, plus 40 is 912, plus 9 more is 921.

T: That might not be the easiest way for all of us. Let's try that with place value disks, a place value chart, and the vertical form.

T: What is the first step?

S: Add the ones. → Add 2 ones + 9 ones, which is 11 ones.

T: What do you do next? Discuss with your partner.

S: Make a ten! → Change 10 ones for 1 ten, and record it in new groups below. → Compose a ten, and then you'll have 1 one leftover.

T: Okay, show me with your place value disks, and record it on the vertical form. (Circulate as students work, and check for understanding.)

T: Turn and talk: What is our next step?

S: Move on to the tens. → Add the tens, and don't forget the new one! → Add 7 tens + 4 tens + 1 ten.

T: You've got it! Show me and record it! (Circulate and check for understanding.)

T: What is our next step?

S: Add the hundreds. → Add 6 hundreds + 2 hundreds + 1 hundred.

T: One last time, show me and record it! (Circulate and check for understanding.)

T: So, what is  $672 + 249$ ?

S: 921.

If students show proficiency after the two problems above, allow them to move on to the Problem Set. Otherwise, continue with the following suggested sequence:  $671 + 149$ ,  $348 + 464$ , and  $563 + 247$ .

**Problem Set (10 minutes)**

Students should do their personal best to complete the Problem Set within the allotted 10 minutes. For some classes, it may be appropriate to modify the assignment by specifying which problems they work on first. Some problems do not specify a method for solving. Students should solve these problems using the RDW approach used for Application Problems.



## Student Debrief (10 minutes)

**Lesson Objective:** Relate manipulative representations to the addition algorithm.

The Student Debrief is intended to invite reflection and active processing of the total lesson experience.

Invite students to review their solutions for the Problem Set. They should check work by comparing answers with a partner before going over answers as a class. Look for misconceptions or misunderstandings that can be addressed in the Student Debrief. Guide students in a conversation to debrief the Problem Set and process the lesson.

Any combination of the questions below may be used to lead the discussion.

- Did you solve any problems on the first page mentally or with a simplifying strategy? Which ones? Explain your thinking.
- Explain to your partner how you used manipulatives to set up Problem 1(a). How did you change your place value disks to show Problem 1(b)? What actions did you take to solve?
- For Problem 1(c), how did your work with the place value disks match the vertical form? How did you show new groups below?
- Explain to your partner how you solved Problem 1(e). Did you need to compose a ten or hundred for Problem 1(f)? Why not? Why was the total the same for both problems?
- In Problem 2, which problems were you able to solve mentally? Did you use manipulatives to solve any of these problems? Why or why not?
- Use place value language and explain to your partner how you solved Problem 2(a–d) mentally. Or explain how your place value disks and vertical form changed as you worked through the problems.

Name Benny Date \_\_\_\_\_

1. Solve the following problems using place value disks, a place value chart, and vertical form.

a. $417 + 293$ $\begin{array}{r} 417 \\ + 293 \\ \hline 710 \end{array}$	b. $526 + 185$ $\begin{array}{r} 526 \\ + 185 \\ \hline 711 \end{array}$
c. $338 + 273$ $\begin{array}{r} 338 \\ + 273 \\ \hline 611 \end{array}$	d. $625 + 186$ $\begin{array}{r} 625 \\ + 186 \\ \hline 811 \end{array}$
e. $250 + 530$ $\begin{array}{r} 250 \\ + 530 \\ \hline 780 \end{array}$	f. $243 + 537$ $\begin{array}{r} 243 \\ + 537 \\ \hline 780 \end{array}$
g. $376 + 624$ $\begin{array}{r} 376 \\ + 624 \\ \hline 1000 \end{array}$	h. $283 + 657$ $\begin{array}{r} 283 \\ + 657 \\ \hline 940 \end{array}$

2. Solve.

a.  $270 + 430 = 700$   

$$\begin{array}{c} \phantom{2} \uparrow \phantom{0} \\ 30 \quad 400 \end{array}$$

b.  $260 + 440 = 700$   

$$\begin{array}{c} \phantom{2} \uparrow \phantom{0} \\ 40 \quad 400 \end{array}$$

c.  $255 + 445 = 700$   

$$\begin{array}{c} \phantom{2} \uparrow \phantom{0} \\ 45 \quad 400 \end{array}$$

d.  $258 + 443 = 701$   

$$\begin{array}{c} \phantom{2} \uparrow \phantom{0} \\ 42 \quad 401 \end{array}$$

e.  $408 + 303 = 711$   

$$408 \xrightarrow{+2} 410 \xrightarrow{+1} 411 \xrightarrow{+300} 711$$

f.  $478 + 303 = 781$   

$$\begin{array}{c} \phantom{4} \uparrow \phantom{0} \\ 2 \quad 301 \\ 480 + 301 = 781 \end{array}$$

g.  $478 + 323 = 801$   

$$\begin{array}{c} \phantom{4} \uparrow \phantom{0} \\ 2 \quad 321 \\ 480 + 321 \\ \phantom{4} \uparrow \phantom{0} \\ 20 \quad 301 \end{array}$$

**Exit Ticket (3 minutes)**

After the Student Debrief, instruct students to complete the Exit Ticket. A review of their work will help with assessing students' understanding of the concepts that were presented in today's lesson and planning more effectively for future lessons. The questions may be read aloud to the students.

Name \_\_\_\_\_

Date \_\_\_\_\_

1. Solve the following problems using place value disks, a place value chart, and vertical form.

a. $417 + 293$	b. $526 + 185$
c. $338 + 273$	d. $625 + 186$
e. $250 + 530$	f. $243 + 537$
g. $376 + 624$	h. $283 + 657$

2. Solve.

a.  $270 + 430 = \underline{\hspace{2cm}}$

b.  $260 + 440 = \underline{\hspace{2cm}}$

c.  $255 + 445 = \underline{\hspace{2cm}}$

d.  $258 + 443 = \underline{\hspace{2cm}}$

e.  $408 + 303 = \underline{\hspace{2cm}}$

f.  $478 + 303 = \underline{\hspace{2cm}}$

g.  $478 + 323 = \underline{\hspace{2cm}}$

Name \_\_\_\_\_

Date \_\_\_\_\_

Solve the following problems using your place value chart, place value disks, and vertical form. Bundle a ten or hundred, when necessary.

1.  $375 + 197$

2.  $184 + 338$

Name \_\_\_\_\_

Date \_\_\_\_\_

1. Solve the following problems using a place value chart, place value disks, and vertical form. Bundle a ten or hundred, when necessary.

a. $205 + 345$	b. $365 + 406$
c. $446 + 334$	d. $466 + 226$
e. $537 + 243$	f. $358 + 443$
g. $753 + 157$	h. $663 + 258$

2. Solve.

a.  $180 + 420 = \underline{\hspace{2cm}}$

b.  $190 + 430 = \underline{\hspace{2cm}}$

c.  $364 + 236 = \underline{\hspace{2cm}}$

d.  $275 + 435 = \underline{\hspace{2cm}}$

e.  $404 + 206 = \underline{\hspace{2cm}}$

f.  $440 + 260 = \underline{\hspace{2cm}}$

g.  $444 + 266 = \underline{\hspace{2cm}}$

## Lesson 10

**Objective:** Use math drawings to represent additions with up to two compositions and relate drawings to the addition algorithm.

### Suggested Lesson Structure

■ Application Problem	(6 minutes)
■ Fluency Practice	(13 minutes)
■ Concept Development	(31 minutes)
■ Student Debrief	(10 minutes)
<b>Total Time</b>	<b>(60 minutes)</b>

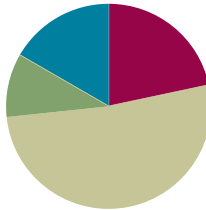

### Application Problem (6 minutes)

Benjie has 36 crayons. Ana has 12 fewer crayons than Benjie.

- How many crayons does Ana have?
- How many crayons do they have altogether?

Note: This problem is intended for guided practice to help students gain familiarity with the *compare with smaller unknown* problem type. The numbers are intentionally small to allow students to focus on the relationship between the numbers.

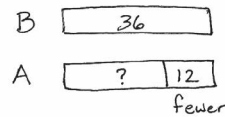

$$36 - 12 = \square$$

$$12 + \square = 36$$

Ana has 24 crayons.

$$\begin{array}{r} 36 + 24 = \square \\ \swarrow \quad \searrow \\ 50 \quad 10 \end{array}$$

They have 60 crayons altogether.

### Fluency Practice (13 minutes)

- Compensation (4 minutes)
- Sprint: Addition Crossing Tens (9 minutes)

### Compensation (4 minutes)

Note: This fluency activity reviews the mental math strategy of compensation. By making a multiple of 10, students solve a much simpler addition problem. Draw a number bond for the first problem on the board to help students visualize the decomposition.

T: (Write  $42 + 19 = \underline{\quad}$ .) Let's use a simplifying strategy to add. How much more does 19 need to make the next ten?

S: 1 more.

$$\begin{array}{r} 42 + 19 \\ \swarrow \quad \searrow \\ 41 \quad 1 \end{array}$$

$$41 + 20 = 61$$



T: Where can 19 get 1 more from?

S: From the 42.

T: Take 1 from 42 and give it to 19. Say the simplified number sentence with the answer.

S:  $41 + 20 = 61$ .

T:  $37 + 19$ . Say the simplified number sentence with the answer.

S:  $36 + 20 = 56$ .

Continue with the following possible sequence:  $29 + 23$ ,  $38 + 19$ ,  $32 + 19$ ,  $24 + 17$ , and  $34 + 19$ .

### Sprint: Addition Crossing Tens (9 minutes)

Materials: (S) Addition Crossing Tens Sprint

Note: This Sprint builds fluency with adding when crossing the next ten using mental strategies.

### Concept Development (31 minutes)

Materials: (S) Math journal or paper

As students learn to make math drawings like the chip model to represent the vertical form, it is important to emphasize precision in aligning digits in their proper place, drawing place value disks in clear 5-groups, and showing new groups below in the correct place.

#### Problem 1: $126 + 160$

T: (Write  $126 + 160$  vertically. Draw two long vertical lines, which serve as the place value chart, next to the vertical form. See image to the right.)

T: Let's show one part. How many hundreds in 126?

S: 1 hundred.

T: (Draw 1 hundred.) How many tens?

S: 2 tens. (Count tens as the teacher draws.)

T: How many ones?

S: 6 ones. (Count ones as the teacher draws.)

T: Let's count the first part to be sure our chip model is correct.

S: 100, 110, 120, 121, 122, 123, 124, 125, 126.

T: Now, let's show the other part. (Repeat the process to model 160.)



#### NOTES ON MULTIPLE MEANS OF ACTION AND EXPRESSION:

Since it is important to teach precision when drawing chips and aligning digits, students should use a pencil and paper, which allows for greater accuracy than a white board marker. As they work through each problem step-by-step, students can highlight each column on the place value chart and vertical form. Also, if a student continues to struggle with place value understanding, try highlighting the ones, tens, and hundreds columns in different colors.

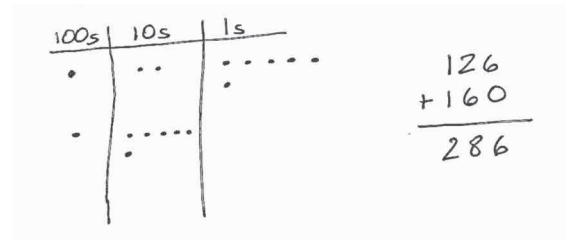

- T: Let's count the second part to check our model.
- S: 100, 110, 120, 130, 140, 150, 160.
- T: It's important that our chip model matches the problem we're solving.
- T: Now, let's solve the problem. 6 ones + 0 ones?
- S: 6 ones!
- T: Do we make a new ten?
- S: No!
- T: So, we write the number of ones, 6, below the line in the ones place.
- T: 2 tens + 6 tens?
- S: 8 tens!
- T: Do we make a new hundred?
- S: No!
- T: So, we write the number of tens, 8, below the line in the tens place.
- T: 1 hundred + 1 hundred?
- S: 2 hundreds!
- T: We write the number of hundreds, 2, below the line in the hundreds place. Read the problem with me.
- S:  $126 + 160 = 286$ .
- T: Did we need to bundle units in this problem? Why or why not? Discuss with your partner.
- S: 6 + 0 and 2 + 6 don't equal 10, and you only bundle when there are partners to ten or more. → The ones didn't make a ten, and the tens didn't make a hundred. → First, I looked in the ones column, and 6 plus 0 doesn't make a new ten. Then, I looked in the tens column, and 20 plus 60 isn't enough to make a new hundred.
- T: Now, explain to your partner how the chip model matches the vertical form. Explain your thinking using place value language.

### Problem 2: $326 + 167$

- T: Let's work through another problem together in your math journal. Turn your journal so the lines are already vertical on the page for easy setup. (Repeat the above process to model  $326 + 167$ .)
- T: Let's begin by adding the ones. Look at the vertical form and chip model. Tell your partner what you notice. How are they the same?
- S: They both show 6 and 7. → They show the same parts. → They both show 13 ones, but one is dots and the other is numbers.
- T: Aha! They show the same total, and that total is 13. What do we do now?
- S: Bundle 10 ones as 1 ten! → Compose a ten! → Rename 13 ones as 1 ten 3 ones!
- T: Excellent! Remember, what we do on the chip model, we do to the numbers. We composed a ten, so we circle the 10 ones and draw an arrow into the tens place, where we draw the new unit of 10. (See image to the right.)

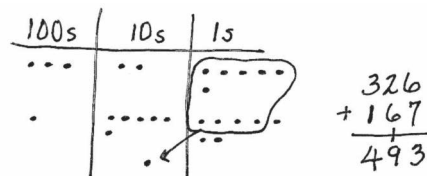

- T: Using vertical form, we show this new unit of 10 by writing a 1 on the line below the tens place. This way, we remember to add it in when we count the tens.
- T: We write 3 below the line in the ones place. When we look at the model, we see that there are 3 dots left.
- T: Now, let's add the tens. Remember to add the new unit. (Point to the model.) 2 tens + 6 tens + 1 ten is...?
- S: 9 tens!
- T: Did we make a new hundred?
- S: No!
- T: So, we write 9 tens below the line in the tens place.
- T: And now, let's add our hundreds. 3 hundreds + 1 hundred is...?
- S: 4 hundreds!
- T: We record the digit 4 below the line in the hundreds place. Read the entire problem.
- S:  $326 + 167 = 493$ .
- T: How does each step in the chip model match what we do in the vertical form? Talk with your partner. Explain your thinking using place value language.
- T: Now, it's your turn. Draw a model and use it to solve  $462 + 284$ . I'll walk around to see how it's going.



#### NOTES ON MULTIPLE MEANS OF ENGAGEMENT:

Use a simple rhythm or jingle to help students remember the key concept of composing a new unit. The following are examples:

- "Add your ones up first! Make a bundle if you can!"
- "Add your tens up next! Make a bundle if you can!"

Follow the above procedure to guide students as they write  $462 + 284$  vertically, model it, and solve. Remind students to be precise in lining up the digits and drawing their chips in neat 5-groups. Have them use place value language to explain each action they take on their model and how it is represented in the written addition.

Repeat the process for  $487 + 345$  with two renamings. Continue to support students working below grade level, but as students demonstrate proficiency, instruct them to work on the Problem Set independently.

### Problem Set (10 minutes)

Students should do their personal best to complete the Problem Set within the allotted 10 minutes. For some classes, it may be appropriate to modify the assignment by specifying which problems they work on first. Some problems do not specify a method for solving. Students should solve these problems using the RDW approach used for Application Problems.

### Student Debrief (10 minutes)

**Lesson Objective:** Use math drawings to represent additions with up to two compositions and relate drawings to the addition algorithm.

The Student Debrief is intended to invite reflection and active processing of the total lesson experience.

Invite students to review their solutions for the Problem Set. They should check work by comparing answers with a partner before going over answers as a class. Look for misconceptions or misunderstandings that can be addressed in the Student Debrief. Guide students in a conversation to debrief the Problem Set and process the lesson.

Any combination of the questions below may be used to lead the discussion.

- Explain to your partner how you solved Problem 1(a) using the chip model and the vertical form. How could you solve this problem differently using a simplifying strategy?
- For Problem 1(b), how did you know whether to bundle a new unit of 10 or 100?
- For Problem 1(c), where did you write the new ten or hundred in the vertical form? How did the vertical form match your chip model? How was this different from Problem 1(b)?
- What was interesting about Problem 1(d)? Could you have solved this problem mentally using your understanding of place value?
- Jade uses place value language to argue that the answer to Problem 2(a),  $546 + 192$ , is 6 hundreds, 13 tens, 8 ones. Sam says that it is 7 hundreds, 3 tens, 8 ones. Who is correct? How do you know?
- How did you solve Problem 2(a)? How did you change your place value disks to show Problem 2(b)? Did you compose a new unit of 10 or 100 in both problems?

**Exit Ticket (3 minutes)**

After the Student Debrief, instruct students to complete the Exit Ticket. A review of their work will help with assessing students' understanding of the concepts that were presented in today's lesson and planning more effectively for future lessons. The questions may be read aloud to the students.

Name EJ Date \_\_\_\_\_

1. Solve using vertical form, and draw chips on the place value chart. Bundle as needed.

hundreds	tens	ones	
●	●	●●●●●	$a. 117 + 170 = \underline{287}$  $\begin{array}{r} 117 \\ +170 \\ \hline 287 \end{array}$
●	●●●●●	●●	
2 hundreds	8 tens	7 ones	
hundreds	tens	ones	
●●	●	●●●●●	$b. 217 + 173 = \underline{390}$  $\begin{array}{r} 217 \\ +173 \\ \hline 390 \end{array}$
●	●●●●●	●●	
3 hundreds	9 tens	0 ones	
hundreds	tens	ones	
●●●	●●●●●	●	$c. 371 + 133 = \underline{504}$  $\begin{array}{r} 371 \\ +133 \\ \hline 504 \end{array}$
●	●●●	●●●	
5 hundreds	0 tens	4 ones	

d.  $504 + 269 = \underline{773}$

hundreds	tens	ones	
●●●●●	●●●●●	●●●●●	$\begin{array}{r} 504 \\ +269 \\ \hline 773 \end{array}$
●●	●●●●●	●●●●●	
7 hundreds	7 tens	3 ones	

2. Solve using vertical form, and draw chips on a place value chart. Bundle as needed.

a.  $546 + 192 = \underline{738}$

100's	10's	1's	
●●●●●	●●●●●	●●●●●	$\begin{array}{r} 546 \\ +192 \\ \hline 738 \end{array}$
●	●●●●●	●●	
7 hundreds	3 tens	8 ones	

b.  $546 + 275 = \underline{821}$

100's	10's	1's	
●●●●●	●●●●●	●●●●●	$\begin{array}{r} 546 \\ +275 \\ \hline 821 \end{array}$
●●	●●●●●	●●●●●	
8 hundreds	2 tens	1 one	

## A

Number Correct: \_\_\_\_\_

## Addition Crossing Tens

1.	$8 + 2 =$	
2.	$18 + 2 =$	
3.	$38 + 2 =$	
4.	$7 + 3 =$	
5.	$17 + 3 =$	
6.	$37 + 3 =$	
7.	$8 + 3 =$	
8.	$18 + 3 =$	
9.	$28 + 3 =$	
10.	$6 + 5 =$	
11.	$16 + 5 =$	
12.	$26 + 5 =$	
13.	$18 + 4 =$	
14.	$28 + 4 =$	
15.	$16 + 6 =$	
16.	$26 + 6 =$	
17.	$18 + 5 =$	
18.	$28 + 5 =$	
19.	$16 + 7 =$	
20.	$26 + 7 =$	
21.	$19 + 2 =$	
22.	$17 + 4 =$	

23.	$18 + 6 =$	
24.	$28 + 6 =$	
25.	$16 + 8 =$	
26.	$26 + 8 =$	
27.	$18 + 7 =$	
28.	$18 + 8 =$	
29.	$28 + 7 =$	
30.	$28 + 8 =$	
31.	$15 + 9 =$	
32.	$16 + 9 =$	
33.	$25 + 9 =$	
34.	$26 + 9 =$	
35.	$14 + 7 =$	
36.	$16 + 6 =$	
37.	$15 + 8 =$	
38.	$23 + 8 =$	
39.	$25 + 7 =$	
40.	$15 + 7 =$	
41.	$24 + 7 =$	
42.	$14 + 9 =$	
43.	$19 + 8 =$	
44.	$28 + 9 =$	

**B**

Number Correct: \_\_\_\_\_

Improvement: \_\_\_\_\_

## Addition Crossing Tens

1.	$9 + 1 =$	
2.	$19 + 1 =$	
3.	$39 + 1 =$	
4.	$6 + 4 =$	
5.	$16 + 4 =$	
6.	$36 + 4 =$	
7.	$9 + 2 =$	
8.	$19 + 2 =$	
9.	$29 + 2 =$	
10.	$7 + 4 =$	
11.	$17 + 4 =$	
12.	$27 + 4 =$	
13.	$19 + 3 =$	
14.	$29 + 3 =$	
15.	$17 + 5 =$	
16.	$27 + 5 =$	
17.	$19 + 4 =$	
18.	$29 + 4 =$	
19.	$17 + 6 =$	
20.	$27 + 6 =$	
21.	$18 + 3 =$	
22.	$26 + 5 =$	

23.	$19 + 5 =$	
24.	$29 + 5 =$	
25.	$17 + 7 =$	
26.	$27 + 7 =$	
27.	$19 + 6 =$	
28.	$19 + 7 =$	
29.	$29 + 6 =$	
30.	$29 + 7 =$	
31.	$17 + 8 =$	
32.	$17 + 9 =$	
33.	$27 + 8 =$	
34.	$27 + 9 =$	
35.	$12 + 9 =$	
36.	$14 + 8 =$	
37.	$16 + 7 =$	
38.	$28 + 6 =$	
39.	$26 + 8 =$	
40.	$24 + 8 =$	
41.	$13 + 8 =$	
42.	$24 + 9 =$	
43.	$29 + 8 =$	
44.	$18 + 9 =$	

Name \_\_\_\_\_

Date \_\_\_\_\_

1. Solve using vertical form, and draw chips on the place value chart. Bundle as needed.

hundreds	tens	ones

a.  $117 + 170 =$  \_\_\_\_\_

hundreds	tens	ones

b.  $217 + 173 =$  \_\_\_\_\_

hundreds	tens	ones

c.  $371 + 133 =$  \_\_\_\_\_

hundreds	tens	ones

d.  $504 + 269 = \underline{\hspace{2cm}}$

2. Solve using vertical form, and draw chips on a place value chart. Bundle as needed.

a.  $546 + 192 = \underline{\hspace{2cm}}$

b.  $546 + 275 = \underline{\hspace{2cm}}$



Name \_\_\_\_\_

Date \_\_\_\_\_

Solve using vertical form, and draw chips on a place value chart. Bundle as needed.

1.  $436 + 509 =$  \_\_\_\_\_

2.  $584 + 361 =$  \_\_\_\_\_

Name \_\_\_\_\_

Date \_\_\_\_\_

1. Solve using vertical form, and draw chips on the place value chart. Bundle as needed.

hundreds	tens	ones

a.  $124 + 260 =$  \_\_\_\_\_

hundreds	tens	ones

b.  $426 + 324 =$  \_\_\_\_\_

hundreds	tens	ones

c.  $362 + 243 =$  \_\_\_\_\_

hundreds	tens	ones

d.  $606 + 294 = \underline{\hspace{2cm}}$

2. Solve using vertical form, and draw chips on a place value chart. Bundle as needed.

a.  $372 + 118 = \underline{\hspace{2cm}}$

b.  $248 + 233 = \underline{\hspace{2cm}}$

## Lesson 11

**Objective:** Use math drawings to represent additions with up to two compositions and relate drawings to the addition algorithm.

### Suggested Lesson Structure

■ Application Problem	(5 minutes)
■ Fluency Practice	(10 minutes)
■ Concept Development	(35 minutes)
■ Student Debrief	(10 minutes)
<b>Total Time</b>	<b>(60 minutes)</b>

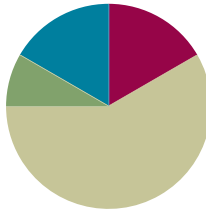

### Application Problem (5 minutes)

Mr. Arnold has a box of pencils. He passes out 27 pencils and has 45 left. How many pencils did Mr. Arnold have in the beginning?

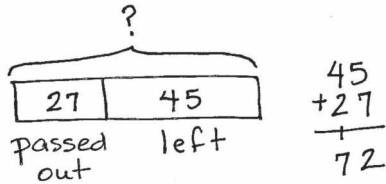

He had 72 pencils in the beginning.



#### NOTES ON MULTIPLE MEANS OF REPRESENTATION:

Since students are not expected to work the algorithm without place value charts and manipulatives in Grade 2, allow students to use place value disks to calculate the solution and explain their thinking. They can even use straws to represent the pencils in the Application Problem.

Note: This is a *take from with start unknown* problem type that reviews two-digit addition with one composition. Ask students to think about whether they know the parts or the whole and one part. This will guide them toward the recognition that the situation equation  $\_\_\_ - 27 = 45$  can be written as a solution equation:  $45 + 27 = \_\_\_$ .

### Fluency Practice (10 minutes)

- Place Value (3 minutes)
- Say Ten Counting (3 minutes)
- Compensation (4 minutes)

**Place Value (3 minutes)**

Note: This fluency activity reviews place value concepts from Module 3 to prepare students for today's lesson.

T: (Write 157 on the board.) Say the number in standard form.

S: 157.

T: Say 157 in unit form.

S: 1 hundred 5 tens 7 ones.

T: Say the unit form with only tens and ones.

S: 15 tens 7 ones.

T: Say the unit form with only hundreds and ones.

S: 1 hundred 57 ones.

T: Say 157 in expanded form.

S:  $100 + 50 + 7$ .

T: How many ones are in 157?

S: 157 ones.

T: How many tens are in 157?

S: 15 tens.

T: What digit is in the ones place?

S: 7.

T: What is the value of the digit in the tens place?

S: 50.

T: What is 1 less than 157?

S: 156.

T: What is 1 more than 157?

S: 158.

Continue with the following possible sequence: 10 less? 10 more? 100 more? and 100 less?

**Say Ten Counting (3 minutes)**

Note: Students practice making a ten in unit form to prepare for composing a ten on the place value chart in today's lesson.

T: What is 3 ones + 4 ones?

S: 7 ones.

T: 6 ones + 4 ones?

S: 10 ones.

T: What is another name for 10 ones?

S: 1 ten.

T: When we make a ten, let's say the number in tens and ones. Ready? 6 ones + 5 ones.

S: 1 ten 1 one.

Continue with the following possible sequence: 7 ones + 4 ones, 6 ones + 7 ones, 8 ones + 4 ones, 9 ones + 3 ones, 4 ones + 4 ones + 4 ones, and 5 ones + 3 ones + 4 ones.

### Compensation (4 minutes)

Note: This fluency activity reviews the mental math strategy compensation. By making a multiple of 10, students solve a much simpler addition problem. Draw a number bond for the first problem on the board to help students visualize the decomposition.

T: (Write  $54 + 29 = \underline{\quad}$ .) Let's use a mental math strategy to add. How much more does 29 need to make the next ten?

S: 1 more.

T: Where can 29 get 1 more?

S: From the 54.

T: Take 1 from 54 and give it to 29. Say the simplified number sentence with the answer.

S:  $53 + 30 = 83$ .

T:  $39 + 46$ . Say the simplified number sentence with the answer.

S:  $40 + 45 = 85$ .

$$\begin{array}{r} 54 + 29 \\ \swarrow \quad \searrow \\ 53 \quad 1 \\ 53 + 30 = 83 \end{array}$$

Continue with the following possible sequence:  $65 + 39$ ,  $79 + 46$ ,  $128 + 52$ ,  $145 + 38$ , and  $155 + 98$ .

### Concept Development (35 minutes)

Materials: (S) Math journal or paper

Note: Continue checking the accuracy of student drawings. Students must attend to the proper alignment of digits, drawing chips in clear 5-groups, and showing new groups below in the correct place. For this reason, the use of pencil and paper is more suitable than the use of a personal white board and marker.

#### Problem 1: $342 + 169$

T: Write  $342 + 169$  in vertical form on your paper.

T: Let's model it by drawing chips on a place value chart. I'll make a model on the board while you make yours. Whisper-count as you draw your model.

S: (Draw chip model.) 100, 200, 300, 310, 320, 330, 340, 341, 342. (Repeat the process to show 169.)

T: Use place value language to tell your partner how your model matches the vertical form.

S: 3 chips in the hundreds place is 300, 4 chips in the tens place equals 40, and 2 chips in the ones place is 2. → The model shows the Say Ten way: 3 hundreds 4 tens 2. → It's the same for 169, too. The model shows 1 hundred 6 tens 9.

T: I like the connection you made to Say Ten counting. Let's use that as we add the ones. 2 ones + 9 ones?

S: 11 ones.

T: What is 11 ones the Say Ten way?

S: 1 ten 1.

T: Tell your partner what to do first using the model and then using the algorithm.

S: We made a ten, so we circle it! → Bundle 10 ones, and draw an arrow with a new ten in the tens place. → Show the new unit on the line below the tens place, and write 1 below the line in the ones place.

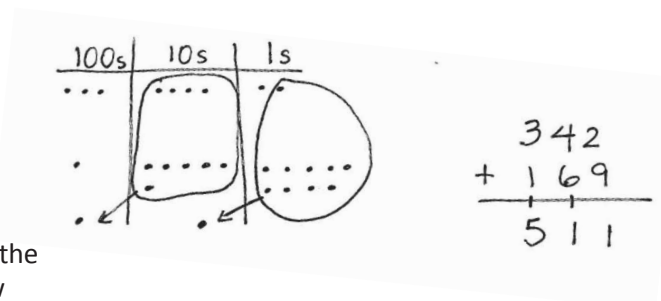

T: Yes! You composed a new unit of 10. You renamed 11 ones as 1 ten 1 one. Let's show that on our models and in vertical form.

S: (Circle 10 ones, draw an arrow to the tens place, and add a chip to show the new unit. Write 1 on the line below the tens place and write 1 below the line in the ones place.)

T: Partners, check each other's work to make sure it matches my chip model and the vertical form.

T: On the vertical form, you wrote a 1 on the line. Point to what the 1 stands for on your chip model. Who can tell us?

S: (Point to the new ten on the model.) It's the new ten we drew in the tens place because we bundled 10 ones.

T: Now, we add the tens. What is 4 tens + 6 tens + 1 ten?

S: 11 tens!

T: Tell your partner what to do next on the chip model and then in vertical form.

S: Circle 10 tens and draw an arrow and a chip to show the new hundred in the hundreds place. → Write 1 below the line in the tens place because there is 1 ten left over when you compose a hundred. → Write 1 on the line below the hundreds place because we have to add a new hundred.

T: Let's show this on our model and in vertical form.

S: (Show work.)

T: Partners, again, check each other's work to make sure it matches my chip model and the vertical form.

T: On the vertical form, we have a 1 on the line below the hundreds place. Point to what this 1 stands for on the model. Who can tell us?

S: It's the new hundred we got when we renamed 10 tens.

T: So, 11 tens became ...? The Say Ten way?

S: 1 hundred 1 ten!

T: Correct! Let's complete the problem. 3 hundreds + 1 hundred + 1 hundred is ...?

S: 5 hundreds!

T: We write the digit 5 below the line in the hundreds place. Let's read the entire problem.

S:  $342 + 169 = 511$ .

T: Talk with your partner: How does each step on the chip model match each step of the algorithm? (Pause as students share.)

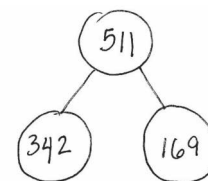

- T: Now, draw a number bond of this equation on your paper. Check your model with a partner, and explain how the model matches the equation.
- T: Who would like to explain the model you drew to the class?
- S: We add the parts to find the whole.  $\rightarrow$  342 and 169 are the parts, and 511 is the whole.  
 $\rightarrow$  I decomposed 511 as 342 and 169.
- T: Now, you're going to work through this next problem while I walk around and check to see how it's going. Show the problem as a number bond as well.

### Problem 2: $545 + 278$

Follow the procedure used in Problem 1 to guide students as they write  $545 + 278$  vertically, model it, and solve. Remind them to be precise in lining up the digits and drawing their chips in neat 5-groups. Have them use place value language to explain each action they take on their model and how it is represented in the vertical form.

Repeat the process for  $636 + 289$  and  $784 + 179$ . Continue to support students working below grade level. As students demonstrate proficiency, instruct them to work on the Problem Set independently.

### Problem Set (10 minutes)

Students should do their personal best to complete the Problem Set within the allotted 10 minutes. For some classes, it may be appropriate to modify the assignment by specifying which problems they work on first. Some problems do not specify a method for solving. Students should solve these problems using the RDW approach used for Application Problems.

### Student Debrief (10 minutes)

**Lesson Objective:** Use math drawings to represent additions with up to two compositions and relate drawings to the addition algorithm.

The Student Debrief is intended to invite reflection and active processing of the total lesson experience.

Invite students to review their solutions for the Problem Set. They should check work by comparing answers with a partner before going over answers as a class. Look for misconceptions or misunderstandings that can be addressed in the Student Debrief. Guide students in a conversation to debrief the Problem Set and process the lesson.

Any combination of the questions below may be used to lead the discussion.

- For Problem 1(a), use place value language to explain to your partner how your model matches the steps of the algorithm.

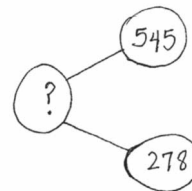

#### NOTES ON MULTIPLE MEANS OF ACTION AND EXPRESSION:

While it is encouraged that students learn and use new vocabulary during discussion, focus on their mathematical reasoning—their ability to make connections between the chip model and the vertical form, notice patterns when bundling, observe differences between models, and draw conclusions—rather than their accuracy in language.



- Think of the word *renaming*. A friend says that the Say Ten answer to Problem 1(b),  $424 + 288$ , is 6 hundreds 10 tens 12. How did you use bundling to rename the solution? What is your solution the Say Ten way?
- For Problem 1(c), where did you write the new ten or hundred in the vertical form? How did it match your chip model?
- Explain to your partner how you solved Problems 2(a) and 2(b). What significant differences do you notice about the chip model and the vertical form for these two problems?
- How does having two three-digit addends (as opposed to two-digit) change the way you model and solve the problem?
- What important math vocabulary have we used recently to talk about making a new unit? (**Compose, bundle, rename, change.**)

**Exit Ticket (3 minutes)**

After the Student Debrief, instruct students to complete the Exit Ticket. A review of their work will help with assessing students' understanding of the concepts that were presented in today's lesson and planning more effectively for future lessons. The questions may be read aloud to the students.

Name Daniel Date \_\_\_\_\_

1. Solve using vertical form, and draw chips on the place value chart. Bundle as needed.

hundreds	tens	ones
0	2	7
1	8	3
4	1	0

a.  $227 + 183 = 410$

$$\begin{array}{r} 227 \\ + 183 \\ \hline 410 \end{array}$$
  

hundreds	tens	ones
4	2	4
2	8	8
7	1	2

b.  $424 + 288 = 712$

$$\begin{array}{r} 424 \\ + 288 \\ \hline 712 \end{array}$$
  

hundreds	tens	ones
6	3	8
2	9	8
9	3	6

c.  $638 + 298 = 936$

$$\begin{array}{r} 638 \\ + 298 \\ \hline 936 \end{array}$$

d.  $648 + 289 = 937$

hundreds	tens	ones
6	4	8
2	8	9
9	3	7

2. Solve using vertical form, and draw chips on a place value chart. Bundle as needed.

a.  $307 + 187$

100's	10's	1's
3	0	7
1	8	7
4	1	4

$$\begin{array}{r} 307 \\ + 187 \\ \hline 494 \end{array}$$
  

b.  $398 + 207$

100's	10's	1's
3	9	8
2	0	7
6	0	5

$$\begin{array}{r} 398 \\ + 207 \\ \hline 605 \end{array}$$

Name \_\_\_\_\_

Date \_\_\_\_\_

1. Solve using vertical form, and draw chips on the place value chart. Bundle as needed.

hundreds	tens	ones

a.  $227 + 183 =$  \_\_\_\_\_

hundreds	tens	ones

b.  $424 + 288 =$  \_\_\_\_\_

hundreds	tens	ones

c.  $638 + 298 =$  \_\_\_\_\_

hundreds	tens	ones

d.  $648 + 289 =$  \_\_\_\_\_

2. Solve using vertical form, and draw chips on a place value chart. Bundle as needed.

a.  $307 + 187$

b.  $398 + 207$

Name \_\_\_\_\_

Date \_\_\_\_\_

Solve using vertical form, and draw chips on a place value chart. Bundle as needed.

1.  $267 + 356 =$  \_\_\_\_\_

2.  $623 + 279 =$  \_\_\_\_\_

Name \_\_\_\_\_

Date \_\_\_\_\_

1. Solve using vertical form, and draw chips on the place value chart. Bundle as needed.

hundreds	tens	ones

a.  $167 + 224 =$  \_\_\_\_\_

hundreds	tens	ones

b.  $518 + 245 =$  \_\_\_\_\_

hundreds	tens	ones

c.  $482 + 369 =$  \_\_\_\_\_

hundreds	tens	ones

d.  $638 + 298 =$  \_\_\_\_\_

2. Solve using vertical form, and draw chips on a place value chart. Bundle as needed.

a.  $456 + 378$

b.  $187 + 567$

## Lesson 12

**Objective:** Choose and explain solution strategies and record with a written addition method.

### Suggested Lesson Structure

■ Fluency Practice	(12 minutes)
■ Concept Development	(38 minutes)
■ Student Debrief	(10 minutes)
<b>Total Time</b>	<b>(60 minutes)</b>

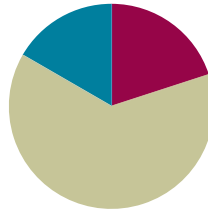

### Fluency Practice (12 minutes)

- Compensation (4 minutes)
- Sprint: Compensation Addition (8 minutes)

### Compensation (4 minutes)

Note: This fluency activity reviews compensation, the mental math strategy. By making a multiple of 10, students solve a much simpler addition problem. Draw a number bond for the first problem on the board to help students visualize the decomposition.

T: (Write  $61 + 99 = \underline{\quad}$ .) Let's use a mental math strategy to add.

How much more does 99 need to make 100?

S: 1 more.

T: Where can 99 get 1 more?

S: From the 61.

T: Take 1 from 61, and give it to 99. Say the simplified number sentence with the answer.

S:  $60 + 100 = 160$ .

T:  $99 + 46$ . Say the simplified number sentence with the answer.

S:  $100 + 45 = 145$ .

$$\begin{array}{r}
 61 + 99 \\
 \swarrow \searrow \\
 60 \quad 1 \\
 60 + 100 = 160
 \end{array}$$

Continue with the following possible sequence:  $99 + 38$ ,  $98 + 56$ ,  $47 + 98$ ,  $26 + 98$ ,  $54 + 99$ ,  $54 + 199$ , and  $73 + 199$ .

**Sprint: Compensation Addition (8 minutes)**

Materials: (S) Compensation Addition Sprint

Note: Students review compensation when adding to gain automaticity.

**Concept Development (38 minutes)**

Materials: (S) Place value disks (9 hundreds, 18 tens, 18 ones), personal white board

Note: The following lesson is designed to help facilitate a discussion about choosing the most efficient problem-solving strategies. Based on student needs and class ability, strategies other than those listed below may be used to solve. To allow for this in-depth discussion, the Application Problem has been omitted from today's lesson.

**Problem 1:  $374 + 210$** 

T: Turn and talk: What are some strategies you could use to solve this problem?

S: I can use mental math and place value strategies. → I can use the algorithm without place value disks. → I can use arrow notation.

Instruct students to choose a written strategy that they prefer and find most efficient. Encourage students to solve independently, and circulate to provide support. Then, invite a few students to share their work and explain how they applied the specific solution strategy. Remind students who used the algorithm to keep explanations brief.

S1: I used mental math and what I know about place value. I started at 374, and then in my head, I counted on 2 more hundreds to make 574. Then, I added a ten, and I had 584.

S2: I wrote the problem vertically and added ones, then tens, then hundreds under the line. It was easy to use the algorithm; I didn't even need to make a new ten or hundred.

S3: I used arrow notation to show the change as I added. I started with 374 and added 200, so I drew an arrow to 574. Then, I added on 10 more and drew an arrow to 584.

T: Turn and talk: Now that you've heard different solution strategies, which method do you prefer for this problem and why?

S: I like the arrow way best because 210 only has hundreds and tens, so it is easy to break apart and add on. → The chip model and place value disks take longer than using the arrow way. Plus, we don't have to bundle in this problem. → Now that we understand place value, it's easy to solve mentally.

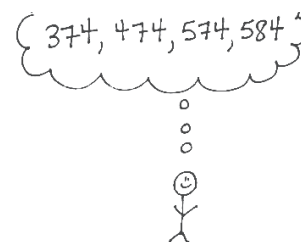
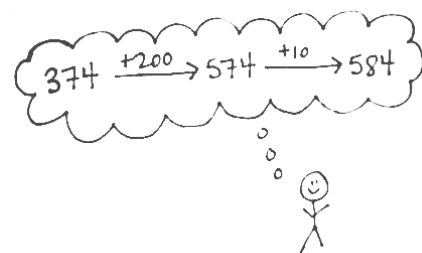
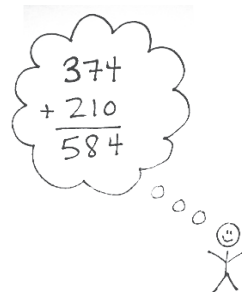

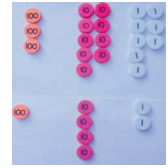

- T: I'm noticing that nobody suggested a number bond for this problem. Why not?
- S: None of the numbers are close to making the next hundred. → It's too hard to think of adding on to 374 to make 400. → I would have used a number bond if 374 had been 394.
- T: I like the way you're thinking! Let's take a look at another problem.

**Problem 2: 398 + 142**

- T: Turn and talk: What are some strategies you could use to solve this problem?
- S: Place value disks and the vertical form. → A number bond. → Arrow notation.

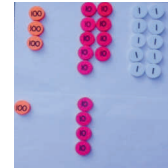

Again, instruct students to choose a written strategy that they prefer and find most efficient. Encourage them to solve independently, and circulate to provide support. Then, invite a few different students to share their work and explain how they applied the specific solution strategy. Again, remind students who used the written addition to keep explanations brief.

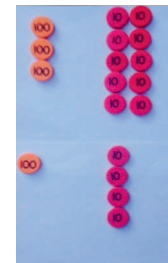

- S1: I counted the place value disks to show both parts. I started by adding my ones. When I made a ten, I exchanged 10 ones for 1 ten. Then, I added my tens. When I made a hundred, I exchanged 10 tens for a hundred. Then, I added my hundreds. The answer is 540.

- S2: I know that 398 is very close to 400, so I used a number bond. I decomposed 142 into 140 and 2. Then, I bonded the 2 with 398 to make 400, and 400 plus 140 equals 540.
- S3: I like arrow notation because you can start with 398 and first add 2, so 400, then add 100, then 40 more, and you have 540.

- T: Turn and talk: Which method do you think is best for this problem and why?
- S: Making a hundred is the easiest and quickest, especially since you only needed to add on 2. → Using the chip model is good, but it was faster to break apart the 142. → I prefer the arrow way because once you add 2 to make 400, it's easy to add a hundred and 4 tens.

**Problem 3: 287 + 234**

Note: For this problem, some students may choose to represent the problem using place value disks or drawings, while others may choose to solve using vertical form. Although the most efficient strategy will most likely be using vertical form, the Grade 2 expectation is not that students use the algorithm alone but that they use it in conjunction with a representation.

- T: Turn and talk: What are some strategies you could use to solve this problem?
- S: A place value disk drawing. → I would write just using the vertical form.

Students follow the same procedure as suggested in Problems 1 and 2. Since this problem does not lend itself to other simplifying strategies, invite one student, or maybe two, to share.

- S: My model shows that 11 ones becomes 1 ten 1 one. I showed that by writing 1 on the line below the tens place. 11 tens plus 1 ten is 12 tens, so I showed a new hundred, and then I wrote a 1 on the line below the hundreds place and a 2 below the line in the tens place. Then, I just added my hundred. So, the answer is 521.
- T: How was this the most efficient way to solve this problem? Why didn't you choose a simplifying strategy?
- S: Because solving using the arrow way would be too complicated. → The make a hundred strategy doesn't make it easier because the numbers are too far from the closest hundred. → Since you have to bundle twice, I like using the chips and the algorithm.
- T: Now, you're going to have the chance to analyze some student work and solve some problems by choosing a written strategy that works best for you.

### Problem Set (10 minutes)

Students should do their personal best to complete the Problem Set within the allotted 10 minutes. For some classes, it may be appropriate to modify the assignment by specifying which problems they work on first. Some problems do not specify a method for solving. Students should solve these problems using the RDW approach used for Application Problems.

### Student Debrief (10 minutes)

**Lesson Objective:** Choose and explain solution strategies and record with a written addition method.

The Student Debrief is intended to invite reflection and active processing of the total lesson experience.

Invite students to review their solutions for the Problem Set. They should check work by comparing answers with a partner before going over answers as a class. Look for misconceptions or misunderstandings that can be addressed in the Student Debrief. Guide students in a conversation to debrief the Problem Set and process the lesson.

Any combination of the questions below may be used to lead the discussion.

- Share with your partner: For Problem 1, which strategy was most efficient for Tracy to use? Why? Do you agree or disagree with your partner?
- Can you explain any alternate problem-solving strategies for Problem 1?



#### NOTES ON MULTIPLE MEANS OF ENGAGEMENT:

Writing about math can be daunting for some students.

- Provide oral options for informal assessment on the Problem Set rather than writing.
- Before they begin writing, ask students questions to probe.
- Support written responses on the Problem Set by providing a starter such as, "The number bond was the best strategy because ..."



#### NOTES ON MULTIPLE MEANS OF REPRESENTATION:

During the Debrief, invite students to share exemplary explanations with the whole class. Encourage students to model alternative, even creative, solutions. For example, for Problem 1 on the Problem Set ( $299 + 399$ ), a student might suggest adding hundreds and then subtracting 2: "If you add 1 to 299 and 399, you get  $300 + 400$  equals 700. Then, you have to subtract 2 from 700, so 698."

- To solve Problem 2(a), which strategy did you choose? Why?
- To solve Problem 2(b), which strategy did you choose? How did your understanding of place value help you solve this problem quickly?
- How did you solve Problem 2(c)? What made 2(c) more difficult to solve with a simplifying strategy? Could you have done so?

**Exit Ticket (3 minutes)**

After the Student Debrief, instruct students to complete the Exit Ticket. A review of their work will help with assessing students’ understanding of the concepts that were presented in today’s lesson and planning more effectively for future lessons. The questions may be read aloud to the students.

Name Nancy Date \_\_\_\_\_

1. Tracy solved the problem  $299 + 399$  four different ways.

$299 \xrightarrow{+1} 300 \xrightarrow{+98} 398 \xrightarrow{+300} 698$	$299 + 399$ $298 + 400 = 698$

Explain which strategy is most efficient for Tracy to use and why.

The most efficient way for Tracy to solve  $299 + 399$  is using a number bond to make a hundred. Both numbers are so close to the next hundred that it is easy and quick to take one and make a hundred. After making a hundred Tracy can solve mentally so that's very efficient.

2. Choose the best strategy and solve. Explain why you chose that strategy.

<p>a. <math>221 + 498</math></p> $219 \overset{2}{\nearrow}$ $219 + 500 = 719$	<p>Explanation:</p> <p><u>It's easy to add 500 to 219, so I used a number bond to change 498 to 500.</u></p>
<p>b. <math>467 + 200</math></p> $467 \xrightarrow{+200} 667$	<p>Explanation:</p> <p><u>I used the arrow way to show that I can add this problem in my head. Adding on 100's is easy!</u></p>
<p>c. <math>378 + 464</math></p>	<p>Explanation:</p> <p><u>I drew chips and solved using the vertical form because I saw there was a lot of renaming and I didn't want to make a mistake.</u></p>

## A

Number Correct: \_\_\_\_\_

## Compensation Addition

1.	$98 + 3 =$	
2.	$98 + 4 =$	
3.	$98 + 5 =$	
4.	$98 + 8 =$	
5.	$98 + 6 =$	
6.	$98 + 9 =$	
7.	$98 + 7 =$	
8.	$99 + 2 =$	
9.	$99 + 3 =$	
10.	$99 + 4 =$	
11.	$99 + 9 =$	
12.	$99 + 6 =$	
13.	$99 + 8 =$	
14.	$99 + 5 =$	
15.	$99 + 7 =$	
16.	$98 + 13 =$	
17.	$98 + 24 =$	
18.	$98 + 35 =$	
19.	$98 + 46 =$	
20.	$98 + 57 =$	
21.	$98 + 68 =$	
22.	$98 + 79 =$	

23.	$99 + 12 =$	
24.	$99 + 23 =$	
25.	$99 + 34 =$	
26.	$99 + 45 =$	
27.	$99 + 56 =$	
28.	$99 + 67 =$	
29.	$99 + 78 =$	
30.	$35 + 99 =$	
31.	$45 + 98 =$	
32.	$46 + 99 =$	
33.	$56 + 98 =$	
34.	$67 + 99 =$	
35.	$77 + 98 =$	
36.	$68 + 99 =$	
37.	$78 + 98 =$	
38.	$99 + 95 =$	
39.	$93 + 99 =$	
40.	$99 + 95 =$	
41.	$94 + 99 =$	
42.	$98 + 96 =$	
43.	$94 + 98 =$	
44.	$98 + 88 =$	

**B**

## Compensation Addition

Number Correct: \_\_\_\_\_

Improvement: \_\_\_\_\_

1.	$99 + 2 =$	
2.	$99 + 3 =$	
3.	$99 + 4 =$	
4.	$99 + 8 =$	
5.	$99 + 6 =$	
6.	$99 + 9 =$	
7.	$99 + 5 =$	
8.	$99 + 7 =$	
9.	$98 + 3 =$	
10.	$98 + 4 =$	
11.	$98 + 5 =$	
12.	$98 + 9 =$	
13.	$98 + 7 =$	
14.	$98 + 8 =$	
15.	$98 + 6 =$	
16.	$99 + 12 =$	
17.	$99 + 23 =$	
18.	$99 + 34 =$	
19.	$99 + 45 =$	
20.	$99 + 56 =$	
21.	$99 + 67 =$	
22.	$99 + 78 =$	

23.	$98 + 13 =$	
24.	$98 + 24 =$	
25.	$98 + 35 =$	
26.	$98 + 46 =$	
27.	$98 + 57 =$	
28.	$98 + 68 =$	
29.	$98 + 79 =$	
30.	$25 + 99 =$	
31.	$35 + 98 =$	
32.	$36 + 99 =$	
33.	$46 + 98 =$	
34.	$57 + 99 =$	
35.	$67 + 98 =$	
36.	$78 + 99 =$	
37.	$88 + 98 =$	
38.	$99 + 93 =$	
39.	$95 + 99 =$	
40.	$99 + 97 =$	
41.	$92 + 99 =$	
42.	$98 + 94 =$	
43.	$96 + 98 =$	
44.	$98 + 86 =$	

Name \_\_\_\_\_

Date \_\_\_\_\_

1. Tracy solved the problem  $299 + 399$  four different ways.

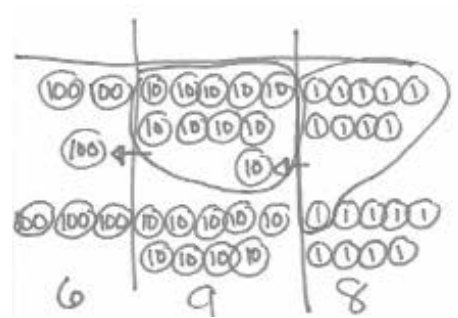
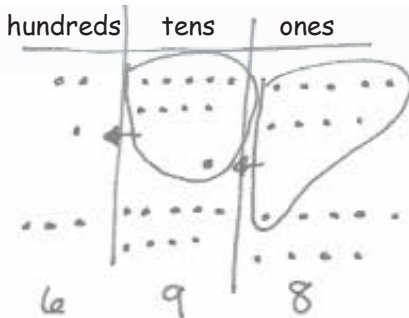
$  \begin{array}{r}  \phantom{2}99 \xrightarrow{+1} 300 \xrightarrow{+98} 398 \xrightarrow{+300} 698  \end{array}  $							
	<table style="width: 100%; border-collapse: collapse;"> <tr> <td style="border-right: 1px solid black; padding: 5px;">hundreds</td> <td style="border-right: 1px solid black; padding: 5px;">tens</td> <td style="padding: 5px;">ones</td> </tr> <tr> <td style="border-right: 1px solid black; text-align: center;">6</td> <td style="border-right: 1px solid black; text-align: center;">9</td> <td style="text-align: center;">8</td> </tr> </table> 	hundreds	tens	ones	6	9	8
hundreds	tens	ones					
6	9	8					

Explain which strategy is most efficient for Tracy to use and why.

---



---



---



---



---

2. Choose the best strategy and solve. Explain why you chose that strategy.

a. $221 + 498$	Explanation: <hr/> <hr/> <hr/> <hr/>
b. $467 + 200$	Explanation: <hr/> <hr/> <hr/> <hr/>
c. $378 + 464$	Explanation: <hr/> <hr/> <hr/> <hr/>

Name \_\_\_\_\_

Date \_\_\_\_\_

Choose the best strategy and solve. Explain why you chose that strategy.

1. $467 + 298$	Explanation: _____ _____ _____ _____
2. $300 + 524$	Explanation: _____ _____ _____ _____



Name \_\_\_\_\_

Date \_\_\_\_\_

1. Solve  $435 + 290$  using two different strategies.

a.	b.
----	----

- c. Explain which strategy would be easier and why.

---

---

---

---

2. Choose the best strategy and solve. Explain why you chose that strategy.

a. $299 + 458$	Explanation: <hr/> <hr/> <hr/> <hr/>
b. $733 + 210$	Explanation: <hr/> <hr/> <hr/> <hr/>
c. $295 + 466$	Explanation: <hr/> <hr/> <hr/> <hr/>

Name \_\_\_\_\_

Date \_\_\_\_\_

1. Solve each problem with a written strategy such as a tape diagram, a number bond, the arrow way, the vertical form, or chips on a place value chart.

a. $220 + 30 =$ _____	b. $200 + 380 =$ _____	c. $450 + 210 =$ _____
d. $490 + 12 =$ _____	e. _____ $= 380 + 220$	f. $750 - 590 =$ _____

2. Use the arrow way to solve.

a. $342 \xrightarrow{+100} \underline{\hspace{2cm}} \xrightarrow{+ \underline{\hspace{1cm}}} 542$	b. $600 \xrightarrow{- \underline{\hspace{1cm}}} 500 \xrightarrow{- \underline{\hspace{1cm}}} 490$	c. $\underline{\hspace{2cm}} \xrightarrow{+100} \underline{\hspace{2cm}} \xrightarrow{+10} 768$
d. $542 + 207 =$ _____	e. $430 + 361 =$ _____	f. $660 - 190 =$ _____

3. Solve each by drawing a model of a place value chart with chips and using the vertical form.

<p>a.</p> $328 + 259 = \underline{\hspace{2cm}}$	<p>b.</p> $575 + 345 = \underline{\hspace{2cm}}$
--	--

Circle *True* or *False* for each number sentence. Explain your thinking using pictures, words, or numbers.

<p>c.</p> $466 + 244 = 600 + 100$ <p><i>True / False</i></p>	<p>d.</p> $690 + 179 = 700 + 169$ <p><i>True / False</i></p>
--	--

<p>e.</p> $398 + 6 = 400 + 5$ <p><i>True / False</i></p>	<p>f.</p> $724 - 298 = 722 - 300$ <p><i>True / False</i></p>
--	--

4. Solve each problem with two written strategies such as a tape diagram, a number bond, the arrow way, the vertical form, or chips on a place value chart.

<p>a. <math>299 + 436 = \underline{\hspace{2cm}}</math></p>	
<p>b. <math>470 + 390 = \underline{\hspace{2cm}}</math></p>	

c.  $268 + 122 = \underline{\hspace{2cm}}$

d.  $330 - 190 = \underline{\hspace{2cm}}$

**Mid-Module Assessment Task  
Standards Addressed**

Topics A–B

**Use place value understanding and properties of operations to add and subtract.**

- Add and subtract within 1000, using concrete models or drawings and strategies based on place value, properties of operations, and/or the relationship between addition and subtraction; relate the strategy to a written method. Understand that in adding or subtracting three-digit numbers, one adds or subtracts hundreds and hundreds, tens and tens, ones and ones; and sometimes it is necessary to compose or decompose tens or hundreds.
- Mentally add 10 or 100 to a given number 100–900, and mentally subtract 10 or 100 from a given number 100–900.
- Explain why addition and subtraction strategies work, using place value and the properties of operations. (Explanations may be supported by drawings or objects.)

**Evaluating Student Learning Outcomes**

A Progression Toward Mastery is provided to describe steps that illuminate the gradually increasing understandings that students develop *on their way to proficiency*. In this chart, this progress is presented from left (Step 1) to right (Step 4). The learning goal for students is to achieve Step 4 mastery. These steps are meant to help teachers and students identify and celebrate what the students CAN do now and what they need to work on next.

A Progression Toward Mastery				
Assessment Task Item	STEP 1 Little evidence of reasoning without a correct answer.  (1 Point)	STEP 2 Evidence of some reasoning without a correct answer.  (2 Points)	STEP 3 Evidence of some reasoning with a correct answer or evidence of solid reasoning with an incorrect answer.  (3 Points)	STEP 4 Evidence of solid reasoning with a correct answer.  (4 Points)
1	The student provides one or two correct answers with correct strategies <i>or</i> provides up to six correct answers with no suggested strategies.	The student answers three or four parts correctly by using suggested strategies.	The student solves five out of six parts correctly by using suggested strategies.	The student correctly shows a strategy to solve <ul style="list-style-type: none"> <li>a. 250</li> <li>b. 580</li> <li>c. 660</li> <li>d. 502</li> <li>e. 600</li> <li>f. 160</li> </ul>
2	The student solves one or two out of six parts correctly by using the arrow way <i>or</i> solves all six parts correctly but does not use the arrow way.	The student solves three or four out of six parts correctly by using the arrow way <i>or</i> provides a correct answer for up to six parts but only uses the arrow way for three parts.	The student solves five out of six parts correctly by using the arrow way.	The student correctly models the arrow way and solves to find <ul style="list-style-type: none"> <li>a. 442, +100</li> <li>b. -100, -10</li> <li>c. 658, 758</li> <li>d. 749</li> <li>e. 791</li> <li>f. 470</li> </ul>





## A Progression Toward Mastery

3	The student solves one or two out of six parts correctly with or without a chip model and with or without providing a written explanation.	The student attempts to use a chip model to answer Parts (a) and (b) but arrives at an incorrect answer, <i>and</i> the student shows no explanation for Parts (c–f) but correctly answers true or false. OR The student provides some explanation for Parts (c–f), but the explanation is incorrect.	The student solves five out of six parts correctly by using a chip model for Parts (a) and (b) or explaining using pictures, words, or numbers for Parts (c–f).	The student correctly <ul style="list-style-type: none"> <li>▪ Models with place value chips and the vertical form to solve <ul style="list-style-type: none"> <li>a. 587</li> <li>b. 920</li> </ul> </li> <li>▪ Explains using pictures, words, or numbers to solve <ul style="list-style-type: none"> <li>c. False</li> <li>d. True</li> <li>e. False</li> <li>f. False</li> </ul> </li> </ul>
4	The student solves one problem correctly with or without a written strategy.	The student solves two problems correctly by using a strategy correctly. OR The student solves two or more problems correctly without any strategies shown.	The student solves all four problems correctly and shows six or seven correct strategies. OR The student solves three out of the four problems correctly with six correct strategies.	The student correctly uses two different strategies to solve <ul style="list-style-type: none"> <li>a. 735</li> <li>b. 860</li> <li>c. 390</li> <li>d. 140</li> </ul>

Name Henry

Date \_\_\_\_\_

1. Solve each problem with a written strategy such as a tape diagram, a number bond, the arrow way, the vertical form, or chips on a place value chart.

<p>a. <math>220 + 30 = \underline{250}</math></p> <p style="margin-left: 20px;"> <math>\begin{array}{c} \wedge \\ 200 \quad 20 \end{array}</math> </p> <p style="margin-left: 40px;"><math>20 + 30 = 50</math></p> <p style="margin-left: 40px;"><math>200 + 50 = 250</math></p>	<p>b. <math>200 + 380 = \underline{580}</math></p> <p style="margin-left: 40px;"><math>200 \xrightarrow{+300} 500 \xrightarrow{+80} 580</math></p>	<p>c. <math>450 + 210 = \underline{660}</math></p> <p style="margin-left: 40px;"> <math>\begin{array}{c} \wedge \\ 200 \quad 10 \end{array}</math> </p> <p style="margin-left: 40px;"><math>450 \xrightarrow{+200} 650 \xrightarrow{+10} 660</math></p>
<p>d. <math>490 + 12 = \underline{502}</math></p> <p style="margin-left: 40px;"> <math>\begin{array}{c} \wedge \\ 10 \quad 2 \end{array}</math> </p> <p style="margin-left: 40px;"><math>500 + 2 = 502</math></p>	<p>e. <math>\underline{600} = 380 + 220</math></p> <p style="margin-left: 40px;"> <math>\begin{array}{r} 380 \\ + 220 \\ \hline 600 \end{array}</math> </p>	<p>f. <math>750 - 590 = \underline{160}</math></p> <p style="margin-left: 40px;"> <math>\begin{array}{ c } \hline +10 \quad 750 \\ \hline \end{array}</math>  <math>\begin{array}{ c } \hline +10 \quad 590 \\ \hline \end{array}</math> </p> <p style="margin-left: 40px;"><math>760 - 600 = 160</math></p>

2. Use the arrow way to solve.

<p>a.</p> <p style="margin-left: 40px;"><math>342 \xrightarrow{+100} \underline{442} \xrightarrow{+100} 542</math></p>	<p>b.</p> <p style="margin-left: 40px;"><math>600 \xrightarrow{-100} 500 \xrightarrow{-10} 490</math></p>	<p>c.</p> <p style="margin-left: 40px;"><math>658 \xrightarrow{+100} \underline{758} \xrightarrow{+10} 768</math></p>
<p>d.</p> <p style="margin-left: 40px;"><math>542 + 207 = \underline{749}</math></p> <p style="margin-left: 40px;"><math>542 \xrightarrow{+200} 742 \xrightarrow{+7} 749</math></p>	<p>e.</p> <p style="margin-left: 40px;"><math>430 + 361 = \underline{791}</math></p> <p style="margin-left: 40px;"><math>430 \xrightarrow{+300} 730 \xrightarrow{+60} 790 \xrightarrow{+1} 791</math></p>	<p>f.</p> <p style="margin-left: 40px;"><math>660 - 190 = \underline{470}</math></p> <p style="margin-left: 40px;"><math>660 \xrightarrow{-100} 560 \xrightarrow{-60} 500 \xrightarrow{-30} 470</math></p>

3. Solve each by drawing a model of a place value chart with chips and using the vertical form.

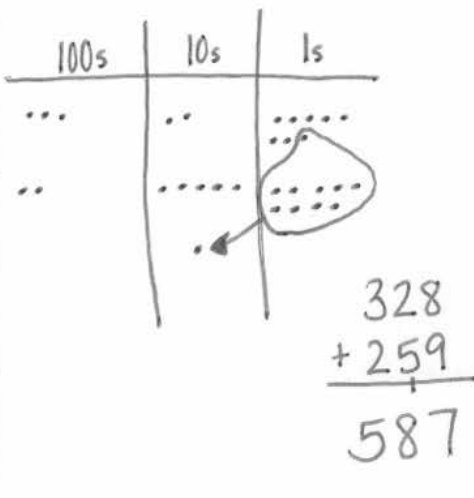
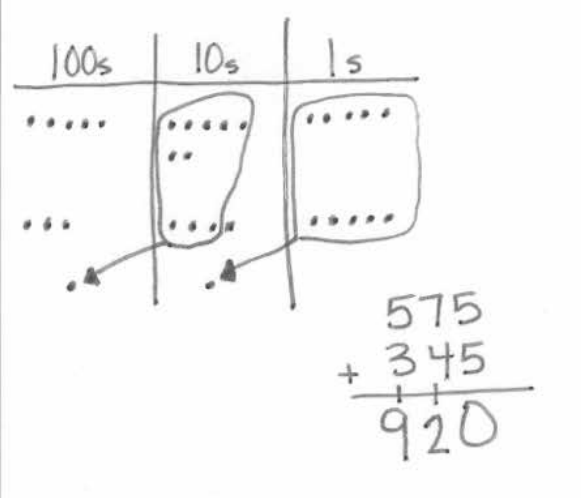
<p>a.</p> $328 + 259 = \underline{587}$ 	<p>b.</p> $575 + 345 = \underline{920}$ 
---	--

Circle *True* or *False* for each number sentence. Explain your thinking using pictures, words, or numbers.

<p>c.</p> $466 + 244 = 600 + 100$ <p style="text-align: center;"> <math>\begin{array}{ccccccc} &amp; \wedge &amp; &amp; \wedge &amp; &amp; \wedge &amp; \\ 400 &amp; 66 &amp; 44 &amp; 200 &amp; &amp; 700 &amp; \end{array}</math> </p> $400 + 110 + 200$ $710$ <p style="text-align: center;">True / <u>False</u></p>	<p>d.</p> $690 + 179 = 700 + 169$ <p style="text-align: center;"> <math>\begin{array}{ccc} &amp; \wedge &amp; \\ 10 &amp; 169 &amp; \end{array}</math> </p> $700 + 169$ <p style="text-align: center;">True / <u>False</u></p>
---	--

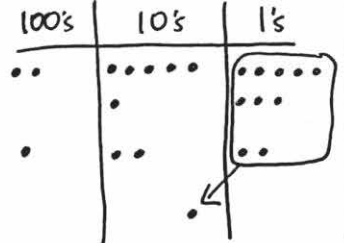

<p>c. <math>268 + 122 = \underline{390}</math></p> <p><math>268 \xrightarrow{+2} 270 \xrightarrow{+120} 390</math></p>	<p><math display="block">\begin{array}{r} 268 \\ + 122 \\ \hline 390 \end{array}</math></p> <p>100's   10's   1's</p> 
<p>d. <math>330 - 190 = \underline{140}</math></p> <p><math>\boxed{+10} \quad \boxed{330}</math></p> <p><math>\boxed{+10} \quad \boxed{190}</math></p> <p><math>340 - 200 = 140</math></p>	<p><math>330 \xrightarrow{-100} 230 \xrightarrow{-30} 200</math></p> <p><math>200 \xrightarrow{-60} \boxed{140}</math></p>



## Topic C

# Strategies for Decomposing Tens and Hundreds Within 1,000

- Focus Standards:**
- Add and subtract within 1000, using concrete models or drawings and strategies based on place value, properties of operations, and/or the relationship between addition and subtraction; relate the strategy to a written method. Understand that in adding or subtracting three-digit numbers, one adds or subtracts hundreds and hundreds, tens and tens, ones and ones; and sometimes it is necessary to compose or decompose tens or hundreds.
  - Explain why addition and subtraction strategies work, using place value and the properties of operations. (Explanations may be supported by drawings or objects.)

**Instructional Days:** 6

**Coherence -Links from:** G2–M4 Addition and Subtraction Within 200 with Word Problems to 100

**-Links to:** G3–M2 Place Value and Problem Solving with Units of Measure

G4–M1 Place Value, Rounding, and Algorithms for Addition and Subtraction

Topic C builds upon Module 4’s groundwork, which is now decomposing tens and hundreds within 1,000. In Lesson 13, students model decompositions with place value disks on their place value charts while simultaneously recording these changes in the vertical form. Students draw a magnifying glass around the minuend as they did in Module 4. They then ask familiar questions: *Do I have enough ones to subtract?* *Do I have enough tens?* When the answer is *no*, students exchange one of the larger units for ten of the smaller units. They record the change using the algorithm, following this procedure for each place on the place value chart.

In Lessons 14 and 15, students transition into creating math drawings, thus completing the move from concrete to pictorial representations. They follow the same procedure for decomposing numbers as in Lesson 13, but now, they use place value disk drawings (Lesson 14) and chip models (Lesson 15). Students continue to record changes in the vertical form as they relate their drawings to the algorithm, and they use place value reasoning and the properties of operations to solve problems with up to two decompositions (e.g.,  $547 - 168$ , as shown above).

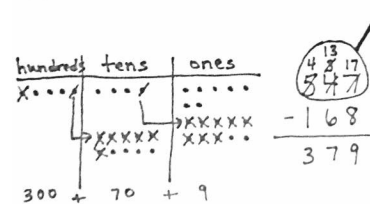
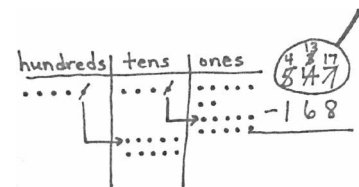

Lessons 16 and 17 focus on the special case of subtracting from multiples of 100 and numbers with zero in the tens place. Students recall the decomposition of 100 and 200 in Module 4 in one or two steps, using the same reasoning to subtract from larger numbers. For example, 300 can be decomposed into 2 hundreds and 10 tens, and then 1 ten is decomposed into 10 ones (two steps). Additionally, 300 can be renamed directly as 2 hundreds, 9 tens, and 10 ones (one step). In each case, students use math drawings to model the decompositions and relate them to the vertical form, step-by-step.

In Lesson 18, students work with three-digit subtraction problems, applying multiple strategies to solve. For example, with  $300 - 247$ , students learn that they can use compensation to subtract 1 from each number, making the equivalent expression  $299 - 246$ , which requires no renaming. Note that compensation is formally named in Module 5, although the concept was introduced in Module 4. Students may also use the related addition sentence,  $247 + \underline{\quad} = 300$ . The arrow notation is then used to solve, counting up 3 to 250, and then adding on 50, to find the answer of 53. For some problems, such as  $507 - 359$ , students may choose to draw a chip model and relate it to the algorithm, renaming 507 as 4 hundreds, 9 tens, 17 ones in one step. As students apply alternate methods, the emphasis is placed on students explaining and critiquing various strategies.

#### A Teaching Sequence Toward Mastery of Strategies for Decomposing Tens and Hundreds Within 1,000

**Objective 1:** Relate manipulative representations to the subtraction algorithm, and use addition to explain why the subtraction method works.  
(Lesson 13)

**Objective 2:** Use math drawings to represent subtraction with up to two decompositions, relate drawings to the algorithm, and use addition to explain why the subtraction method works.  
(Lessons 14–15)

**Objective 3:** Subtract from multiples of 100 and from numbers with zero in the tens place.  
(Lessons 16–17)

**Objective 4:** Apply and explain alternate methods for subtracting from multiples of 100 and from numbers with zero in the tens place.  
(Lesson 18)

## Lesson 13

**Objective:** Relate manipulative representations to the subtraction algorithm, and use addition to explain why the subtraction method works.

### Suggested Lesson Structure

■ Application Problem	(8 minutes)
■ Fluency Practice	(12 minutes)
■ Concept Development	(30 minutes)
■ Student Debrief	(10 minutes)
<b>Total Time</b>	<b>(60 minutes)</b>

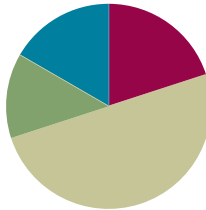

### Application Problem (8 minutes)

A fruit seller buys a carton of 90 apples. Finding that 18 of them are rotten, he throws them away. He sells 22 of the ones that are left on Monday. Now, how many apples does he have left to sell?

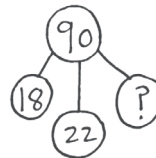
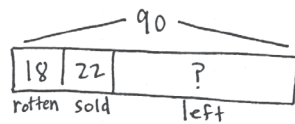

$$\begin{array}{r}
 18 + 22 \\
 \quad \quad \quad \wedge \\
 \quad \quad \quad 20 \\
 20 + 20 = 40 \\
 90 - 40 = 50
 \end{array}$$

The fruit seller has  
50 apples left to sell.

Note: This problem is designed for independent practice. Possibly encourage students to use the RDW process without dictating what to draw. Two-step problems challenge students to think through the first step before moving on to the second. The number sentences can help them to see and articulate the steps as well.

### Fluency Practice (12 minutes)

- Making the Next Ten (5 minutes)
- Making the Next Hundred (5 minutes)
- Subtracting Multiples of Hundreds and Tens (2 minutes)



**Making the Next Ten (5 minutes)**

Materials: (S) Personal white board

Note: This fluency activity reviews foundations that lead into today's lesson.

T: When I say  $9 + 4$ , you write  $10 + 3$ . Ready?  $9 + 4$ .

S:  $10 + 3$ .

T: Give the number sentence with the answer.

S:  $10 + 3 = 13$ .

T: Write the related addition sentence starting with  $9 + 4$ .

S:  $9 + 4 = 13$ .

Continue with the following possible sequence:  $19 + 4$ ,  $9 + 6$ ,  $19 + 6$ ,  $8 + 3$ ,  $18 + 3$ ,  $8 + 5$ ,  $18 + 5$ ,  $7 + 6$ ,  $17 + 6$ ,  $7 + 4$ ,  $17 + 4$ ,  $9 + 5$ ,  $19 + 5$ ,  $8 + 6$ ,  $18 + 6$ ,  $8 + 7$ , and  $17 + 8$ .

**Making the Next Hundred (5 minutes)**

Note: This fluency exercise reviews foundations that lead into today's lesson.

T: (Write 170 on the board.) Let's find the missing part to make the next hundred. What is the next hundred?

S: 200.

T: If I say 170, you say the number needed to make 200. Ready? 170.

S: 30.

T: Give the addition sentence.

S:  $170 + 30 = 200$ .

Continue with the following possible sequence: 190, 160, 260, 270, 370, 380, 580, 620, 720, 740, 940, 194, 196, 216, 214, and 224.

**Subtracting Multiples of Hundreds and Tens (2 minutes)**

Note: Students review subtracting multiples of tens and hundreds fluently in preparation for today's lesson.

T: What is 2 tens less than 130?

S: 110.

T: Give the subtraction sentence.

S:  $130 - 20 = 110$ .

T: What is 2 hundreds less than 350?

S: 150.

T: Give the subtraction sentence.

S:  $350 - 200 = 150$ .

Continue with the following possible sequence: 6 tens less than 150, 3 hundreds less than 550, 7 tens less than 250, 6 tens less than 340, and 4 hundreds less than 880.

### Concept Development (30 minutes)

Materials: (T) Place value disks (19 ones, 19 tens, 10 hundreds), unlabeled hundreds place value chart (Lesson 1 Template 2) (S) Place value disks (19 ones, 19 tens, and 10 hundreds), unlabeled hundreds place value chart (Lesson 1 Template 2), personal white board

#### Problem 1: 244 – 121

T: (Write  $244 - 121$  on the board.) Read this problem with me.

T/S: (Read the problem chorally.) 244 minus 121.

T: (Draw a blank number bond on the board.) How would you complete this number bond? Talk to a partner, and use part-whole language.

S: I would put 244 in the whole and 121 in one part. → I know 244 is the whole, since we are subtracting.

T: Great! What do we need to show on our place value charts? Talk to your neighbor.

S: We only show the whole when subtracting. → We are going to show 244 because it's the whole. → We are going to start with 244 and then take away 121.

T: Count in unit form as I place the disks. 1 hundred, 2 hundreds, 2 hundreds 1 ten, 2 hundreds 2 tens, 2 hundreds 3 tens, ..., 2 hundreds 4 tens 4 ones. (Place 2 hundreds, 4 tens, and 4 ones on the place value chart. Direct students to do the same.)

T: Today, as we solve subtraction problems, we are going to record our work vertically. (Write the problem in the vertical form.)

T: Remember our magnifying glasses! Let's draw an imaginary magnifying glass around 244, since that is the whole. (Draw the magnifying glass around 244.)

T: Like a detective, look carefully at each place to see if we have enough units to subtract moving from the smallest unit to the largest. (Give students a moment to check.)

T: Are we ready to subtract in the ones, tens, and hundreds?

S: Yes!

T: Go for it!

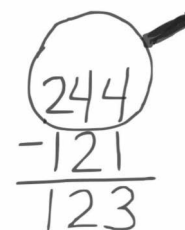
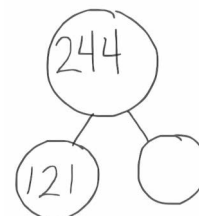

Have students remove 1 hundred, 2 tens, and 1 one from their place value charts and record the subtraction using the vertical form.

T: What is  $244 - 121$ ?

S: 123.

T: (Write 123 in the missing part in the number bond.)

T: Now, using our number bond, I bet it's easy for someone to come up with a related addition problem to check our answer. What problem should we write?

S:  $123 + 121$ .



#### NOTES ON MULTIPLE MEANS OF ACTION AND EXPRESSION:

Students may remark upon the sequence of the digits in 123. Encourage the excitement some may feel about finding the pattern in the numbers.

- T: Solve this problem on your personal white board, and turn it over when you have the answer.  
 T: What is the sum?  
 S: 244.  
 T: It worked!



**Problem 2: 244 – 125**

- T: Let's try another problem together. This time, I want you to record your work as I do mine. (Write  $244 - 125$  on the board in vertical form. Students do the same.)  
 T: What should we do first?  
 S: Find out if we need to unbundle. → Look at the numbers to see if we can solve mentally.  
 T: True! For this problem, let's solve using the algorithm. Show me the whole using your place value disks.  
 S: (Represent 244 using place value disks on their place value charts.)  
 T: (Draw the magnifying glass with enough space to write renaming, and instruct students to do the same.)  
 T: Okay, I'm looking closely. Where do we start?  
 S: Start in the ones column. → Check to see if you can subtract the ones.  
 T: Can we subtract 5 ones from 4 ones?  
 S: No!  
 T: What should we do?  
 S: Decompose a ten. → Rename a ten as ten ones. → Add 10 ones to 4 ones, so we have 14 ones.  
 T: Okay, go ahead and show that change using your place value disks. (Change a ten for 10 ones. Arrange them in 5-groups on the place value chart.)  
 T: Whatever we do to the place value disks, we must also do in the vertical form. How should we record unbundling a ten?  
 S: Cross out 4 tens, and write 3 tens above it. → Cross out the 4 in the ones place, and write 14 above it. → Change 4 tens to 3 tens and 4 ones to 14 ones.  
 T: Now, how many tens and ones do we have on our charts?  
 S: 3 tens 14 ones.  
 T: Look at each column closely. Tell me, are we ready to subtract?  
 S: Yes!  
 T: Then, let's subtract!



**NOTES ON  
 MULTIPLE MEANS  
 OF REPRESENTATION:**

Some students may benefit from recording a new group of 10 differently. For example, while most will likely cross out the 4 in the ones place and write a 14 above it, others may internalize the change by crossing out the 4 and writing  $10 + 4$  above it, then subtracting  $10 - 5$  and adding 4 to make 9 ones.



T: What is the answer to  $244 - 125$ ?

S: 119.

T: Check your answer with addition. Write a complete number bond. Does it work? (Pause to give students time to work.)

S: Yes!

### Problem 3: 312 – 186

T: Let's model another problem together. (Write  $312 - 186$  on the board in the vertical form. Allow students time to model and record the problem.) I'm going to follow what you do.

T: What is different about this problem?

S: We are taking away hundreds, too. → We are subtracting three digits. → You need to unbundle tens *and* hundreds in this problem.

T: Let's see if we need to unbundle. Do we have enough ones?

S: No!

T: Do we have enough tens?

S: No!

T: Let's unbundle to get ready to subtract. What should we do?

S: Change a ten for 10 ones. → Rename a ten as 10 ones. → Decompose a ten to make more ones.

T: (Change a ten for 10 ones.) Are we ready to subtract in the ones place?

T: How many ones do we have now?

S: 12.

T: How many tens are in the tens place?

S: None! → Zero!

T: Let's record this in the vertical form (shown to the right).

$$\begin{array}{r} 312 \\ - 186 \\ \hline \end{array}$$

$$\begin{array}{r} 012 \\ 312 \\ - 186 \\ \hline \end{array}$$

T: Are we ready to subtract in the tens place?

S: No!

T: What should we do now?

S: Unbundle a hundred! → Rename a hundred as 10 tens. → Break open a hundred to make 10 tens.

T: (Change a hundred for 10 tens.) How many tens do we have now?

S: 10.

T: How many hundreds?

S: 2.

T: Let's write this in the vertical form (shown above).

T: Are we ready to subtract 186 from 312?

S: Yes!

$$\begin{array}{r} 21012 \\ 312 \\ - 186 \\ \hline \end{array}$$

$$\begin{array}{r} 21012 \\ 312 \\ - 186 \\ \hline 126 \end{array}$$

Allow time for students to complete the subtraction independently, write a complete number bond, and check their work with addition.

## Problem Set (10 minutes)

Students should do their personal best to complete the Problem Set within the allotted 10 minutes. For some classes, it may be appropriate to modify the assignment by specifying which problems they work on first. Some problems do not specify a method for solving. Students should solve these problems using the RDW approach used for Application Problems.

## Student Debrief (10 minutes)

**Lesson Objective:** Relate manipulative representations to the subtraction algorithm, and use addition to explain why the subtraction method works.

The Student Debrief is intended to invite reflection and active processing of the total lesson experience.

Invite students to review their solutions for the Problem Set. They should check work by comparing answers with a partner before going over answers as a class. Look for misconceptions or misunderstandings that can be addressed in the Student Debrief. Guide students in a conversation to debrief the Problem Set and process the lesson.

Any combination of the questions below may be used to lead the discussion.

- What pattern did you notice in Problem 1(a) and (b)?
- For Problem 2(a–d), which problems were you able to solve mentally? Why?
- For Problem 2(e) and (f), how is it possible that both problems have the same difference?
- Explain to your partner how you used place value disks to solve Problem 2(g) and (h). How did your work with the place value disks match the vertical form?
- In Problem 2(i) and (j), did you change 1 hundred for 10 tens or 1 ten for 10 ones? How did you show the change using the algorithm?
- How did you use addition to prove that you subtracted correctly? Use part–whole language to explain your thinking.

Name Lindsay Date \_\_\_\_\_

1. Solve using mental math.

a.  $8 - 6 = 2$      $80 - 60 = 20$      $180 - 60 = 120$      $180 - 59 = 121$

b.  $6 - 3 = 3$      $60 - 30 = 30$      $760 - 30 = 730$      $760 - 28 = 732$

2. Solve using mental math or vertical form with place value disks. Check your work using addition.

a.  $138 - 17 = 121$

138	121
-17	+17
121	138

b.  $138 - 19 = 119$

138	119
-19	+19
119	138

c.  $445 - 35 = 410$

$45 - 35 = 10$   
 $445 - 35 = 410$   
 $410 + 35 = 445$

d.  $445 - 53 = 392$

445	392
-53	+53
392	445

e.  $863 - 170 = 693$

863	170
-170	+693
693	863

f.  $845 - 152 = 693$

$845 \xrightarrow{-100} 745 \xrightarrow{-40} 705 \xrightarrow{-10} 695$   
 $695 \xrightarrow{-2} 693$      $152$   
 $\quad\quad\quad + 693$   
 $\quad\quad\quad 845$

g.  $472 - 228 = 244$

472	228
-228	+244
244	472

h.  $418 - 274 = 144$

418	144
-274	+274
144	418

i.  $567 - 184 = 383$

567	184
-184	+383
383	567

j.  $567 - 148 = 419$

$567 \xrightarrow{-100} 467 \xrightarrow{-90} 427 \xrightarrow{-8} 419$

419	148
+419	567

**Exit Ticket (3 minutes)**

After the Student Debrief, instruct students to complete the Exit Ticket. A review of their work will help with assessing students' understanding of the concepts that were presented in today's lesson and planning more effectively for future lessons. The questions may be read aloud to the students.

Name \_\_\_\_\_

Date \_\_\_\_\_

1. Solve using mental math.

a.  $8 - 6 = \underline{\quad}$      $80 - 60 = \underline{\quad}$      $180 - 60 = \underline{\quad}$      $180 - 59 = \underline{\quad}$

b.  $6 - 3 = \underline{\quad}$      $60 - 30 = \underline{\quad}$      $760 - 30 = \underline{\quad}$      $760 - 28 = \underline{\quad}$

2. Solve using mental math or vertical form with place value disks. Check your work using addition.

a.  $138 - 17 = \underline{121}$

b.  $138 - 19 = \underline{\quad}$

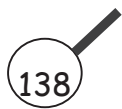

138	121
<u>-17</u>	<u>+ 17</u>
121	138

c.  $445 - 35 = \underline{\quad}$

d.  $445 - 53 = \underline{\quad}$

e.  $863 - 170 = \underline{\hspace{2cm}}$

f.  $845 - 152 = \underline{\hspace{2cm}}$

g.  $472 - 228 = \underline{\hspace{2cm}}$

h.  $418 - 274 = \underline{\hspace{2cm}}$

i.  $567 - 184 = \underline{\hspace{2cm}}$

j.  $567 - 148 = \underline{\hspace{2cm}}$



Name \_\_\_\_\_

Date \_\_\_\_\_

Solve using mental math or vertical form with place value disks. Check your work using addition.

1.  $378 - 117 =$  \_\_\_\_\_

2.  $378 - 119 =$  \_\_\_\_\_

3.  $853 - 433 =$  \_\_\_\_\_

4.  $853 - 548 =$  \_\_\_\_\_

Name \_\_\_\_\_

Date \_\_\_\_\_

1. Solve using mental math.

a.  $9 - 5 = \underline{\quad}$      $90 - 50 = \underline{\quad}$      $190 - 50 = \underline{\quad}$      $190 - 49 = \underline{\quad}$

b.  $7 - 4 = \underline{\quad}$      $70 - 40 = \underline{\quad}$      $370 - 40 = \underline{\quad}$      $370 - 39 = \underline{\quad}$

2. Solve using mental math or vertical form with place value disks. Check your work using addition.

a.  $153 - 31 = \underline{122}$

b.  $153 - 38 = \underline{\quad}$

$\begin{array}{r} 153 \\ -31 \\ \hline 122 \end{array}$	$\begin{array}{r} 122 \\ +31 \\ \hline 153 \end{array}$
---	---

c.  $362 - 49 = \underline{\quad}$

d.  $485 - 177 = \underline{\quad}$

e.  $753 - 290 = \underline{\hspace{2cm}}$

f.  $567 - 290 = \underline{\hspace{2cm}}$

g.  $873 - 428 = \underline{\hspace{2cm}}$

h.  $817 - 565 = \underline{\hspace{2cm}}$

i.  $973 - 681 = \underline{\hspace{2cm}}$

j.  $748 - 239 = \underline{\hspace{2cm}}$

3. Complete the number sentence modeled by place value disks.

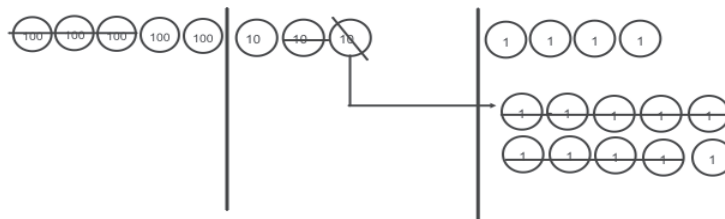

$$\underline{\hspace{2cm}} - \underline{\hspace{2cm}} = 215$$

## Lesson 14

**Objective:** Use math drawings to represent subtraction with up to two decompositions, relate drawings to the algorithm, and use addition to explain why the subtraction method works.

### Suggested Lesson Structure

■ Application Problem	(8 minutes)
■ Fluency Practice	(12 minutes)
■ Concept Development	(30 minutes)
■ Student Debrief	(10 minutes)
<b>Total Time</b>	<b>(60 minutes)</b>

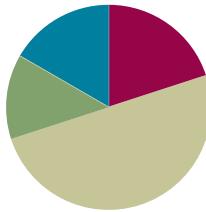

### Application Problem (8 minutes)

Brienne has 23 fewer pennies than Alonzo. Alonzo has 45 pennies.

- How many pennies does Brienne have?
- How many pennies do Alonzo and Brienne have altogether?

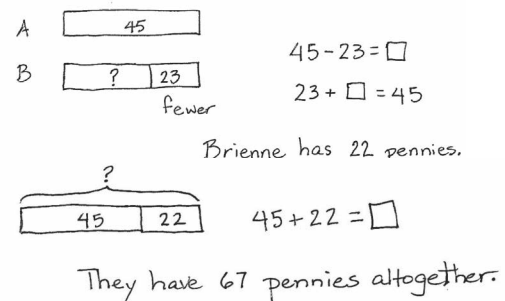

**Note:** This problem is intended for guided practice to help students gain familiarity with the *compare with smaller unknown* problem type. The numbers are intentionally small to allow students to focus on the relationship between the numbers. This also serves as a bridge to later work with two-step problems where the second step will not be scaffolded.

### Fluency Practice (12 minutes)

- Grade 2 Core Fluency Practice Sets (5 minutes)
- Using the Nearest Ten to Subtract (5 minutes)
- Subtract Common Units (2 minutes)

### Grade 2 Core Fluency Practice Sets (5 minutes)

Materials: (S) Grade 2 Core Fluency Practice Sets

**Note:** During Topic C and for the remainder of the year, each day's fluency activity includes an opportunity for review and mastery of the sums and differences with totals through 20 by means of the Core Fluency

Practice Sets or Sprints. Five options are provided in this lesson for the Core Fluency Practice Set, with Set A being the most simple addition fluency exercise of the grade to Set E being the most complex. Start all students on Set A. Keep a record of student progress so students can progress to more complex sets when they are ready.

Students complete as many problems as they can in 120 seconds. Reaching 100% accuracy and completion is recommended before moving to the next level. Collect any Fluency Practice Sets that have been completed within the 120 seconds, and check the answers. The next time Core Fluency Practice Sets are used, students who have successfully completed their set today can be provided with the next level.

Assign early finishers a counting pattern and start number. Celebrate improvement, as well as advancement. Students should be encouraged to compete with themselves rather than their peers. Discuss possible strategies to solve the problems with students. Notify caring adults of each student's progress.

### Using the Nearest Ten to Subtract (5 minutes)

Note: Students use bonds of 10 when subtracting as a mental strategy to help subtract fluently with larger numbers.

T: (Post  $16 - 9$  on the board.) Raise your hand when you know  $16 - 9$ .

S: 7.

T: (Write in the bond.)  $10 - 9$  is ...?

S: 1.

T:  $1 + 6$  is ...?

S: 7.

Continue with the following possible sequence:  $15 - 9$ ,  $13 - 8$ ,  $15 - 7$ ,  $16 - 7$ ,  $12 - 9$ ,  $13 - 7$ ,  $23 - 7$ ,  $25 - 7$ ,  $25 - 9$ ,  $26 - 9$ ,  $27 - 9$ ,  $27 - 19$ ,  $37 - 9$ ,  $37 - 19$ ,  $35 - 19$ ,  $45 - 19$ ,  $47 - 18$ , and  $48 - 29$ .

### Subtract Common Units (2 minutes)

Materials: (S) Personal white board

Note: Reviewing this mental math fluency exercise prepares students for understanding the importance of the subtraction algorithm.

T: (Project 77.) Say the number in unit form.

S: 7 tens 7 ones.

T: (Write  $77 - 22 = \underline{\quad}$ .) Say the subtraction sentence and answer in unit form.

S: 7 tens 7 ones  $-$  2 tens 2 ones  $=$  5 tens 5 ones.

T: Write the subtraction sentence on your board.

Repeat the process, and continue with the following possible sequence:  $88 - 33$ ,  $66 - 44$ ,  $266 - 44$ ,  $55 - 33$ , and  $555 - 33$ .

## Concept Development (30 minutes)

Materials: (S) Personal white board, math journal or paper

Note: In this lesson, students model subtraction by drawing place value disks. This serves as a bridge between their use of actual place value disks in Lesson 13 and the chip model drawings called for in Lesson 15. Personal white boards can be used in place of paper as students demonstrate precision in their drawings by aligning digits in their proper place and aligning place value disks in 5-groups.

### Problem 1: 584 – 147

- T: (Write  $584 - 147$  horizontally.) Would it be easy to solve this problem mentally?
- S: No, I can't keep all those numbers in my head. → It would be too confusing to solve mentally. → The algorithm would be the easiest way to solve.
- T: Ah! Part of your job as students is to know which tools make your work easier. Vertical form is an excellent choice for a problem like this.
- T: Rewrite the problem with me. (Write the problem vertically as students do the same.)
- T: Now, let's make a math drawing using place value disks because that will help us make sense of the numbers. First, tell your partner what you will draw.
- S: I'll draw 500, 80, and 4 with disks. → I'll draw 5 hundreds, 8 tens, and 4 ones.
- T: I like the way you used place value language. Let's draw our models. Whisper-count the total as you draw the place value disks.
- S: (Whisper-count and draw.) 100, 200, 300, ..., 584.
- T: Do we need to draw 147?
- S: No, it's part of 584. → We only draw the whole when we subtract. Then, we take away one part to show the other part.
- T: Excellent part-whole thinking!
- T: Let's set up the problem to subtract. We need to draw a...?
- S: Magnifying glass! (Draw a circle around 584 as students do the same.)
- T: Let's ask our questions. Are we ready to subtract in the ones place?
- S: No! 4 is less than 7.
- T: Where can we get some more ones?

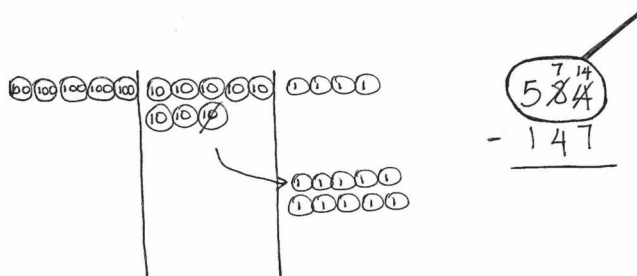

### NOTES ON MULTIPLE MEANS OF ACTION AND EXPRESSION:

Some students may answer *yes* to the question of solving the problem mentally. After all the lessons and practice with simplifying strategies, they may not need to write their work and may even resist having to do so. Encourage these students to follow along with the algorithm practice and use their mental math to check the vertical form, and vice versa.

- S: From the tens place. → Decompose a ten. → Rename 8 tens as 7 tens 10 ones.
- T: Let's show that on our model. (Cross off 1 ten, draw an arrow to the ones place, and draw 10 ones as students do the same.)
- T: Remember, as we change the model, we change the numbers in vertical form.
- T: Looking at our model, how many tens do we have now?
- S: 7 tens!
- T: So, we cross off the 8 tens and write 7 tens. (Record the change as students do the same.)
- T: How many ones do you see now?
- S: 14 ones!
- T: Let's cross off the 4 ones and write 14 ones. (Record the change as students do the same.)
- T: Look at the tens place. Are we ready to subtract in the tens place?
- S: Yes, because 7 is greater than 4.
- T: Are we ready to subtract in the hundreds place?
- S: Yes!
- T: Why?
- S: 5 hundreds is greater than 1 hundred!
- T: Now, we're ready to subtract. Talk with your partner. Take turns sharing how you'll show the subtraction on your model and using the algorithm.
- S: I cross off 7 ones and 7 ones are left, so I write 7 below the line in the ones place. → I cross off forty, and that leaves 30, so I write 3 below the line in the tens place. → 5 hundreds minus 1 hundred is 4 hundreds. I cross off 1 hundred, and 4 hundreds are left, so I write 4 below the line in the hundreds place.
- T: Read the complete number sentence.
- S:  $584 - 147$  equals 437.
- T: How can we prove our answer is correct?
- S: We can draw a number bond, because part + part = whole.
- T: It's true that part + part = whole, but how can we prove that the part we found is correct?
- S: Add the parts to see if they equal the whole. → Add  $147 + 437$  to see if it equals 584.
- T: Draw a model to solve  $147 + 437$ . Check your model and vertical form with your partner.



**NOTES ON  
MULTIPLE MEANS  
OF ENGAGEMENT:**

Some students may subtract starting in the hundreds place. Be prepared for that possibility, and encourage students to explain why that works.

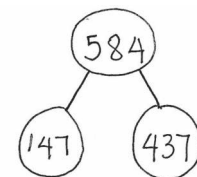

Circulate to assess and support students. Project student work, or call students to the board to show their model, vertical form, or number bond. Encourage students to use place value language to explain their work. Note that students began to work with chip models in Module 4, and those who are confident with this more abstract model and are able to explain it may choose to use it when they work independently.

- T: Who can explain why  $147 + 437$  helps us check  $584 - 147$ ?

S: I can show it on my chip model. You see the two parts, 147 and 437, and altogether, they show  $500 + 80 + 4$ , which is 584. → I can show it on my place value disk drawing. Inside 584, I can show 1 hundred, 4 tens, 7 ones, and also 4 hundreds, 3 tens, and 7 ones. → 7 ones + 7 ones equals 14 ones. That's 4 ones and a new ten. 4 tens + 3 tens + 1 ten is 8 tens. Then, 1 hundred + 4 hundreds is 5 hundreds. That makes 584.

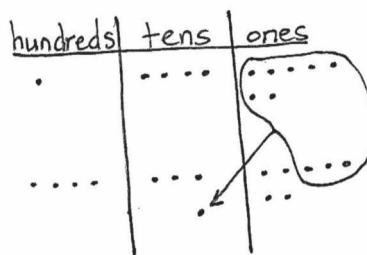

$$\begin{array}{r} 147 \\ + 437 \\ \hline 584 \end{array}$$

T: Those are very clear explanations using place value language. So, if  $584 - 147 = 437$ , then  $437 + 147 = 584$ . Is this true?

S: True!

### Problem 2: 637 – 253

Follow the above procedure to guide students as they write  $637 - 253$  vertically, model it with disks, and solve. Remind them to be precise in lining up the digits and drawing their place value disks in neat 5-groups. Have them use place value language to explain each action they take on their model and how it is represented using the algorithm. Continue to have them check their work with addition and to explain why this works.

Repeat the process for  $725 - 396$  and  $936 - 468$ . If students choose to solve  $725 - 396$  using mental math, be sure to invite them to explain their reasoning, either at this point in the lesson or during the Student Debrief.

Continue to support struggling students, but as they demonstrate proficiency, instruct them to work on the Problem Set independently.

### Problem Set (10 minutes)

Students should do their personal best to complete the Problem Set within the allotted 10 minutes. For some classes, it may be appropriate to modify the assignment by specifying which problems they work on first. Some problems do not specify a method for solving. Students should solve these problems using the RDW approach used for Application Problems.

### Student Debrief (10 minutes)

**Lesson Objective:** Use math drawings to represent subtraction with up to two decompositions, relate drawings to the algorithm, and use addition to explain why the subtraction method works.

The Student Debrief is intended to invite reflection and active processing of the total lesson experience.

Invite students to review their solutions for the Problem Set. They should check work by comparing answers with a partner before going over answers as a class. Look for misconceptions or misunderstandings that can be addressed in the Student Debrief. Guide students in a conversation to debrief the Problem Set and process the lesson.



Any combination of the questions below may be used to lead the discussion.

- Explain to your partner how you solved Problem 1(a). Did you have to unbundle a ten or hundred? Did you solve this problem mentally or with a simplifying strategy? How did you check your work?
- What significant differences do you notice about the way you changed your place value disks in Problem 1(b) versus 1(c)? How did you show the change using vertical form?
- For Problem 1(d), use place value language to explain to your partner how your model matches the vertical form. Compare how you checked your work.
- One student's answer for Problem 1(e),  $927 - 628$ , was 209. What mistake did he make in vertical form? How would the chip model have helped him figure out the correct answer?
- For Problem 2, explain to your partner why the statement is true. Using part-whole language, what do you know about the relationship between addition and subtraction?

**Exit Ticket (3 minutes)**

After the Student Debrief, instruct students to complete the Exit Ticket. A review of their work will help with assessing students' understanding of the concepts that were presented in today's lesson and planning more effectively for future lessons. The questions may be read aloud to the students.

Name Benny Date \_\_\_\_\_

1. Solve by drawing place value disks on a chart. Then, use addition to check your work.

<p>a. <math>469 - 170</math></p>	<p>Solve vertically or mentally:</p> $\begin{array}{r} 469 \\ -170 \\ \hline 299 \end{array}$	<p>Check:</p> $\begin{array}{r} 170 \\ +299 \\ \hline 469 \end{array}$
<p>b. <math>531 - 224</math></p>	<p>Solve vertically or mentally:</p> $\begin{array}{r} 531 \\ -224 \\ \hline 307 \end{array}$	<p>Check:</p> $\begin{array}{r} 224 \\ +307 \\ \hline 531 \end{array}$
<p>c. <math>618 - 229</math></p>	<p>Solve vertically or mentally:</p> $\begin{array}{r} 618 \\ -229 \\ \hline 389 \end{array}$	<p>Check:</p> $\begin{array}{r} 389 \\ +229 \\ \hline 618 \end{array}$

<p>d. <math>838 - 384</math></p>	<p>Solve vertically or mentally:</p> $\begin{array}{r} 838 \\ -384 \\ \hline 454 \end{array}$	<p>Check:</p> $\begin{array}{r} 384 \\ +454 \\ \hline 838 \end{array}$
<p>e. <math>927 - 628</math></p>	<p>Solve vertically or mentally:</p> $\begin{array}{r} 927 \\ -628 \\ \hline 299 \end{array}$	<p>Check:</p> $\begin{array}{r} 628 \\ +299 \\ \hline 927 \end{array}$

2. If  $561 - 387 = 174$ , then  $174 + 387 = 561$ . Explain why this statement is true using numbers, pictures, or words.

561 is the whole and 387 & 174 are the parts. So

$$\begin{aligned} 561 - 387 &= 174 \\ 561 - 174 &= 387 \\ 387 + 174 &= 561 \\ 174 + 387 &= 561 \end{aligned}$$

Name \_\_\_\_\_

Date \_\_\_\_\_

1.	$10 + 2 =$	21.	$2 + 9 =$
2.	$10 + 5 =$	22.	$4 + 8 =$
3.	$10 + 1 =$	23.	$5 + 9 =$
4.	$8 + 10 =$	24.	$6 + 6 =$
5.	$7 + 10 =$	25.	$7 + 5 =$
6.	$10 + 3 =$	26.	$5 + 8 =$
7.	$12 + 2 =$	27.	$8 + 3 =$
8.	$14 + 3 =$	28.	$6 + 8 =$
9.	$15 + 4 =$	29.	$4 + 6 =$
10.	$17 + 2 =$	30.	$7 + 6 =$
11.	$13 + 5 =$	31.	$7 + 4 =$
12.	$14 + 4 =$	32.	$7 + 9 =$
13.	$16 + 3 =$	33.	$7 + 7 =$
14.	$11 + 7 =$	34.	$8 + 6 =$
15.	$9 + 2 =$	35.	$6 + 9 =$
16.	$9 + 9 =$	36.	$8 + 5 =$
17.	$6 + 9 =$	37.	$4 + 7 =$
18.	$8 + 9 =$	38.	$3 + 9 =$
19.	$7 + 8 =$	39.	$8 + 6 =$
20.	$8 + 8 =$	40.	$9 + 4 =$

Name \_\_\_\_\_

Date \_\_\_\_\_

1.	$10 + 7 =$	21.	$5 + 8 =$
2.	$9 + 10 =$	22.	$6 + 7 =$
3.	$2 + 10 =$	23.	$\underline{\quad} + 4 = 12$
4.	$10 + 5 =$	24.	$\underline{\quad} + 7 = 13$
5.	$11 + 3 =$	25.	$6 + \underline{\quad} = 14$
6.	$12 + 4 =$	26.	$7 + \underline{\quad} = 14$
7.	$16 + 3 =$	27.	$\underline{\quad} = 9 + 8$
8.	$15 + \underline{\quad} = 19$	28.	$\underline{\quad} = 7 + 5$
9.	$18 + \underline{\quad} = 20$	29.	$\underline{\quad} = 4 + 8$
10.	$13 + 5 =$	30.	$3 + 9 =$
11.	$\underline{\quad} = 4 + 13$	31.	$6 + 7 =$
12.	$\underline{\quad} = 6 + 12$	32.	$8 + \underline{\quad} = 13$
13.	$\underline{\quad} = 14 + 6$	33.	$\underline{\quad} = 7 + 9$
14.	$9 + 3 =$	34.	$6 + 6 =$
15.	$7 + 9 =$	35.	$\underline{\quad} = 7 + 5$
16.	$\underline{\quad} + 4 = 11$	36.	$\underline{\quad} = 4 + 8$
17.	$\underline{\quad} + 6 = 13$	37.	$15 = 7 + \underline{\quad}$
18.	$\underline{\quad} + 5 = 12$	38.	$18 = \underline{\quad} + 9$
19.	$8 + 8 =$	39.	$16 = \underline{\quad} + 7$
20.	$6 + 9 =$	40.	$19 = 9 + \underline{\quad}$

Name \_\_\_\_\_

Date \_\_\_\_\_

1.	$15 - 5 =$	21.	$15 - 7 =$
2.	$16 - 6 =$	22.	$18 - 9 =$
3.	$17 - 10 =$	23.	$16 - 8 =$
4.	$12 - 10 =$	24.	$15 - 6 =$
5.	$13 - 3 =$	25.	$17 - 8 =$
6.	$11 - 10 =$	26.	$14 - 6 =$
7.	$19 - 9 =$	27.	$16 - 9 =$
8.	$20 - 10 =$	28.	$13 - 8 =$
9.	$14 - 4 =$	29.	$12 - 5 =$
10.	$18 - 11 =$	30.	$11 - 2 =$
11.	$11 - 2 =$	31.	$11 - 3 =$
12.	$12 - 3 =$	32.	$13 - 8 =$
13.	$14 - 2 =$	33.	$16 - 7 =$
14.	$13 - 4 =$	34.	$12 - 7 =$
15.	$11 - 3 =$	35.	$16 - 3 =$
16.	$12 - 4 =$	36.	$19 - 14 =$
17.	$13 - 2 =$	37.	$17 - 4 =$
18.	$14 - 5 =$	38.	$18 - 16 =$
19.	$11 - 4 =$	39.	$15 - 11 =$
20.	$12 - 5 =$	40.	$20 - 16 =$

Name \_\_\_\_\_

Date \_\_\_\_\_

1.	$12 - 2 =$	21.	$13 - 6 =$
2.	$15 - 10 =$	22.	$15 - 9 =$
3.	$17 - 11 =$	23.	$18 - 7 =$
4.	$12 - 10 =$	24.	$14 - 8 =$
5.	$18 - 12 =$	25.	$17 - 9 =$
6.	$16 - 13 =$	26.	$12 - 9 =$
7.	$19 - 9 =$	27.	$13 - 8 =$
8.	$20 - 10 =$	28.	$15 - 7 =$
9.	$14 - 12 =$	29.	$16 - 8 =$
10.	$13 - 3 =$	30.	$14 - 7 =$
11.	$\underline{\quad} = 11 - 2$	31.	$13 - 9 =$
12.	$\underline{\quad} = 13 - 2$	32.	$17 - 8 =$
13.	$\underline{\quad} = 12 - 3$	33.	$16 - 7 =$
14.	$\underline{\quad} = 11 - 4$	34.	$\underline{\quad} = 13 - 5$
15.	$\underline{\quad} = 13 - 4$	35.	$\underline{\quad} = 15 - 8$
16.	$\underline{\quad} = 14 - 4$	36.	$\underline{\quad} = 18 - 9$
17.	$\underline{\quad} = 11 - 3$	37.	$\underline{\quad} = 20 - 6$
18.	$15 - 6 =$	38.	$\underline{\quad} = 20 - 18$
19.	$16 - 8 =$	39.	$\underline{\quad} = 20 - 3$
20.	$12 - 5 =$	40.	$\underline{\quad} = 20 - 11$

Name \_\_\_\_\_

Date \_\_\_\_\_

1.	$12 + 2 =$	21.	$13 - 7 =$
2.	$14 + 5 =$	22.	$11 - 8 =$
3.	$18 + 2 =$	23.	$16 - 8 =$
4.	$11 + 7 =$	24.	$12 + 6 =$
5.	$9 + 6 =$	25.	$13 + 2 =$
6.	$7 + 8 =$	26.	$9 + 11 =$
7.	$4 + 7 =$	27.	$6 + 8 =$
8.	$13 - 6 =$	28.	$7 + 9 =$
9.	$12 - 8 =$	29.	$5 + 7 =$
10.	$17 - 9 =$	30.	$13 - 7 =$
11.	$14 - 6 =$	31.	$15 - 8 =$
12.	$16 - 7 =$	32.	$11 - 9 =$
13.	$8 + 8 =$	33.	$12 - 3 =$
14.	$7 + 6 =$	34.	$14 - 5 =$
15.	$4 + 9 =$	35.	$20 - 12 =$
16.	$5 + 7 =$	36.	$8 + 5 =$
17.	$6 + 5 =$	37.	$7 + 4 =$
18.	$13 - 8 =$	38.	$7 + 8 =$
19.	$16 - 9 =$	39.	$4 + 9 =$
20.	$14 - 8 =$	40.	$9 + 11 =$

Name \_\_\_\_\_

Date \_\_\_\_\_

1. Solve by drawing place value disks on a chart. Then, use addition to check your work.

a. $469 - 170$	Solve vertically or mentally:	Check:
b. $531 - 224$	Solve vertically or mentally:	Check:
c. $618 - 229$	Solve vertically or mentally:	Check:

d. $838 - 384$	Solve vertically or mentally:	Check:
e. $927 - 628$	Solve vertically or mentally:	Check:

2. If  $561 - 387 = 174$ , then  $174 + 387 = 561$ . Explain why this statement is true using numbers, pictures, or words.



Name \_\_\_\_\_

Date \_\_\_\_\_

Solve by drawing place value disks on a chart. Then, use addition to check your work.

1. $375 - 280$	Solve vertically or mentally:	Check:
2. $741 - 448$	Solve vertically or mentally:	Check:

Name \_\_\_\_\_

Date \_\_\_\_\_

1. Solve by drawing place value disks on a chart. Then, use addition to check your work.

a. $373 - 180$	Solve vertically or mentally:	Check:
b. $463 - 357$	Solve vertically or mentally:	Check:
c. $723 - 584$	Solve vertically or mentally:	Check:

d. $861 - 673$	Solve vertically or mentally:	Check:
e. $898 - 889$	Solve vertically or mentally:	Check:

2. If  $544 + 366 = 910$ , then  $910 - 544 = 366$ . Explain why this statement is true using numbers, pictures, or words.

## Lesson 15

**Objective:** Use math drawings to represent subtraction with up to two decompositions, relate drawings to the algorithm, and use addition to explain why the subtraction method works.

### Suggested Lesson Structure

■ Application Problem	(8 minutes)
■ Fluency Practice	(12 minutes)
■ Concept Development	(30 minutes)
■ Student Debrief	(10 minutes)
<b>Total Time</b>	<b>(60 minutes)</b>

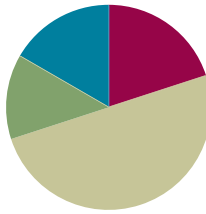

### Application Problem (8 minutes)

Catriona earned 16 more stickers than Peter. She earned 35 stickers. How many stickers did Peter earn?

MaryJo earned 47 stickers. How many more does Peter need to have the same amount as MaryJo?

Note: This *compare smaller unknown* problem is intended for guided practice. It is one of the four difficult subtypes of word problems in that the word *more* suggests addition, which would be an incorrect operation. This type of problem highlights the importance of drawing as a way to understand relationships in the problem. The question mark indicates the unknown because students recognize that they are looking for a missing part.

C	<input type="text" value="35"/>	
P	<input type="text" value="?"/>	16 more

$$35 - 16 = \square$$

$$16 + \square = 35$$

Peter earned 19 stickers.

MJ	<input type="text" value="47"/>	
P	<input type="text" value="19"/>	?

$$47 - 19 = \square$$

$$19 + \square = 47$$

Peter needs 28 more stickers.

### Fluency Practice (12 minutes)

- Grade 2 Core Fluency Practice Sets (5 minutes)
- Get to 10, 20, or 30 (4 minutes)
- Count by Ten or One with Dimes and Pennies (3 minutes)

**Grade 2 Core Fluency Practice Sets (5 minutes)**

Materials: (S) Grade 2 Core Fluency Practice Sets (Lesson 14 Core Fluency Practice Sets)

Note: During Topic C and for the remainder of the year, each day's fluency activity includes an opportunity for review and mastery of the sums and differences with totals through 20 by means of the Core Fluency Practice Sets or Sprints. In Lesson 14, Practice Sets are provided, and the process is explained in detail.

**Get to 10, 20, or 30 (4 minutes)**

Materials: (S) 3 dimes and 10 pennies

Note: This activity uses dimes and pennies to help students become familiar with coins, while simultaneously providing practice with missing addends to tens.

For the first two minutes:

- Step 1: Lay out 0–10 pennies in 5-group formation, and ask students to identify the amount shown (e.g., 9 cents).
- Step 2: Ask for the addition sentence to get to a dime (e.g., 9 cents + 1 cent = 1 dime).

For the next two minutes:

- Repeat Steps 1 and 2, and then add a dime and ask students to identify the amount shown (e.g., 1 dime 9 cents + 1 cent = 2 dimes).

**Count by Ten or One with Dimes and Pennies (3 minutes)**

Materials: (T) 10 dimes and 10 pennies

Note: This activity uses dimes and pennies as abstract representations of tens and ones to help students become familiar with coins, while simultaneously providing practice with counting forward and back by tens or ones.

- First minute: Place and take away dimes in a 5-group formation as students count along by ten.
- Second minute: Begin with 2 pennies. Ask how many ones there are. Instruct students to start at 2. Add and subtract 10 while placing and taking away dimes.
- Third minute: Begin with 2 dimes. Ask how many tens there are. Instruct students to begin at 20. Add and subtract 1 while placing and taking away pennies.

**Concept Development (30 minutes)**

Materials: (S) Personal white board, math journal or paper

Note: While this lesson focuses on relating chip models to the vertical form, guide students toward considering the relationship between the numbers before choosing a strategy to solve.

**Problem 1: 430 – 129**

- T: (Write  $430 - 129$  horizontally.) Talk with your partner: What do you notice about these numbers?
- S: 129 is close to 130, so it's going to be easy to solve mentally.  $\rightarrow$  If you don't even look at the hundreds, you see 30 minus 29.  $\rightarrow$  When I see 129, I think about making the next ten.
- T: I like your thinking! So, how would you solve this problem? (Allow students time to solve the problem.)
- T: Who would like to explain their solution?
- S:  $400 - 100$  is 300, and  $30 - 29$  is 1, so 301.  $\rightarrow$  I used the arrow way and counted on.  $129 + 1$  is 130, and  $130 + 300$  is 430, so the answer is 301.  $\rightarrow$  I added 1 to both numbers to make it easier, like  $431 - 130$ . So,  $400 - 100$  is 300, and  $31 - 30$  is 1, so 301.
- T: I like the way you noticed how close 129 is to 130, and how close 29 is to 30; I like the way you used that to help you solve the problem.
- T: So, we could solve this mentally, use a simplifying strategy, or use the algorithm. Is that true?
- S: True!
- T: It's important to think about the numbers before you decide which strategy to use.



**NOTES ON  
MULTIPLE MEANS  
OF ENGAGEMENT:**

Support oral responses by instructing students to write Problem 1 on their personal white board or paper. Since the hundreds may be distracting, have students underline or draw a box around the 30 in 430 and the 29 in 129. This focuses their attention on the nearest ten and prompts them to notice the opportunity to use a mental math strategy.

Solve  $560 - 258$  as a guided practice or proceed to Problem 2, depending on the needs of students.

**Problem 2: 941 – 587**

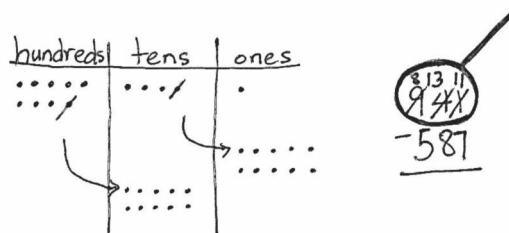
- T: (Write  $941 - 587$  horizontally.) How about this one? Mental math or the vertical form?
- S: The vertical form!
- T: Rewrite the problem with me. (Write the problem vertically as students do the same.)
- T: Today, let's make our math drawings using the chip model. I'll draw a model on the board while you draw your model at your desk. Whisper-count as you draw your chips.
- S: (Whisper-count and draw.) 100, 200, 300, ..., 941.
- T: Use place value language to tell your partner how your chip model matches vertical form.
- S: I can count my chips: 100, 200, 300, ..., 910, 920, ..., 941.  $\rightarrow$  I put 9 chips in the hundreds place and that's 900, 4 chips in the tens place and that's 40, and 1 chip in the ones place is 1.  $\rightarrow$  My model shows  $900 + 40 + 1$ . That's 941.
- T: Let's draw our magnifying glass and set this problem up to subtract! (Draw a circle around 941 as students do the same.)
- T: Look at your model. Are we ready to subtract the ones?
- S: No!



- T: Ask your partner: Where can we get some more ones?
- S: From the tens place. → Decompose a ten. → Rename 1 ten as 10 ones.
- T: Let's show that on our chip models. (Cross off 1 ten, draw an arrow to the ones place, and draw 10 ones as students do the same.)
- T: How many tens are in the tens place now?
- S: 3 tens.
- T: Show that in vertical form. Check your work with mine. (Cross off 4, and write 3 above the tens place as students do the same.)
- T: How many ones do you see on the model?
- S: 11 ones!
- T: Cross off 1 one, and write 11 ones. (Record the change as students do the same.)
- T: Look at the tens place. Are we ready to subtract in the tens?
- S: No!
- T: Why not?
- S: 3 tens is less than 8 tens. → 80 is greater than 30.
- T: Where can we get some more tens? Unbundle a...?
- S: Hundred!
- T: Let's show that on our chip models. (Cross off 1 hundred, draw an arrow to the tens place, and draw 10 tens as students do the same.)
- T: We need to record the change. How many hundreds do we see now?
- S: 8 hundreds!
- T: Cross off 9 hundreds, and write 8 hundreds. (Record as students do the same.)
- T: Look at the tens place on the model. How many tens do we see?
- S: 13 tens!
- T: Let's record that change as well. (Record as students do the same, changing 3 tens to 13 tens.)
- T: Are we completely ready to subtract?
- S: Yes! (Allow students time to complete the subtraction.)
- T: Talk with your partner. Take turns sharing how you showed the subtraction on your model and using the algorithm. (Allow time for students to share.)
- T: I heard some of you notice one of the advantages of getting the problem ready to subtract. You can subtract in any order!
- T: Read the complete number sentence.
- S:  $941 - 587 = 354$ .
- T: How can you prove that this statement is true?  
If  $941 - 587 = 354$ , then  $354 + 587 = 941$ .  
Discuss this with your partner.
- S: You can draw a number bond. → You could do the addition and see if it equals the whole. → If 354 is the missing part, when you add it to the other part, 587, it will equal the whole, 941.

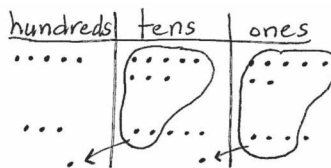

$$\begin{array}{r} 587 \\ + 354 \\ \hline 941 \end{array}$$

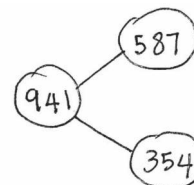

T: Please check the answer by drawing a chip model to add  $354 + 587$ . Check your model and addition with your partner. If you are correct, write the number bond for this problem.

Circulate to check for understanding and to support students working below grade level. Project student work or call students to the board to show the chip model, vertical form, and number bond. Encourage students to use place value language to explain their work.

### Problem 3: 624 – 225

Follow the previous procedure to guide students as they write  $624 - 225$  vertically, model it, and solve. Remind them to be precise in lining up the digits and drawing their chips in neat 5-groups. Encourage students to use place value language to explain each action they take on their model and how it is represented using vertical form. Instruct students to check their work with addition and to explain why this method works.

Repeat the process for  $756 - 374$  and  $817 - 758$ . Continue to support students working below grade level, but as they demonstrate proficiency, instruct them to work on the Problem Set independently.

### Problem Set (10 minutes)

Students should do their personal best to complete the Problem Set within the allotted 10 minutes. For some classes, it may be appropriate to modify the assignment by specifying which problems they work on first. Some problems do not specify a method for solving. Students should solve these problems using the RDW approach used for Application Problems.

### Student Debrief (10 minutes)

**Lesson Objective:** Use math drawings to represent subtraction with up to two decompositions, relate drawings to the algorithm, and use addition to explain why the subtraction method works.

The Student Debrief is intended to invite reflection and active processing of the total lesson experience.

Invite students to review their solutions for the Problem Set. They should check work by comparing answers with a partner before going over answers as a class. Look for misconceptions or misunderstandings that can be addressed in the Student Debrief. Guide students in a conversation to debrief the Problem Set and process the lesson.



#### NOTES ON MULTIPLE MEANS OF ACTION AND EXPRESSION:

As students work more independently, adjust the numbers in some problems to suit individual learners' levels:

- For students working below grade level, choose numbers that will only require one decomposition at a time rather than two.
- For students working above grade level, increase the numbers to the thousands to offer a challenge.

Name <u>Ty</u> Date _____		
1. Solve by drawing chips on the place value chart. Then, use addition to check your work.		
<p>a. <math>699 - 210</math></p>	<p>Solve vertically or mentally:</p> $\begin{array}{r} 699 \\ - 210 \\ \hline 489 \end{array}$	<p>Check:</p> $\begin{array}{r} 489 \\ + 210 \\ \hline 699 \end{array}$
<p>b. <math>758 - 387</math></p>	<p>Solve vertically or mentally:</p> $\begin{array}{r} 758 \\ - 387 \\ \hline 371 \end{array}$	<p>Check:</p> $\begin{array}{r} 387 \\ + 371 \\ \hline 758 \end{array}$
<p>c. <math>788 - 299</math></p>	<p>Solve vertically or mentally:</p> $\begin{array}{r} 788 \\ - 299 \\ \hline 489 \end{array}$	<p>Check:</p> $\begin{array}{r} 299 \\ + 489 \\ \hline 788 \end{array}$



Any combination of the questions below may be used to lead the discussion.

- For Problem 1(a), which strategy did you use to solve? Why? Why didn't you add one to 699 to make the hundred?
- For Problem 1(b), which strategy did you use to solve? Why? How did you know whether to unbundle a ten or hundred? How did you show the change in vertical form?
- For Problem 1(c), what is the most efficient way to solve this problem? Why? How was this problem different from Problem 1(a)? How did you check your work?
- For Problem 1(d), what number(s) did you draw on your place value chart? How did you show unbundling with your chips and in vertical form?
- For Problem 1(e), how can you tell right away if you will need to decompose a ten or hundred?
- What important math vocabulary have we used to talk about breaking apart a larger unit into smaller units? (**Decompose, rename, unbundle, change.**)

<p>d. <math>821 - 523</math></p>	<p>Solve vertically or mentally:</p> $\begin{array}{r} 821 - 500 \rightarrow 321 \\ 321 - 21 \rightarrow 300 \\ 300 - 2 \rightarrow 298 \end{array}$	<p>Check:</p> $\begin{array}{r} 298 \\ + 523 \\ \hline 821 \end{array}$
<p>e. <math>913 - 558</math></p>	<p>Solve vertically or mentally:</p> $\begin{array}{r} 913 \\ - 558 \\ \hline 355 \end{array}$	<p>Check:</p> $\begin{array}{r} 355 \\ + 558 \\ \hline 913 \end{array}$

2. Complete all of the *if...then* statements. Draw a number bond to represent the related facts.

a. If  $762 - 589 = 173$ , then  $173 + 589 = 762$ .

b. If  $631 - 358 = 273$ , then  $358 + 273 = 631$ .

### Exit Ticket (3 minutes)

After the Student Debrief, instruct students to complete the Exit Ticket. A review of their work will help with assessing students' understanding of the concepts that were presented in today's lesson and planning more effectively for future lessons. The questions may be read aloud to the students.

Name \_\_\_\_\_

Date \_\_\_\_\_

1. Solve by drawing chips on the place value chart. Then, use addition to check your work.

<p>a. <math>699 - 210</math></p> <table border="1" style="width: 100%; text-align: center;"> <tr> <td style="width: 33%;">hundreds</td> <td style="width: 33%;">tens</td> <td style="width: 33%;">ones</td> </tr> <tr> <td style="height: 150px;"></td> <td></td> <td></td> </tr> </table>	hundreds	tens	ones				Solve vertically or mentally:	Check:
hundreds	tens	ones						
<p>b. <math>758 - 387</math></p> <table border="1" style="width: 100%; text-align: center;"> <tr> <td style="width: 33%;">hundreds</td> <td style="width: 33%;">tens</td> <td style="width: 33%;">ones</td> </tr> <tr> <td style="height: 150px;"></td> <td></td> <td></td> </tr> </table>	hundreds	tens	ones				Solve vertically or mentally:	Check:
hundreds	tens	ones						
<p>c. <math>788 - 299</math></p> <table border="1" style="width: 100%; text-align: center;"> <tr> <td style="width: 33%;">hundreds</td> <td style="width: 33%;">tens</td> <td style="width: 33%;">ones</td> </tr> <tr> <td style="height: 150px;"></td> <td></td> <td></td> </tr> </table>	hundreds	tens	ones				Solve vertically or mentally:	Check:
hundreds	tens	ones						

<p>d. <math>821 - 523</math></p> <table border="1" style="width: 100%; border-collapse: collapse;"> <tr> <td style="width: 33%; text-align: center; padding: 5px;">hundreds</td> <td style="width: 33%; text-align: center; padding: 5px;">tens</td> <td style="width: 33%; text-align: center; padding: 5px;">ones</td> </tr> <tr> <td style="border-top: 1px solid black; border-bottom: 1px solid black; height: 100px;"></td> <td style="border-top: 1px solid black; border-bottom: 1px solid black; height: 100px;"></td> <td style="border-top: 1px solid black; border-bottom: 1px solid black; height: 100px;"></td> </tr> </table>	hundreds	tens	ones				Solve vertically or mentally:	Check:
hundreds	tens	ones						
<p>e. <math>913 - 558</math></p> <table border="1" style="width: 100%; border-collapse: collapse;"> <tr> <td style="width: 33%; text-align: center; padding: 5px;">hundreds</td> <td style="width: 33%; text-align: center; padding: 5px;">tens</td> <td style="width: 33%; text-align: center; padding: 5px;">ones</td> </tr> <tr> <td style="border-top: 1px solid black; border-bottom: 1px solid black; height: 100px;"></td> <td style="border-top: 1px solid black; border-bottom: 1px solid black; height: 100px;"></td> <td style="border-top: 1px solid black; border-bottom: 1px solid black; height: 100px;"></td> </tr> </table>	hundreds	tens	ones				Solve vertically or mentally:	Check:
hundreds	tens	ones						

2. Complete all of the *if...then* statements. Draw a number bond to represent the related facts.

a. If  $762 - \underline{\hspace{2cm}} = 173$ , then  $173 + 589 = \underline{\hspace{2cm}}$ .

b. If  $631 - \underline{\hspace{2cm}} = 273$ , then  $\underline{\hspace{2cm}} + 273 = 631$ .

Name \_\_\_\_\_

Date \_\_\_\_\_

Solve by drawing chips on the place value chart. Then, use addition to check your work.

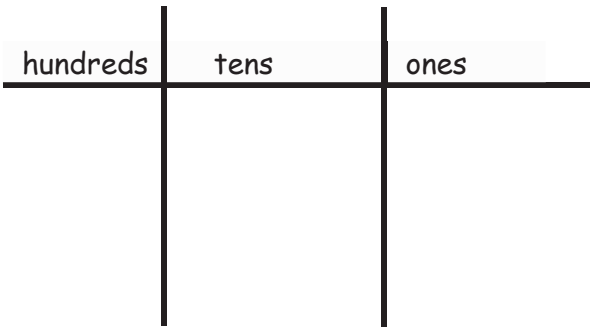
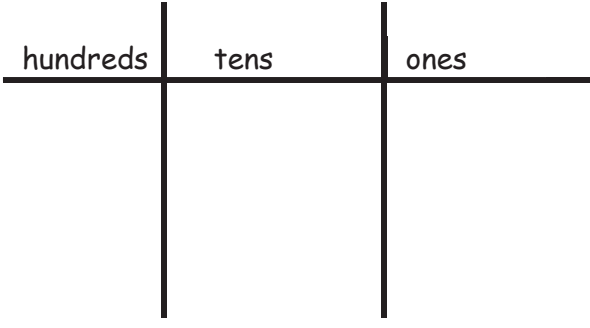
1. $583 - 327$  <p>A place value chart with three columns labeled 'hundreds', 'tens', and 'ones' from left to right. The chart is divided by a horizontal line and two vertical lines. The 'hundreds' column is shaded light blue, the 'tens' column is shaded light green, and the 'ones' column is shaded light purple.</p>	Solve vertically or mentally:	Check:
2. $721 - 485$  <p>A place value chart with three columns labeled 'hundreds', 'tens', and 'ones' from left to right. The chart is divided by a horizontal line and two vertical lines.</p>	Solve vertically or mentally:	Check:

Name \_\_\_\_\_

Date \_\_\_\_\_

1. Solve by drawing chips on the place value chart. Then, use addition to check your work.

<p>a. <math>800 - 675</math></p> <table border="1" style="margin-left: auto; margin-right: auto;"> <thead> <tr> <th style="padding: 5px;">hundreds</th> <th style="padding: 5px;">tens</th> <th style="padding: 5px;">ones</th> </tr> </thead> <tbody> <tr> <td style="height: 150px;"></td> <td></td> <td></td> </tr> </tbody> </table>	hundreds	tens	ones				Solve vertically or mentally:	Check:
hundreds	tens	ones						
<p>b. <math>742 - 495</math></p> <table border="1" style="margin-left: auto; margin-right: auto;"> <thead> <tr> <th style="padding: 5px;">hundreds</th> <th style="padding: 5px;">tens</th> <th style="padding: 5px;">ones</th> </tr> </thead> <tbody> <tr> <td style="height: 150px;"></td> <td></td> <td></td> </tr> </tbody> </table>	hundreds	tens	ones				Solve vertically or mentally:	Check:
hundreds	tens	ones						
<p>c. <math>657 - 290</math></p> <table border="1" style="margin-left: auto; margin-right: auto;"> <thead> <tr> <th style="padding: 5px;">hundreds</th> <th style="padding: 5px;">tens</th> <th style="padding: 5px;">ones</th> </tr> </thead> <tbody> <tr> <td style="height: 150px;"></td> <td></td> <td></td> </tr> </tbody> </table>	hundreds	tens	ones				Solve vertically or mentally:	Check:
hundreds	tens	ones						

<p>d. <math>877 - 398</math></p> <table border="1" style="width: 100%; border-collapse: collapse;"> <thead> <tr> <th style="width: 33%; text-align: center;">hundreds</th> <th style="width: 33%; text-align: center;">tens</th> <th style="width: 33%; text-align: center;">ones</th> </tr> </thead> <tbody> <tr> <td style="height: 150px;"></td> <td></td> <td></td> </tr> </tbody> </table>	hundreds	tens	ones				Solve vertically or mentally:	Check:
hundreds	tens	ones						
<p>e. <math>941 - 628</math></p> <table border="1" style="width: 100%; border-collapse: collapse;"> <thead> <tr> <th style="width: 33%; text-align: center;">hundreds</th> <th style="width: 33%; text-align: center;">tens</th> <th style="width: 33%; text-align: center;">ones</th> </tr> </thead> <tbody> <tr> <td style="height: 150px;"></td> <td></td> <td></td> </tr> </tbody> </table>	hundreds	tens	ones				Solve vertically or mentally:	Check:
hundreds	tens	ones						

2. Complete all of the *if...then* statements. Draw a number bond to represent the related facts.

a. If  $928 - \underline{\hspace{2cm}} = 519$ , then  $519 + 409 = \underline{\hspace{2cm}}$ .

b. If  $764 - \underline{\hspace{2cm}} = 391$ , then  $\underline{\hspace{2cm}} + 391 = 764$ .

## Lesson 16

**Objective:** Subtract from multiples of 100 and from numbers with zero in the tens place.

### Suggested Lesson Structure

■ Application Problem	(8 minutes)
■ Fluency Practice	(12 minutes)
■ Concept Development	(30 minutes)
■ Student Debrief	(10 minutes)
<b>Total Time</b>	<b>(60 minutes)</b>

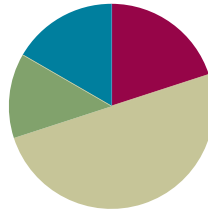

### Application Problem (8 minutes)

Will read 15 more pages than Marcy. Marcy read 38 pages. The book is 82 pages long.

- How many pages did Will read?
- How many more pages does Will need to read to finish the book?

Note: This two-step problem is intended for guided practice as students gain familiarity with the *compare bigger unknown* problem type. Tape diagrams enable students to make sense of the relationships between the numbers and effectively choose an operation to both represent the situation and solve.

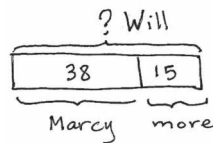

$$38 + 15 = \square$$

Will read 53 pages.

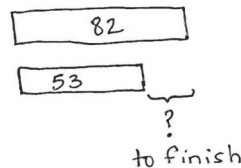

$$82 - 53 = \square$$

$$53 + \square = 82$$

Will needs to read 29 more pages.

### Fluency Practice (12 minutes)

- Sprint: Subtraction from Teens (8 minutes)
- Coin Drop (2 minutes)
- More and Less (2 minutes)

### Sprint: Subtraction from Teens (8 minutes)

Materials: (S) Subtraction from Teens Sprint

Note: Students practice subtraction from teens to gain mastery of the sums and differences within 20.

**Coin Drop (2 minutes)**

Materials: (T) 10 dimes, 10 pennies, can

Note: In this activity, students practice adding and subtracting ones and tens using coins in preparation for Module 7.

T: (Hold up a penny.) Name my coin.

S: A penny.

T: How much is it worth?

S: 1 cent.

T: Listen carefully as I drop coins in my can. Count along in your minds.

Drop in some pennies and ask how much money is in the can. Take out some pennies and show them. Ask how much money is still in the can. Continue adding and subtracting pennies for a minute or so. Then, repeat the activity with dimes and then with dimes and pennies.

**More and Less (2 minutes)**

Materials: (T) 10 dimes, 10 pennies

Note: In this activity, students practice adding and subtracting ones and tens using coins.

T: Let's count by tens. (Move dimes to the side while counting.)

S: 10, 20, 30, 40, 50, 60.

T: How many dimes are shown?

S: 6 dimes.

T: What is the value of 6 dimes?

S: 60 cents.

T: What is 5 cents more? (Move 5 pennies.)

S: 65 cents.

T: Give the number sentence.

S:  $60 \text{ cents} + 5 \text{ cents} = 65 \text{ cents}$ .

T: What is 10 cents less? (Move 1 dime.)

S: 55 cents.

T: Give the number sentence.

S:  $65 \text{ cents} - 10 \text{ cents} = 55 \text{ cents}$ .

Continue to repeat this line of questioning with a similar sequence of numbers.



### Concept Development (30 minutes)

Materials: (S) Personal white board, math journal or paper

Note: This Concept Development extends student learning from Module 4's Lessons 27 and 28.

#### Problem 1: 402 – 231

T: (Write  $402 - 231$  horizontally.) Let's solve this problem using a math drawing and the algorithm.

T: Rewrite the problem with me. (Write the problem vertically as students do the same.)

T: Which number is the whole?

S: 402.

T: Let's make a chip model to show the whole. I'll draw it on the board while you draw yours. Whisper-count as you draw your chips.

S: (Whisper-count and draw.) 100, 200, 300, 400, 401, 402.

T: Let's draw our magnifying glass and get ready to subtract! (Draw a circle around 402 as students do the same.)

T: Look at your chip model. Are we ready to subtract the ones?

S: Yes!

T: Moving on, let's look at the tens place. I don't see any tens in the tens place on the model. Point to the digit that represents this in vertical form.

S: (Point to the 0.)

T: The zero holds the tens place open and tells us the number is 402.

T: Without that 0, what number would we read? (Write 42.)

S: 42.

T: (Erase 42.) Yes, so we must be precise when writing and representing numbers.

T: Where can we get some tens so we can subtract 3 tens?

S: The hundreds place. → Decompose a hundred.  
→ Rename 1 hundred as 10 tens.

T: Let's show that on our chip models. Count with me as we rename 1 hundred as 10 tens. (Cross off 1 hundred, draw an arrow to the tens place, and draw 10 dots, or tens.)

S: (Draw and count.) 10, 20, 30, 40, 50, 60, 70, 80, 90, 100.

T: Show that in vertical form. As I do the same, check your work with mine. (Cross off 4, and write 3 above the hundreds place, and then cross off 0, and write 10 above the tens place. Students do the same.)

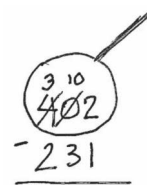
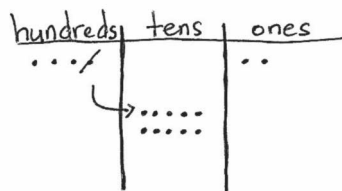

#### NOTES ON MULTIPLE MEANS OF ENGAGEMENT:

It is easy to lose students when subtraction involves zeros in the minuend. Check frequently for understanding by establishing a quiet, non-verbal signal (e.g., thumbs-up) that students can use to indicate whether they are following.

- T: Are we ready to subtract now in the tens place?  
 S: Yes!  
 T: Let's look at the hundreds place. Are we ready to subtract in the hundreds?  
 S: Yes!  
 T: Then, we're ready to subtract! (Allow students time to complete the subtraction.)  
 T: Talk with your partner. Take turns sharing how you showed the subtraction on your chip model and using the algorithm. (Allow students time to share.)  
 T: Read the complete number sentence.  
 S:  $402 - 231 = 171$ .  
 T: How can we prove that our answer is correct?  
 S: Add the parts to see if they equal the whole.  
 T: Yes! Please check your answer by drawing a chip model to add the two parts. If you are correct, write the number bond for this problem.

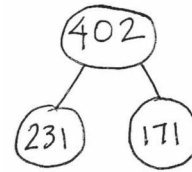

Circulate to check for understanding, and support students who struggle. Project student work, or call students to the board to show the chip model, vertical form, and number bond. Encourage students to use place value language to explain their work.

### Problem 2: 800 – 463

Follow the above procedure to guide students as they write  $800 - 463$  vertically and model it.

- T: Talk with your partner. What do you notice about the whole, and what do we need to do?  
 S: This time, there are no tens and no ones. → We need to unbundle a hundred to make tens *and* ones. → We need to rename 1 hundred as 9 tens 10 ones.  
 T: Let's do that. Count aloud as you rename 1 hundred as 9 tens 10 ones. (Cross off 1 hundred, draw an arrow to the tens place, and draw 9 tens as students do the same.)  
 S: 10, 20, 30, 40, 50, 60, 70, 80, 90.  
 T: Stop! Now, count on as you draw the ones. (Draw 10 ones as students do the same.)  
 S: 91, 92, 93, 94, 95, 96, 97, 98, 99, 100.  
 T: So, 1 hundred is the same as 9 tens 10 ones. True?  
 S: True!

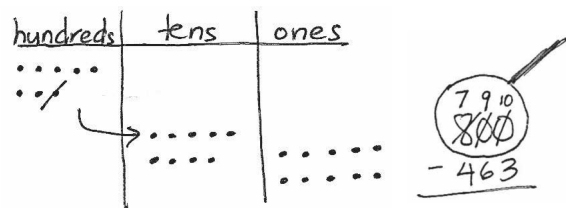

#### NOTES ON MULTIPLE MEANS OF REPRESENTATION:

While some students prefer to rename 800 in one step (e.g. 7 hundreds, 9 tens, 10 ones), others may need the intermediate step of renaming a hundred as 10 tens before renaming a ten as 10 ones. Allow students to use place value disks or chips to model the decomposition in two steps.

Continue using the procedure from Problem 1 to guide students as they complete the subtraction on both the model and in vertical form, share their work, and verify their solution to Problem 2 using addition.

Repeat the process for  $908 - 120$ ,  $705 - 36$ ,  $600 - 316$ , and  $500 - 327$ . Continue to support students who struggle, but as they demonstrate proficiency, instruct them to work on the Problem Set independently.

### Problem Set (10 minutes)

Students should do their personal best to complete the Problem Set within the allotted 10 minutes. For some classes, it may be appropriate to modify the assignment by specifying which problems they work on first. Some problems do not specify a method for solving. Students should solve these problems using the RDW approach used for Application Problems.

### Student Debrief (10 minutes)

**Lesson Objective:** Subtract from multiples of 100 and from numbers with zero in the tens place.

The Student Debrief is intended to invite reflection and active processing of the total lesson experience.

Invite students to review their solutions for the Problem Set. They should check work by comparing answers with a partner before going over answers as a class. Look for misconceptions or misunderstandings that can be addressed in the Student Debrief. Guide students in a conversation to debrief the Problem Set and process the lesson.

Any combination of the questions below may be used to lead the discussion.

- For Problem 1(a),  $304 - 53$ , explain how you solved this problem. How could you have solved it mentally?
- For Problem 1(b),  $406 - 187$ , what did you draw on your place value chart? How did you unbundle 400? Did you do it in one or two steps?
- For Problem 1(c),  $501 - 316$ , explain to your partner how you changed a larger unit to make more ones when there were no tens?
- For Problem 1(d), what are two different ways you can unbundle 700? How can you do it in one step? How could you have solved this problem mentally?
- Think like a detective: When you are subtracting three-digit numbers, when do you choose to unbundle a hundred? When do you choose to solve mentally? What clues in the numbers help you choose a solution strategy?

Name Reese Date \_\_\_\_\_

1. Solve vertically or using mental math. Draw chips on the place value chart and unbundle if needed.

a.  $304 - 53 = 251$

$304 - 50 \rightarrow 254 - 3 \rightarrow 251$

hundreds	tens	ones
••X	•••••	•••••
2	5	1

b.  $406 - 187 = 219$

$406 - 100 \rightarrow 306 - 7 \rightarrow 299$   
 $299 - 80 \rightarrow 219$

hundreds	tens	ones
••fX	•••••	•••••
2	1	9

c.  $501 - 316 = 185$

$\begin{array}{r} 491 \\ -316 \\ \hline 185 \end{array}$	hundreds	tens	ones
•••••	•••••	•••••	•••••
1	8	5	

d.  $700 - 509 = 191$

$\begin{array}{r} 690 \\ -509 \\ \hline 191 \end{array}$	hundreds	tens	ones
•••••	•••••	•••••	•••••

e.  $900 - 626 = 274$

$\begin{array}{r} 890 \\ -626 \\ \hline 274 \end{array}$	hundreds	tens	ones
•••••	•••••	•••••	•••••

2. Emily said that  $400 - 247$  is the same as  $399 - 246$ . Write an explanation using pictures, numbers, or words to prove Emily is correct.

$\begin{array}{r} 400 \\ -247 \\ \hline \end{array}$	$\begin{array}{r} 399 \\ -246 \\ \hline \end{array}$
--	--

When you are subtracting you can either add to or subtract from both numbers with the same amount to make the problem easier.  $400 - 247$  is harder than  $399 - 246$  because you have to unbundle. If you just take 1 from each number to get  $399 - 246$  it is easy to solve and the difference does not change.

**Exit Ticket (3 minutes)**

After the Student Debrief, instruct students to complete the Exit Ticket. A review of their work will help with assessing students' understanding of the concepts that were presented in today's lesson and planning more effectively for future lessons. The questions may be read aloud to the students.

## A

Number Correct: \_\_\_\_\_

## Subtraction from Teens

1.	$11 - 10 =$	
2.	$12 - 10 =$	
3.	$13 - 10 =$	
4.	$19 - 10 =$	
5.	$11 - 1 =$	
6.	$12 - 2 =$	
7.	$13 - 3 =$	
8.	$17 - 7 =$	
9.	$11 - 2 =$	
10.	$11 - 3 =$	
11.	$11 - 4 =$	
12.	$11 - 8 =$	
13.	$18 - 8 =$	
14.	$13 - 4 =$	
15.	$13 - 5 =$	
16.	$13 - 6 =$	
17.	$13 - 8 =$	
18.	$16 - 6 =$	
19.	$12 - 3 =$	
20.	$12 - 4 =$	
21.	$12 - 5 =$	
22.	$12 - 9 =$	

23.	$19 - 9 =$	
24.	$15 - 6 =$	
25.	$15 - 7 =$	
26.	$15 - 9 =$	
27.	$20 - 10 =$	
28.	$14 - 5 =$	
29.	$14 - 6 =$	
30.	$14 - 7 =$	
31.	$14 - 9 =$	
32.	$15 - 5 =$	
33.	$17 - 8 =$	
34.	$17 - 9 =$	
35.	$18 - 8 =$	
36.	$16 - 7 =$	
37.	$16 - 8 =$	
38.	$16 - 9 =$	
39.	$17 - 10 =$	
40.	$12 - 8 =$	
41.	$18 - 9 =$	
42.	$11 - 9 =$	
43.	$15 - 8 =$	
44.	$13 - 7 =$	

**B**

## Subtraction from Teens

Number Correct: \_\_\_\_\_

Improvement: \_\_\_\_\_

1.	$11 - 1 =$	
2.	$12 - 2 =$	
3.	$13 - 3 =$	
4.	$18 - 8 =$	
5.	$11 - 10 =$	
6.	$12 - 10 =$	
7.	$13 - 10 =$	
8.	$18 - 10 =$	
9.	$11 - 2 =$	
10.	$11 - 3 =$	
11.	$11 - 4 =$	
12.	$11 - 7 =$	
13.	$19 - 9 =$	
14.	$12 - 3 =$	
15.	$12 - 4 =$	
16.	$12 - 5 =$	
17.	$12 - 8 =$	
18.	$17 - 7 =$	
19.	$13 - 4 =$	
20.	$13 - 5 =$	
21.	$13 - 6 =$	
22.	$13 - 9 =$	

23.	$16 - 6 =$	
24.	$14 - 5 =$	
25.	$14 - 6 =$	
26.	$14 - 7 =$	
27.	$14 - 9 =$	
28.	$20 - 10 =$	
29.	$15 - 6 =$	
30.	$15 - 7 =$	
31.	$15 - 9 =$	
32.	$14 - 4 =$	
33.	$16 - 7 =$	
34.	$16 - 8 =$	
35.	$16 - 9 =$	
36.	$20 - 10 =$	
37.	$17 - 8 =$	
38.	$17 - 9 =$	
39.	$16 - 10 =$	
40.	$18 - 9 =$	
41.	$12 - 9 =$	
42.	$13 - 7 =$	
43.	$11 - 8 =$	
44.	$15 - 8 =$	

Name \_\_\_\_\_

Date \_\_\_\_\_

1. Solve vertically or using mental math. Draw chips on the place value chart and unbundle, if needed.

a.  $304 - 53 =$  \_\_\_\_\_

hundreds	tens	ones

b.  $406 - 187 =$  \_\_\_\_\_

hundreds	tens	ones

c.  $501 - 316 =$  \_\_\_\_\_

hundreds	tens	ones

d.  $700 - 509 =$  \_\_\_\_\_

hundreds	tens	ones

e.  $900 - 626 =$  \_\_\_\_\_

hundreds	tens	ones

2. Emily said that  $400 - 247$  is the same as  $399 - 246$ . Write an explanation using pictures, numbers, or words to prove Emily is correct.



Name \_\_\_\_\_

Date \_\_\_\_\_

Solve vertically or using mental math. Draw chips on the place value chart and unbundle, if needed.

1.  $604 - 143 =$  \_\_\_\_\_

hundreds	tens	ones

2.  $700 - 568 =$  \_\_\_\_\_

hundreds	tens	ones

Name \_\_\_\_\_

Date \_\_\_\_\_

1. Solve vertically or using mental math. Draw chips on the place value chart and unbundle, if needed.

a.  $206 - 89 =$  \_\_\_\_\_

hundreds	tens	ones

b.  $509 - 371 =$  \_\_\_\_\_

hundreds	tens	ones

c.  $607 - 288 =$  \_\_\_\_\_

hundreds	tens	ones

d.  $800 - 608 = \underline{\hspace{2cm}}$

hundreds	tens	ones

e.  $900 - 572 = \underline{\hspace{2cm}}$

hundreds	tens	ones

2. Andy said that  $599 - 456$  is the same as  $600 - 457$ . Write an explanation using pictures, numbers, or words to prove Andy is correct.

## Lesson 17

**Objective:** Subtract from multiples of 100 and from numbers with zero in the tens place.

### Suggested Lesson Structure

■ Application Problem	(8 minutes)
■ Fluency Practice	(12 minutes)
■ Concept Development	(30 minutes)
■ Student Debrief	(10 minutes)
<b>Total Time</b>	<b>(60 minutes)</b>

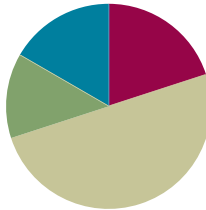

### Application Problem (8 minutes)

Colleen put 27 fewer beads on her necklace than Jenny did. Colleen put on 46 beads. How many beads did Jenny put on her necklace?

If 16 beads fell off of Jenny's necklace, how many beads are still on it?

Note: This *compare bigger unknown* problem is intended for guided practice. It is one of the four most difficult subtypes of word problems in that the word *fewer* suggests subtraction, which would be an incorrect operation.

This type of problem highlights the importance of drawing as a way to understand the relationship between numbers in the problem. The question mark indicates the unknown because students recognize that they are looking for the whole or a missing part.

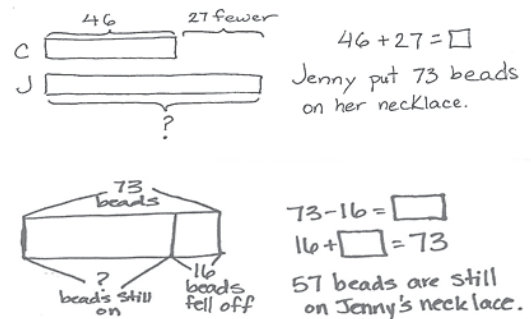

### Fluency Practice (12 minutes)

- Sprint: Subtract Crossing the Ten (8 minutes)
- Using the Nearest Ten to Subtract (2 minutes)
- Subtract Common Units (2 minutes)

### Sprint: Subtract Crossing the Ten (8 minutes)

Materials: (S) Subtract Crossing the Ten Sprint

Note: Students practice subtracting crossing the ten to prepare for the lesson and gain mastery of the sums and differences within 20.

**Using the Nearest Ten to Subtract (2 minutes)**

Note: Reviewing the Grade 1 skill of counting up and down to 10 to subtract gives students a mental strategy to subtract fluently with larger numbers.

T: (Write  $16 - 9$  on the board.) Raise your hand when you know the answer to  $16 - 9$ .

S: 7.

T: (Write in the bond.)  $10 - 9$  is...?

S: 1.

T:  $1 + 6$  is...?

S: 7.

$16 - 9 = \underline{\quad}$	
$\wedge$	
6	10
$10 - 9 = 1$	
$1 + 6 = \underline{\quad}$	

Continue with the following possible sequence:  $13 - 8$ ,  $14 - 9$ ,  $15 - 7$ ,  $16 - 7$ ,  $13 - 9$ ,  $12 - 7$ ,  $22 - 7$ ,  $25 - 7$ ,  $25 - 8$ ,  $26 - 8$ ,  $27 - 8$ ,  $27 - 18$ ,  $37 - 8$ ,  $37 - 18$ ,  $35 - 18$ ,  $45 - 18$ ,  $47 - 19$ , and  $48 - 29$ .

**Subtract Common Units (2 minutes)**

Materials: (S) Personal white board

Note: Reviewing this mental math fluency activity prepares students for understanding the importance of the subtraction algorithm and place value.

T: (Project 55.) Say the number in unit form.

S: 5 tens 5 ones.

T: (Write  $55 - 22 = \underline{\quad}$ .) Say the subtraction sentence, and answer in unit form.

S: 5 tens 5 ones  $-$  2 tens 2 ones  $=$  3 tens 3 ones.

T: Write the subtraction sentence on your personal white board.

Continue with the following possible sequence:  $66 - 33$ ,  $77 - 44$ ,  $177 - 44$ ,  $88 - 33$ , and  $188 - 33$ .

**Concept Development (30 minutes)**

Materials: (S) Personal white board, math journal or paper

Note: This lesson is a continuation of Lesson 16. It extends the student learning from Module 4's Lessons 27 and 28.

**Problem 1: 300  $-$  195**

T: (Write  $300 - 195$  horizontally.) Talk with your partner: What do you notice about these numbers?

S: 195 is close to 200, so it's going to be easy to solve mentally.  $\rightarrow$  If you add 5 to 195, it is 200, which makes it easy to subtract from 300.  $\rightarrow$  Yeah, making a hundred is just like making a ten.

T: Excellent reasoning! It's a good math habit to think about the numbers and how they relate to each other before you decide on a strategy.

- T: Take a moment to solve this problem using the strategy you like best. Be prepared to explain why it works.
- T: Who would like to explain their solution?
- S: I thought about this as an addition problem starting with 195. I used arrow notation and wrote  $195 + 5$  is 200, and  $200 + 100$  is 300, so  $100 + 5$  is 105.  $\rightarrow$  I broke 300 into 100 and 200, and I subtracted 195 from 200. That left 100 and 5, which is 105.  $\rightarrow 305 - 200$  is 105. I added 5 to 195 and 5 to 300. The difference stays the same, 105.
- T: So, we could solve this mentally, use a simplifying strategy, or use vertical form. True?
- S: True!
- T: Keep that in mind, even as we use models and the algorithm to solve some more problems.

### Problem 2: 500 – 213

- T: (Write  $500 - 213$  horizontally.) Let's set this problem up to solve using the chip model and the algorithm.
- T: Rewrite the problem with me. (Write the problem vertically as students do the same.)
- T: Let's make a chip model to show the whole. I'll draw it on the board while you draw yours. Whisper-count as you draw your chips.
- S: (Whisper-count and draw.) 100, 200, 300, 400, 500.
- T: Now, draw the magnifying glass. (Draw a circle around 500 as students do the same.)
- T: Are we ready to subtract?
- S: No.
- T: Tell your partner what we need to do.
- S: There are no tens and no ones, so we have to open up a hundred.  $\rightarrow$  We need to rename 1 hundred as 10 tens. Then, cross out 1 ten and rename it as 10 ones.  $\rightarrow$  We need to change 1 hundred for 9 tens 10 ones.
- T: Let's do that. Count aloud as you rename 1 hundred as 9 tens 10 ones. (Cross off 1 hundred, draw an arrow to the tens place, and draw 9 tens as students do the same.)
- S: (Draw and count.) 10, 20, 30, 40, 50, 60, 70, 80, 90.
- T: Count on as you draw the ones. (Draw 10 ones as students do the same.)
- S: (Draw and count.) 91, 92, 93, 94, 95, 96, 97, 98, 99, 100.
- T: Look at your model. What number is 9 tens?
- S: 90.
- T: And 10 ones?
- S: 10.



#### NOTES ON MULTIPLE MEANS OF ENGAGEMENT:

Although students work extensively with the algorithm in these modules, they will not be assessed on the algorithm until Grade 4. When students build a solid conceptual understanding of subtraction at this level, fluency and accuracy with vertical form should increase greatly.

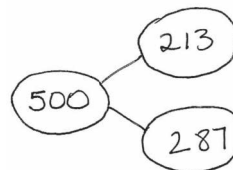
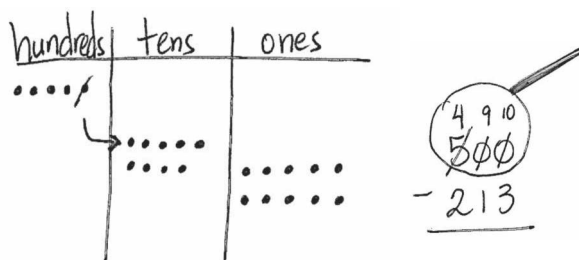

T:  $90 + 10 = \dots?$

S: 100.

T: So, we can rename 1 hundred as 9 tens 10 ones. True?

S: True!

T: Now, we need to show these changes using the algorithm. As I record the changes on the numbers, check your work with mine. (Cross off 5, and write 4 above the hundreds place. Cross off 0 tens, and write 9 above the tens place, then cross off 0 ones, and write 10 above the ones place.)

T: Complete the subtraction, and then take turns sharing how your work on the chip model matches the steps in vertical form. (Allow students time to share.)

T: Read the complete number sentence.

S:  $500 - 213 = 287$ .

T: How can we prove that our answer is correct?

S: Add the parts to see if they equal the whole.

T: Correct! Please check your answer by drawing a chip model to add the two parts. If you are correct, write the number bond for this problem.

Circulate to check for understanding and to support students who struggle. Project student work or call students to the board to show the chip model, vertical form, and number bond. Encourage students to use place value language to explain their work.

### Problem 3: $603 - 487$

Follow the above procedure to guide students as they write  $603 - 487$  vertically, model it, and solve. Remind them to be precise in lining up the digits and drawing their chips in neat 5-groups. Encourage students to use place value language to explain each action that they take on their model and how it is represented using vertical form. Instruct students to check their work with addition and explain why this method works.

Repeat the process for  $801 - 634$  and  $900 - 576$  or move on to the Problem Set. Continue to support struggling students, but as they demonstrate proficiency, instruct them to work on the Problem Set independently.

### Problem Set (10 minutes)

Students should do their personal best to complete the Problem Set within the allotted 10 minutes. For some classes, it may be appropriate to modify the assignment by specifying which problems they work on first. Some problems do not specify a method for solving. Students should solve these problems using the RDW approach used for Application Problems.



#### NOTES ON MULTIPLE MEANS OF EXPRESSION:

For students who may be impatient to use the algorithm alone, encourage them to use the models to show their thinking. Explain that, while the student may know what she is doing, others who look at her work are helped by seeing the work written out. Models are also helpful for checking work.

**Student Debrief (10 minutes)**

**Lesson Objective:** Subtract from multiples of 100 and from numbers with zero in the tens place.

The Student Debrief is intended to invite reflection and active processing of the total lesson experience.

Invite students to review their solutions for the Problem Set. They should check work by comparing answers with a partner before going over answers as a class. Look for misconceptions or misunderstandings that can be addressed in the Student Debrief. Guide students in a conversation to debrief the Problem Set and process the lesson.

Any combination of the questions below may be used to lead the discussion.

- For Problem 1, which problems did you choose to solve mentally? Why? What made some easier than others?
- For Problem 1(b), how did you rename 400 using your chips? Show me what 400 looks like after you have renamed the units.
- Explain to your partner the steps you took to set up Problem 1(c). How was this similar to 1(b)?
- Trey solved Problem 1(d),  $800 - 606$ , by using place value. He started with  $800 - 600 = 200$ . Then, he added 6 more, since one part was 606, so the answer was 206. What was his error?
- For Problem 1(d), explain the meaning of the 9 in the tens place.

**Exit Ticket (3 minutes)**

After the Student Debrief, instruct students to complete the Exit Ticket. A review of their work will help with assessing students' understanding of the concepts that were presented in today's lesson and planning more effectively for future lessons. The questions may be read aloud to the students.

Name Maya Date \_\_\_\_\_

1. Solve vertically or using mental math. Draw chips on the place value chart and unbundle if needed.

a.  $200 - 113 = 87$

$200 \xrightarrow{-100} 100 \xrightarrow{-10} 90 \xrightarrow{-3} 87$

hundreds	tens	ones
2	0	0
1	8	7

b.  $400 - 247 = 153$

hundreds	tens	ones
4	0	0
3	5	3

c.  $700 - 428 = 272$

hundreds	tens	ones
7	0	0
5	7	2

d.  $800 - 606 = 194$

$800 \xrightarrow{-600} 200 \xrightarrow{-6} 194$

hundreds	tens	ones
8	0	0
1	9	4

e.  $901 - 404 = 497$

hundreds	tens	ones
9	0	1
4	9	7

2. Solve  $600 - 367$ . Then, check your work using addition.

Solution: $600 \xrightarrow{-300} 300 \xrightarrow{-60} 240 \xrightarrow{-7} 233$	Check: <table border="1"> <thead> <tr> <th>H</th> <th>T</th> <th>O</th> </tr> </thead> <tbody> <tr> <td>2</td> <td>3</td> <td>3</td> </tr> <tr> <td>3</td> <td>6</td> <td>7</td> </tr> <tr> <td>6</td> <td>0</td> <td>0</td> </tr> </tbody> </table>	H	T	O	2	3	3	3	6	7	6	0	0
H	T	O											
2	3	3											
3	6	7											
6	0	0											



## A

Number Correct: \_\_\_\_\_

## Subtract Crossing the Ten

1.	$10 - 1 =$	
2.	$10 - 2 =$	
3.	$20 - 2 =$	
4.	$40 - 2 =$	
5.	$10 - 2 =$	
6.	$11 - 2 =$	
7.	$21 - 2 =$	
8.	$51 - 2 =$	
9.	$10 - 3 =$	
10.	$11 - 3 =$	
11.	$21 - 3 =$	
12.	$61 - 3 =$	
13.	$10 - 4 =$	
14.	$11 - 4 =$	
15.	$21 - 4 =$	
16.	$71 - 4 =$	
17.	$10 - 5 =$	
18.	$11 - 5 =$	
19.	$21 - 5 =$	
20.	$81 - 5 =$	
21.	$10 - 6 =$	
22.	$11 - 6 =$	

23.	$21 - 6 =$	
24.	$91 - 6 =$	
25.	$10 - 7 =$	
26.	$11 - 7 =$	
27.	$31 - 7 =$	
28.	$10 - 8 =$	
29.	$11 - 8 =$	
30.	$41 - 8 =$	
31.	$10 - 9 =$	
32.	$11 - 9 =$	
33.	$51 - 9 =$	
34.	$12 - 3 =$	
35.	$82 - 3 =$	
36.	$13 - 5 =$	
37.	$73 - 5 =$	
38.	$14 - 6 =$	
39.	$84 - 6 =$	
40.	$15 - 8 =$	
41.	$95 - 8 =$	
42.	$16 - 7 =$	
43.	$46 - 7 =$	
44.	$68 - 9 =$	

**B**

## Subtract Crossing the Ten

Number Correct: \_\_\_\_\_

Improvement: \_\_\_\_\_

1.	$10 - 2 =$	
2.	$20 - 2 =$	
3.	$30 - 2 =$	
4.	$50 - 2 =$	
5.	$10 - 2 =$	
6.	$11 - 2 =$	
7.	$21 - 2 =$	
8.	$61 - 2 =$	
9.	$10 - 3 =$	
10.	$11 - 3 =$	
11.	$21 - 3 =$	
12.	$71 - 3 =$	
13.	$10 - 4 =$	
14.	$11 - 4 =$	
15.	$21 - 4 =$	
16.	$81 - 4 =$	
17.	$10 - 5 =$	
18.	$11 - 5 =$	
19.	$21 - 5 =$	
20.	$91 - 5 =$	
21.	$10 - 6 =$	
22.	$11 - 6 =$	

23.	$21 - 6 =$	
24.	$41 - 6 =$	
25.	$10 - 7 =$	
26.	$11 - 7 =$	
27.	$51 - 7 =$	
28.	$10 - 8 =$	
29.	$11 - 8 =$	
30.	$61 - 8 =$	
31.	$10 - 9 =$	
32.	$11 - 9 =$	
33.	$31 - 9 =$	
34.	$12 - 3 =$	
35.	$92 - 3 =$	
36.	$13 - 5 =$	
37.	$43 - 5 =$	
38.	$14 - 6 =$	
39.	$64 - 6 =$	
40.	$15 - 8 =$	
41.	$85 - 8 =$	
42.	$16 - 7 =$	
43.	$76 - 7 =$	
44.	$58 - 9 =$	

Name \_\_\_\_\_

Date \_\_\_\_\_

1. Solve vertically or using mental math. Draw chips on the place value chart and unbundle, if needed.

a.  $200 - 113 =$  \_\_\_\_\_

hundreds	tens	ones

b.  $400 - 247 =$  \_\_\_\_\_

hundreds	tens	ones

c.  $700 - 428 =$  \_\_\_\_\_

hundreds	tens	ones

d.  $800 - 606 =$  \_\_\_\_\_

hundreds	tens	ones

e.  $901 - 404 =$  \_\_\_\_\_

hundreds	tens	ones

2. Solve  $600 - 367$ . Then, check your work using addition.

Solution:

Check:

Name \_\_\_\_\_

Date \_\_\_\_\_

Solve vertically or using mental math. Draw chips on the place value chart and unbundle, if needed.

1.  $600 - 432 =$  \_\_\_\_\_

hundreds	tens	ones

2.  $303 - 254 =$  \_\_\_\_\_

hundreds	tens	ones

Name \_\_\_\_\_

Date \_\_\_\_\_

1. Solve vertically or using mental math. Draw chips on the place value chart and unbundle, if needed.

a.  $200 - 123 =$  \_\_\_\_\_

hundreds	tens	ones

b.  $400 - 219 =$  \_\_\_\_\_

hundreds	tens	ones

c.  $700 - 542 =$  \_\_\_\_\_

hundreds	tens	ones

d.  $800 - 409 =$  \_\_\_\_\_

hundreds	tens	ones

e.  $905 - 606 =$  \_\_\_\_\_

hundreds	tens	ones

2. Solve  $800 - 567$ . Then, check your work using addition.

Solution:	Check:
-----------	--------

## Lesson 18

**Objective:** Apply and explain alternate methods for subtracting from multiples of 100 and from numbers with zero in the tens place.

### Suggested Lesson Structure

■ Application Problem	(8 minutes)
■ Fluency Practice	(10 minutes)
■ Concept Development	(32 minutes)
■ Student Debrief	(10 minutes)
<b>Total Time</b>	<b>(60 minutes)</b>

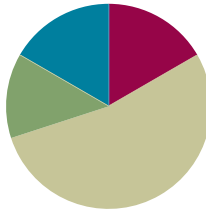

### Application Problem (8 minutes)

Joseph collected 49 golf balls from the course. He still had 38 fewer than his friend Ethan.

- How many golf balls did Ethan have?
- If Ethan gave Joseph 24 golf balls, who had more golf balls? How many more?

a. 

Ethan had 87 golf balls.

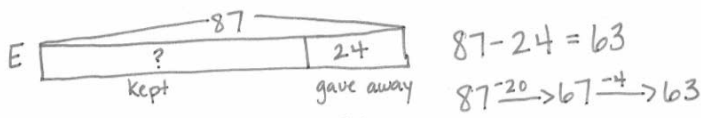
b. 

Ethan had 63 golf balls.

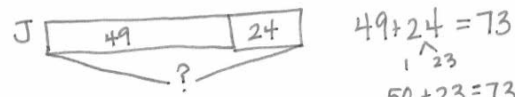

Joseph had 73 golf balls.

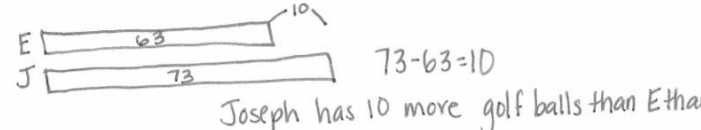

Joseph has 10 more golf balls than Ethan.



#### NOTES ON MULTIPLE MEANS OF ACTION AND EXPRESSION:

Initially adjust numbers in the calculation so that students can see that they need to add rather than subtract, as the word *fewer* suggests.

Try replacing the two-digit numbers with single-digit numbers to emphasize the relationships. For example, Joseph collected six golf balls from the course. He still had three fewer than his friend. With smaller, more manageable numbers, students can use one-to-one matching to make sense of this comparison problem type.

Use concrete materials to model the second part for students who still struggle to grasp the concept.



Note: In addition to the *compare bigger unknown* component of Lesson 17's Application Problem, this problem requires students to shift quantities from one boy to the other (24 from Joseph to Ethan) and then to find the difference. In this case, drawing a tape diagram highlights the shifting quantities and enables students to visualize the more complex processes. Lead students in the RDW process, or encourage them to work together to solve and check their work.

### Fluency Practice (10 minutes)

- Grade 2 Core Fluency Practice Sets (5 minutes)
- Get the Ten Out and Subtract (5 minutes)

### Grade 2 Core Fluency Practice Sets (5 minutes)

Materials: (S) Grade 2 Core Fluency Practice Sets (Lesson 14 Core Fluency Practice Sets)

Note: During Topic C and for the remainder of the year, each day's fluency activity includes an opportunity for review and mastery of the sums and differences with totals through 20 by means of the Core Fluency Practice Sets or Sprints. In Lesson 14, Practice Sets are provided, and the process is explained in detail.

### Get the Ten Out and Subtract (5 minutes)

Note: Students practice taking out the ten and subtracting to prepare for unbundling a ten in today's lesson.

T: For every expression I give, subtract the ones from ten. When I say  $12 - 4$ , you say  $10 - 4 = 6$ .  
Ready?

T:  $12 - 4$ .

S:  $10 - 4 = 6$ .

T:  $13 - 7$ .

S:  $10 - 7 = 3$ .

Practice taking the ten out of expressions fluently before adding the ones back.

T: Now, let's add back the ones.

T:  $12 - 4$ . Take from ten.

S:  $10 - 4 = 6$ .

T: Now, add back the ones.

S:  $6 + 2 = 8$ .

Continue with the following possible sequence:  $13 - 7$ ,  $11 - 8$ ,  $13 - 9$ ,  $15 - 7$ , and  $14 - 8$ .

### Concept Development (32 minutes)

Materials: (S) Personal white board

#### Problem 1: Use compensation to solve $300 - 159$ .

T: (Write  $300 - 159$  on the board.) We know we can use vertical form to subtract from the hundred. Is this something we can do quickly?

S: No, because we have to decompose numbers. → No, we have to unbundle twice to subtract.

T: I'm going to show you a more efficient way to subtract.

T: (Draw the tape diagram to the right on the board.) What happens if I take one off each number? What is my new subtraction problem?

S:  $299 - 158$ .

T: (Draw a new tape diagram showing the compensation.)

T: Is this any easier to solve? Turn and talk with a partner.

S: Yes! There's no renaming. → Now, we're ready to subtract in all place values!

T: Solve this problem, and turn your personal white board over when you are finished.

T: What is  $299 - 158$ ?

S: 141.

T: Is this similar to a strategy you've used before? Talk with a partner.

S: It's like when we added the same number to both numbers. → Yes, like with those other tape diagrams where they both got bigger by the same amount. → I think it was called compensation.

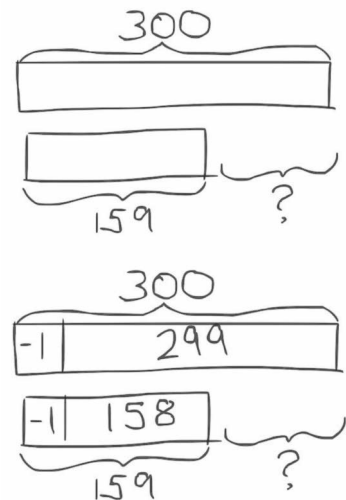

#### Problem 2: Add to solve $400 - 278$ .

T: (Write  $400 - 278$  on the board.) Let's try a different way to subtract from the hundred. Can we use a different operation to solve?

S: Yes, we can start with 278 and count up to 400. → We can start with 278, which is one part, and use the arrow way to show the other part. → 400 minus 278 is like 278 plus something equals 400.

T: (Draw a number bond with these numbers on the board.)

T: (Write  $278 + \underline{\quad} = 400$ .) Why can I write the problem like this? Talk with a partner.

S: Because 400 is the whole, and we know one part. → Part plus part makes whole. We don't know one of the parts, so we make it a blank.

T: Let's use the arrow way to solve this problem. (Write 278 → on the board.) How many more do we need to make the next ten?

S: 2.

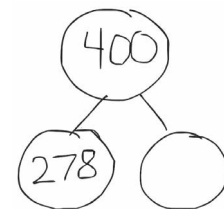

$$278 \xrightarrow{+2} 280 \xrightarrow{+20} 300 \xrightarrow{+100} 400$$

$$400 - 278 = 122$$

- T: (Write 2 above the arrow, then 280.)
- T: How many more do we need now to get to the next hundred? (Record student responses.)
- S: 20. → 2 tens.
- T: How many more do we need to get to our whole?
- S: 100.
- T: We wrote 2, then 20, then 100. Put them altogether, and what do we get?
- S: 122.
- T: So,  $400 - 278$  is ...?
- S: 122.

**Problem 3: 605 – 498**

- T: Now, let's subtract from a number with a zero in the tens place. Which strategies could we use to solve this problem?
- S: We could use the arrow way to solve it with addition because it's easy to make 500 and then get to 605.  
→ We could take 6 off both numbers to make  $599 - 492$ , which means we don't have to do any renaming.  
→ We could just use vertical form.

Take students through the process of solving the problem by relating the chip model to vertical form, renaming 605 as 5 hundreds, 9 tens, 15 ones in one step. When finished, engage students in a discussion about which methods they prefer.

Instruct students to work in pairs through the following problems, discussing which strategy they think would work best for each problem:  $500 - 257$ ,  $702 - 195$ , and  $600 - 314$ . As students demonstrate proficiency renaming in one step, instruct them to work on the Problem Set.

**Problem Set (10 minutes)**

Students should do their personal best to complete the Problem Set within the allotted 10 minutes. For some classes, it may be appropriate to modify the assignment by specifying which problems they work on first. Some problems do not specify a method for solving. Students should solve these problems using the RDW approach used for Application Problems.

**Student Debrief (10 minutes)**

**Lesson Objective:** Apply and explain alternate methods for subtracting from multiples of 100 and from numbers with zero in the tens place.

The Student Debrief is intended to invite reflection and active processing of the total lesson experience.

**NOTES ON  
MULTIPLE MEANS  
OF REPRESENTATION:**

There is no right answer as to which strategy is the best or most efficient for a given problem type. Different students may find certain strategies easier than others. Allow for creativity in modeling, expressing, and critiquing different solution strategies; however, acknowledge that some students may feel most comfortable and capable using a particular method.

Invite students to review their solutions for the Problem Set. They should check work by comparing answers with a partner before going over answers as a class. Look for misconceptions or misunderstandings that can be addressed in the Student Debrief. Guide students in a conversation to debrief the Problem Set and process the lesson.

Any combination of the questions below may be used to lead the discussion.

- For Problem 1, how did you use the arrow way to solve? What did you add on first to efficiently solve each problem? Why?
- For Problem 2, explain the meaning of the 9 in the tens place. Where is the other ten?
- For Problem 3(a),  $600 - 437$ , explain the strategy you chose to solve. Why was using the arrow way easier than subtracting using the algorithm?
- For Problem 3(b),  $808 - 597$ , how did you rename 808 for subtraction? What does that look like using vertical form? Or, why did you choose to solve mentally?
- For Problem 4, how does the smiling student use compensation to make the subtraction problem much simpler? Why is this strategy a good choice here?
- How did you use compensation to solve Problem 5(a) and (b)? What other simplifying strategies could you have used to solve? Which do you prefer?

**Exit Ticket (3 minutes)**

After the Student Debrief, instruct students to complete the Exit Ticket. A review of their work will help with assessing students' understanding of the concepts that were presented in today's lesson and planning more effectively for future lessons. The questions may be read aloud to the students.

Name Ella Date \_\_\_\_\_

1. Use the arrow way and counting on to solve.

a. $300 - 247$ $247 \xrightarrow{+3} 250 \xrightarrow{+50} 300$ $300 - 247 = \boxed{53}$	b. $600 - 465$ $600 \xrightarrow{-400} 200 \xrightarrow{-60} 140 \xrightarrow{-5} 135$ $600 - 465 = \boxed{135}$
--	--

2. Solve vertically and draw a place value chart and chips. Rename in one step.

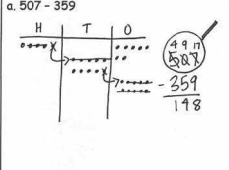
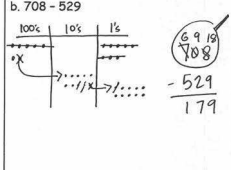
a. $507 - 359$ 	b. $708 - 529$ 
--	---

3. Choose a strategy to solve and explain why you chose that strategy.

a. $600 - 437$ $437 \xrightarrow{+3} 440 \xrightarrow{+60} 500 \xrightarrow{+100} 600$ $437 + 163 = 600$ $600 - 437 = 163$	Explanation: I counted on because it's quicker to count on to get to a hundred than it is to draw chips on a place value chart when subtracting from a hundred. There is a lot of unbundling on the place value chart.
---	---

b.  $808 - 597$   
 $811 - 600 = 211$   
 $597 \xrightarrow{+3} 600$   
 $811 - 600 = 211$   
 $211 - 1 = 210$   
 $210 - 1 = 209$   
 $209 - 1 = 208$   
 $208 - 1 = 207$   
 $207 - 1 = 206$   
 $206 - 1 = 205$   
 $205 - 1 = 204$   
 $204 - 1 = 203$   
 $203 - 1 = 202$   
 $202 - 1 = 201$   
 $201 - 1 = 200$   
 $200 - 1 = 199$   
 $199 - 1 = 198$   
 $198 - 1 = 197$   
 $197 - 1 = 196$   
 $196 - 1 = 195$   
 $195 - 1 = 194$   
 $194 - 1 = 193$   
 $193 - 1 = 192$   
 $192 - 1 = 191$   
 $191 - 1 = 190$   
 $190 - 1 = 189$   
 $189 - 1 = 188$   
 $188 - 1 = 187$   
 $187 - 1 = 186$   
 $186 - 1 = 185$   
 $185 - 1 = 184$   
 $184 - 1 = 183$   
 $183 - 1 = 182$   
 $182 - 1 = 181$   
 $181 - 1 = 180$   
 $180 - 1 = 179$   
 $179 - 1 = 178$   
 $178 - 1 = 177$   
 $177 - 1 = 176$   
 $176 - 1 = 175$   
 $175 - 1 = 174$   
 $174 - 1 = 173$   
 $173 - 1 = 172$   
 $172 - 1 = 171$   
 $171 - 1 = 170$   
 $170 - 1 = 169$   
 $169 - 1 = 168$   
 $168 - 1 = 167$   
 $167 - 1 = 166$   
 $166 - 1 = 165$   
 $165 - 1 = 164$   
 $164 - 1 = 163$   
 $163 - 1 = 162$   
 $162 - 1 = 161$   
 $161 - 1 = 160$   
 $160 - 1 = 159$   
 $159 - 1 = 158$   
 $158 - 1 = 157$   
 $157 - 1 = 156$   
 $156 - 1 = 155$   
 $155 - 1 = 154$   
 $154 - 1 = 153$   
 $153 - 1 = 152$   
 $152 - 1 = 151$   
 $151 - 1 = 150$   
 $150 - 1 = 149$   
 $149 - 1 = 148$   
 $148 - 1 = 147$   
 $147 - 1 = 146$   
 $146 - 1 = 145$   
 $145 - 1 = 144$   
 $144 - 1 = 143$   
 $143 - 1 = 142$   
 $142 - 1 = 141$   
 $141 - 1 = 140$   
 $140 - 1 = 139$   
 $139 - 1 = 138$   
 $138 - 1 = 137$   
 $137 - 1 = 136$   
 $136 - 1 = 135$   
 $135 - 1 = 134$   
 $134 - 1 = 133$   
 $133 - 1 = 132$   
 $132 - 1 = 131$   
 $131 - 1 = 130$   
 $130 - 1 = 129$   
 $129 - 1 = 128$   
 $128 - 1 = 127$   
 $127 - 1 = 126$   
 $126 - 1 = 125$   
 $125 - 1 = 124$   
 $124 - 1 = 123$   
 $123 - 1 = 122$   
 $122 - 1 = 121$   
 $121 - 1 = 120$   
 $120 - 1 = 119$   
 $119 - 1 = 118$   
 $118 - 1 = 117$   
 $117 - 1 = 116$   
 $116 - 1 = 115$   
 $115 - 1 = 114$   
 $114 - 1 = 113$   
 $113 - 1 = 112$   
 $112 - 1 = 111$   
 $111 - 1 = 110$   
 $110 - 1 = 109$   
 $109 - 1 = 108$   
 $108 - 1 = 107$   
 $107 - 1 = 106$   
 $106 - 1 = 105$   
 $105 - 1 = 104$   
 $104 - 1 = 103$   
 $103 - 1 = 102$   
 $102 - 1 = 101$   
 $101 - 1 = 100$   
 $100 - 1 = 99$   
 $99 - 1 = 98$   
 $98 - 1 = 97$   
 $97 - 1 = 96$   
 $96 - 1 = 95$   
 $95 - 1 = 94$   
 $94 - 1 = 93$   
 $93 - 1 = 92$   
 $92 - 1 = 91$   
 $91 - 1 = 90$   
 $90 - 1 = 89$   
 $89 - 1 = 88$   
 $88 - 1 = 87$   
 $87 - 1 = 86$   
 $86 - 1 = 85$   
 $85 - 1 = 84$   
 $84 - 1 = 83$   
 $83 - 1 = 82$   
 $82 - 1 = 81$   
 $81 - 1 = 80$   
 $80 - 1 = 79$   
 $79 - 1 = 78$   
 $78 - 1 = 77$   
 $77 - 1 = 76$   
 $76 - 1 = 75$   
 $75 - 1 = 74$   
 $74 - 1 = 73$   
 $73 - 1 = 72$   
 $72 - 1 = 71$   
 $71 - 1 = 70$   
 $70 - 1 = 69$   
 $69 - 1 = 68$   
 $68 - 1 = 67$   
 $67 - 1 = 66$   
 $66 - 1 = 65$   
 $65 - 1 = 64$   
 $64 - 1 = 63$   
 $63 - 1 = 62$   
 $62 - 1 = 61$   
 $61 - 1 = 60$   
 $60 - 1 = 59$   
 $59 - 1 = 58$   
 $58 - 1 = 57$   
 $57 - 1 = 56$   
 $56 - 1 = 55$   
 $55 - 1 = 54$   
 $54 - 1 = 53$   
 $53 - 1 = 52$   
 $52 - 1 = 51$   
 $51 - 1 = 50$   
 $50 - 1 = 49$   
 $49 - 1 = 48$   
 $48 - 1 = 47$   
 $47 - 1 = 46$   
 $46 - 1 = 45$   
 $45 - 1 = 44$   
 $44 - 1 = 43$   
 $43 - 1 = 42$   
 $42 - 1 = 41$   
 $41 - 1 = 40$   
 $40 - 1 = 39$   
 $39 - 1 = 38$   
 $38 - 1 = 37$   
 $37 - 1 = 36$   
 $36 - 1 = 35$   
 $35 - 1 = 34$   
 $34 - 1 = 33$   
 $33 - 1 = 32$   
 $32 - 1 = 31$   
 $31 - 1 = 30$   
 $30 - 1 = 29$   
 $29 - 1 = 28$   
 $28 - 1 = 27$   
 $27 - 1 = 26$   
 $26 - 1 = 25$   
 $25 - 1 = 24$   
 $24 - 1 = 23$   
 $23 - 1 = 22$   
 $22 - 1 = 21$   
 $21 - 1 = 20$   
 $20 - 1 = 19$   
 $19 - 1 = 18$   
 $18 - 1 = 17$   
 $17 - 1 = 16$   
 $16 - 1 = 15$   
 $15 - 1 = 14$   
 $14 - 1 = 13$   
 $13 - 1 = 12$   
 $12 - 1 = 11$   
 $11 - 1 = 10$   
 $10 - 1 = 9$   
 $9 - 1 = 8$   
 $8 - 1 = 7$   
 $7 - 1 = 6$   
 $6 - 1 = 5$   
 $5 - 1 = 4$   
 $4 - 1 = 3$   
 $3 - 1 = 2$   
 $2 - 1 = 1$   
 $1 - 1 = 0$

4. Prove the student's strategy by solving both problems to check that their solutions are the same. Explain to your partner why this way works.

$799 - 542$ $= 800 - 545$ Now I don't have to change 1 for smaller units.	$799$ $- 542$ <hr/> $257$
---	---------------------------------

5. Use the simplifying strategy from Problem 4 to solve the following two problems.

a. $600 - 547 \rightarrow 599 - 546$ $599$ $- 546$ <hr/> $53$	b. $700 - 513 \rightarrow 699 - 512$ $699$ $- 512$ <hr/> $187$
--	---

Name \_\_\_\_\_

Date \_\_\_\_\_

1. Use the arrow way and counting on to solve.

a. $300 - 247$	b. $600 - 465$
----------------	----------------

2. Solve vertically, and draw a place value chart and chips. Rename in one step.

a. $507 - 359$	b. $708 - 529$
----------------	----------------

3. Choose a strategy to solve, and explain why you chose that strategy.

a. $600 - 437$	Explanation:
----------------	--------------

b. $808 - 597$	Explanation:
----------------	--------------

4. Prove the student's strategy by solving both problems to check that their solutions are the same. Explain to your partner why this way works.



5. Use the simplifying strategy from Problem 4 to solve the following two problems.

a. $600 - 547$	b. $700 - 513$
----------------	----------------

Name \_\_\_\_\_

Date \_\_\_\_\_

Choose a strategy to solve, and explain why you chose that strategy.

1. $400 - 265$	Explanation:
2. $507 - 198$	Explanation:

Name \_\_\_\_\_

Date \_\_\_\_\_

1. Use the arrow way and counting on to solve.

a.  $700 - 462$

b.  $900 - 232$

2. Solve vertically, and draw a place value chart and chips. Rename in one step.

a.  $907 - 467$

b.  $803 - 667$

3. Choose a strategy to solve, and explain why you chose that strategy.

a.  $700 - 390$

Explanation:



b. $919 - 657$	Explanation:
----------------	--------------

4. Explain why  $300 - 186$  is the same as  $299 - 185$ .

Explanation:
--------------

5. Solve  $500 - 278$  using the simplifying strategy from Problem 4.

Solution:
-----------



## Topic D

# Student Explanations for Choice of Solution Methods

- Focus Standards:**
- Add and subtract within 1000, using concrete models or drawings and strategies based on place value, properties of operations, and/or the relationship between addition and subtraction; relate the strategy to a written method. Understand that in adding or subtracting three-digit numbers, one adds or subtracts hundreds and hundreds, tens and tens, ones and ones; and sometimes it is necessary to compose or decompose tens or hundreds.
  - Mentally add 10 or 100 to a given number 100–900, and mentally subtract 10 or 100 from a given number 100–900.
  - Explain why addition and subtraction strategies work, using place value and the properties of operations. (Explanations may be supported by drawings or objects.)

**Instructional Days:** 2

**Coherence -Links from:** G1–M2 Introduction to Place Value Through Addition and Subtraction Within 20  
**-Links to:** G3–M2 Place Value and Problem Solving with Units of Measure

Topic D focuses on the application of the tools and concepts presented in Topics A through C. Students synthesize their understanding of addition and subtraction strategies and then use that understanding to determine which of those strategies to apply to a variety of problems, including number bond problems and problems with the unknown in all positions (e.g.,  $200 + \underline{\quad} = 342$  or  $\underline{\quad} - 53 = 400$ ).

Students then discuss and analyze their chosen methods and determine which method is most efficient for the given problem type. For example, when digits are close to the next ten or hundred (e.g.,  $530 - \underline{\quad} = 390$ ), some students might use related addition and mentally add on tens and hundreds, while others might solve the same problem using arrow notation.

Working with these problems provides a sound foundation for future work with word problems. Listening to peer explanations can make certain strategies more accessible for students who struggle; it also allows for more time and practice to achieve mastery.

**A Teaching Sequence Toward Mastery of Student Explanations for Choice of Solution Methods**

**Objective 1: Choose and explain solution strategies and record with a written addition or subtraction method.**  
(Lessons 19–20)

## Lesson 19

**Objective:** Choose and explain solution strategies and record with a written addition or subtraction method.

### Suggested Lesson Structure

■ Fluency Practice	(12 minutes)
■ Concept Development	(38 minutes)
■ Student Debrief	(10 minutes)
<b>Total Time</b>	<b>(60 minutes)</b>

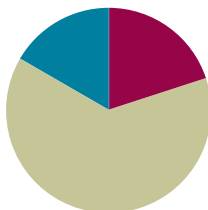

### Fluency Practice (12 minutes)

- Grade 2 Core Fluency Practice Sets (5 minutes)
- Take from the Ten (3 minutes)
- Skip-Counting by Twos (4 minutes)

### Grade 2 Core Fluency Practice Sets (5 minutes)

Materials: (S) Grade 2 Core Fluency Practice Sets (Lesson 14 Core Fluency Practice Sets)

Note: During Topic C and for the remainder of the year, each day's fluency activity includes an opportunity for review and mastery of the sums and differences with totals through 20 by means of the Core Fluency Practice Sets or Sprints. In Lesson 14, Practice Sets are provided, and the process is explained in detail.

### Take from the Ten (3 minutes)

Materials: Personal white board

Note: Students practice taking from the ten to subtract fluently within 20.

T: I say,  $11 - 9$ . You write,  $10 - 9 + 1$ . Wait for my signal. Ready?

T:  $12 - 8$ . Show me your personal white board on my signal.

S:  $10 - 8 + 2$ .

T: Write your answer.

S: 4.

Continue with the following possible sequence:  $13 - 9$ ,  $14 - 8$ ,  $12 - 9$ ,  $11 - 8$ ,  $15 - 9$ ,  $11 - 7$ ,  $16 - 8$ ,  $17 - 9$ , and  $13 - 7$ .

### Skip-Counting by Twos (4 minutes)

Note: Students practice counting by twos in anticipation of learning the foundations of multiplication and division in Module 6.

- T: On my signal, count by ones from 0 to 20 in a whisper. Ready? (Tap the desk while students are counting; knock on the twos. For example, tap, knock, tap, knock, ...)
- T: Did anyone notice what I was doing while you were counting? I was tapping by ones, but I knocked on every other number. Let's count again, and try knocking and tapping with me.
- S: 1 (tap), 2 (knock), 3 (tap), 4 (knock), 5 (tap), 6 (knock), ...
- T: Now, let's count only when we knock. Ready?
- S: (Tap), 2 (knock), (tap), 4 (knock), (tap), 6 (knock), (tap), 8 (knock), ...

Continue this routine up to 20 and back down again.

### Concept Development (38 minutes)

Materials: (S) Personal white board, place value disks (if appropriate for student level)

This lesson gives students the opportunity to choose which strategies to apply to a variety of addition and subtraction problems and to explain their choices and listen to the reasoning of their peers. To allow for this in-depth conversation, the Application Problem has been omitted from Lessons 19 and 20.

The conversations within this lesson can be structured as a whole group, in teams of four, or in partners, depending on what is best for a given class.

#### Problem 1: $180 + 440$

Give students three minutes to solve the problem using the strategy of their choice. Then, invite students to share their work and reasoning.

- T: Turn and talk: Explain your strategy and why you chose it to your small group.
- S1: I used a chip model to represent the hundreds and tens for each number because there were no ones. Then, I added the tens together and the hundreds together. Since there were 12 tens, I renamed 10 tens as 1 hundred, and that leaves 2 tens. 5 hundreds and 1 hundred more makes 6 hundreds. So, my answer is 620.

$$180 \xrightarrow{+400} 580 \xrightarrow{+20} 600 \xrightarrow{+20} 620$$

S2: I used the arrow way. I started with 180, added 400 to get 580, added 20 to make 600, and added 20 more is 620.

S3: I used a number bond to take apart 440. I took 20 from the 440 and added it to 180 to make 200. 200 plus 420 is 620.

T: Turn and talk. How efficient were the strategies we used and why?

S: I think the arrow way was efficient because he did it in his head. → I think the number bond was good because adding onto 200 is easy. → I think the chip model is inefficient because it took a long time to draw all the chips, and with easy numbers, you can do it faster in your head.

$$\begin{array}{r} 180 + 440 \\ \quad \quad \quad \wedge \\ \quad \quad \quad 20 \quad 420 \\ 200 + 420 = 620 \end{array}$$

Consider facilitating a discussion about recognizing a problem that is efficiently solved without the algorithm or math drawings. For example, students should recognize that when adding two numbers with only hundreds and tens, mental math or a simplifying strategy is the best option.

### Problem 2: 400 – 236

Give students three minutes to solve the problem using the strategy of their choice.

T: Turn and talk to your small group. Explain your strategy and why you chose it.

S1: I used a tape diagram to subtract one from each number, so I could subtract without renaming.  $399 - 235$  is 164.

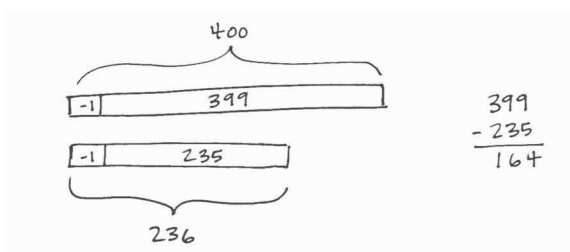

S2: I used the arrow way to count up from 236 to 400. I started at 236 and added 4 to make 240, and then I added 60 more to get to 300. Then, I added 1 hundred to make 400. I added 164 altogether.

$$236 \xrightarrow{+4} 240 \xrightarrow{+60} 300 \xrightarrow{+100} 400$$

$$4 + 60 + 100 = 164$$

S3: I just used the algorithm because I already know that when I have zeros in the tens and ones places, I can rename the whole easily. I changed 400 to 3 hundreds, 9 tens, and 10 ones. Then, I subtracted. I also got 164.

T: Turn and talk. How efficient were the strategies we used and why?

S: I think the arrow way was super-efficient because it was just hop to 240, hop to 300, and hop to 400. → The chip model is slower than other strategies but safe, too, because you can check your work easily with the drawing. → I think vertical form was less efficient for me because without the drawing I ended up getting the answer wrong, and I had to redo it.



#### NOTES ON MULTIPLE MEANS OF ACTION AND EXPRESSION:

Encourage students who repeatedly choose mental math as the most efficient strategy to describe which simplifying strategy they used mentally. Explain that since they need to show their work on assessments, they need to practice writing it down.

**Problem 3: 389 + 411**

- T: (Allow students three minutes to work the problem.) Turn and talk to your small group. Explain your strategy and why you chose it.
- S1: I used a chip model because I saw that I am adding two three-digit numbers. I drew and then added the ones to make a ten. I added the tens to make a hundred, and then I added the hundreds. I recorded my work using new groups below. My answer is 800.

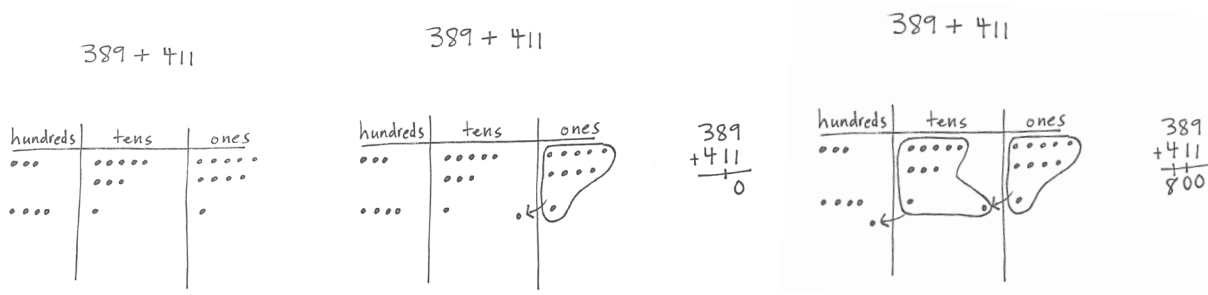

- S2: I chose to use the arrow way because I saw that 389 has 9 in the ones place and 411 has 1 in the ones place, so I knew I would be making a ten. I started at 389 and added 1 to get 390. I added 10 to get 400, and then I added 400 more to get 800. It fit like a puzzle.

$$389 \xrightarrow{+1} 390 \xrightarrow{+10} 400 \xrightarrow{+400} 800$$

- S3: I decided to use a number bond because I noticed that 389 needs 11 to get to 400 and that 411 has 11. So, then I knew a number bond was best. I took 11 from 411 and added it to 389 to get 400, and then I added 400 to get 800.

$$389 + 411$$

/ \

11 400

T: Turn and talk. How efficient were the strategies we used and why?

$$400 + 400 = 800$$

- S: I think the chip model was slow but good for me because then I didn't lose track of making 10 and making 100. → I think the arrow way was great because it is easy to add on the 411 after you take it apart. → I think the number bond was efficient because 11 and 389 makes 400 really easily. Then, you just add on 400 more, and you're done!

If students are ready to move on to the Problem Set, allow them to begin. If they need more discussion, continue the above sequence with the following problems:  $275 + 125$ ,  $672 - 458$ , and  $377 + 350$ .

**Problem Set (10 minutes)**

Students should do their personal best to complete the Problem Set within the allotted 10 minutes. For some classes, it may be appropriate to modify the assignment by specifying which problems they work on first. Some problems do not specify a method for solving. Students should solve these problems using the RDW approach used for Application Problems.

## Student Debrief (10 minutes)

**Lesson Objective:** Choose and explain solution strategies and record with a written addition or subtraction method.

The Student Debrief is intended to invite reflection and active processing of the total lesson experience.

Invite students to review their solutions for the Problem Set. They should check work by comparing answers with a partner before going over answers as a class. Look for misconceptions or misunderstandings that can be addressed in the Student Debrief. Guide students in a conversation to debrief the Problem Set and process the lesson. Any combination of the questions below may be used to lead the discussion.

- Share with a partner: For Problem 1(a) and (b), explain and compare the two strategies used to solve  $500 - 211$ .
- For Problem 1, how could you arrive at the same answer using a different solution strategy? Share and compare with a partner.
- For Problem 2(a), how did you solve? Why? In your opinion, which strategy is most efficient?
- For Problem 2(b), did you use addition or subtraction to solve? Explain your thinking. Can you think of an alternate strategy?
- For Problem 2(c), what were you thinking when you selected a solution strategy to solve? How does knowing your partners to 10 help you to solve quickly?
- For Problem 2(d), what is challenging about solving this problem using vertical form? How could you change this into a simpler problem?

## Exit Ticket (3 minutes)

After the Student Debrief, instruct students to complete the Exit Ticket. A review of their work will help with assessing students' understanding of the concepts that were presented in today's lesson and planning more effectively for future lessons. The questions may be read aloud to the students.

Name Barbara Date \_\_\_\_\_

1. Explain how the two strategies to solve  $500 - 211$  are related.

a.

hundreds	tens	ones
•••••	•••••	•••••
2	8	9

b.

$\begin{array}{r} 4910 \\ 500 \\ -211 \\ \hline 289 \end{array}$
--

The place value chart shows how the hundreds and tens are unbundled with chips. The vertical form shows the same thing but with numbers instead of chips.

2. Solve and explain why you chose that strategy.

<p>a. <math>220 + 390 = 610</math></p> $\begin{array}{r} 210 \\ \uparrow 10 \\ 210 + 400 = 610 \end{array}$	<p>Explanation: I saw that 390 just needs 10 more to make 400, so I used a number bond to take 10 from 220. Then I added very quickly since the problem was easy!</p>
---	---

<p>b. <math>547 - 350 = 197</math></p> $250 \xrightarrow{+50} 300 \xrightarrow{+100} 500$ $500 \xrightarrow{+47} 547$ $100 + 50 + 47 = 197$	<p>Explanation: I counted on using the arrow way because it was quicker than drawing chips and the arrow way (subtracting) was too tricky!</p>
<p>c. <math>464 + 146 = 610</math></p> $464 \xrightarrow{+100} 564 \xrightarrow{+40} 604$ $604 \xrightarrow{+6} 610$	<p>Explanation: I added using the arrow way because I saw that 60 + 40 would make the next hundred and 4 + 6 = 10.</p>
<p>d. <math>600 - 389 = 211</math></p> $\begin{array}{r} 599 \\ -388 \\ \hline 211 \end{array}$	<p>Explanation: I subtracted 1 from each number because I can subtract with the vertical form without chips as long as there's no renaming.</p>



Name \_\_\_\_\_

Date \_\_\_\_\_

1. Explain how the two strategies to solve  $500 - 211$  are related.

<p>a.</p>	<p>b.</p>
-----------	-----------

---



---



---



---



---



---



---



---

2. Solve and explain why you chose that strategy.

a. $220 + 390 = \underline{\hspace{2cm}}$	Explanation: <hr/> <hr/> <hr/> <hr/>
b. $547 - 350 = \underline{\hspace{2cm}}$	Explanation: <hr/> <hr/> <hr/> <hr/>
c. $464 + 146 = \underline{\hspace{2cm}}$	Explanation: <hr/> <hr/> <hr/> <hr/>
d. $600 - 389 = \underline{\hspace{2cm}}$	Explanation: <hr/> <hr/> <hr/> <hr/>

Name \_\_\_\_\_

Date \_\_\_\_\_

Solve and explain why you chose that strategy.

1. $400 + 590 =$ _____	Explanation: _____ _____ _____ _____
2. $775 - 497 =$ _____	Explanation: _____ _____ _____ _____

Name \_\_\_\_\_

Date \_\_\_\_\_

1. Solve and explain why you chose that strategy.

a. $340 + 250 = \underline{\hspace{2cm}}$	Explanation: _____ _____ _____ _____
b. $490 + 350 = \underline{\hspace{2cm}}$	Explanation: _____ _____ _____ _____
c. $519 + 342 = \underline{\hspace{2cm}}$	Explanation: _____ _____ _____ _____

d.  $610 + \underline{\quad\quad\quad} = 784$

Explanation:

---

---

---

---

e.  $700 - 456 = \underline{\quad\quad\quad}$

Explanation:

---

---

---

---

f.  $904 - 395 = \underline{\quad\quad\quad}$

Explanation:

---

---

---

---

## Lesson 20

**Objective:** Choose and explain solution strategies and record with a written addition or subtraction method.

### Suggested Lesson Structure

■ Fluency Practice	(12 minutes)
■ Concept Development	(38 minutes)
■ Student Debrief	(10 minutes)
<b>Total Time</b>	<b>(60 minutes)</b>

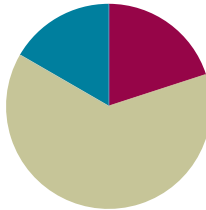

### Fluency Practice (12 minutes)

- Grade 2 Core Fluency Practice Sets (5 minutes)
- Take from the Ten (3 minutes)
- Skip-Counting by Twos (4 minutes)

### Grade 2 Core Fluency Practice Sets (5 minutes)

Materials: (S) Grade 2 Core Fluency Practice Sets (Lesson 14 Core Fluency Practice Sets)

Note: During Topic C and for the remainder of the year, each day's fluency includes an opportunity for review and mastery of the sums and differences with totals through 20 by means of the Core Fluency Practice Sets or Sprints. In Lesson 14, Practice Sets are provided, and the process is explained in detail.

### Take from the Ten (3 minutes)

Materials: Personal white board

Note: Students practice taking from the ten in order to subtract fluently within 20.

T: I say,  $11 - 9$ . You write,  $10 - 9 + 1$ . Wait for my signal. Ready?

T:  $12 - 8$ . Show me your personal white board on my signal.

S:  $10 - 8 + 2$ .

T: Write your answer.

S: 4.

Continue with the following possible sequence:  $14 - 9$ ,  $13 - 8$ ,  $15 - 9$ ,  $11 - 8$ ,  $15 - 8$ ,  $12 - 9$ ,  $16 - 7$ ,  $18 - 9$ , and  $14 - 8$ .

### Skip-Counting by Twos (4 minutes)

Note: Students practice counting by twos in anticipation of learning the foundations of multiplication and division in Module 6.

- T: On my signal, count by ones from 0 to 20 in a whisper. Ready? (Tap the desk while students are counting; knock on the twos. For example, tap, knock, tap, knock, ...)
- T: Did anyone notice what I was doing while you were counting? I was tapping by ones, but I knocked on every other number. Let's count again, and try knocking and tapping with me.
- S: 1 (tap), 2 (knock), 3 (tap), 4 (knock), 5 (tap), 6 (knock), ...
- T: Now, let's count only when we knock. Ready?
- S: (Tap), 2 (knock), (tap), 4 (knock), (tap), 6 (knock), (tap), 8 (knock), ...

Continue this routine up to 20 and back down again.

### Concept Development (38 minutes)

Materials: (S) Personal white board, place value disks (if appropriate for student levels)

This lesson gives students the opportunity to talk about their understanding of addition and subtraction strategies and to choose which strategies to apply to a variety of problems. To allow for this talk, the Application Problem has been omitted from today's lesson.

#### Problem 1: $499 + 166$

Invite students to solve the problem using a strategy of their choice as they did in Lesson 19. Give them three minutes to solve the problem. Then, instruct them to find a partner who used a different strategy to solve. Invite one set of partners up to the board, and lead them through the following conversation:

- T: Partner 1, teach your strategy to Partner 2, and explain why you chose that strategy.
- S1: I used a number bond since 499 is so close to 500. I took 1 from 166 and added it to 499 to get 500; then I added on the rest to get 665.
- T: Partner 2, teach your strategy to your partner, and explain why you chose that strategy.
- S2: I used the arrow way because it's easy to add on from 499. I added 1 hundred. Then, I added 1 more to make 600 and then 65 more. So, I also got 665.
- T: (Point to student drawings on the board.) How were the strategies they used similar? How were they different? Turn and talk with your partner.
- S: They both decomposed 166. → Partner 1 tried to make friendly numbers, like 500. And Partner 2 broke apart 166 and added on parts. → Both partners used a simplifying strategy. → Both partners added 1 to make the next hundred. Partner 1 made 500. Partner 2 made 600.
- T: Did both strategies work?
- S: Yes!

$$\begin{array}{r} 499 + 166 \\ \phantom{499} + 1 \\ \hline 500 + 165 = 665 \end{array}$$

$$499 \xrightarrow{+100} 599 \xrightarrow{+1} 600 \xrightarrow{+65} 665$$

Instruct partners to engage in a conversation similar to the one modeled on the previous page. After partners finish sharing strategies and rationale, give each student a few minutes to solve the problem using her partner's strategy. Circulate and provide support while students check each other's work before returning to their seats for the next problem.

- T: I noticed that very few of you solved using chips or vertical form. Would that strategy also be efficient?
- S: Well, you would have to rename twice. → You should always try to solve mentally if you are close to a hundred. → I can picture the number bond in my head now, and it's easy to add on once you make 500.
- T: I hear some thoughtful responses! Let's take a look at another problem.

### Problem 2: 546 – 297

Give students three minutes to solve using a strategy of their choice. Then, instruct them to find a partner who used a different solution strategy. Prompt them to engage in a conversation similar to the one modeled in Problem 1.

- T: Class, after you solve and find a partner who used a different strategy, I'd like you to share and explain your strategies. (Circulate and listen.)
- S1: I used compensation and added 3 to both numbers so that I could subtract 300 instead of 297. So, 549 minus 300 equals 249. Easy!
- S2: I used vertical form to solve. Because I know the steps, it doesn't take me long. After drawing my magnifying glass, I decomposed twice because there weren't enough tens or ones to subtract. I renamed 546 as 4 hundreds, 13 tens, 16 ones. Then, I subtracted hundreds, tens, and ones, and I got 249.
- T: Turn and talk to your partner: How efficient were the strategies you used and why?
- S: I like the algorithm because it has steps, and it works every time. → Making friendly numbers is a good strategy because you can very easily take away 300 from 549 in your head.
- T: How were the strategies you discussed similar, and how were they different? Turn and talk to your partner.
- S: We both used subtraction to solve. → I used a drawing, and my partner just used vertical form. → I used renaming, but my partner used compensation to make a hundred.



#### NOTES ON MULTIPLE MEANS OF ACTION AND EXPRESSION:

For more introverted students or those who find spoken communication in groups challenging, allow them to write their explanations or to discuss their solutions with a trusted friend.

$$546 - 297 = 249$$

$$549 - 300 = 249$$

$$\begin{array}{r} 546 \\ - 297 \\ \hline \end{array}$$

$$\begin{array}{r} 4 \ 13 \ 16 \\ - 2 \ 9 \ 7 \\ \hline \end{array}$$

$$\begin{array}{r} 4 \ 13 \ 16 \\ - 2 \ 9 \ 7 \\ \hline 2 \ 4 \ 9 \end{array}$$



#### NOTES ON MULTIPLE MEANS OF REPRESENTATION:

Post a list of these strategies and examples on the board so students who are still learning the strategies can refer to it.

After partners finish sharing strategies and rationale, each student takes a few minutes to solve the problem using his partner's strategy. While the teacher circulates and provides support, students check each other's work before returning to their seats for the next problem.



**Problem 3:  $320 + \underline{\hspace{2cm}} = 418$** 

Give students three minutes to solve before finding a partner who used a different solution strategy. Prompt partners to engage in a conversation by following these steps:

1. Share and explain your strategy to your partner.
2. Listen to your partner's strategy.
3. Practice solving using your partner's strategy.
4. Decide if your strategies are efficient.
5. Discuss how your strategies are similar and how they are different.
6. Compliment your partner about his work. Be specific!

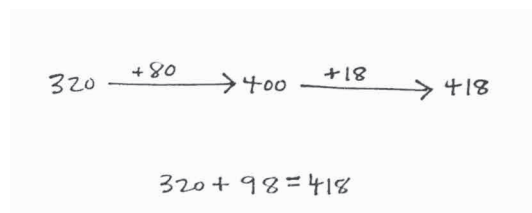
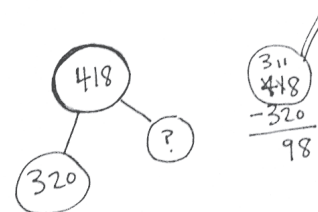

The following reflects possible student explanations:

- I drew a number bond to show the missing part, and then I used related subtraction to solve. I thought drawing a number bond was a good idea because it helped me know where to start to find the answer.
- I used the arrow way to count on to 418. I knew by looking at the problem that I had to add on to 320 to get to 418. I started by adding 80 to get to 400. Then, I added a ten and 8 ones. Altogether, I added 98. So, 320 plus 98 equals 418.

The following reflects possible student discussion:

- I think using the number bond was a good idea because it helps me to see the parts and the whole. → Another idea would be to draw the number bond and then count on to solve. → If you used the arrow way, you could add on 100 and then just take back 2.
- I solved using addition, but you solved with subtraction. → We both knew that 320 was one part, and we were trying to find the missing part. → I counted up to get to 418. You started with 418 and subtracted one part.

The sample responses demonstrate the flexibility students are developing in their application of strategies to solve varied problems. Encourage students to consider the strategies they used and how they could adapt them to best meet their own needs.

If students need more practice, continue with one or more problems from the following suggested sequence:  $334 + 143$ ,  $538 + 180$ ,  $450 + \underline{\hspace{2cm}} = 688$ , and  $746 - \underline{\hspace{2cm}} = 510$ . Otherwise, allow them to begin the Problem Set.

**Problem Set (10 minutes)**

Students should do their personal best to complete the Problem Set within the allotted 10 minutes. For some classes, it may be appropriate to modify the assignment by specifying which problems they work on first. Some problems do not specify a method for solving. Students should solve these problems using the RDW approach used for Application Problems.

## Student Debrief (10 minutes)

**Lesson Objective:** Choose and explain solution strategies and record with a written addition or subtraction method.

The Student Debrief is intended to invite reflection and active processing of the total lesson experience.

Invite students to review their solutions for the Problem Set. They should check work by comparing answers with a partner before going over answers as a class. Look for misconceptions or misunderstandings that can be addressed in the Student Debrief. Guide students in a conversation to debrief the Problem Set and process the lesson.

Any combination of the questions below may be used to lead the discussion.

- For Problem 1, which mental or simplifying strategy did you choose? Why? How was this different from your partner's strategy?
- For Problem 2, did you choose a mental strategy or the algorithm to solve? Why?
- Look at Problem 3. Compare your strategy to your partner's. Which one was more efficient? Defend your reasoning.
- Turn and talk. For Problem 4, did you solve using addition or subtraction? Why? Explain your reasoning using pictures, numbers, or words.
- What are all the possible ways to solve Problem 5? Which one do you prefer?
- Which solution strategies are fastest and easiest for you? Why?

## Exit Ticket (3 minutes)

After the Student Debrief, instruct students to complete the Exit Ticket. A review of their work will help with assessing students' understanding of the concepts that were presented in today's lesson and planning more effectively for future lessons. The questions may be read aloud to the students.

Name Sloane Date \_\_\_\_\_

Step 1: Show your strategy to solve.  
Step 2: Find a classmate who used a different strategy, and copy his work into the box.  
Step 3: Discuss which strategy is more efficient.

1.  $399 + 237 = 636$

a. My strategy	b. Beck's strategy
$\begin{array}{r} 399 + 237 \\ \phantom{3}^{\wedge} 236 \\ 400 + 236 \\ \phantom{2}^{\wedge} 36 \\ 600 + 36 = 636 \end{array}$	

2.  $400 - 298 = 102$

a. My strategy	b. Grace's strategy
$400 \xrightarrow{-200} 200 \xrightarrow{-100} 100 \xrightarrow{-98} 102$	$298 \xrightarrow{+2} 300 \xrightarrow{+100} 400$

3.  $548 + 181 = 729$

a. My strategy	b. Jake's strategy
	$548 \xrightarrow{+100} 648 \xrightarrow{+60} 708 \xrightarrow{+20} 728$ $728 \xrightarrow{+1} 729$

4.  $360 + 394 = 754$

a. My strategy	b. Mary's strategy
$360 \xrightarrow{+40} 400 \xrightarrow{+300} 700 \xrightarrow{+54} 754$ $40 + 300 + 54 = 394$	

5.  $862 - 172 = 690$

a. My strategy	b. Gloria's strategy
	$690 \xrightarrow{+10} 700 \xrightarrow{+100} 800 \xrightarrow{+62} 862$ $10 + 100 + 62 = 172$

Name \_\_\_\_\_

Date \_\_\_\_\_

Step 1: Show your strategy to solve.

Step 2: Find a classmate who used a different strategy, and copy his work into the box.

Step 3: Discuss which strategy is more efficient.

1.  $399 + 237 =$  \_\_\_\_\_

a. My strategy	b. _____'s strategy
----------------	---------------------

2.  $400 - 298 =$  \_\_\_\_\_

a. My strategy	b. _____'s strategy
----------------	---------------------

3.  $548 + 181 = \underline{\hspace{2cm}}$

a. My strategy

b. \_\_\_\_\_'s strategy

4.  $360 + \underline{\hspace{2cm}} = 754$

a. My strategy

b. \_\_\_\_\_'s strategy

5.  $862 - \underline{\hspace{2cm}} = 690$

a. My strategy

b. \_\_\_\_\_'s strategy

Name \_\_\_\_\_

Date \_\_\_\_\_

Solve each problem using two different strategies.

1.  $299 + 156 = \underline{\hspace{2cm}}$

a. First Strategy	b. Second Strategy
-------------------	--------------------

2.  $547 + \underline{\hspace{2cm}} = 841$

a. First Strategy	b. Second Strategy
-------------------	--------------------

Name \_\_\_\_\_

Date \_\_\_\_\_

Solve each problem using two different strategies.

1.  $456 + 244 = \underline{\hspace{2cm}}$

a. First Strategy

b. Second Strategy

2.  $698 + \underline{\hspace{2cm}} = 945$

a. First Strategy

b. Second Strategy

Circle a strategy to solve, and explain why you chose that strategy.

3.  $257 + 160 =$  \_\_\_\_\_

a. *Arrow way or vertical form*

b. Solve:	c. Explanation: _____ _____ _____ _____ _____
-----------	--

4.  $754 - 597 =$  \_\_\_\_\_

a. *Number bond or arrow way*

b. Solve:	c. Explanation: _____ _____ _____ _____ _____
-----------	--

Name \_\_\_\_\_

Date \_\_\_\_\_

1. Solve each problem with a written strategy such as a tape diagram, a number bond, the arrow way, the vertical form, or chips on a place value chart.

<p>a.</p> $460 + 200 = \underline{\hspace{2cm}}$	<p>b.</p> $\underline{\hspace{2cm}} = 865 - 300$	<p>c.</p> $\underline{\hspace{2cm}} + 400 = 598$
<p>d.</p> $240 - 190 = \underline{\hspace{2cm}}$	<p>e.</p> $\underline{\hspace{2cm}} = 760 - 280$	<p>f.</p> $330 - 170 = \underline{\hspace{2cm}}$

2. Use the arrow way to fill in the blanks and solve. Use place value drawings if that will help you.

<p>a.</p> $\begin{array}{ccc} -400 & & +10 \\ 630 \rightarrow & \underline{\hspace{1cm}} & \rightarrow \underline{\hspace{1cm}} \end{array}$ $630 - \underline{\hspace{2cm}} = \underline{\hspace{2cm}}$	<p>b.</p> $\begin{array}{ccc} -\underline{\hspace{1cm}} & & +\underline{\hspace{1cm}} \\ 570 \rightarrow & 270 & \rightarrow 290 \end{array}$ $570 - \underline{\hspace{2cm}} = 290$	<p>c.</p> $\begin{array}{ccc} -400 & & -40 \\ \underline{\hspace{1cm}} \rightarrow & \underline{\hspace{1cm}} & \rightarrow 518 \end{array}$ $\underline{\hspace{2cm}} - 440 = 518$
--	--	---



3. Solve.

Draw a place value chart with chips to model the problems. Show a written subtraction method to check your work.

a.  $756 + 136 = \underline{\hspace{2cm}}$

Subtraction number sentence:

b.  $267 + 545 = \underline{\hspace{2cm}}$

Subtraction number sentence:

Draw a place value chart with chips to model the problems. Show a written addition method to check your work.

c.  $617 - 229 = \underline{\hspace{2cm}}$

Check:

$$d. 700 - 463 = \underline{\hspace{2cm}}$$

Check:

4. Find the missing numbers to make each statement true. Show your strategy to solve.

$$a. 300 - 106 = \underline{\hspace{2cm}}$$

$$b. \underline{\hspace{2cm}} = 407 - 159$$

$$c. 410 - 190 = 420 - \underline{\hspace{2cm}}$$

$$d. 750 - 180 = \underline{\hspace{2cm}} - 200$$

$$e. 900 - \underline{\hspace{2cm}} = 600 - 426$$

5. Martha answered the problem  $456 - 378$  incorrectly. She does not understand her mistake.
- a. Explain to Martha what she did wrong using place value language.

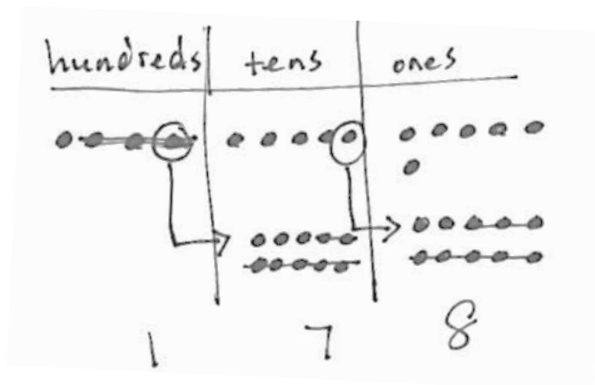

Explanation:

---

---

---

- b. Model an alternative strategy for  $456 - 378$  to help Martha avoid making this mistake again.

**End-of-Module Assessment Task  
Standards Addressed**

Topics A–D

**Use place value understanding and properties of operations to add and subtract.**

- Add and subtract within 1000, using concrete models or drawings and strategies based on place value, properties of operations, and/or the relationship between addition and subtraction; relate the strategy to a written method. Understand that in adding or subtracting three-digit numbers, one adds or subtracts hundreds and hundreds, tens and tens, ones and ones; and sometimes it is necessary to compose or decompose tens or hundreds.
- Mentally add 10 or 100 to a given number 100–900, and mentally subtract 10 or 100 from a given number 100–900.
- Explain why addition and subtraction strategies work, using place value and the properties of operations. (Explanations may be supported by drawings or objects.)

**Evaluating Student Learning Outcomes**

A Progression Toward Mastery is provided to describe steps that illuminate the gradually increasing understandings that students develop *on their way to proficiency*. In this chart, this progress is presented from left (Step 1) to right (Step 4). The learning goal for students is to achieve Step 4 mastery. These steps are meant to help teachers and students identify and celebrate what the students CAN do now and what they need to work on next.

A Progression Toward Mastery				
Assessment Task Item	STEP 1 Little evidence of reasoning without a correct answer.  (1 Point)	STEP 2 Evidence of some reasoning without a correct answer.  (2 Points)	STEP 3 Evidence of some reasoning with a correct answer or evidence of solid reasoning with an incorrect answer.  (3 Points)	STEP 4 Evidence of solid reasoning with a correct answer.  (4 Points)
<b>1</b>	The student solves one or two out of six parts correctly.	The student solves three or four out of six parts correctly.	The student solves five out of six parts correctly.	The student correctly shows a strategy to solve <ul style="list-style-type: none"> <li>a. 660</li> <li>b. 565</li> <li>c. 198</li> <li>d. 50</li> <li>e. 480</li> <li>f. 160</li> </ul>
<b>2</b>	The student solves zero out of three parts correctly.	The student solves one out of three parts correctly.	The student solves two out of three parts correctly.	The student correctly models the arrow way and solves to find <ul style="list-style-type: none"> <li>a. 230, 240, 390, 240</li> <li>b. -300, +20, 280</li> <li>c. 958, 558, 958</li> </ul>
<b>3</b>	The student solves one out of four parts correctly.	The student solves two out of four parts correctly.	The student solves three out of four parts correctly.	The student correctly uses place value chips and writes a related subtraction method to solve <ul style="list-style-type: none"> <li>a. 892</li> <li>b. 812</li> </ul> The student correctly uses place value chips and writes a related addition method to solve <ul style="list-style-type: none"> <li>c. 388</li> <li>d. 237</li> </ul>



A Progression Toward Mastery				
<b>4</b>	The student answers one out of five parts correctly.	The student answers two or three out of five parts correctly.	The student answers four out of five parts correctly.	The student correctly shows a strategy to solve (strategies may vary) <ul style="list-style-type: none"> <li>a. 194</li> <li>b. 248</li> <li>c. 200</li> <li>d. 770</li> <li>e. 726</li> </ul>
<b>5</b>	The student answers zero out of two parts correctly.	The student answers one out of two parts correctly.	The student gives a partial explanation of Martha's error and correctly models an alternative strategy to solve. OR The student gives an explanation of Martha's error and a partial model of an alternative strategy.	The student correctly <ul style="list-style-type: none"> <li>a. Explains that Martha made an error in the hundreds place while subtracting.</li> <li>b. Models an alternative strategy to solve.</li> </ul>

Name Kathy

Date \_\_\_\_\_

1. Solve each problem with a written strategy such as a tape diagram, a number bond, the arrow way, the vertical form, or chips on a place value chart.

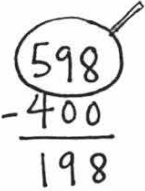
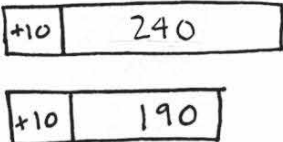
<p>a.</p> $460 + 200 = \underline{660}$ $460 \xrightarrow{+200} 660$	<p>b.</p> $\underline{565} = 865 - 300$ $865 \xrightarrow{-300} 565$	<p>c.</p> $\underline{198} + 400 = 598$ 
<p>d.</p> $240 - 190 = \underline{50}$  $250 - 200 = 50$	<p>e.</p> $\underline{480} = 760 - 280$ $760 \xrightarrow{-300} 460 \xrightarrow{+20} 480$	<p>f.</p> $330 - 170 = \underline{160}$ $330 \xrightarrow{-200} 130 \xrightarrow{+30} 160$

2. Use the arrow way to fill in the blanks and solve. Use place value drawings if that will help you.

<p>a.</p> $630 \xrightarrow{-400} \underline{230} \xrightarrow{+10} \underline{240}$ $630 - \underline{390} = \underline{240}$	<p>b.</p> $570 \xrightarrow{-300} 270 \xrightarrow{+20} 290$ $570 - \underline{280} = 290$	<p>c.</p> $\underline{958} \xrightarrow{-400} \underline{558} \xrightarrow{-40} 518$ $\underline{958} - 440 = 518$
--	--	--

3. Solve.

Draw a place value chart with chips to model the problems. Show a written subtraction method to check your work.

a.  $756 + 136 = \underline{892}$

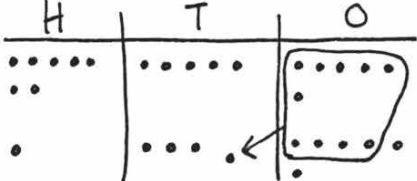

$$\begin{array}{r} 756 \\ + 136 \\ \hline 892 \end{array}$$

Subtraction number sentence:

$$892 - 136 = 756 \quad 892 \xrightarrow{-100} 792 \xrightarrow{-30} 762 \xrightarrow{-6} 756$$

---

b.  $267 + 545 = \underline{812}$

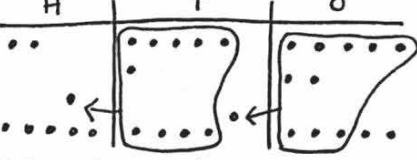

$$\begin{array}{r} 267 \\ + 545 \\ \hline 812 \end{array}$$

Subtraction number sentence:

$$812 - 267 = 545 \quad 812 \xrightarrow{-200} 612 \xrightarrow{-7} 605 \xrightarrow{-60} 545$$

Draw a place value chart with chips to model the problems. Show a written addition method to check your work.

c.  $617 - 229 = \underline{388}$

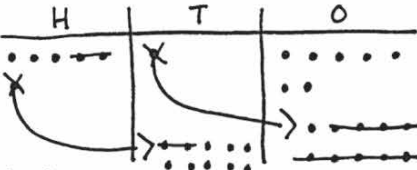

$$\begin{array}{r} 5 \text{ } 10 \text{ } 17 \\ 617 \\ - 229 \\ \hline 388 \end{array}$$

Check:

$$388 + 229 = 617 \quad 388 \xrightarrow{+200} 588 \xrightarrow{+20} 608 \xrightarrow{+9} 617$$



d.  $700 - 463 = 237$

H	T	O
●●●● /X	●●●● /●●●●	●●●● /●●●●

6910 <del>700</del>
-463
237

Check:

$237 + 463 = 700$        $237 \xrightarrow{+400} 637 \xrightarrow{+60} 697 \xrightarrow{+3} 700$

4. Find the missing numbers to make each statement true. Show your strategy to solve.

a.  $300 - 106 = 194$

x1	299
x1	105

299
- 105
194

b.  $248 = 407 - 159$

H	T	O
●●/X	●●●● /●●●●	●●●● /●●●●

3917 <del>407</del>
-159
248

c.  $410 - 190 = 420 - 200$

+10	410
-----	-----

$420 - 200$

d.  $750 - 180 = 770 - 200$

x10	190
-----	-----

+20	750
-----	-----

$770 - 200$

e.  $900 - 726 = 600 - 426$

+300	600
------	-----

$900 - 726$

+300	426
------	-----

$726$

5. Martha answered the problem  $456 - 378$  incorrectly. She does not understand her mistake.
- a. Explain to Martha what she did wrong using place value language.

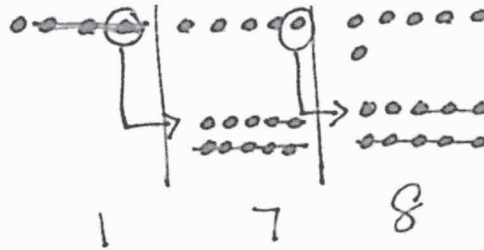

Explanation:

Martha forgot that she unbundled a hundred and took 3 hundreds from 4 hundreds. She should have taken 3 hundreds from 3 hundreds.

- b. Model an alternative strategy for  $456 - 378$  to help Martha avoid making this mistake again.

$$378 + \underline{78} = 456$$

$$378 \xrightarrow{+2} 380 \xrightarrow{+20} 400 \xrightarrow{+56} 456$$

## Answer Key

# Eureka Math Grade 2 Module 5

Special thanks go to the Gordon A. Cain Center and to the Department of Mathematics at Louisiana State University for their support in the development of *Eureka Math*.

For a free *Eureka Math* Teacher  
Resource Pack, Parent Tip  
Sheets, and more please  
visit [www.Eureka.tools](http://www.Eureka.tools)

**Published by Great Minds®.**

Copyright © 2018 Great Minds®. No part of this work may be reproduced, sold, or commercialized, in whole or in part, without written permission from Great Minds®. Noncommercial use is licensed pursuant to a Creative Commons Attribution-NonCommercial-ShareAlike 4.0 license; for more information, go to <http://greatminds.org/copyright>. *Great Minds* and *Eureka Math* are registered trademarks of Great Minds®.

Printed in the U.S.A.

This book may be purchased from the publisher at [eureka-math.org](http://eureka-math.org).

10 9 8 7 6 5 4 3 2 1

ISBN 978-1-64054-321-8



Answer Key

**GRADE 2 • MODULE 5**

Addition and Subtraction Within 1,000 with Word Problems to 100

**This page intentionally left blank**

**Homework**

1.
  - a. 232
  - b. 322
  - c. 212
  - d. 122
  - e. 505
  - f. 399
  - g. 245
  - h. 407
  - i. 100 less
  - j. 10 more
  - k. 319
  - l. 10 less
2.
  - a. 300, 310, 320
  - b. 500, 490, 480
  - c. 443, 343, 243
  - d. 701, 711, 721
  - e. 417, 407, 397
  - f. 818, 808, 798
3.
  - a. 245; 345
  - b. 291; 281
  - c. 407; 10; 397
  - d. 301; 291; 391; 491; 501
4.
  - a. Arrow way shown; 480
  - b. Arrow way shown; 110
  - c. Arrow way shown; 140

## Lesson 2

### Problem Set

1.
  - a. 5, 4; 540
  - b. 640; 640; 640
  - c. 774; 774; 936
  - d. 300; 400; 600
  - e. 300; 483; 126
2.
  - a. 2, 0, 2; 202
  - b. 440; 350; 400
  - c. 262; 167; 331
  - d. 300; 400; 700
  - e. 862; 953; 500
3.
  - a. 589
  - b. 268
  - c. 467
  - d. 700
4. Arrow way shown; 226

### Exit Ticket

1. 260; 280; 400
2. 200; 856; 600

### Homework

1.
  - a. 6, 5; 650
  - b. 520; 730; 640
  - c. 768; 886; 939
  - d. 400; 600; 500
2.
  - a. 2, 0, 8; 208
  - b. 230; 250; 500
  - c. 428; 218; 436
  - d. 400; 600; 800
3.
  - a. 515
  - b. 368
  - c. 480
  - d. 500
  - e. Less
  - f. More



## Lesson 3

### Sprint

#### Side A

1. 43	12. 56	23. 89	34. 88
2. 48	13. 56	24. 89	35. 79
3. 49	14. 60	25. 50	36. 99
4. 50	15. 61	26. 54	37. 89
5. 51	16. 62	27. 55	38. 88
6. 52	17. 67	28. 59	39. 99
7. 55	18. 77	29. 86	40. 79
8. 56	19. 87	30. 80	41. 88
9. 57	20. 88	31. 86	42. 88
10. 56	21. 89	32. 87	43. 78
11. 55	22. 87	33. 88	44. 86

#### Side B

1. 53	12. 66	23. 99	34. 98
2. 58	13. 56	24. 99	35. 89
3. 59	14. 70	25. 60	36. 99
4. 60	15. 71	26. 64	37. 89
5. 61	16. 72	27. 65	38. 88
6. 62	17. 77	28. 69	39. 99
7. 65	18. 87	29. 96	40. 97
8. 66	19. 97	30. 90	41. 88
9. 67	20. 98	31. 96	42. 88
10. 66	21. 99	32. 97	43. 87
11. 65	22. 97	33. 98	44. 77

**Problem Set**

1.
  - a. Arrow way shown; 580; 600; 610
  - b. Arrow way shown; 870; 900; 920
  - c. Arrow way shown; 850; 900; 930
  - d. Arrow way shown; 730; 800; 820
2.
  - a. 690; 700; 710
  - b. 930; 940; 960
  - c. 500; 520; 540
  - d. 310; 650; 830
  - e. 720; 840; 640
3.
  - a. 86
  - b. 90
  - c. 93
  - d. 95
  - e. 860

**Exit Ticket**

1. Arrow way shown; 740; 800; 820
2. Arrow way shown; 900; 920; 910

**Homework**

1.
  - a. Arrow way shown; 460; 500; 510
  - b. Arrow way shown; 720; 800; 810
  - c. Arrow way shown; 750; 800; 820
  - d. Arrow way shown; 630; 700; 720
2.
  - a. 520; 600; 610
  - b. 630; 690; 710
  - c. 600; 620; 610
  - d. 510; 550; 530
  - e. 720; 820; 920
3.
  - a. 54
  - b. 60
  - c. 61
  - d. 62
  - e. 620

## Lesson 4

### Sprint

#### Side A

1. 11	12. 34	23. 67	34. 63
2. 11	13. 34	24. 54	35. 53
3. 11	14. 43	25. 47	36. 82
4. 11	15. 42	26. 56	37. 52
5. 22	16. 34	27. 55	38. 62
6. 22	17. 43	28. 46	39. 51
7. 22	18. 42	29. 75	40. 31
8. 66	19. 24	30. 65	41. 41
9. 44	20. 22	31. 45	42. 54
10. 32	21. 22	32. 45	43. 35
11. 23	22. 22	33. 63	44. 25

#### Side B

1. 22	12. 43	23. 57	34. 53
2. 33	13. 43	24. 47	35. 43
3. 44	14. 34	25. 37	36. 72
4. 77	15. 32	26. 76	37. 62
5. 11	16. 43	27. 66	38. 52
6. 22	17. 34	28. 56	39. 61
7. 33	18. 32	29. 85	40. 41
8. 77	19. 23	30. 75	41. 31
9. 55	20. 12	31. 65	42. 54
10. 23	21. 21	32. 55	43. 25
11. 32	22. 32	33. 63	44. 26

**Problem Set**

1.
  - a. Arrow way shown; 370; 300; 280
  - b. Arrow way shown; 360; 300; 280
  - c. Arrow way shown; 450; 400; 370
  - d. Arrow way shown; 500; 460; 430
2.
  - a. 130; 100; 70
  - b. 400; 290; 270
  - c. 400; 390; 350
  - d. 300; 90; 50
3.
  - a. 68 tens
  - b. 60 tens
  - c. 59 tens
  - d. 56 tens
  - e. 600
  - f. 560

**Exit Ticket**

1. 300; 80; 50
2.
  - a. 37; 370
  - b. 30; 300
  - c. 28; 280

**Homework**

1.
  - a. Arrow way shown; 230; 200; 190
  - b. Arrow way shown; 270; 200; 180
  - c. Arrow way shown; 350; 300; 270
  - d. Arrow way shown; 610; 580; 460
2.
  - a. 130; 100; 70
  - b. 200; 180; 150
  - c. 300; 290; 270
  - d. 500; 490; 480
3.
  - a. 36 tens
  - b. 30 tens
  - c. 28 tens
  - d. 28 tens
  - e. 280
  - f. 360

## Lesson 5

### Problem Set

- 300
  - 430
  - 30
  - 31
  - 43
  - 54
- Number bond drawn and equations will vary.
  - 320
  - 450
  - 510
  - 720
  - 285
  - 355
  - 822

### Exit Ticket

- Number bond drawn and equations will vary.
  - 600
  - 855
- 91 tens

### Homework

- 320
  - 520
  - 30
  - 32
  - 51
  - 52
- Number bond drawn and equations will vary.
  - 270
  - 650
  - 820
  - 810
  - 240
  - 374
  - 951

## Lesson 6

### Problem Set

- Tape diagram drawn and labeled; equations will vary.
  - 30
  - 130
  - 120
  - 190
  - 260
- Tape diagram drawn and labeled; equations will vary.
  - 252; 452
  - 263; 563
  - 134; 434
  - 317; 617

### Exit Ticket

Tape diagram drawn and labeled; equations will vary.

- 165
- 272
- 372

### Homework

- Tape diagram drawn and labeled; equations will vary.
  - 150
  - 230
  - 220
  - 370
  - 470
- Tape diagram drawn and labeled; equations will vary.
  - 137; 237
  - 173; 373
  - 144; 444
  - 328; 728

## Lesson 7

### Problem Set

1. First and third student work examples circled  
Answers will vary.
2. Tape diagram student work example circled  
Answers will vary.
3. Answers will vary.
4. a. Answers will vary.  
b. Strategies will vary; 664  
c. Answers will vary.

### Exit Ticket

- a. Answers will vary.
- b. Strategies will vary; 953
- c. Answers will vary.

### Homework

1. a. 670  
b. 362  
c. 312  
d. 40  
e. 460  
f. 160
2. a. 190  
b. 180  
c. 360
3. a. Strategies will vary; 962  
b. Strategies will vary; 962  
c. Answers will vary.
4. a. Answers will vary.  
b. Strategies will vary; 677  
c. Answers will vary.

## Lesson 8

### Sprint

#### Side A

1. 39	12. 54	23. 92	34. 52
2. 49	13. 60	24. 94	35. 60
3. 59	14. 61	25. 80	36. 61
4. 69	15. 62	26. 81	37. 60
5. 39	16. 64	27. 82	38. 62
6. 49	17. 70	28. 85	39. 60
7. 59	18. 61	29. 70	40. 62
8. 69	19. 62	30. 71	41. 80
9. 50	20. 64	31. 84	42. 82
10. 51	21. 90	32. 50	43. 40
11. 52	22. 91	33. 51	44. 43

#### Side B

1. 29	12. 44	23. 82	34. 42
2. 39	13. 50	24. 84	35. 50
3. 49	14. 51	25. 70	36. 51
4. 59	15. 52	26. 71	37. 50
5. 29	16. 54	27. 72	38. 52
6. 39	17. 60	28. 75	39. 60
7. 49	18. 61	29. 60	40. 62
8. 59	19. 62	30. 61	41. 70
9. 40	20. 64	31. 62	42. 72
10. 41	21. 80	32. 40	43. 90
11. 42	22. 81	33. 41	44. 93



**Problem Set**

1.
  - a. Vertical form shown; 350
  - b. Vertical form shown; 450
  - c. Vertical form shown; 408
  - d. Vertical form shown; 408
  - e. Vertical form shown; 891
  - f. Vertical form shown; 791
  - g. Vertical form shown; 909
  - h. Vertical form shown; 909
2.
  - a. 500
  - b. 520
  - c. 550
  - d. 600
  - e. 614
  - f. 680
  - g. 780
  - h. 800
  - i. 900
  - j. 910

**Exit Ticket**

1. Vertical form shown; 491
2. Vertical form shown; 319

**Homework**

1.
  - a. Vertical form shown; 580
  - b. Vertical form shown; 690
  - c. Vertical form shown; 407
  - d. Vertical form shown; 809
  - e. Vertical form shown; 690
  - f. Vertical form shown; 580
  - g. Vertical form shown; 609
  - h. Vertical form shown; 960
2.
  - a. 600
  - b. 620
  - c. 660
  - d. 700
  - e. 710
  - f. 560
  - g. 660
  - h. 700
  - i. 800
  - j. 810

## Lesson 9

### Problem Set

- Vertical form shown; 710
  - Vertical form shown; 711
  - Vertical form shown; 611
  - Vertical form shown; 811
  - Vertical form shown; 780
  - Vertical form shown; 780
  - Vertical form shown; 1000
  - Vertical form shown; 940
- 700
  - 700
  - 700
  - 701
  - 711
  - 781
  - 801

### Exit Ticket

- Vertical form shown; 572
- Vertical form shown; 522

### Homework

- Vertical form shown; 550
  - Vertical form shown; 771
  - Vertical form shown; 780
  - Vertical form shown; 692
  - Vertical form shown; 780
  - Vertical form shown; 801
  - Vertical form shown; 910
  - Vertical form shown; 921
- 600
  - 620
  - 600
  - 710
  - 610
  - 700
  - 710

## Lesson 10

### Sprint

#### Side A

1. 10	12. 31	23. 24	34. 35
2. 20	13. 22	24. 34	35. 21
3. 40	14. 32	25. 24	36. 22
4. 10	15. 22	26. 34	37. 23
5. 20	16. 32	27. 25	38. 31
6. 40	17. 23	28. 26	39. 32
7. 11	18. 33	29. 35	40. 22
8. 21	19. 23	30. 36	41. 31
9. 31	20. 33	31. 24	42. 23
10. 11	21. 21	32. 25	43. 27
11. 21	22. 21	33. 34	44. 37

#### Side B

1. 10	12. 31	23. 24	34. 36
2. 20	13. 22	24. 34	35. 21
3. 40	14. 32	25. 24	36. 22
4. 10	15. 22	26. 34	37. 23
5. 20	16. 32	27. 25	38. 34
6. 40	17. 23	28. 26	39. 34
7. 11	18. 33	29. 35	40. 32
8. 21	19. 23	30. 36	41. 21
9. 31	20. 33	31. 25	42. 33
10. 11	21. 21	32. 26	43. 37
11. 21	22. 31	33. 35	44. 27

**Problem Set**

1.
  - a. Chips drawn in place value chart and vertical form shown; 287
  - b. Chips drawn in place value chart and vertical form shown; 390
  - c. Chips drawn in place value chart and vertical form shown; 504
  - d. Chips drawn in place value chart and vertical form shown; 773
2.
  - a. Chips drawn in place value chart and vertical form shown; 738
  - b. Chips drawn in place value chart and vertical form shown; 821

**Exit Ticket**

1. Chips drawn in place value chart and vertical form shown; 945
2. Chips drawn in place value chart and vertical form shown; 945

**Homework**

1.
  - a. Chips drawn in place value chart and vertical form shown; 384
  - b. Chips drawn in place value chart and vertical form shown; 750
  - c. Chips drawn in place value chart and vertical form shown; 605
  - d. Chips drawn in place value chart and vertical form shown; 900
2.
  - a. Chips drawn in place value chart and vertical form shown; 490
  - b. Chips drawn in place value chart and vertical form shown; 481

## Lesson 11

### Problem Set

- Chips drawn in place value chart and vertical form shown; 410
  - Chips drawn in place value chart and vertical form shown; 712
  - Chips drawn in place value chart and vertical form shown; 936
  - Chips drawn in place value chart and vertical form shown; 937
- Chips drawn in place value chart and vertical form shown; 494
  - Chips drawn in place value chart and vertical form shown; 605

### Exit Ticket

- Chips drawn in place value chart and vertical form shown; 623
- Chips drawn in place value chart and vertical form shown; 902

### Homework

- Chips drawn in place value chart and vertical form shown; 391
  - Chips drawn in place value chart and vertical form shown; 763
  - Chips drawn in place value chart and vertical form shown; 851
  - Chips drawn in place value chart and vertical form shown; 936
- Chips drawn in place value chart and vertical form shown; 834
  - Chips drawn in place value chart and vertical form shown; 754

## Lesson 12

### Sprint

#### Side A

1. 101	12. 105	23. 111	34. 166
2. 102	13. 107	24. 122	35. 175
3. 103	14. 104	25. 133	36. 167
4. 106	15. 106	26. 144	37. 176
5. 104	16. 111	27. 155	38. 194
6. 107	17. 122	28. 166	39. 192
7. 105	18. 133	29. 177	40. 194
8. 101	19. 144	30. 134	41. 193
9. 102	20. 155	31. 143	42. 194
10. 103	21. 166	32. 145	43. 192
11. 108	22. 177	33. 154	44. 186

#### Side B

1. 101	12. 107	23. 111	34. 156
2. 102	13. 105	24. 122	35. 165
3. 103	14. 106	25. 133	36. 177
4. 107	15. 104	26. 144	37. 186
5. 105	16. 111	27. 155	38. 192
6. 108	17. 122	28. 166	39. 194
7. 104	18. 133	29. 177	40. 196
8. 106	19. 144	30. 124	41. 191
9. 101	20. 155	31. 133	42. 192
10. 102	21. 166	32. 135	43. 194
11. 103	22. 177	33. 144	44. 184

**Problem Set**

1. Explanations will vary.
2.
  - a. 719; strategies and explanations will vary.
  - b. 667; strategies and explanations will vary.
  - c. 842; strategies and explanations will vary.

**Exit Ticket**

1. 765; strategies and explanations will vary.
2. 824; strategies and explanations will vary.

**Homework**

1.
  - a. 725; strategies will vary.
  - b. 725; strategies will vary.
  - c. Explanations will vary.
2.
  - a. 757; strategies and explanations will vary.
  - b. 943; strategies and explanations will vary.
  - c. 761; strategies and explanations will vary.

## Lesson 13

### Problem Set

- 2; 20; 120; 121
  - 3; 30; 730; 732
- Answer provided
  - $119; 119 + 19 = 138$
  - $410; 410 + 35 = 445$
  - $392; 392 + 53 = 445$
  - $693; 693 + 170 = 863$
  - $693; 693 + 152 = 845$
  - $244; 244 + 228 = 472$
  - $144; 144 + 274 = 418$
  - $383; 383 + 184 = 567$
  - $419; 419 + 148 = 567$

### Exit Ticket

- 261;  $261 + 117 = 378$
- 259;  $259 + 119 = 378$
- 420;  $420 + 433 = 853$
- 305;  $305 + 548 = 853$

### Homework

- 4, 40, 140, 141
  - 3, 30, 330, 331
- Answer provided
  - $115; 115 + 38 = 153$
  - $313; 313 + 49 = 362$
  - $308; 308 + 177 = 485$
  - $463; 463 + 290 = 753$
  - $277; 277 + 290 = 567$
  - $445; 445 + 428 = 873$
  - $252; 252 + 565 = 817$
  - $292; 292 + 681 = 973$
  - $509; 509 + 239 = 748$
- 534, 319



## Lesson 14

### Core Fluency Practice

#### Set A

- |        |        |        |        |
|--------|--------|--------|--------|
| 1. 12  | 11. 18 | 21. 11 | 31. 11 |
| 2. 15  | 12. 18 | 22. 12 | 32. 16 |
| 3. 11  | 13. 19 | 23. 14 | 33. 14 |
| 4. 18  | 14. 18 | 24. 12 | 34. 14 |
| 5. 17  | 15. 11 | 25. 12 | 35. 15 |
| 6. 13  | 16. 18 | 26. 13 | 36. 13 |
| 7. 14  | 17. 15 | 27. 11 | 37. 11 |
| 8. 17  | 18. 17 | 28. 14 | 38. 12 |
| 9. 19  | 19. 15 | 29. 10 | 39. 14 |
| 10. 19 | 20. 16 | 30. 13 | 40. 13 |

#### Set B

- |        |        |        |        |
|--------|--------|--------|--------|
| 1. 17  | 11. 17 | 21. 13 | 31. 13 |
| 2. 19  | 12. 18 | 22. 13 | 32. 5  |
| 3. 12  | 13. 20 | 23. 8  | 33. 16 |
| 4. 15  | 14. 12 | 24. 6  | 34. 12 |
| 5. 14  | 15. 16 | 25. 8  | 35. 12 |
| 6. 16  | 16. 7  | 26. 7  | 36. 12 |
| 7. 19  | 17. 7  | 27. 17 | 37. 8  |
| 8. 4   | 18. 7  | 28. 12 | 38. 9  |
| 9. 2   | 19. 16 | 29. 12 | 39. 9  |
| 10. 18 | 20. 15 | 30. 12 | 40. 10 |

**Set C**

- |       |        |       |        |
|-------|--------|-------|--------|
| 1. 10 | 11. 9  | 21. 8 | 31. 8  |
| 2. 10 | 12. 9  | 22. 9 | 32. 5  |
| 3. 7  | 13. 12 | 23. 8 | 33. 9  |
| 4. 2  | 14. 9  | 24. 9 | 34. 5  |
| 5. 10 | 15. 8  | 25. 9 | 35. 13 |
| 6. 1  | 16. 8  | 26. 8 | 36. 5  |
| 7. 10 | 17. 11 | 27. 7 | 37. 13 |
| 8. 10 | 18. 9  | 28. 5 | 38. 2  |
| 9. 10 | 19. 7  | 29. 7 | 39. 4  |
| 10. 7 | 20. 7  | 30. 9 | 40. 4  |

**Set D**

- |        |        |        |        |
|--------|--------|--------|--------|
| 1. 10  | 11. 9  | 21. 7  | 31. 4  |
| 2. 5   | 12. 11 | 22. 6  | 32. 9  |
| 3. 6   | 13. 9  | 23. 11 | 33. 9  |
| 4. 2   | 14. 7  | 24. 6  | 34. 8  |
| 5. 6   | 15. 9  | 25. 8  | 35. 7  |
| 6. 3   | 16. 10 | 26. 3  | 36. 9  |
| 7. 10  | 17. 8  | 27. 5  | 37. 14 |
| 8. 10  | 18. 9  | 28. 8  | 38. 2  |
| 9. 2   | 19. 8  | 29. 8  | 39. 17 |
| 10. 10 | 20. 7  | 30. 7  | 40. 9  |

**Set E**

- |       |        |        |        |
|-------|--------|--------|--------|
| 1. 14 | 11. 8  | 21. 6  | 31. 7  |
| 2. 19 | 12. 9  | 22. 3  | 32. 2  |
| 3. 20 | 13. 16 | 23. 8  | 33. 9  |
| 4. 18 | 14. 13 | 24. 18 | 34. 9  |
| 5. 15 | 15. 13 | 25. 15 | 35. 8  |
| 6. 15 | 16. 12 | 26. 20 | 36. 13 |
| 7. 11 | 17. 11 | 27. 14 | 37. 11 |
| 8. 7  | 18. 5  | 28. 16 | 38. 15 |
| 9. 4  | 19. 7  | 29. 12 | 39. 13 |
| 10. 8 | 20. 6  | 30. 6  | 40. 20 |

**Problem Set**

- Place value disks drawn on a chart; addition check provided; 299
  - Place value disks drawn on a chart; addition check provided; 307
  - Place value disks drawn on a chart; addition check provided; 389
  - Place value disks drawn on a chart; addition check provided; 454
  - Place value disks drawn on a chart; addition check provided; 299
- Answers will vary.

**Exit Ticket**

- Place value disks drawn on a chart; addition check provided; 95
- Place value disks drawn on a chart; addition check provided; 293

**Homework**

1.
  - a. Place value disks drawn on a chart; addition check provided; 193
  - b. Place value disks drawn on a chart; addition check provided; 106
  - c. Place value disks drawn on a chart; addition check provided; 139
  - d. Place value disks drawn on a chart; addition check provided; 188
  - e. Place value disks drawn on a chart; addition check provided; 9
2. Answers will vary.

## Lesson 15

### Problem Set

- Chips drawn on place value chart; addition check provided; 489
  - Chips drawn on place value chart; addition check provided; 371
  - Chips drawn on place value chart; addition check provided; 489
  - Chips drawn on place value chart; addition check provided; 298
  - Chips drawn on place value chart; addition check provided; 355
- Number bond drawn; 589; 762
  - Number bond drawn; 358; 358

### Exit Ticket

- Chips drawn on place value chart; addition check provided; 256
- Chips drawn on place value chart; addition check provided; 236

### Homework

- Chips drawn on place value chart; addition check provided; 125
  - Chips drawn on place value chart; addition check provided; 247
  - Chips drawn on place value chart; addition check provided; 367
  - Chips drawn on place value chart; addition check provided; 479
  - Chips drawn on place value chart; addition check provided; 313
- Number bond drawn; 409; 928
  - Number bond drawn; 373; 373

## Lesson 16

### Sprint

#### Side A

- |       |        |        |        |
|-------|--------|--------|--------|
| 1. 1  | 12. 3  | 23. 10 | 34. 8  |
| 2. 2  | 13. 10 | 24. 9  | 35. 10 |
| 3. 3  | 14. 9  | 25. 8  | 36. 9  |
| 4. 9  | 15. 8  | 26. 6  | 37. 8  |
| 5. 10 | 16. 7  | 27. 10 | 38. 7  |
| 6. 10 | 17. 5  | 28. 9  | 39. 7  |
| 7. 10 | 18. 10 | 29. 8  | 40. 4  |
| 8. 10 | 19. 9  | 30. 7  | 41. 9  |
| 9. 9  | 20. 8  | 31. 5  | 42. 2  |
| 10. 8 | 21. 7  | 32. 10 | 43. 7  |
| 11. 7 | 22. 3  | 33. 9  | 44. 6  |

#### Side B

- |       |        |        |        |
|-------|--------|--------|--------|
| 1. 10 | 12. 4  | 23. 10 | 34. 8  |
| 2. 10 | 13. 10 | 24. 9  | 35. 7  |
| 3. 10 | 14. 9  | 25. 8  | 36. 10 |
| 4. 10 | 15. 8  | 26. 7  | 37. 9  |
| 5. 1  | 16. 7  | 27. 5  | 38. 8  |
| 6. 2  | 17. 4  | 28. 10 | 39. 6  |
| 7. 3  | 18. 10 | 29. 9  | 40. 9  |
| 8. 8  | 19. 9  | 30. 8  | 41. 3  |
| 9. 9  | 20. 8  | 31. 6  | 42. 6  |
| 10. 8 | 21. 7  | 32. 10 | 43. 3  |
| 11. 7 | 22. 4  | 33. 9  | 44. 7  |

**Problem Set**

1.
  - a. Chips drawn on place value chart; 251
  - b. Chips drawn on place value chart; 219
  - c. Chips drawn on place value chart; 185
  - d. Chips drawn on place value chart; 191
  - e. Chips drawn on place value chart; 274
2. Answers will vary.

**Exit Ticket**

1. Chips drawn on place value chart; 461
2. Chips drawn on place value chart; 132

**Homework**

1.
  - a. Chips drawn on place value chart; 117
  - b. Chips drawn on place value chart; 138
  - c. Chips drawn on place value chart; 319
  - d. Chips drawn on place value chart; 192
  - e. Chips drawn on place value chart; 328
2. Answers will vary.

## Lesson 17

### Sprint

#### Side A

- |        |        |        |        |
|--------|--------|--------|--------|
| 1. 9   | 12. 58 | 23. 15 | 34. 9  |
| 2. 8   | 13. 6  | 24. 85 | 35. 79 |
| 3. 18  | 14. 7  | 25. 3  | 36. 8  |
| 4. 38  | 15. 17 | 26. 4  | 37. 68 |
| 5. 8   | 16. 67 | 27. 24 | 38. 8  |
| 6. 9   | 17. 5  | 28. 2  | 39. 78 |
| 7. 19  | 18. 6  | 29. 3  | 40. 7  |
| 8. 49  | 19. 16 | 30. 33 | 41. 87 |
| 9. 7   | 20. 76 | 31. 1  | 42. 9  |
| 10. 8  | 21. 4  | 32. 2  | 43. 39 |
| 11. 18 | 22. 5  | 33. 42 | 44. 59 |

#### Side B

- |        |        |        |        |
|--------|--------|--------|--------|
| 1. 8   | 12. 68 | 23. 15 | 34. 9  |
| 2. 18  | 13. 6  | 24. 35 | 35. 89 |
| 3. 28  | 14. 7  | 25. 3  | 36. 8  |
| 4. 48  | 15. 17 | 26. 4  | 37. 38 |
| 5. 8   | 16. 77 | 27. 44 | 38. 8  |
| 6. 9   | 17. 5  | 28. 2  | 39. 58 |
| 7. 19  | 18. 6  | 29. 3  | 40. 7  |
| 8. 59  | 19. 16 | 30. 53 | 41. 77 |
| 9. 7   | 20. 86 | 31. 1  | 42. 9  |
| 10. 8  | 21. 4  | 32. 2  | 43. 69 |
| 11. 18 | 22. 5  | 33. 22 | 44. 49 |



**Problem Set**

1.
  - a. Chips drawn on place value chart; 87
  - b. Chips drawn on place value chart; 153
  - c. Chips drawn on place value chart; 272
  - d. Chips drawn on place value chart; 194
  - e. Chips drawn on place value chart; 497
2.  $600 - 367 = 233$ ;  $233 + 367 = 600$

**Exit Ticket**

1. Chips drawn on place value chart; 168
2. Chips drawn on place value chart; 49

**Homework**

1.
  - a. Chips drawn on place value chart; 77
  - b. Chips drawn on place value chart; 181
  - c. Chips drawn on place value chart; 158
  - d. Chips drawn on place value chart; 391
  - e. Chips drawn on place value chart; 299
2.  $800 - 567 = 233$ ;  $233 + 567 = 800$

## Lesson 18

### Problem Set

- Arrow way shown; 53
  - Arrow way shown; 135
- Chips drawn in place value chart and vertical form shown; 148
  - Chips drawn in place value chart and vertical form shown; 179
- 163; strategies and explanations will vary.
  - 211; strategies and explanations will vary.
- 257; 257
- 53
  - 187

### Exit Ticket

- 135; strategies and explanations will vary.
- 309; strategies and explanations will vary.

### Homework

- Arrow way shown; 238
  - Arrow way shown; 668
- Chips drawn in place value chart and vertical form shown; 440
  - Chips drawn in place value chart and vertical form shown; 136
- 310; strategies and explanations will vary.
  - 262; strategies and explanations will vary.
- Explanations will vary.
- Simplifying strategy used; 222

## Lesson 19

### Problem Set

- Explanations will vary.
- 610; strategies and explanations will vary.
  - 197; strategies and explanations will vary.
  - 610; strategies and explanations will vary.
  - 211; strategies and explanations will vary.

### Exit Ticket

- 990; strategies and explanations will vary.
- 278; strategies and explanations will vary.

### Homework

- 590; strategies and explanations will vary.
  - 840; strategies and explanations will vary.
  - 861; strategies and explanations will vary.
  - 174; strategies and explanations will vary.
  - 244; strategies and explanations will vary.
  - 509; strategies and explanations will vary.

## Lesson 20

### Problem Set

- 636
  - Strategies will vary.
  - Strategies will vary.
- 102
  - Strategies will vary.
  - Strategies will vary.
- 729
  - Strategies will vary.
  - Strategies will vary.
- 394
  - Strategies will vary.
  - Strategies will vary.
- 172
  - Strategies will vary.
  - Strategies will vary.

### Exit Ticket

- 455
  - Strategies will vary.
  - Strategies will vary.
- 294
  - Strategies will vary.
  - Strategies will vary.

### Homework

- 700
  - Strategies will vary.
  - Strategies will vary.
- 247
  - Strategies will vary.
  - Strategies will vary.
- Strategy circled
  - Circled strategy used to solve; 417
  - Explanations will vary.
- Strategy circled
  - Circled strategy used to solve; 157
  - Explanations will vary.

## Credits

Great Minds® has made every effort to obtain permission for the reprinting of all copyrighted material. If any owner of copyrighted material is not acknowledged herein, please contact Great Minds for proper acknowledgment in all future editions and reprints of this module.

- All material from the *Common Core State Standards for Mathematics* © Copyright 2010 National Governors Association Center for Best Practices and Council of Chief State School Officers. All rights reserved.

**This page intentionally left blank**