

## Teacher Edition

# Eureka Math Grade 7 Module 1

Special thanks go to the Gordon A. Cain Center and to the Department of Mathematics at Louisiana State University for their support in the development of *Eureka Math*.

For a free *Eureka Math* Teacher  
Resource Pack, Parent Tip  
Sheets, and more please  
visit [www.Eureka.tools](http://www.Eureka.tools)

**Published by Great Minds®.**

Copyright © 2018 Great Minds®. No part of this work may be reproduced, sold, or commercialized, in whole or in part, without written permission from Great Minds®. Noncommercial use is licensed pursuant to a Creative Commons Attribution-NonCommercial-ShareAlike 4.0 license; for more information, go to <http://greatminds.org/copyright>. *Great Minds* and *Eureka Math* are registered trademarks of Great Minds®.

Printed in the U.S.A.

This book may be purchased from the publisher at [eureka-math.org](http://eureka-math.org).

10 9 8 7 6 5 4 3 2 1

ISBN 978-1-64054-355-3

G7-M1-UTE-1.3.0-05.2018

### ***Eureka Math: A Story of Ratios Contributors***

Michael Allwood, Curriculum Writer  
Tiah Alphonso, Program Manager—Curriculum Production  
Catriona Anderson, Program Manager—Implementation Support  
Beau Bailey, Curriculum Writer  
Scott Baldrige, Lead Mathematician and Lead Curriculum Writer  
Bonnie Bergstresser, Math Auditor  
Gail Burrill, Curriculum Writer  
Beth Chance, Statistician  
Joanne Choi, Curriculum Writer  
Jill Diniz, Program Director  
Lori Fanning, Curriculum Writer  
Ellen Fort, Math Auditor  
Kathy Fritz, Curriculum Writer  
Glenn Gebhard, Curriculum Writer  
Krysta Gibbs, Curriculum Writer  
Winnie Gilbert, Lead Writer / Editor, Grade 8  
Pam Goodner, Math Auditor  
Debby Grawn, Curriculum Writer  
Bonnie Hart, Curriculum Writer  
Stefanie Hassan, Lead Writer / Editor, Grade 8  
Sherri Hernandez, Math Auditor  
Bob Hollister, Math Auditor  
Patrick Hopfensperger, Curriculum Writer  
Sunil Koswatta, Mathematician, Grade 8  
Brian Kotz, Curriculum Writer  
Henry Kranendonk, Lead Writer / Editor, Statistics  
Connie Laughlin, Math Auditor  
Jennifer Loftin, Program Manager—Professional Development  
Nell McAnelly, Project Director  
Ben McCarty, Mathematician  
Stacie McClintock, Document Production Manager  
Saki Milton, Curriculum Writer  
Pia Mohsen, Curriculum Writer  
Jerry Moreno, Statistician  
Ann Netter, Lead Writer / Editor, Grades 6–7  
Sarah Oyler, Document Coordinator  
Roxy Peck, Statistician, Lead Writer / Editor, Statistics  
Terrie Poehl, Math Auditor  
Kristen Riedel, Math Audit Team Lead  
Spencer Roby, Math Auditor  
Kathleen Scholand, Math Auditor  
Erika Silva, Lead Writer / Editor, Grade 6–7  
Robyn Sorenson, Math Auditor  
Hester Sutton, Advisor / Reviewer Grades 6–7  
Shannon Vinson, Lead Writer / Editor, Statistics  
Allison Witcraft, Math Auditor

Julie Wortmann, Lead Writer / Editor, Grade 7

David Wright, Mathematician, Lead Writer / Editor, Grades 6–7

## **Board of Trustees**

Lynne Munson, President and Executive Director of Great Minds

Nell McAnelly, Chairman, Co-Director Emeritus of the Gordon A. Cain Center for STEM Literacy at Louisiana State University

William Kelly, Treasurer, Co-Founder and CEO at ReelDx

Jason Griffiths, Secretary, Director of Programs at the National Academy of Advanced Teacher Education

Pascal Forgione, Former Executive Director of the Center on K-12 Assessment and Performance Management at ETS

Lorraine Griffith, Title I Reading Specialist at West Buncombe Elementary School in Asheville, North Carolina

Bill Honig, President of the Consortium on Reading Excellence (CORE)

Richard Kessler, Executive Dean of Mannes College the New School for Music

Chi Kim, Former Superintendent, Ross School District

Karen LeFever, Executive Vice President and Chief Development Officer at ChanceLight Behavioral Health and Education

Maria Neira, Former Vice President, New York State United Teachers

**This page intentionally left blank**

Table of Contents<sup>1</sup>

## Ratios and Proportional Relationships

<b>Module Overview</b> .....	2
Topic A: Proportional Relationships .....	10
Lesson 1: An Experience in Relationships as Measuring Rate .....	11
Lesson 2: Proportional Relationships .....	19
Lessons 3–4: Identifying Proportional and Non-Proportional Relationships in Tables .....	26
Lessons 5–6: Identifying Proportional and Non-Proportional Relationships in Graphs .....	41
Topic B: Unit Rate and the Constant of Proportionality .....	58
Lesson 7: Unit Rate as the Constant of Proportionality .....	60
Lessons 8–9: Representing Proportional Relationships with Equations .....	67
Lesson 10: Interpreting Graphs of Proportional Relationships .....	86
<b>Mid-Module Assessment and Rubric</b> .....	95
<i>Topics A through B (assessment 1 day, return 1 day, remediation or further applications 2 days)</i>	
Topic C: Ratios and Rates Involving Fractions .....	103
Lessons 11–12: Ratios of Fractions and Their Unit Rates .....	105
Lesson 13: Finding Equivalent Ratios Given the Total Quantity .....	119
Lesson 14: Multi-Step Ratio Problems .....	128
Lesson 15: Equations of Graphs of Proportional Relationships Involving Fractions .....	135
Topic D: Ratios of Scale Drawings .....	143
Lesson 16: Relating Scale Drawings to Ratios and Rates .....	144
Lesson 17: The Unit Rate as the Scale Factor .....	157
Lesson 18: Computing Actual Lengths from a Scale Drawing .....	167
Lesson 19: Computing Actual Areas from a Scale Drawing .....	177
Lesson 20: An Exercise in Creating a Scale Drawing .....	187
Lessons 21–22: An Exercise in Changing Scales .....	196
<b>End-of-Module Assessment and Rubric</b> .....	211
<i>Topics A through D (assessment 1 day, return 1 day, remediation or further applications 2 days)</i>	

<sup>1</sup>Each lesson is ONE day, and ONE day is considered a 45-minute period.

## Grade 7 • Module 1

# Ratios and Proportional Relationships

## OVERVIEW

In Module 1, students build upon their Grade 6 reasoning about ratios, rates, and unit rates to formally define proportional relationships and the constant of proportionality. In Topic A, students examine situations carefully to determine if they are describing a proportional relationship. Their analysis is applied to relationships given in tables, graphs, and verbal descriptions.

In Topic B, students learn that the unit rate of a collection of equivalent ratios is called the *constant of proportionality* and can be used to represent proportional relationships with equations of the form  $y = kx$ , where  $k$  is the constant of proportionality. Students relate the equation of a proportional relationship to ratio tables and to graphs and interpret the points on the graph within the context of the situation.

In Topic C, students extend their reasoning about ratios and proportional relationships to compute unit rates for ratios and rates specified by rational numbers, such as a speed of  $\frac{1}{2}$  mile per  $\frac{1}{4}$  hour. Students apply their experience in the first two topics and their new understanding of unit rates for ratios and rates involving fractions to solve multi-step ratio word problems.

In the final topic of this module, students bring the sum of their experience with proportional relationships to the context of scale drawings. Given a scale drawing, students rely on their background in working with side lengths and areas of polygons as they identify the scale factor as the constant of proportionality, calculate the actual lengths and areas of objects in the drawing, and create their own scale drawings of a two-dimensional view of a room or building. The topic culminates with a two-day experience of students creating a new scale drawing by changing the scale of an existing drawing.

Later in the year, in Module 4, students extend the concepts of this module to percent problems.

The module is composed of 22 lessons; 8 days are reserved for administering the Mid- and End-of-Module Assessments, returning the assessments, and remediating or providing further applications of the concepts. The Mid-Module Assessment follows Topic B. The End-of-Module Assessment follows Topic D.



## Focus Standards

### Analyze proportional relationships and use them to solve real-world and mathematical problems.

- Compute unit rates associated with ratios of fractions, including ratios of lengths, areas and other quantities measured in like or different units. *For example, if a person walks  $\frac{1}{2}$  mile in each  $\frac{1}{4}$  hour, compute the unit rate as the complex fraction  $\frac{1/2}{1/4}$  miles per hour, equivalently 2 miles per hour.*
- Recognize and represent proportional relationships between quantities.
  - Decide whether two quantities are in a proportional relationship, e.g., by testing for equivalent ratios in a table or graphing on a coordinate plane and observing whether the graph is a straight line through the origin.
  - Identify the constant of proportionality (unit rate) in tables, graphs, equations, diagrams, and verbal descriptions of proportional relationships.
  - Represent proportional relationships by equations. *For example, if total cost  $t$  is proportional to the number  $n$  of items purchased at a constant price  $p$ , the relationship between the total cost and the number of items can be expressed as  $t = pn$ .*
  - Explain what a point  $(x, y)$  on the graph of a proportional relationship means in terms of the situation, with special attention to the points  $(0,0)$  and  $(1, r)$ , where  $r$  is the unit rate.
- Use proportional relationships to solve multistep ratio and percent problems. *Examples: simple interest, tax, markups and markdowns, gratuities and commissions, fees, percent increase and decrease, percent error.*

### Solve real-life and mathematical problems using numerical and algebraic expressions and equations.

- Use variables to represent quantities in a real-world or mathematical problem, and construct simple equations and inequalities to solve problems by reasoning about the quantities.
  - Solve word problems leading to equations of the form  $px + q = r$  and  $p(x + q) = r$ , where  $p$ ,  $q$ , and  $r$  are specific rational numbers. Solve equations of these forms fluently. Compare an algebraic solution to an arithmetic solution, identifying the sequence of the operations used in each approach. *For example, the perimeter of a rectangle is 54 cm. Its length is 6 cm. What is its width?*

**Draw, construct, and describe geometrical figures and describe the relationships between them.**

- Solve problems involving scale drawings of geometric figures, including computing actual lengths and areas from a scale drawing and reproducing a scale drawing at a different scale.

## Foundational Standards

**Understand ratio concepts and use ratio reasoning to solve problems.**

- Understand the concept of a ratio and use ratio language to describe a ratio relationship between two quantities. *For example, “The ratio of wings to beaks in the bird house at the zoo was 2: 1, because for every 2 wings there was 1 beak.” “For every vote candidate A received, candidate C received nearly three votes.”*
- Understand the concept of a unit rate  $a/b$  associated with a ratio  $a:b$  with  $b \neq 0$ , and use rate language in the context of a ratio relationship. *For example, “This recipe has a ratio of 3 cups of flour to 4 cups of sugar, so there is  $3/4$  cup of flour for each cup of sugar.” “We paid \$75 for 15 hamburgers, which is a rate of \$5 per hamburger.”<sup>2</sup>*
- Use ratio and rate reasoning to solve real-world and mathematical problems, e.g., by reasoning about tables of equivalent ratios, tape diagrams, double number line diagrams, or equations.
  - Make tables of equivalent ratios relating quantities with whole–number measurements, find missing values in the tables, and plot the pairs of values on the coordinate plane. Use tables to compare ratios.
  - Solve unit rate problems including those involving unit pricing and constant speed. *For example, if it took 7 hours to mow 4 lawns, then at that rate, how many lawns could be mowed in 35 hours? At what rate were lawns being mowed?*
  - Find a percent of a quantity as a rate per 100 (e.g., 30% of a quantity means  $30/100$  times the quantity); solve problems involving finding the whole, given a part and the percent.
  - Use ratio reasoning to convert measurement units; manipulate and transform units appropriately when multiplying or dividing quantities.

**Solve real-world and mathematical problems involving area, surface area, and volume.**

- Find the area of right triangles, other triangles, special quadrilaterals, and polygons by composing into rectangles or decomposing into triangles and other shapes; apply these techniques in the context of solving real-world and mathematical problems.

---

<sup>2</sup>Expectations for unit rates in this grade are limited to non-complex fractions.

- Draw polygons in the coordinate plane given coordinates for the vertices; use coordinates to find the length of a side joining points with the same first coordinate or the same second coordinate. Apply these techniques in the context of solving real-world and mathematical problems.

## Focus Standards for Mathematical Practice

- **Make sense of problems and persevere in solving them.** Students make sense of and solve multi-step ratio problems, including cases with pairs of rational number entries; they use representations, such as ratio tables, the coordinate plane, and equations, and relate these representations to each other and to the context of the problem. Students depict the meaning of constant of proportionality in proportional relationships, the importance of  $(0,0)$  and  $(1,r)$  on graphs, and the implications of how scale factors magnify or shrink actual lengths of figures on a scale drawing.
- **Reason abstractly and quantitatively.** Students compute unit rates for paired data given in tables to determine if the data represents a proportional relationship. Use of concrete numbers will be analyzed to create and implement equations, including  $y = kx$ , where  $k$  is the constant of proportionality. Students decontextualize a given constant speed situation, representing symbolically the quantities involved with the formula, distance = rate  $\times$  time. In scale drawings, scale factors will be changed to create additional scale drawings of a given picture.

## Terminology

### New or Recently Introduced Terms

- **Constant of Proportionality** (If a proportional relationship is described by the set of ordered pairs that satisfies the equation  $y = kx$ , where  $k$  is a positive constant, then  $k$  is called the *constant of proportionality*. For example, if the ratio of  $y$  to  $x$  is 2 to 3, then the constant of proportionality is  $\frac{2}{3}$ , and  $y = \frac{2}{3}x$ .)
- **Miles per Hour** (One *mile per hour* is a proportional relationship between  $d$  miles and  $t$  hours given by the equation  $d = 1 \cdot t$  (both  $d$  and  $t$  are positive real numbers). Similarly, for any positive real number  $v$ ,  $v$  *miles per hour* is a proportional relationship between  $d$  miles and  $t$  hours given by  $d = v \cdot t$ . The unit for the rate, mile per hour (or mile/hour) is often abbreviated as mph.)
- **One-To-One Correspondence Between Two Figures in the Plane (description)** (For two figures in the plane,  $S$  and  $S'$ , a *one-to-one correspondence between the figures* is a pairing between the points in  $S$  and the points in  $S'$  so that each point  $P$  of  $S$  is paired with one and only one point  $P'$  in  $S'$ , and likewise, each point  $Q'$  in  $S'$  is paired with one and only one point  $Q$  in  $S$ .)

- **Proportional Relationship (description)** (A *proportional relationship* is a correspondence between two types of quantities such that the measures of quantities of the first type are proportional to the measures of quantities of the second type.)

Note that proportional relationships and ratio relationships describe the same set of ordered pairs but in two different ways. Ratio relationships are used in the context of working with equivalent ratios, while proportional relationships are used in the context of rates.)

- **Proportional To (description)** (Measures of one type of quantity are *proportional to* measures of a second type of quantity if there is a number  $k$  so that for every measure  $x$  of a quantity of the first type, the corresponding measure  $y$  of a quantity of the second type is given by  $kx$ ; that is,  $y = kx$ . The number  $k$  is called the constant of proportionality.)
- **Scale Drawing and Scale Factor (description)** (For two figures in the plane,  $S$  and  $S'$ ,  $S'$  is said to be a *scale drawing* of  $S$  with *scale factor*  $r$  if there exists a one-to-one correspondence between  $S$  and  $S'$  so that, under the pairing of this one-to-one correspondence, the distance  $|PQ|$  between any two points  $P$  and  $Q$  of  $S$  is related to the distance  $|P'Q'|$  between corresponding points  $P'$  and  $Q'$  of  $S'$  by  $|P'Q'| = r|PQ|$ .)

### Familiar Terms and Symbols<sup>3</sup>

- Equivalent Ratio
- Rate
- Ratio
- Ratio Table
- Unit Rate

### Suggested Tools and Representations

- Ratio Table (See example below.)
- Coordinate Plane (See example below.)
- Equations of the Form  $y = kx$

Ratio Table

Sugar	Flour
2	3
4	6
6	9

Coordinate Plane

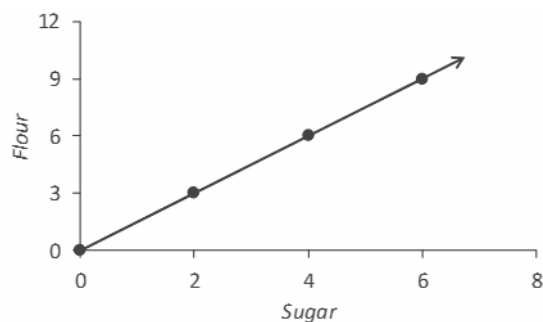

<sup>3</sup>These are terms and symbols students have seen previously.

## Preparing to Teach a Module

Preparation of lessons will be more effective and efficient if there has been an adequate analysis of the module first. Each module in *A Story of Ratios* can be compared to a chapter in a book. How is the module moving the plot, the mathematics, forward? What new learning is taking place? How are the topics and objectives building on one another? The following is a suggested process for preparing to teach a module.

Step 1: Get a preview of the plot.

- A: Read the Table of Contents. At a high level, what is the plot of the module? How does the story develop across the topics?
- B: Preview the module's Exit Tickets to see the trajectory of the module's mathematics and the nature of the work students are expected to be able to do.

Note: When studying a PDF file, enter "Exit Ticket" into the search feature to navigate from one Exit Ticket to the next.

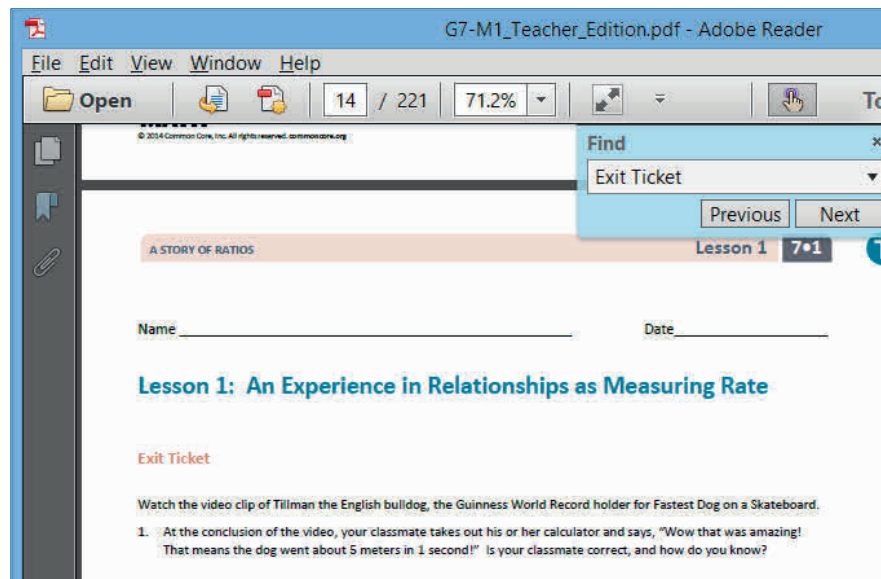

Step 2: Dig into the details.

- A: Dig into a careful reading of the Module Overview. While reading the narrative, liberally reference the lessons and Topic Overviews to clarify the meaning of the text – the lessons demonstrate the strategies, show how to use the models, clarify vocabulary, and build understanding of concepts.
- B: Having thoroughly investigated the Module Overview, read through the Student Outcomes of each lesson (in order) to further discern the plot of the module. How do the topics flow and tell a coherent story? How do the outcomes move students to new understandings?

Step 3: Summarize the story.

Complete the Mid- and End-of-Module Assessments. Use the strategies and models presented in the module to explain the thinking involved. Again, liberally reference the lessons to anticipate how students who are learning with the curriculum might respond.

## Preparing to Teach a Lesson

A three-step process is suggested to prepare a lesson. It is understood that at times teachers may need to make adjustments (customizations) to lessons to fit the time constraints and unique needs of their students. The recommended planning process is outlined below. Note: The ladder of Step 2 is a metaphor for the teaching sequence. The sequence can be seen not only at the macro level in the role that this lesson plays in the overall story, but also at the lesson level, where each rung in the ladder represents the next step in understanding or the next skill needed to reach the objective. To reach the objective, or the top of the ladder, all students must be able to access the first rung and each successive rung.

### Step 1: Discern the plot.

- A: Briefly review the module's Table of Contents, recalling the overall story of the module and analyzing the role of this lesson in the module.
- B: Read the Topic Overview related to the lesson, and then review the Student Outcome(s) and Exit Ticket of each lesson in the topic.
- C: Review the assessment following the topic, keeping in mind that assessments can be found midway through the module and at the end of the module.

### Step 2: Find the ladder.

- A: Work through the lesson, answering and completing each question, example, exercise, and challenge.
- B: Analyze and write notes on the new complexities or new concepts introduced with each question or problem posed; these notes on the sequence of new complexities and concepts are the rungs of the ladder.
- C: Anticipate where students might struggle, and write a note about the potential cause of the struggle.
- D: Answer the Closing questions, always anticipating how students will respond.

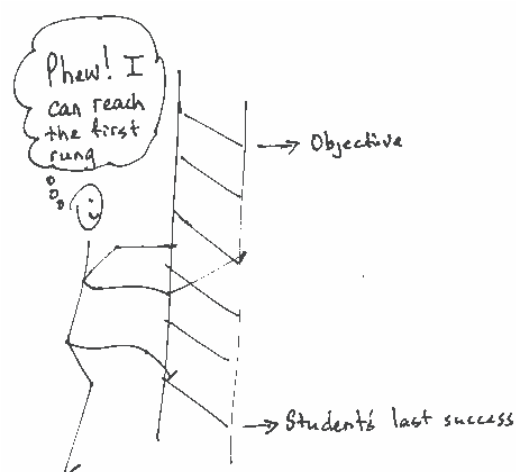

### Step 3: Hone the lesson.

Lessons may need to be customized if the class period is not long enough to do all of what is presented and/or if students lack prerequisite skills and understanding to move through the entire lesson in the time allotted. A suggestion for customizing the lesson is to first decide upon and designate each question, example, exercise, or challenge as either “Must Do” or “Could Do.”

- A: Select “Must Do” dialogue, questions, and problems that meet the Student Outcome(s) while still providing a coherent experience for students; reference the ladder. The expectation should be that the majority of the class will be able to complete the “Must Do” portions of the lesson within the allocated time. While choosing the “Must Do” portions of the lesson, keep in mind the need for a balance of dialogue and conceptual questioning, application problems, and abstract problems, and a balance between students using pictorial/graphical representations and abstract representations. Highlight dialogue to be included in the delivery of instruction so that students have a chance to articulate and consolidate understanding as they move through the lesson.

- B: “Must Do” portions might also include remedial work as necessary for the whole class, a small group, or individual students. Depending on the anticipated difficulties, the remedial work might take on different forms as suggested in the chart below.

Anticipated Difficulty	“Must Do” Remedial Problem Suggestion
The first problem of the lesson is too challenging.	Write a short sequence of problems on the board that provides a ladder to Problem 1. Direct students to complete those first problems to empower them to begin the lesson.
There is too big of a jump in complexity between two problems.	Provide a problem or set of problems that bridge student understanding from one problem to the next.
Students lack fluency or foundational skills necessary for the lesson.	Before beginning the lesson, do a quick, engaging fluency exercise, such as a Rapid White Board Exchange or Sprint. Before beginning any fluency activity for the first time, assess that students have conceptual understanding of the problems in the set and that they are poised for success with the easiest problem in the set.
More work is needed at the concrete or pictorial level.	Provide manipulatives or the opportunity to draw solution strategies.
More work is needed at the abstract level.	Add a White Board Exchange of abstract problems to be completed toward the end of the lesson.

- C: “Could Do” problems are for students who work with greater fluency and understanding and can, therefore, complete more work within a given time frame.
- D: At times, a particularly complex problem might be designated as a “Challenge!” problem to provide to advanced students. Consider creating the opportunity for students to share their “Challenge!” solutions with the class at a weekly session or on video.
- E: If the lesson is customized, be sure to carefully select Closing questions that reflect such decisions and adjust the Exit Ticket if necessary.

## Assessment Summary

Assessment Type	Administered	Format
Mid-Module Assessment Task	After Topic B	Constructed response with rubric
End-of-Module Assessment Task	After Topic D	Constructed response with rubric



## Topic A

## Proportional Relationships

- Focus Standard:**
- Recognize and represent proportional relationships between quantities.
    - Decide whether two quantities are in a proportional relationship, e.g., by testing for equivalent ratios in a table or graphing on a coordinate plane and observing whether the graph is a straight line through the origin.

**Instructional Days:** 6

**Lesson 1:** An Experience in Relationships as Measuring Rate (P)<sup>1</sup>

**Lesson 2:** Proportional Relationships (P)

**Lessons 3–4:** Identifying Proportional and Non-Proportional Relationships in Tables (P, P)

**Lessons 5–6:** Identifying Proportional and Non-Proportional Relationships in Graphs (E, E)

In Lesson 1 of Topic A, students are reintroduced to the meanings of value of a ratio, equivalent ratios, rate, and unit rate through a collaborative work task where they record their rates choosing an appropriate unit of rate measurement. In Lesson 2, students conceptualize that two quantities are proportional to each other when there exists a constant such that each measure in the first quantity multiplied by this constant gives the corresponding measure in the second quantity.

They then apply this basic understanding in Lessons 3–6 by examining situations to decide whether two quantities are in a proportional or non-proportional relationship by first checking for a constant multiple between measures of the two quantities, when given a table, and then by graphing on a coordinate plane. Students recognize that the graph of a proportional relationship must be a straight line through the origin.

<sup>1</sup>Lesson Structure Key: P-Problem Set Lesson, M-Modeling Cycle Lesson, E-Exploration Lesson, S-Socratic Lesson





## Lesson 1: An Experience in Relationships as Measuring Rate

### Student Outcomes

- Students compute unit rates associated with ratios of quantities measured in different units. Students use the context of the problem to recall the meanings of value of a ratio, equivalent ratios, rate, and unit rate, relating them to the context of the experience.

### Lesson Notes

The first example requires students to write ratios, equivalent ratios, rates, and unit rates. It is beneficial to introduce the description of these terms during the first year of implementation because the introduction is completed during Grade 6. To see how these terms are introduced, examine the first module of Grade 6.

For convenience, the descriptions of these terms provided in Grade 6 are listed on both the teacher and student pages.

### Classwork

#### Example 1 (15 minutes): How Fast Is Our Class?

To start this first class of the school year, conduct an exercise in how to pass out papers. The purpose of the task is not only to establish a routine at the start of the school year but also to provide a context to discuss ratio and rate.

Determine how papers will be passed out in class depending upon seating arrangement. For this task, it is best to divide the original stack so that one student (in each row or group) has a portion of the original stack. Based upon this determination, explain the system to students. A brief demonstration may help to provide a visual.

For example: If the room is arranged in rows, pass *across* the rows. Have students start on command and perhaps require that only the current paper-passing student may be out of his or her seat. If the room is arranged in groups or at tables, have the students pass papers to their left, on command, until everyone has a paper. *Note: This procedure is highly customizable for use in any classroom structure.*

Begin the task by handing a stack of papers to a starting person. Secretly start a stopwatch as the start command is given. Once every student has a paper, report the paper-passing time out loud. For example, "It took 12 seconds. Not bad, but let's see if we can get these papers passed out in 11 seconds next time."

Tell students to begin returning papers back in to the original stack, and then report the time upon completion.

- Excellent job. Now, pass them back out in 10 seconds. Excellent. Now, pass them back in 8 seconds.

Pose the following questions to the students as a whole group, one question at a time.

- How will we measure our rate of passing out papers?
  - *Using a stopwatch or similar tool to measure the number of seconds taken to pass out papers.*
- What quantities will we use to describe our rate?
  - *The number of papers passed out and the time that it took to pass them out.*

Complete the second and third columns (number of papers and time) on the table as a class.

- Describe the quantities you want to measure by talking about what units we use to measure each quantity.
  - *One quantity measures the number of papers, and the other measures the number of seconds.*

Review the Key Terms box defining ratio, rate, and unit rate in the student materials. Focus on reviewing the concept of ratio first, perhaps using a few quick examples.

#### Key Terms from Grade 6 Ratios and Unit Rates

A **ratio** is an ordered pair of numbers which are not both zero. A ratio is denoted  $A : B$  to indicate the order of the numbers: the number  $A$  is first and the number  $B$  is second.

Two ratios  $A : B$  and  $C : D$  are **equivalent ratios** if there is a nonzero number  $c$  such that  $C = cA$  and  $D = cB$ . For example, two ratios are equivalent if they both have values that are equal.

A ratio relationship between two types of quantities, such as 5 miles per 2 hours, can be described as a **rate** (i.e., the quantity 2.5 miles/hour).

The numerical part of the rate is called the **unit rate** and is simply the value of the ratio, in this case 2.5. This means that in 1 hour the car travels 2.5 miles. The **unit** for the rate is miles/hour, read miles per hour.

Guide students to complete the ratio column in the table as shown below.

#### Example 1: How Fast Is Our Class?

Record the results from the paper-passing exercise in the table below.

Trial	Number of Papers Passed	Time (in seconds)	Ratio of Number of Papers Passed to Time	Rate	Unit Rate
1	24	12	24 : 12, or 24 to 12, or equivalent ratio		
2	24	11	24 : 11, or 24 to 11, or equivalent ratio		
3	24	10	24 : 10, or 24 to 10, or equivalent ratio		
4	24	8	24 : 8, or 24 to 8, or equivalent ratio		

- When we started passing papers, the ratio of the number of papers to the number of seconds was 24 to 12, and by the end of the activity, the ratio of the number of papers to the number of seconds was 24 to 8. Are these two ratios equivalent? Explain why or why not.

Guide students in a discussion about the fact that the number of papers was constant, and the time decreased with each successive trial. See if students can relate this to rate and ultimately determine which rate is greatest.

- *The ratios are not equivalent since we passed the same number of papers in a shorter time. We passed 2 papers per second at the beginning and 3 papers per second by the end. Equivalent ratios must have the same value.*

The following questioning is meant to guide students into the realization that unit rate helps us to make comparisons between a variety of ratios and compare different data points.

- In another class period, students were able to pass 28 papers in 15 seconds, and then 28 papers in 12 seconds. A third class period passed 18 papers in 10 seconds. How do these compare to our class?

Use sample data here, or use real data collected from other classes prepared in advance.

- We could find how many papers were passed per second to make these comparisons. Answers on how they compare would vary depending on class results in the table.

Review the meaning of *rate* and *unit rate* in the Key Terms box, and complete the last two columns of the table, modeling how to find both rate and unit rate. The associated unit rate is the numerical value  $\frac{A}{B}$  when there are  $A$  units of one quantity for every  $B$  units of another quantity.

Trial	Number of Papers Passed	Time (in seconds)	Ratio of Number of Papers Passed to Time	Rate	Unit Rate
1	24	12	24 : 12, or 24 to 12, or equivalent ratio	2 papers per second	2
2	24	11	24 : 11, or 24 to 11, or equivalent ratio	Approximately 2.2 papers per second	2.2
3	24	10	24 : 10, or 24 to 10, or equivalent ratio	2.4 papers per second	2.4
4	24	8	24 : 8, or 24 to 8, or equivalent ratio	3 papers per second	3

### Example 2 (15 minutes): Our Class by Gender

Let's make a comparison of two quantities that are measured in the same units by comparing the ratio of the number of boys to the number of girls in this class to the ratio for different classes (and the whole grade). Sample discussion:

- In this class, we have 14 boys and 12 girls. In another class, there are 7 boys and 6 girls. *Note: Any class may be used for comparison; the ratios do not need to be equivalent.*

Guide students to complete the table accordingly, pausing to pose the questions below.

**Example 2: Our Class by Gender**

	Number of Boys	Number of Girls	Ratio of Boys to Girls
Class 1	14	12	7 to 6
Class 2	7	6	7 to 6
Whole 7 <sup>th</sup> Grade	Answers vary	Answers vary	

Create a pair of equivalent ratios by making a comparison of quantities discussed in this example.

- Are the ratios of boys to girls in the two classes equivalent?
- What could these ratios tell us?
- What does the ratio of the number of boys to the number of girls in Class 1 to the ratio of the number of boys to the number of girls in the entire seventh-grade class tell us?

This information is necessary to have in advance.

- Are they equivalent?
- If there is a larger ratio of boys to girls in one class than in the grade as a whole, what must be true about the boy-to-girl ratio in other classes? (It may be necessary to modify this question based upon real results or provide additional examples where this is true.)

Provide ratios from four classes and the total number of students in seventh grade. Using these provided ratios, challenge students to determine the ratio of Class 5 and derive a conclusion. (See detailed explanation in chart below.)

- *Sample solution: If the total number of students is 55 boys and 65 girls, or 120 students, then the missing number of boys for Class 5 is  $55 - 47 = 8$ , and the missing number of girls for Class 5 is  $65 - 49 = 16$ , resulting in a boy-to-girl ratio,  $8:16 = 1:2$ , that is smaller than the whole grade ratio.*

This extension also allows for students to see the usefulness of using the unit rate when making comparisons.

- How do we compare ratios when we have varying sizes of quantities?
  - *Finding the unit rate may help. In the data given here, the unit rate for both Classes 1 and 2 is approximately 1.16, and the unit rate for the whole grade is approximately 0.85. The unit rate for Class 4 is approximately 0.53, and the unit rate for Class 5 is 0.5.*

	Number of Boys	Number of Girls	Ratio of Boys to Girls
Class 1	14	12	7 to 6
Class 2	7	6	7 to 6
Class 3	16	12	8 to 6 or 4 to 3
Class 4	10	19	10 to 19
Class 5	? = 8	? = 16	1 to 2
Whole 7 <sup>th</sup> Grade	55	65	11 to 13

Larger than whole grade ratio

Smaller than whole grade ratio

The total number of students in the entire 7<sup>th</sup> grade is 120, which can be used to find the numbers for Class 5.

Review the Key Terms box focusing on the meaning of equivalent ratios, and give students 2 minutes to write down a pair of equivalent ratios comparing boys to girls or a similar comparison from their class. Discuss responses as a whole class.

**Exercise 1 (8 minutes): Which is the Better Buy?**

Read the problem as a class, and then allow time for students to solve independently. Ask students to share responses regarding how to determine if the ratios are equivalent. Reinforce key vocabulary from Grade 6.

**Exercise 1: Which is the Better Buy?**

Value-Mart is advertising a Back-to-School sale on pencils. A pack of 30 sells for \$7.97, whereas a 12-pack of the same brand costs \$4.77. Which is the better buy? How do you know?

*The better buy is the pack of 30. The pack of 30 has a smaller unit rate, approximately 0.27, as compared to the pack of 12 with a unit price of 0.40. You would pay \$0.27 per pencil in the pack of 30, whereas you would pay \$0.40 per pencil in the pack of 12.*

	<u>Pack of 30</u>	<u>Pack of 12</u>
<b>Relationship:</b>	\$7.97 for every 30 pencils \$15.94 for every 60 pencils	\$4.77 for every 12 pencils \$23.85 for every 60 pencils
<b>Ratio:</b>	7.97: 30; 15.94: 60	4.77: 12; 23.85: 60
<b>Rate:</b>	7.97/30, or approx. 0.27 dollars per pencil	4.77/12, or approx. 0.40 dollars per pencil
<b>Unit Rate:</b>	0.27	0.40
<b>Unit of Measure:</b>	dollars per pencil	dollars per pencil

Students may instead choose to compare the costs for every 60 pencils or every 360 pencils, etc. Facilitate a discussion of the different methods students may have used to arrive at their decisions.

**Closing (2 minutes)**

- How is finding an associated rate or unit rate helpful when making comparisons between quantities?
  - *The unit rate tells the number of units of one quantity per one unit of a second quantity. For example, a unit price of 0.4 means 1 juice box from a six-pack costs \$0.40.*

**Lesson Summary**

Unit rate is often a useful means for comparing ratios and their associated rates when measured in different units. The unit rate allows us to compare varying sizes of quantities by examining the number of units of one quantity per one unit of the second quantity. This value of the ratio is the unit rate.

**Exit Ticket (5 minutes)**

[http://www.youtube.com/watch?feature=player\\_embedded&v=tCKstDXMslQ](http://www.youtube.com/watch?feature=player_embedded&v=tCKstDXMslQ)

Students may need to see the video more than once. After watching the video the first time, it might be helpful for students to know that 100 meters is just a little longer than a football field (which measures 100 yards), and this record was recorded in 2009. Tillman the English bulldog covered a 100-meter stretch of a parking lot in a time of 19.678 seconds during the X Games XV in Los Angeles, California.



## Exit Ticket Sample Solutions

Watch the video clip of Tillman the English bulldog, the Guinness World Record holder for Fastest Dog on a Skateboard.

1. At the conclusion of the video, your classmate takes out his or her calculator and says, "Wow that was amazing! That means the dog went about 5 meters in 1 second!" Is your classmate correct, and how do you know?

*Yes, the classmate is correct. The dog traveled at an average rate of 100 meters in 19.678 seconds, or an associated rate of  $\frac{100}{19.678}$  meters per second, giving a unit rate of approximately 5.08.*

2. After seeing this video, another dog owner trained his dog, Lightning, to try to break Tillman's skateboarding record. Lightning's fastest recorded time was on a 75-meter stretch where it took him 15.5 seconds. Based on these data, did Lightning break Tillman's record for fastest dog? Explain how you know.

*No, Lightning did not break Tillman's record. Tillman traveled at an average rate of 5.08 meters per second (calculated from an associated rate of  $\frac{75}{15.5}$  meters per second), and Lightning traveled at an average rate of 4.84 meters per second (about  $\frac{1}{4}$  of a meter slower per second), making Tillman the faster skateboarder.*

## Problem Set Sample Solutions

1. Find each rate and unit rate.

- a. 420 miles in 7 hours

*Rate: 60 miles per hour; Unit Rate: 60*

- b. 360 customers in 30 days

*Rate: 12 customers per day; Unit Rate: 12*

- c. 40 meters in 16 seconds

*Rate:  $\frac{40}{16}$ , or 2.5 meters per second; Unit Rate: 2.5*

- d. \$7.96 for 5 pounds

*Rate:  $\frac{7.96}{5}$ , or approximately 1.59 dollars per pound; Unit Rate: 1.592*

2. Write three ratios that are equivalent to the one given: The ratio of right-handed students to left-handed students is 18:4.

*Sample response: The ratio of right-handed students to left-handed students is 9:2. The ratio of right-handed students to left-handed students is 36:8. The ratio of right-handed students to left-handed students is 27:6.*

3. Mr. Rowley has 16 homework papers and 14 exit tickets to return. Ms. Rivera has 64 homework papers and 60 exit tickets to return. For each teacher, write a ratio to represent the number of homework papers to number of exit tickets they have to return. Are the ratios equivalent? Explain.

*Mr. Rowley's ratio of homework papers to exit tickets is 16:14. Ms. Rivera's ratio of homework papers to exit tickets is 64:60. The ratios are not equivalent because Mr. Rowley's unit rate is  $\frac{8}{7}$ , or approximately 1.14, and Ms. Rivera's unit rate is  $\frac{16}{15}$ , or approximately 1.07.*

4. Jonathan's parents told him that for every 5 hours of homework or reading he completes, he would be able to play 3 hours of video games. His friend Lucas's parents told their son that he could play 30 minutes for every hour of homework or reading time he completes. If both boys spend the same amount of time on homework and reading this week, which boy gets more time playing video games? How do you know?

*If both boys spend 5 hours on homework and reading, Jonathan will be able to play 3 hours of video games, and Lucas will be able to play 2.5 hours of video games. Jonathan gets more time playing video games. Jonathan gets 0.6 hours (36 minutes) for every 1 hour of homework and reading time, whereas Lucas gets only 30 minutes for every 1 hour of homework or reading time.*

5. Of the 30 girls who tried out for the lacrosse team at Euclid Middle School, 12 were selected. Of the 40 boys who tried out, 16 were selected. Are the ratios of the number of students on the team to the number of students trying out the same for both boys and girls? How do you know?

*Yes, the ratios are the same: girls—12 to 30 or 2 to 5; boys—16 to 40 or 2 to 5. The value of each ratio is  $\frac{2}{5}$ .*

6. Devon is trying to find the unit price on a 6-pack of drinks on sale for \$2.99. His sister says that at that price, each drink would cost just over \$2.00. Is she correct, and how do you know? If she is not, how would Devon's sister find the correct price?

*Devon's sister is not correct. She divided the number of drinks by the cost, and to correctly find the unit price, she needs to divide the price by the number of drinks.  $\frac{2.99}{6}$ , or approximately 0.50, is the correct unit price. The cost is approximately 0.50 dollars per drink.*

7. Each year Lizzie's school purchases student agenda books, which are sold in the school store. This year, the school purchased 350 books at a cost of \$1,137.50. If the school would like to make a profit of \$1,500 to help pay for field trips and school activities, what is the least amount they can charge for each agenda book? Explain how you found your answer.

*The unit price per book the school paid is 3.25. To make \$1,500, you would need to make a profit of  $1500 \div 350 = 4.29$  per book.  $3.25 + 4.29$  is the cost per book or \$7.54.  $7.54 \cdot 350$  generates a revenue of \$2,639, and \$2,639 minus the initial cost of the books, \$1,137.50 (expense), gives \$1,501.50 of profit.*





## Lesson 2: Proportional Relationships

### Student Outcomes

- Students understand that two quantities are *proportional to* each other when there exists a constant (number) such that each measure in the first quantity multiplied by this constant gives the corresponding measure in the second quantity.
- When students identify the measures in the first quantity with  $x$  and the measures in the second quantity with  $y$ , they recognize that the second quantity is *proportional to* the first quantity if  $y = kx$  for some positive number  $k$ . They apply this same relationship when using variable choices other than  $x$  and  $y$ .

### Classwork

#### Example 1 (10 minutes): Pay by the Ounce Frozen Yogurt

The purpose of this example is for students to understand when measures of one quantity are proportional to measures of another quantity.

##### Example 1: Pay by the Ounce Frozen Yogurt

A new self-serve frozen yogurt store opened this summer that sells its yogurt at a price based upon the total weight of the yogurt and its toppings in a dish. Each member of Isabelle’s family weighed his dish, and this is what they found. Determine if the cost is proportional to the weight.

Weight (ounces)	12.5	10	5	8
Cost (\$)	5	4	2	3.20

The cost \_\_\_\_\_ the weight.

Discuss the following questions:

- Does everyone pay the same cost per ounce? How do you know?
  - Yes, it costs \$0.40 per ounce. If we divide each cost value by its corresponding weight, it will give the same unit price (or unit rate) of 0.40. Since we want to compare cost per ounce, we can use the unit (cost per ounce) to determine that we want to divide each cost value by each corresponding weight value.
- Isabelle’s brother takes an extra-long time to create his dish. When he puts it on the scale, it weighs 15 ounces. If everyone pays the same rate in this store, how much will his dish cost? How did you calculate this cost?
  - \$6. I determined the cost by multiplying 0.40 by 15 ounces.
- Since this is true, we say “the cost is proportional to the weight.” Complete the statement in your materials.

- What happens if you don't serve yourself any yogurt or toppings? How much do you pay?
  - \$0.
- Does the relationship above still hold true? In other words, if you buy 0 ounces of yogurt, then multiply by the cost per ounce, do you get 0?
  - *Even for 0, you can still multiply by this constant value to get the cost (not that you would do this, but we can examine this situation for the sake of developing a rule that is always true).*
- Always multiply the number of ounces,  $x$ , by the constant that represents cost per ounce to get the total cost,  $y$ . Pause with students to note that any variables could be chosen but that for the sake of this discussion, they are  $x$  and  $y$ .

The teacher should label the table with the indicated variables and guide students to do the same.

- For any measure  $x$ , how do we find  $y$ ?
  - *Multiply it by 0.40 (unit price).*
- Indicate this on the given chart, as done below. Be sure students do the same.

$x$ , Weight (ounces)	12.5	10	5	8
$y$ , Cost (\$)	5	4	2	3.20

*Note: Blue curved arrows in the original image point from each  $x$  value to its corresponding  $y$  value, with a small  $\cdot 0.40$  next to the arrow.*

- So,  $y = 0.40x$ .

### Example 2 (5 minutes): A Cooking Cheat Sheet

#### Example 2: A Cooking Cheat Sheet

In the back of a recipe book, a diagram provides easy conversions to use while cooking.

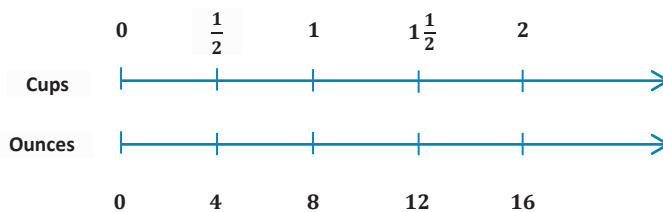

The ounces \_\_\_\_\_ the cups.

- What does the diagram tell us?
  - *The number of ounces in a given number of cups. More specifically, each pair of numbers indicates the correct matching of ounces to cups.*
- Is the number of ounces proportional to the number of cups? How do you know?
  - *Yes, you can multiply each number of cups by 8 to get the number of ounces.*

Have students complete the statement on their materials, *ounces is proportional to cups*, and note how they can tell. It is important to acknowledge that they could also divide by 8 if they know the number of ounces and are trying to find the number of cups. This discussion should lead to the importance of defining the quantities clearly.

- How many ounces are there in 4 cups? 5 cups? 8 cups? How do you know?
  - 32, 40, 64; each time, the number of cups is multiplied by 8 to get the number of ounces.
- For the sake of this discussion (and to provide continuity between examples), let's represent the cups with  $x$ , and the ounces with  $y$ .

The teacher should label the diagram with the indicated variables and guide students to do the same.

- For any number of cups  $x$ , how do we find the number of ounces,  $y$ ?
  - Multiply  $x$  by 8.
- So,  $y = 8x$ .
- If we want to verify that our equation is  $y = 8x$ , which  $x$  and  $y$  values can we use to see if it is true? How do you know?
  - We can choose any pair of given  $(x, y)$  values since the equation should model the relationship for every pair of values.

It is a good idea to check more than one pair. Guide students to substitute the pairs of values into the equation to prove that for each one, the equation is true.



### Exercise 1 (5 minutes)

Have students complete the following example independently, and then discuss responses as a class.

**Exercise 1**

During Jose's physical education class today, students visited activity stations. Next to each station was a chart depicting how many calories (on average) would be burned by completing the activity.

**Calories Burned While Jumping Rope**

	0	1	2	3	4
Time					
Calories Burned					
	0	11	22	33	44

a. Is the number of calories burned proportional to time? How do you know?  
*Yes, the time is always multiplied by the same number, 11, to find the calories burned.*

b. If Jose jumped rope for 6.5 minutes, how many calories would he expect to burn?  
*Jose would expect to burn 71.5 calories since 6.5 times 11 is 71.5.*

**Example 3 (15 minutes): Summer Job**

Read through Example 3 aloud. Allow for brief discussion (2 minutes) of summer jobs or ways students may have earned money over the summer. Pose the following questions:

- How much do you think Alex had earned by the end of 2 weeks?
  - *He probably earned twice what he had earned in week 1.*
- How will a table help us to check Alex's prediction?
  - *It will help us to see how his earnings grow over time and whether he will have enough money by the end of the summer. A table may also help to check calculations for reasonableness.*
- Where did the two given pairs of data come from?
  - *He earned \$112 after working 4 weeks; therefore, his rate was \$28 for every 1 week, or the total earnings is 28 times the week number.*
- Is this reasonable?
  - *Yes. You could include a brief discussion of minimum wage for part-time workers or babysitting rates so that students have some sense of reasonable earning amounts.*
- What other pair could we complete fairly easily?
  - *At 0 weeks, he has earned \$0.*
- If he makes the same amount of money each week, how will we find out his earnings after 2 weeks? 3 weeks?
  - *Since the rate will be the same, we could multiply each number of weeks by 28 to get the corresponding total earnings.*

Allow students time (3 minutes) to answer part (a) and complete the remaining values, if needed. Give students time to share responses to part (a).

**Example 3: Summer Job**

Alex spent the summer helping out at his family's business. He was hoping to earn enough money to buy a new \$220 gaming system by the end of the summer. Halfway through the summer, after working for 4 weeks, he had earned \$112. Alex wonders, "If I continue to work and earn money at this rate, will I have enough money to buy the gaming system by the end of the summer?"

To determine if he will earn enough money, he decided to make a table. He entered his total money earned at the end of Week 1 and his total money earned at the end of Week 4.

Week	0	1	2	3	4	5	6	7	8
Total Earnings		\$28			\$112				

- a. Work with a partner to answer Alex's question.

*Yes, Alex will have earned enough money to buy the \$220 gaming system by the end of the summer because he will have earned  $8 \cdot 28$ , or 224 dollars, for the 8 weeks he worked. A sample table is shown below.*

Week	0	1	2	3	4	5	6	7	8
Total Earnings	\$0	\$28	\$56	\$84	\$112	\$140	\$168	\$196	\$224

Allow for students to share responses with the class for part (b), and then record in their student pages.

- b. Are Alex's total earnings proportional to the number of weeks he worked? How do you know?

*Alex's total earnings are proportional to the number of weeks he worked. There exists a constant value, 28, which can be multiplied by the number of weeks to determine the corresponding earnings for that week. The table shows an example of a proportional relationship.*

### Closing (2 minutes)

- How do we know if two quantities are proportional to each other?
  - *Two quantities are proportional to each other if there is one constant number that is multiplied by each measure in the first quantity to give the corresponding measure in the second quantity.*
- How can we recognize a proportional relationship when looking at a table or a set of ratios?
  - *If each of the measures in the second quantity is divided by its corresponding measure in the first quantity and it produces the same number, called a constant, then the two quantities are proportional to each other.*

#### Lesson Summary

Measures of one type of quantity are *proportional to* measures of a second type of quantity if there is a number  $k$  so that for every measure  $x$  of a quantity of the first type, the corresponding measure  $y$  of a quantity of the second type is given by  $kx$ ; that is,  $y = kx$ . The number  $k$  is called the *constant of proportionality*.

A *proportional relationship* is a correspondence between two types of quantities such that the measures of quantities of the first type are proportional to the measures of quantities of the second type.

Note that proportional relationships and ratio relationships describe the same set of ordered pairs but in two different ways. Ratio relationships are used in the context of working with equivalent ratios, while proportional relationships are used in the context of rates.

In the example given below, the distance is *proportional to* time since each measure of distance,  $y$ , can be calculated by multiplying each corresponding time,  $t$ , by the same value, 10. This table illustrates a *proportional relationship* between time,  $t$ , and distance,  $y$ .

Time (h), $t$	0	1	2	3
Distance (km), $y$	0	10	20	30

### Exit Ticket (8 minutes)

Name \_\_\_\_\_

Date \_\_\_\_\_

## Lesson 2: Proportional Relationships

### Exit Ticket

Ms. Albero decided to make juice to serve along with the pizza at the Student Government party. The directions said to mix 2 scoops of powdered drink mix with a half gallon of water to make each pitcher of juice. One of Ms. Albero's students said she will mix 8 scoops with 2 gallons of water to make 4 pitchers. How can you use the concept of proportional relationships to decide whether the student is correct?

## Exit Ticket Sample Solutions

Ms. Albero decided to make juice to serve along with the pizza at the Student Government party. The directions said to mix 2 scoops of powdered drink mix with a half gallon of water to make each pitcher of juice. One of Ms. Albero's students said she will mix 8 scoops with 2 gallons of water to make 4 pitchers. How can you use the concept of proportional relationships to decide whether the student is correct?

Amount of Powdered Drink Mix (scoops)	1	2	4	8
Amount of Water (gallons)	$\frac{1}{4}$	$\frac{1}{2}$	1	2

As long as the amount of water is proportional to the number of scoops of drink mix, then the second quantity, amount of water, can be determined by multiplying the first quantity by the same constant. In this case, if the amount of powdered drink mix is represented by  $x$ , and the gallons of water are represented by  $y$ , then  $y = \frac{1}{4}x$ . To determine any of the measures of water, you will multiply the number of scoops by  $\frac{1}{4}$ .

## Problem Set Sample Solutions

1. A cran-apple juice blend is mixed in a ratio of cranberry to apple of 3 to 5.
- a. Complete the table to show different amounts that are proportional.

Amount of Cranberry	3	6	9
Amount of Apple	5	10	15

- b. Why are these quantities proportional?

The amount of apple is proportional to the amount of cranberry since there exists a constant number,  $\frac{5}{3}$ , that when multiplied by any of the given measures for the amount of cranberry always produces the corresponding amount of apple. If the amount of cranberry is represented by  $x$ , and the amount of apple is represented by  $y$ , then each pair of quantities satisfies the equation  $y = \frac{5}{3}x$ . A similar true relationship could be derived by comparing the amount of cranberry to the amount of apple. In the case where  $x$  is the amount of apple and  $y$  is the amount of cranberry, the equation would be  $y = \frac{3}{5}x$ .

2. John is filling a bathtub that is 18 inches deep. He notices that it takes two minutes to fill the tub with three inches of water. He estimates it will take 10 more minutes for the water to reach the top of the tub if it continues at the same rate. Is he correct? Explain.

Yes. In 10 more minutes, the tub will reach 18 inches. At that time, the ratio of time to height may be expressed as 12 to 18, which is equivalent to 2 to 3. The height of the water in the bathtub increases  $1\frac{1}{2}$  inches every minute.

Time (minutes)	1	2	12
Bathtub Water Height (inches)	$1\frac{1}{2}$	3	18



## Lesson 3: Identifying Proportional and Non-Proportional Relationships in Tables

### Student Outcomes

- Students examine situations to decide whether two quantities are proportional to each other by checking for a constant multiple between measures of  $x$  and measures of  $y$  when given in a table.
- Students study examples of relationships that are not proportional in addition to those that are.

### Classwork

#### Example (8 minutes)

##### Example

You have been hired by your neighbors to babysit their children on Friday night. You are paid \$8 per hour. Complete the table relating your pay to the number of hours you worked.

Hours Worked	Pay (in dollars)
1	8
2	16
3	24
4	32
$4\frac{1}{2}$	36
5	40
6	48
6.5	52

##### Scaffolding:

Challenge advanced learners with the following question:

- If the hours change, does that mean the total pay must change?
- Yes, as hours increase, the pay increases.

Based on the table above, is the pay proportional to the hours worked? How do you know?

*Yes, the pay is proportional to the hours worked because every ratio of the amount of pay to the number of hours worked is the same. The ratio is 8:1, and every measure of hours worked multiplied by 8 will result in the corresponding measure of pay.*

$$\frac{8}{1} = 8 \quad \frac{16}{2} = 8 \quad \frac{24}{3} = 8 \quad \frac{32}{4} = 8 \quad \frac{36}{4.5} = 8 \quad \frac{40}{5} = 8 \quad \frac{48}{6} = 8 \quad \frac{52}{6.5} = 8$$



Discuss the following questions:

- Explain how you completed the table.
- How did you determine the pay for  $4\frac{1}{2}$  hours?
  - *Multiply the hours by the constant multiple of 8 that relates hours to pay. Four hours times 8 will result in a pay of 32 dollars. Multiplying the extra half hour times 8 will result in an additional 4 dollars.  $\$32 + \$4 = \$36$ .*
- How could you use the information to determine the pay for a week in which you worked 20 hours?
  - *Multiply 20 hours by 8 dollars per hour or continue to extend the table.*
- How many other ways can the answer be determined?
  - *You could have taken the amount of money made for working 4 hours and multiplied it by 5.*
- If the quantities in the table were graphed, would the point  $(0, 0)$  be on that graph? What would it mean in the context of the problem?
  - *Yes, the point  $(0, 0)$  could be a point in the table because if you multiply 0 by any constant, you would get 0. For this problem, the point  $(0, 0)$  represents working 0 hours and earning \$0.*
- Describe the relationship between the amount of money earned and the number of hours worked in this example.
  - *The two quantities are in a proportional relationship. A proportional relationship exists because when every measure of time is multiplied by the same number, the corresponding measures of pay are obtained.*
- How can multiplication and division be used to show the earnings are proportional to the number of hours worked?
  - *Every measure of time (hours) can be multiplied by the constant 8 to determine each measure of pay. Division can be used by dividing each measure of  $y$  (pay) by 8 to get the corresponding  $x$  (hours) measure.*

Guide students to write a response to the question in the student materials.

- In this example, is the amount of pay proportional to the number of hours worked? How do you know?
  - *Yes, the amount of money is proportional to the number of hours worked because there is a number, 8, such that each measure of the first quantity multiplied by this same number, 8, gives the corresponding measure of the second quantity.*

## Exercises 1–4 (15 minutes)

## Exercises

For Exercises 1–3, determine if  $y$  is proportional to  $x$ . Justify your answer.

1. The table below represents the relationship of the amount of snowfall (in inches) in 5 counties to the amount of time (in hours) of a recent winter storm.

$x$ Time (h)	$y$ Snowfall (in.)
2	10
6	12
8	16
2.5	5
7	14

$$\frac{10}{2} = 5 \quad \frac{12}{6} = 2 \quad \frac{16}{8} = 2 \quad \frac{5}{2.5} = 2 \quad \frac{14}{7} = 2$$

$y$  (snowfall) is not proportional to  $x$  (time) because all of the values of the ratios comparing snowfall to time are not equivalent. All of the values of the ratios must be the same for the relationships to be proportional. There is NOT one number such that each measure of  $x$  (time) multiplied by the number gives the corresponding measure of  $y$  (snowfall).

2. The table below shows the relationship between the cost of renting a movie (in dollars) to the number of days the movie is rented.

$x$ Number of Days	$y$ Cost (dollars)
6	2
9	3
24	8
3	1

$$\frac{2}{6} = \frac{1}{3} \quad \frac{3}{9} = \frac{1}{3} \quad \frac{8}{24} = \frac{1}{3} \quad \frac{1}{3} = \frac{1}{3}$$

$y$  (cost) is proportional to  $x$  (number of days) because all of the values of the ratios comparing cost to days are equivalent. All of the values of the ratios are equal to  $\frac{1}{3}$ . Therefore, every measure of  $x$  (days) can be multiplied by the number  $\frac{1}{3}$  to get each corresponding measure of  $y$  (cost).

3. The table below shows the relationship between the amount of candy bought (in pounds) and the total cost of the candy (in dollars).

$x$ Amount of Candy (pounds)	$y$ Cost (dollars)
5	10
4	8
6	12
8	16
10	20

$$\frac{10}{5} = 2 \quad \frac{8}{4} = 2 \quad \frac{12}{6} = 2 \quad \frac{16}{8} = 2 \quad \frac{20}{10} = 2$$

$y$  (cost) is proportional to  $x$  (amount of candy) because all of the values of the ratios comparing cost to pounds are equivalent. All of the values of the ratios are equal to 2. Therefore, every measure of  $x$  (amount of candy) can be multiplied by the number 2 to get each corresponding measure of  $y$  (cost).

Possible questions asked by the teacher or students:

- When looking at ratios that describe two quantities that are proportional in the same order, do the ratios always have to be equivalent?
  - Yes, all the ratios are equivalent, and a constant exists that can be multiplied by the measure of the first quantity to get the measure of the second quantity for every ratio pair.

- For each example, if the quantities in the table were graphed, would the point (0,0) be on that graph? Describe what the point (0,0) would represent in each table.
  - *Exercise 1: 0 inches of snowfall in 0 hours*
  - *Exercise 2: Renting a movie for 0 days costs \$0*
  - *Exercise 3: 0 pounds of candy costs \$0*
- Do the  $x$ - and  $y$ -values need to go up at a constant rate? In other words, when the  $x$ - and  $y$ -values both go up at a constant rate, does this always indicate that the relationship is proportional?
  - *Yes, the relationship is proportional if a constant exists such that each measure of the  $x$  when multiplied by the constant gives the corresponding  $y$ -value.*

4. Randy is driving from New Jersey to Florida. Every time Randy stops for gas, he records the distance he traveled in miles and the total number of gallons he used.
- Assume that the number of miles driven is proportional to the number of gallons consumed in order to complete the table.

Gallons Consumed	2	4	7	8	10	12
Miles Driven	54	108	189	216	270	324

*Since the quantities are proportional, then every ratio comparing miles driven to gallons consumed must be equal. Using the given values for each quantity, the value of the ratio is*

$$\frac{54}{2} = 27$$

$$\frac{216}{8} = 27$$

*If the number of gallons consumed is given and the number of miles driven is the unknown, then multiply the number of gallons consumed by 27 to determine the number of miles driven.*

$$4(27) = 108$$

$$10(27) = 270$$

$$12(27) = 324$$

*If the number of miles driven is given and the number of gallons consumed is the unknown, then divide the number of miles driven by 27 to determine the number of gallons consumed.*

$$\frac{189}{27} = 7$$

- Why is it important for you to know that the number of miles are proportional to the number of gallons used?
  - *Without knowing this proportional relationship exists, just knowing how many gallons you consumed will not allow you to determine how many miles you traveled. You would not know if the same relationship exists for each pair of numbers.*
- Describe the approach you used to complete the table.
  - *Since the number of miles driven is proportional to the number of gallons consumed, a constant exists such that every measure of gallons used can be multiplied by the constant to give the corresponding amount of miles driven. Once this constant is found to be 27, it can be used to fill in the missing parts by multiplying each number of gallons by 27.*

- What is the value of the constant? Explain how the constant was determined.
  - *The value of the constant is 27. This was determined by dividing the given number of miles driven by the given number of gallons consumed.*
- Explain how to use multiplication and division to complete the table.
  - *If the number of gallons consumed was given, then that number is to be multiplied by the constant of 27 to determine the amount of the miles driven. If the number of miles driven were given, then that number needs to be divided by the constant of 27 to determine the number of gallons consumed.*

### Exercise 5 (15 minutes)

Have students work with a partner. Give each pair two  $3 \times 5$  index cards. On one index card, the students work together to create a table of two quantities that are proportional to one another. On the other index card, the students create a story problem that would generate the table. Once complete, the teacher collects all the table cards and all the story cards. The teacher displays the table cards around the room and randomly passes out story cards. Students are to match the stories to the correct table representations.

### Closing (2 minutes)

- How can you use a table to determine whether the relationship between two quantities is proportional?
  - *The quantities are proportional if a constant number exists such that each measure in the first quantity multiplied by this constant gives the corresponding measure in the second quantity.*

#### Lesson Summary

A type of quantity is proportional to a second if there is a constant number such that the product of each measure of the first type and the constant is equal to the corresponding measure of the second type.

Steps to determine if quantities in a table are proportional to each other:

1. For each row (or column), calculate  $\frac{B}{A}$ , where  $A$  is the measure of the first quantity and  $B$  is the measure of the second quantity.
2. If the value of  $\frac{B}{A}$  is the same for each pair of numbers, then the quantities in the table are proportional to each other.

### Exit Ticket (5 minutes)

Name \_\_\_\_\_

Date \_\_\_\_\_

## Lesson 3: Identifying Proportional and Non-Proportional Relationships in Tables

### Exit Ticket

The table below shows the price, in dollars, for the number of roses indicated.

<b>Number of Roses</b>	3	6	9	12	15
<b>Price (Dollars)</b>	9	18	27	36	45

1. Is the price proportional to the number of roses? How do you know?

2. Find the cost of purchasing 30 roses.

## Exit Ticket Sample Solutions

The table below shows the price, in dollars, for the number of roses indicated.

Number of Roses	3	6	9	12	15
Price (Dollars)	9	18	27	36	45

1. Is the price proportional to the number of roses? How do you know?

*The quantities are proportional to one another because there is a constant of 3 such that when the number of roses is multiplied by the constant, the result is the corresponding price.*

2. Find the cost of purchasing 30 roses.

*If there are 30 roses, then the cost would be  $30 \times 3 = \$90$ .*

## Problem Set Sample Solutions

In each table, determine if  $y$  is proportional to  $x$ . Explain why or why not.

1.

$x$	$y$
3	12
5	20
2	8
8	32

2.

$x$	$y$
3	15
4	17
5	19
6	21

3.

$x$	$y$
6	4
9	6
12	8
3	2

1. *Yes,  $y$  is proportional to  $x$  because the values of all ratios of  $\frac{y}{x}$  are equivalent to 4. Each measure of  $x$  multiplied by this constant of 4 gives the corresponding measure in  $y$ .*
2. *No,  $y$  is not proportional to  $x$  because the values of all the ratios of  $\frac{y}{x}$  are not equivalent. There is not a constant where every measure of  $x$  multiplied by the constant gives the corresponding measure in  $y$ . The values of the ratios are 5, 4, 25, 3, 8, and 3.5.*
3. *Yes,  $y$  is proportional to  $x$  because a constant value of  $\frac{2}{3}$  exists where each measure of  $x$  multiplied by this constant gives the corresponding measure in  $y$ .*
4. Kayla made observations about the selling price of a new brand of coffee that sold in three different-sized bags. She recorded those observations in the following table:

Ounces of Coffee	6	8	16
Price in Dollars	\$2.10	\$2.80	\$5.60

- a. Is the price proportional to the amount of coffee? Why or why not?

*Yes, the price is proportional to the amount of coffee because a constant value of 0.35 exists where each measure of  $x$  multiplied by this constant gives the corresponding measure in  $y$ .*

- b. Use the relationship to predict the cost of a 20 oz. bag of coffee.

*20 ounces will cost \$7.*

5. You and your friends go to the movies. The cost of admission is \$9.50 per person. Create a table showing the relationship between the number of people going to the movies and the total cost of admission.

Explain why the cost of admission is proportional to the amount of people.

Number of People	Cost (dollars)
1	9.50
2	19
3	28.50
4	38

*The cost is proportional to the number of people because a constant value of 9.50 exists where each measure of the number of people multiplied by this constant gives the corresponding measure in  $y$ .*

6. For every 5 pages Gil can read, his daughter can read 3 pages. Let  $g$  represent the number of pages Gil reads, and let  $d$  represent the number of pages his daughter reads. Create a table showing the relationship between the number of pages Gil reads and the number of pages his daughter reads.

Is the number of pages Gil's daughter reads proportional to the number of pages he reads? Explain why or why not.

$g$	$d$
5	3
10	6
15	9

*Yes, the number of pages Gil's daughter reads is proportional to the number of pages Gil reads because all the values of the ratios are equivalent to 0.6. When I divide the number of pages Gil's daughter reads by the number of pages Gil reads, I always get the same quotient. Therefore, every measure of the number of pages Gil reads multiplied by the constant 0.6 gives the corresponding values of the number of pages Gil's daughter's reads.*

7. The table shows the relationship between the number of parents in a household and the number of children in the same household. Is the number of children proportional to the number of parents in the household? Explain why or why not.

Number of Parents	Number of Children
0	0
1	3
1	5
2	4
2	1

*No, there is not a proportional relationship because there is no constant such that every measure of the number of parents multiplied by the constant would result in the corresponding values of the number of children. When I divide the number of children by the corresponding number of parents, I do not get the same quotient every time. Therefore, the values of the ratios of children to parents are not equivalent. They are 3, 5, 2, and 0.5.*

8. The table below shows the relationship between the number of cars sold and the amount of money earned by the car salesperson. Is the amount of money earned, in dollars, proportional to the number of cars sold? Explain why or why not.

Number of Cars Sold	Money Earned (in dollars)
1	250
2	600
3	950
4	1,076
5	1,555

*No, there is no constant such that every measure of the number of cars sold multiplied by the constant would result in the corresponding values of the earnings because the ratios of money earned to number of cars sold are not equivalent; the values of the ratios are 250, 300,  $316\frac{2}{3}$ , 269, and 311.*

9. Make your own example of a relationship between two quantities that is NOT proportional. Describe the situation, and create a table to model it. Explain why one quantity is not proportional to the other.

*Answers will vary but should include pairs of numbers that do not always have the same value  $\frac{B}{A}$ .*





## Lesson 4: Identifying Proportional and Non-Proportional Relationships in Tables

### Student Outcomes

- Students examine situations to decide whether two quantities are proportional to each other by checking for a constant multiple between measures of  $x$  and measures of  $y$  when given in a table or when required to create a table.
- Students study examples of relationships that are not proportional in addition to those that are.

### Classwork

#### Example (20 minutes): Which Team Will Win the Race?

Students will work on the following example independently for 10 minutes. Then, students may collaborate with a partner or small group of classmates to discuss answers for 5 minutes. During this time students are to compare, critique the work that was done individually, and work together to come up with a presentable solution. If all students completed the task individually, then they should check each other's work for accuracy and completeness. Lastly, students share their solutions with the class for 5 minutes. Many times there are multiple ways that the problem may have been completed or explained. Circulate during the collaboration time, and select students that utilized different approaches. If the same approach was used throughout, select different students for different parts of the problem to present.

#### Example: Which Team Will Win the Race?

You have decided to walk in a long-distance race. There are two teams that you can join. Team A walks at a constant rate of 2.5 miles per hour. Team B walks 4 miles the first hour and then 2 miles per hour after that.

**Task:** Create a table for each team showing the distances that would be walked for times of 1, 2, 3, 4, 5, and 6 hours. Using your tables, answer the questions that follow.

Team A	
Time (h)	Distance (miles)
1	2.5
2	5
3	7.5
4	10
5	12.5
6	15

Team B	
Time (h)	Distance (miles)
1	4
2	6
3	8
4	10
5	12
6	14

- a. For which team is distance proportional to time? Explain your reasoning.

*Distance is proportional to time for Team A since all the ratios comparing distance to time are equivalent. The value of each ratio is 2.5. Every measure of time can be multiplied by 2.5 to give the corresponding measures of distance.*

- b. Explain how you know the distance for the other team is not proportional to time.

*For Team B, the ratios are not equivalent. The values of the ratios are  $4$ ,  $3$ ,  $\frac{8}{3}$ ,  $\frac{5}{2}$ ,  $\frac{12}{5}$ , and  $\frac{7}{3}$ . Therefore, every measure of time cannot be multiplied by a constant to give each corresponding measure of distance.*

- c. At what distance in the race would it be better to be on Team B than Team A? Explain.

*If the race were fewer than 10 miles, Team B is faster because more distance would be covered in less time.*

- d. If the members on each team walked for 10 hours, how far would each member walk on each team?

*Team A = 25 miles*

*Team B = 22 miles*

- e. Will there always be a winning team, no matter what the length of the course? Why or why not?

*No, there would be a tie (both teams win) if the race were 10 miles long. It would take each team 4 hours to complete a 10-mile race.*

- f. If the race were 12 miles long, which team should you choose to be on if you wish to win? Why would you choose this team?

*I should choose Team A because they would finish in 4.8 hours compared to Team B finishing in 5 hours.*

- g. How much sooner would you finish on that team compared to the other team?

*$\frac{2}{10}$  of an hour or  $\frac{2}{10}(60) = 12$  minutes*

**Scaffolding:**

The teacher may be able to extend the concept to derive the formula  $d = rt$  followed by a class discussion on how to transform the formula where rate can be found in terms of distance and time. Also, time can be transformed in terms of distance and rate. Lastly, distance and time can be related to  $y$  and  $x$  variables.

**Exercises (10 minutes)**

1. Bella types at a constant rate of 42 words per minute. Is the number of words she can type proportional to the number of minutes she types? Create a table to determine the relationship.

Minutes	1	2	3	6	60
Number of Words	42	84	126	252	2520

*This relationship is proportional because I can multiply the number of minutes by the constant to get the corresponding number of words. The value of the ratio is 42. The constant is also 42.*

2. Mark recently moved to a new state. During the first month, he visited five state parks. Each month after, he visited two more. Complete the table below, and use the results to determine if the number of parks visited is proportional to the number of months.

Number of Months	Number of State Parks
1	5
2	7
3	9
10	23

*This relationship is not proportional. There is no constant value that can be multiplied by the number of months to get the corresponding number of parks visited.*

3. The table below shows the relationship between the side length of a square and the area. Complete the table. Then, determine if the length of the sides is proportional to the area.

Side Length (inches)	Area (square inches)
1	1
2	4
3	9
4	16
5	25
8	64
12	144

*This relationship is not proportional. There is no constant value that can be multiplied by the side length to get the corresponding area.*

### Closing (5 minutes)

- A student notices in the table below that as the  $x$ -value increases by 3, the  $y$ -value increases by 4. Because there is a pattern, the student has determined that  $x$  is proportional to  $y$ . Do you agree with the student's claim? Why or why not?

$x$	$y$
4	1
7	5
10	9
13	13
16	17

- *No, this table does not show that  $x$  is proportional to  $y$ . A pattern is not enough proof that a proportional relationship exists. There is no constant that could be multiplied by the  $x$ -value to get the corresponding  $y$ -value. Therefore, the table does not represent a proportion.*

### Exit Ticket (10 minutes)

Name \_\_\_\_\_

Date \_\_\_\_\_

## Lesson 4: Identifying Proportional and Non-Proportional Relationships in Tables

### Exit Ticket

The table below shows the relationship between the side lengths of a regular octagon and its perimeter.

Side Lengths, $s$ (inches)	Perimeter, $P$ (inches)
1	8
2	16
3	24
4	32
9	
12	

Complete the table.

If Gabby wants to make a regular octagon with a side length of 20 inches using wire, how much wire does she need? Justify your reasoning with an explanation of whether perimeter is proportional to the side length.

## Exit Ticket Sample Solutions

The table below shows the relationship between the side lengths of a regular octagon and its perimeter.

Side Lengths, $s$ (inches)	Perimeter, $P$ (inches)
1	8
2	16
3	24
4	32
9	72
12	96

Complete the table.

If Gabby wants to make a regular octagon with a side length of 20 inches using wire, how much wire does she need? Justify your reasoning with an explanation of whether perimeter is proportional to the side length.

$$20(8) = 160$$

*Gabby would need 160 inches of wire to make a regular octagon with a side length of 20 inches. This table shows that the perimeter is proportional to the side length because the constant is 8, and when all side lengths are multiplied by the constant, the corresponding perimeter is obtained. Since the perimeter is found by adding all 8 side lengths together (or multiplying the length of 1 side by 8), the two numbers must always be proportional.*

## Problem Set Sample Solutions

1. Joseph earns \$15 for every lawn he mows. Is the amount of money he earns proportional to the number of lawns he mows? Make a table to help you identify the type of relationship.

Number of Lawns Mowed	1	2	3	4
Earnings (\$)	15	30	45	60

*The table shows that the earnings are proportional to the number of lawns mowed. The value of each ratio is 15. The constant is 15.*

2. At the end of the summer, Caitlin had saved \$120 from her summer job. This was her initial deposit into a new savings account at the bank. As the school year starts, Caitlin is going to deposit another \$5 each week from her allowance. Is her account balance proportional to the number of weeks of deposits? Use the table below. Explain your reasoning.

Time (in weeks)	0	1	2	3
Account Balance (\$)	120	125	130	135

*Caitlin's account balance is not proportional to the number of weeks because there is no constant such that any time in weeks can be multiplied to get the corresponding balance. In addition, the ratio of the balance to the time in weeks is different for each column in the table.*

*120:0 is not the same as 125:1.*

3. Lucas and Brianna read three books each last month. The table shows the number of pages in each book and the length of time it took to read the entire book.

Pages Lucas Read	208	156	234
Time (hours)	8	6	9

Pages Brianna Read	168	120	348
Time (hours)	6	4	12

- a. Which of the tables, if any, represent a proportional relationship?

*The table shows Lucas's number of pages read to be proportional to the time because when the constant of 26 is multiplied by each measure of time, it gives the corresponding values for the number of pages read.*

- b. Both Lucas and Brianna had specific reading goals they needed to accomplish. What different strategies did each person employ in reaching those goals?

*Lucas read at a constant rate throughout the summer, 26 pages per hour, whereas Brianna's reading rate was not the same throughout the summer.*



## Lesson 5: Identifying Proportional and Non-Proportional Relationships in Graphs

### Student Outcomes

- Students decide whether two quantities are proportional to each other by graphing on a coordinate plane and observing whether the graph is a straight line through the origin.
- Students study examples of quantities that are proportional to each other as well as those that are not.

### Classwork

#### Opening Exercise (5 minutes)

Give students the ratio table, and ask them to identify if the two quantities are proportional to each other and to give reasoning for their answers.

#### Opening Exercise

Isaiah sold candy bars to help raise money for his scouting troop. The table shows the amount of candy he sold compared to the money he received.

$x$ Candy Bars Sold	$y$ Money Received (\$)
2	3
4	5
8	9
12	12

Is the amount of candy bars sold proportional to the money Isaiah received? How do you know?

*The two quantities are not proportional to each other because a constant describing the proportion does not exist.*

### Exploratory Challenge/Examples 1-3: From a Table to a Graph

#### Example 1 (9 minutes)

Prompt students to create another ratio table that contains two sets of quantities that are proportional to each other using the first ratio on the table.

Present a coordinate grid, and ask students to recall content from Grades 5 and 6 on the following: coordinate plane,  $x$ -axis,  $y$ -axis, origin, quadrants, plotting points, and ordered pairs.

As a class, ask students to express the ratio pairs as ordered pairs.

Questions to discuss:

- What is the origin, and where is it located?
  - The origin is the intersection of the  $x$ -axis and the  $y$ -axis, at the ordered pair  $(0, 0)$ .*

- Why are we going to focus on Quadrant 1?
  - *Since we are measuring or counting quantities (number of candy bars sold and amount of money), the numbers in our ratios will be positive. Both the  $x$ -coordinates and the  $y$ -coordinates are positive in Quadrant 1.*
- What should we label the  $x$ -axis and  $y$ -axis?
  - *The  $x$ -axis should be labeled as the number of candy bars sold, and the  $y$ -axis should be labeled as the amount of money received.*
- Could it be the other way around?
  - *No, the amount of money received depends on the number of candy bars being sold. The dependent variable should be labeled on the  $y$ -axis. Therefore, the amount of money should be labeled on the  $y$ -axis.*
- How should we note that on the table?
  - *The first value in each of the pairs is the  $x$ -coordinate (the independent variable), and the second value in each of the pairs is the  $y$ -coordinate (the dependent variable).*
- How do we plot the first ratio pair?
  - *If the relationship is 3: 2, where 3 represents 3 candy bars sold and 2 represents 2 dollars received, then from the origin, we move 3 units to the right on the  $x$ -axis and move up 2 units on the  $y$ -axis.*
- When we are plotting a point, where do we count from?
  - *The origin,  $(0, 0)$ .*

Have students plot the rest of the points and use a ruler to join the points.

- What observations can you make about the arrangement of the points?
  - *The points all fall on a line.*
- Do we extend the line in both directions? Explain why or why not.
  - *Technically, the line for this situation should start at  $(0, 0)$  to represent 0 dollars for 0 candy bars, and extend infinitely in the positive direction because the more candy bars Isaiah sells, the more money he makes.*
- Would all proportional relationships pass through the origin? Think back to those discussed in previous lessons.

Take a few minutes for students to share some of the context of previous examples and whether  $(0, 0)$  would always be included on the line that passes through the pairs of points in a proportional relationship.

- *Yes, it should always be included for proportional relationships. For example, if a worker works zero hours, then he or she would get paid zero dollars, or if a person drives zero minutes, the distance covered is zero miles.*
- What can you infer about graphs of two quantities that are proportional to each other?
  - *The points will appear to be on a line that goes through the origin.*
- Why do you think the points appear on a line?
  - *Each candy bar is being sold for \$1.50; therefore, 1.5 is the unit rate and also the constant of the proportion. This means that for every increase of 1 on the  $x$ -axis, there will be an increase of the same proportion (the constant, 1.5) on the  $y$ -axis. When the points are connected, a line is formed. Each point may not be part of the set of ratios; however, the line would pass through all of the points that do exist in the set of ratios.*



Complete “Important Note” as a class. *In a proportional relationship, the points will all appear on a line going through the origin.*

Exploratory Challenge/Examples 1-3: From a Table to a Graph

**Example 1**

Using the ratio provided, create a table that shows that money received is proportional to the number of candy bars sold. Plot the points in your table on the grid.

$x$ Candy Bars Sold	$y$ Money Received (\$)
2	3
4	6
6	9
8	12

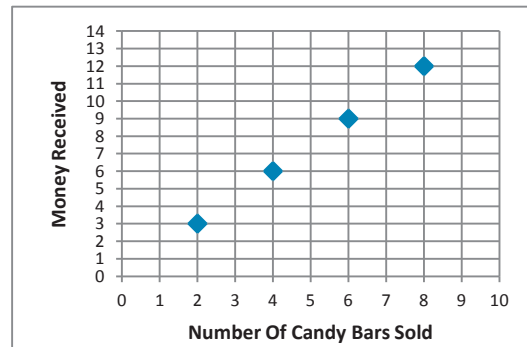

**Important Note:**

Characteristics of graphs of proportional relationships:

1. *Points appear on a line.*
2. *The line goes through the origin.*

**Example 2 (8 minutes)**

Have students plot ordered pairs for all the values of the Opening Exercise.

- Does the ratio table represent quantities that are proportional to each other?
  - *No, not all the quantities are proportional to each other.*
- What can you predict about the graph of this ratio table?
  - *The points will not appear on a line and will not go through the origin.*
- Was your prediction correct?
  - *My prediction was partly correct. The majority of the points appear on a line that goes through the origin.*
- From this example, what is important to note about graphs of two quantities that are not proportional to each other?
  - *The graph could go through the origin; but if it does not lie in a straight line, it does not represent two quantities that are proportional to each other.*

**Example 2**

Graph the points from the Opening Exercise.

$x$ Candy Bars Sold	$y$ Money Received (\$)
2	3
4	5
8	9
12	12

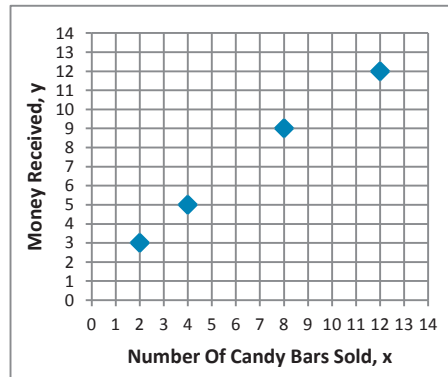
**Example 3 (8 minutes)**

Have students plot the points from Example 3.

- How are the graphs of the data in Examples 1 and 3 similar? How are they different?
  - *In both graphs, the points appear on a line. One graph is steeper than the other. The graph in Example 1 begins at the origin, but the graph in Example 3 does not.*
- What do you know about the ratios before you graph them?
  - *The quantities are not proportional to each other.*
- What can you predict about the graph of this ratio table?
  - *The points will not appear on a line that goes through the origin.*
- Was your prediction correct?
  - *No. The graph forms a line, but the line does not go through the origin.*
- What are the similarities of the graphs of two quantities that are proportional to each other and the graphs of two quantities that are not proportional?
  - *Both graphs can have points that appear on a line, but the graph of the quantities that are proportional to each other must also go through the origin.*

**Example 3**

Graph the points provided in the table below, and describe the similarities and differences when comparing your graph to the graph in Example 1.

$x$	$y$
0	6
3	9
6	12
9	15
12	18

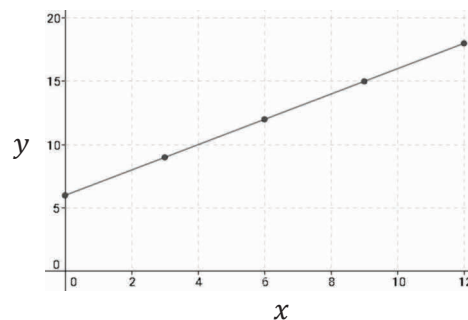

**Similarities with Example 1:**

*The points of both graphs fall in a line.*

**Differences from Example 1:**

*The points of the graph in Example 1 appear on a line that passes through the origin. The points of the graph in Example 3 appear on a line that does not pass through the origin.*

**Closing (5 minutes)**

- How are proportional quantities represented on a graph?
  - *They are represented on a graph where the points appear on a line that passes through the origin.*
- What is a common mistake that someone might make when deciding whether a graph of two quantities shows that they are proportional to each other?
  - *Both graphs can have points that appear on a line, but the graph of the quantities that are proportional to each other also goes through the origin. In addition, the graph could go through the origin, but the points do not appear on a line.*

**Lesson Summary**

**When a proportional relationship between two types of quantities is graphed on a coordinate plane, the plotted points lie on a line that passes through the origin.**

**Exit Ticket (10 minutes)**

Name \_\_\_\_\_

Date \_\_\_\_\_

## Lesson 5: Identifying Proportional and Non-Proportional Relationships in Graphs

### Relationships in Graphs

#### Exit Ticket

1. The following table gives the number of people picking strawberries in a field and the corresponding number of hours that those people worked picking strawberries. Graph the ordered pairs from the table. Does the graph represent two quantities that are proportional to each other? Explain why or why not.

$x$	$y$
1	3
7	1
4	2

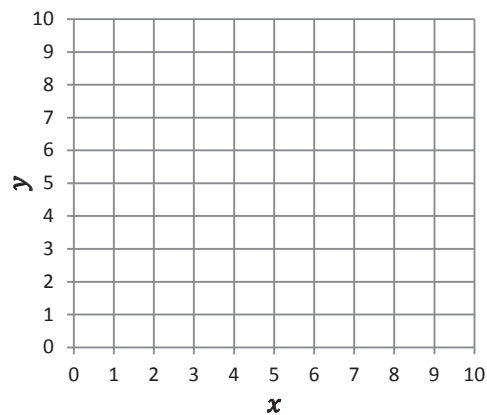

2. Use the given values to complete the table. Create quantities proportional to each other and graph them.

$x$	$y$
4	2

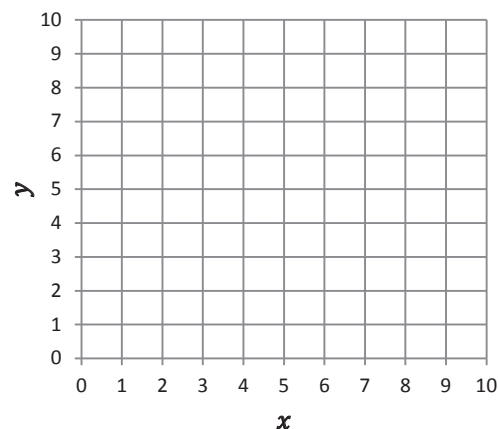



## Exit Ticket Sample Solutions

1. The following table gives the number of people picking strawberries in a field and the corresponding number of hours that those people worked picking strawberries. Graph the ordered pairs from the table. Does the graph represent two quantities that are proportional to each other? Why or why not?

*Although the points fall on a line, the line does not pass through the origin, so the graph does not represent two quantities that are proportional to each other.*

$x$	$y$
1	3
7	1
4	2

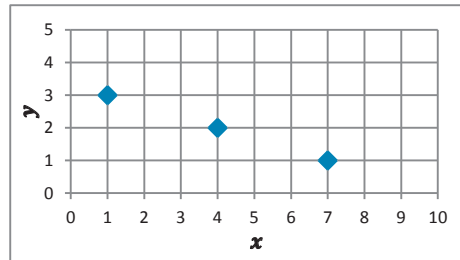

2. Use the given values to complete the table. Create quantities proportional to each other and graph.

$x$	$y$
2	1
4	2
6	3

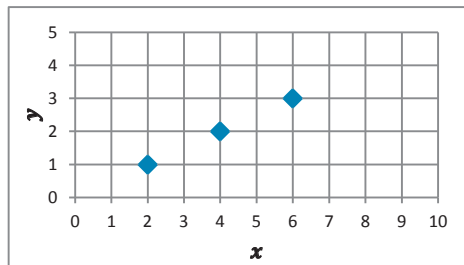

- 3.
- What are the differences between the graphs in Problems 1 and 2?  
*The graph in Problem 1 forms a line that slopes downward, while the graph in Problem 2 slopes upward.*
  - What are the similarities in the graphs in Problems 1 and 2?  
*Both graphs form lines, and both graphs include the point (4, 2).*
  - What makes one graph represent quantities that are proportional to each other and one graph not represent quantities that are proportional to each other in Problems 1 and 2?  
*Although both graphs form lines, the graph that represents quantities that are proportional to each other needs to pass through the origin.*

## Problem Set Sample Solutions

1. Determine whether or not the following graphs represent two quantities that are proportional to each other. Explain your reasoning.

a.

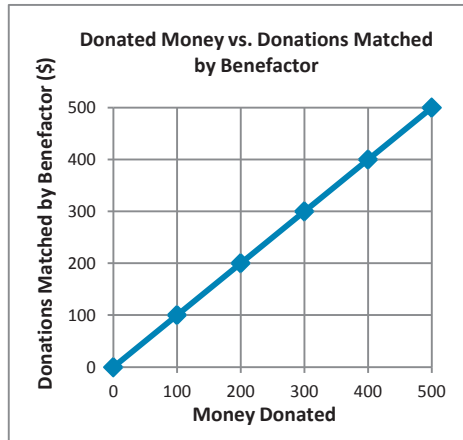

*This graph represents two quantities that are proportional to each other because the points appear on a line, and the line that passes through the points would also pass through the origin.*

b.

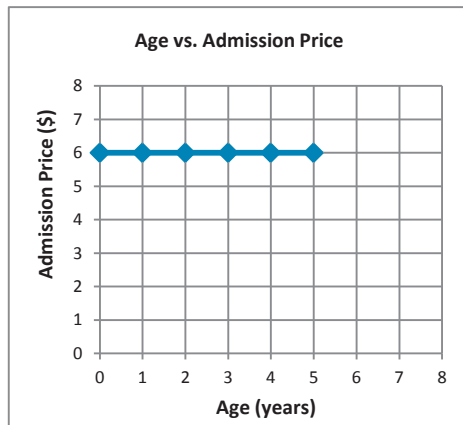

*Even though the points appear on a line, the line does not go through the origin. Therefore, this graph does not represent a proportional relationship.*

c.

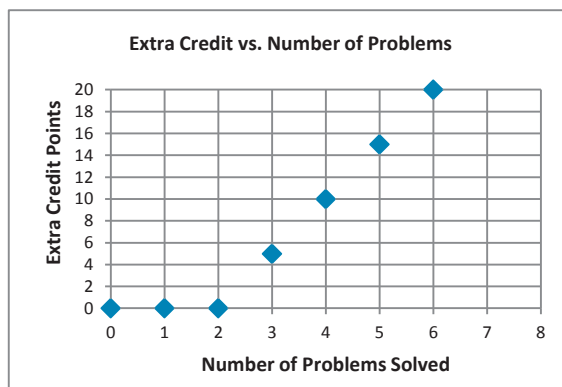

*Even though it goes through the origin, this graph does not show a proportional relationship because the points do not appear on one line.*

2. Create a table and a graph for the ratios 2:22, 3 to 15, and 1:11. Does the graph show that the two quantities are proportional to each other? Explain why or why not.

*This graph does not because the points do not appear on a line that goes through the origin.*

$x$	$y$
2	22
3	15
1	11

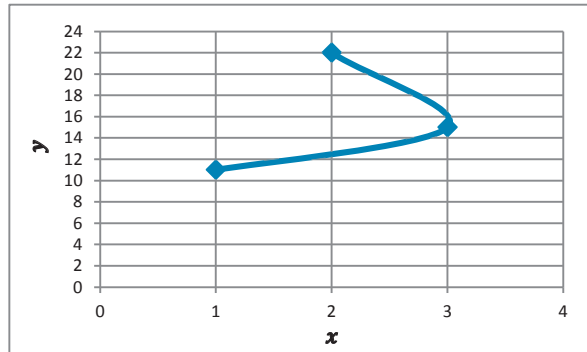

3. Graph the following tables, and identify if the two quantities are proportional to each other on the graph. Explain why or why not.

a.

$x$	$y$
3	1
6	2
9	3
12	4

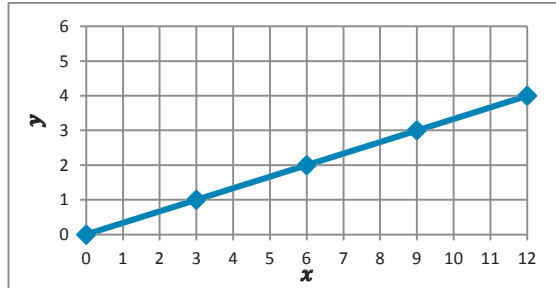

*Yes, because the graph of the relationship is a straight line that passes through the origin.*

b.

$x$	$y$
1	4
2	5
3	6
4	7

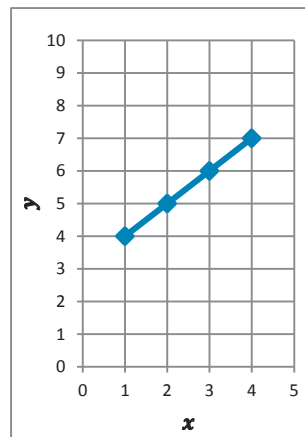

*No, because the graph does not pass through the origin.*





## Lesson 6: Identifying Proportional and Non-Proportional Relationships in Graphs

### Student Outcomes

- Students examine situations carefully to decide whether two quantities are proportional to each other by graphing on a coordinate plane and observing whether all the points would fall on a line that passes through the origin.
- Students study examples of relationships that are not proportional as well as those that are.

### Classwork

Today's Exploratory Challenge is an extension of Lesson 5. You will be working in groups to create a table and graph and to identify whether the two quantities are proportional to each other.

### Preparation (5 minutes)

Place students in groups of four. Hand out markers, poster paper, graph paper, and envelopes containing 5 ratios each. (Each group will have identical contents.) Lead students through the following directions to prepare for the Exploratory Challenge.

Have the recorder fold the poster paper in quarters and label as follows: Quad 1–Table, Quad 2–Problem, Quad 3–Graph, and Quad 4–Proportional or Not? Explanation.

Instruct the reader to take out the contents of the envelope (located at the end of the lesson), and instruct the group to arrange the data in a table and on a graph.

Instruct the reader to read the problem. The recorder should write the problem on the poster paper. Students use multiple methods to show whether the quantities represented in the envelope are proportional to each other.

### Exploratory Challenge (20 minutes)

Give students 15 minutes to discuss the problem and record their responses onto the poster paper. For the last 5 minutes, have groups place their posters on the wall and circulate around the room, looking for the groups that have the same ratios. Have groups with the same ratios identify and discuss the differences of their posters.

### Gallery Walk (10 minutes)

In groups, have students observe each poster, write any thoughts on sticky notes, and place them on the posters. Sample posters are provided below. Also, have students answer the following questions on their worksheets:

- Were there any differences found in groups that had the same ratios?
- Did you notice any common mistakes? How might they be fixed?
- Which posters were both visually attractive and informative?

Poster Layout

Use for notes

Group 1 and 8

**Problem:**  
A local frozen yogurt shop is known for their monster sundaes. Create a table, and then graph and explain if the quantities are proportional to each other.

**Table:**

Number of Toppings	Total Cost of Toppings (\$)
4	0
6	3
8	6
10	9
12	12

**Graph:**

**Explanation:**  
Although the points appear on a line, the quantities are not proportional to each other because the line does not go through the origin. Each topping does not have the same unit cost.

Group 2 and 7

**Problem:**  
The school library receives money for every book sold at the school's book fair. Create a table, and then graph and explain if the quantities are proportional to each other.

**Table:**

Number of Books Sold	Donations per Sponsor (\$)
1	5
2	10
3	15
4	20
5	25

**Graph:**

**Explanation:**  
The quantities are proportional to each other because the points appear on a line that goes through the origin. Each book sold brings in \$5.00, no matter how many books are sold.

Group 3 and 6

**Problem:**  
Your uncle just bought a hybrid car and wants to take you and your siblings camping. Create a table, and then graph and explain if the quantities are proportional to each other.

**Table:**

Gallons of Gas Left in Tank	Hours of Driving
8	0
6	1
4	4
2	7
0	8

**Graph:**

**Explanation:**  
The graph is not represented by a line passing through the origin, so the quantities are not proportional to each other. The number of gallons of gas varies depending on how fast or slow the car is driven.

Group 4 and 5

**Problem:**  
For a science project, Eli decided to study colonies of mold. He observed a piece of bread that was molding. Create a table, and then graph and explain if the quantities are proportional to each other.

**Table:**

Number of Days	Colonies of Mold
1	1
2	4
3	9
4	16
5	25

**Graph:**

**Explanation:**  
Although the graph looks as though it goes through the origin, the quantities are not proportional to each other because the points do not appear on a line. Each day does not produce the same amount of colonies as the other days.

**Gallery Walk**

Take notes and answer the following questions:

- Were there any differences found in groups that had the same ratios?
- Did you notice any common mistakes? How might they be fixed?
- Were there any groups that stood out by representing their problem and findings exceptionally clearly?

Poster 1:

Poster 2:

Poster 3:

Poster 4:

Poster 5:

Poster 6:

Poster 7:

Poster 8:

Note about Lesson Summary:

**Closing (5 minutes)**

- Why make posters with others? Why not do this exercise in your student books?
  - *We can discuss with others and learn from their thought processes. When we share information with others, our knowledge is tested and questioned.*
- What does it mean for a display to be both visually appealing and informative?
  - *For a display to be both visually appealing and informative, the reader should be able to find data and results fairly quickly and somewhat enjoyably.*
- Suppose we invited people from another school, state, or country to walk through our gallery. What would they be able to learn about ratio and proportion from our posters?
  - *Hopefully, after looking through the series of posters, people can learn and easily determine for themselves if graphs represent proportional and non-proportional relationships.*

**Lesson Summary**

The plotted points in a *graph of a proportional relationship* lie on a line that passes through the origin.

**Exit Ticket (5 minutes)**

Name \_\_\_\_\_

Date \_\_\_\_\_

## Lesson 6: Identifying Proportional and Non-Proportional Relationships in Graphs

### Exit Ticket

1. Which graphs in the gallery walk represented proportional relationships, and which did not? List the group number.

Proportional Relationship

Non-Proportional Relationship

2. What are the characteristics of the graphs that represent proportional relationships?

3. For the graphs representing proportional relationships, what does  $(0, 0)$  mean in the context of the given situation?

Exit Ticket Sample Solutions

1. Which graphs in the art gallery walk represented proportional relationships, and which did not? List the group number.

<u>Proportional Relationship</u>	<u>Non-Proportional Relationship</u>	
Group 2	Group 1	Group 5
Group 7	Group 3	Group 6
	Group 4	Group 8

2. What are the characteristics of the graphs that represent proportional relationships?

*Graphs of groups 2 and 7 appear on a line and go through the origin.*

3. For the graphs representing proportional relationships, what does (0, 0) mean in the context of the situation?

*For zero books sold, the library received zero dollars in donations.*

Problem Set Sample Solutions

Sally's aunt put money in a savings account for her on the day Sally was born. The savings account pays interest for keeping her money in the bank. The ratios below represent the number of years to the amount of money in the savings account.

- After one year, the interest accumulated, and the total in Sally's account was \$312.
- After three years, the total was \$340. After six years, the total was \$380.
- After nine years, the total was \$430. After 12 years, the total amount in Sally's savings account was \$480.

Using the same four-fold method from class, create a table and a graph, and explain whether the amount of money accumulated and time elapsed are proportional to each other. Use your table and graph to support your reasoning.

<p><u>Problem:</u></p> <p><i>Sally's aunt put money in a savings account for her on the day Sally was born. The savings account pays interest for keeping the money in the bank. The ratios below represent the number of years to the amount of money in the savings account. Create a table and a graph, and explain whether the quantities are proportional to each other.</i></p>	<p><u>Table:</u></p> <table border="1"> <thead> <tr> <th>Years</th> <th>Savings (\$)</th> </tr> </thead> <tbody> <tr> <td>1</td> <td>312</td> </tr> <tr> <td>3</td> <td>340</td> </tr> <tr> <td>6</td> <td>380</td> </tr> <tr> <td>9</td> <td>430</td> </tr> <tr> <td>12</td> <td>480</td> </tr> </tbody> </table>	Years	Savings (\$)	1	312	3	340	6	380	9	430	12	480
Years	Savings (\$)												
1	312												
3	340												
6	380												
9	430												
12	480												
<p><u>Graph:</u></p>	<p><u>Explanation:</u></p> <p><i>The graph is not a graph of a proportional relationship because, although the data appears to be a line, it is not a line that goes through the origin. The amount of interest collected is not the same every year.</i></p>												

## Ratios for Exploratory Challenge

Cut and place in labeled envelopes prior to instructional time.

<p><b>Group 1</b> A local frozen yogurt shop is known for its monster sundaes to be shared by a group. The ratios represent the number of toppings to the total cost of the toppings. Create a table, and then graph and explain if the quantities are proportional to each other.</p>	<p><b>Group 2</b> The school library receives money for every book sold at the school's book fair. The ratios represent the number of books sold to the amount of money the library receives. Create a table, and then graph and explain if the quantities are proportional to each other.</p>	<p><b>Group 3</b> Your uncle just bought a hybrid car and wants to take you and your siblings camping. The ratios represent the number of gallons of gas remaining to the number of hours of driving. Create a table, and then graph and explain if the quantities are proportional to each other.</p>	<p><b>Group 4</b> For a science project, Eli decided to study colonies of mold. He observed a piece of bread that was molding. The ratios represent the number of days passed to the number of colonies of mold on the bread. Create a table, and then graph and explain if the quantities are proportional to each other.</p>
4 to 0	1 to 5	8 to 0	1 to 1
6: 3	2 to 10	After 1 hour of driving, there are 6 gallons of gas left in the tank.	2 to 4
8: 6	The library received \$15 for selling 3 books.	4: 4	3: 9
The total cost of a 10-topping sundae is \$9.	4: 20	2 to 7	4: 16
12 to 12	5: 25	0: 8	Twenty-five colonies were found on the 5 <sup>th</sup> day.

<p><b>Group 5</b> For a science project, Eli decided to study colonies of mold. He observed a piece of bread that was molding. The ratios represent the number of days passed to the number of colonies of mold on the bread. Create a table, and then graph and explain if the quantities are proportional to each other.</p>	<p><b>Group 6</b> Your uncle just bought a hybrid car and wants to take you and your siblings camping. The ratios represent the number of gallons of gas remaining to the number of hours of driving. Create a table, and then graph and explain if the quantities are proportional to each other.</p>	<p><b>Group 7</b> The school library receives money for every book sold at the school's book fair. The ratios represent the number of books sold to the amount of money the library receives. Create a table, and then graph and explain if the quantities are proportional to each other.</p>	<p><b>Group 8</b> A local frozen yogurt shop is known for its monster sundaes to be shared by a group. The ratios represent the number of toppings to the total cost of the toppings. Create a table, and then graph and explain if the quantities are proportional to each other.</p>
1 to 1	8 to 0	1 to 5	4 to 0
2 to 4	After 1 hour of driving, there are 6 gallons of gas left in the tank.	2 to 10	6: 3
3: 9	4: 4	The library received \$15 for selling 3 books.	8: 6
4: 16	2 to 7	4: 20	The total cost of a 10-topping sundae is \$9.
Twenty-five colonies were found on the 5 <sup>th</sup> day.	0 : 8	5: 25	12 to 12



## Topic B

## Unit Rate and Constant of Proportionality

- Focus Standards:**
- Recognize and represent proportional relationships between quantities.
    - Identify the constant of proportionality (unit rate) in tables, graphs, equations, diagrams, and verbal descriptions of proportional relationships.
    - Represent proportional relationships by equations. *For example, if total cost  $t$  is proportional to the number  $n$  of items purchased at a constant price  $p$ , the relationship between the total cost and the number of items can be expressed as  $t = pn$ .*
    - Explain what a point  $(x, y)$  on the graph of a proportional relationship means in terms of the situation, with special attention to the points  $(0, 0)$  and  $(1, r)$  where  $r$  is the unit rate.
  - Use variables to represent quantities in a real-world or mathematical problem, and construct simple equations and inequalities to solve problems by reasoning about the quantities.
    - Solve word problems leading to equations of the form  $px + q = r$  and  $p(x + q) = r$ , where  $p$ ,  $q$ , and  $r$  are specific rational numbers. Solve equations of these forms fluently. Compare an algebraic solution to an arithmetic solution, identifying the sequence of the operations used in each approach. *For example, the perimeter of a rectangle is 54 cm. Its length is 6 cm. What is its width?*

**Instructional Days:** 4

**Lesson 7:** Unit Rate as the Constant of Proportionality (P)<sup>1</sup>

**Lessons 8–9:** Representing Proportional Relationships with Equations (P, P)

**Lesson 10:** Interpreting Graphs of Proportional Relationships (P)

<sup>1</sup>Lesson Structure Key: P-Problem Set Lesson, M-Modeling Cycle Lesson, E-Exploration Lesson, S-Socratic Lesson



In Topic B, students learn to identify the constant of proportionality by finding the unit rate in the collection of equivalent ratios. They represent this relationship with equations of the form  $y = kx$ , where  $k$  is the constant of proportionality. In Lessons 8 and 9, students derive the constant of proportionality from the description of a real-world context and relate the equation representing the relationship to a corresponding ratio table or graphical representation. Topic B concludes with students consolidating their graphical understandings of proportional relationships as they interpret the meanings of the points  $(0,0)$  and  $(1, r)$ , where  $r$  is the unit rate, in terms of the situation or context of a given problem.



## Lesson 7: Unit Rate as the Constant of Proportionality

### Student Outcomes

- Students identify the same value relating the measures of  $x$  and the measures of  $y$  in a proportional relationship as the constant of proportionality and recognize it as the unit rate in the context of a given situation.
- Students find and interpret the constant of proportionality within the contexts of problems.

### Lesson Notes

During the first year of implementation, students are still becoming familiar with unit rate. It is important for students to recognize that unit rate is found from the ratio  $B:A$ . This is crucial when making connections between the unit rate and the constant of proportionality. In most problems throughout this lesson, there are two possible constants of proportionality (the exception is Example 1). We have only provided the solutions using the constant of proportionality that best satisfies the context of the problem, but either constant of proportionality is acceptable.

### Classwork

#### Example 1 (20 minutes): National Forest Deer Population in Danger?

Begin this lesson by presenting the example. Guide students to complete necessary information in the student materials.

#### Scaffolding:

Use a map of a national forest or another local area that students are familiar with so that students who are not familiar with square miles can view a model.

#### Example 1: National Forest Deer Population in Danger?

Wildlife conservationists are concerned that the deer population might not be constant across the National Forest. The scientists found that there were 144 deer in a 16-square-mile area of the forest. In another part of the forest, conservationists counted 117 deer in a 13-square-mile area. Yet a third conservationist counted 216 deer in a 24-square-mile plot of the forest. Do conservationists need to be worried?

- a. Why does it matter if the deer population is not constant in a certain area of the National Forest?

*Have students generate as many theories as possible (e.g., food supply, overpopulation, damage to land).*

- b. What is the population density of deer per square mile?

*See table below.*

Encourage students to make a chart to organize the data from the problem, and then explicitly model finding the constant of proportionality. Students have already found unit rate in earlier lessons but have not identified it as the constant of proportionality.

- When we find the number of deer per 1 square mile, what is this called?
  - *Unit rate.*

- When we look at the relationship between square miles and number of deer in the table below, how do we know if the relationship is proportional?
  - *The square miles are always multiplied by the same value, 9 in this case.*

Square Miles ( $x$ )	Number of Deer ( $y$ )	
16	144	$\frac{144}{16} = 9$
13	117	$\frac{117}{13} = 9$
24	216	$\frac{216}{24} = 9$

- We call this constant (or same) value the *constant of proportionality*.
- So, the number of deer per square mile is 9, and the constant of proportionality is 9. Is that a coincidence, or will the unit rate of  $\frac{y}{x}$  and the constant of proportionality always be the same?

Allow for comments or observations, but leave a lingering question for now.

- We could add the unit rate to the table so that we have 1 square mile in the first column and 9 in the second column. (Add this to the table for students to see.) Does that help to guide your decision about the relationship between the unit rate of  $\frac{y}{x}$  and the constant of proportionality? We will see if your hypothesis remains true as we move through more examples.

*Note to Teacher:*

This could be completed after this concept is formalized in the next few examples.

The unit rate of deer per 1 square mile is 9.

Constant of Proportionality:  $k = 9$

Explain the meaning of the constant of proportionality in this problem: *There are 9 deer for every 1 square mile of forest.*

- c. Use the unit rate of deer per square mile (or  $\frac{y}{x}$ ) to determine how many deer there are for every 207 square miles.

$$9(207) = 1,863$$

*There are 1,863 deer for every 207 square miles.*

- d. Use the unit rate to determine the number of square miles in which you would find 486 deer.

$$\frac{486}{9} = 54$$

*In 54 square miles, you would find 486 deer.*

- Based upon the discussion of the questions above, answer the question: Do conservationists need to be worried? Be sure to support your answer with mathematical reasoning about rate and unit rate.

Review the vocabulary box with students.

#### Vocabulary

A *variable* is a symbol (such as a letter) that is a placeholder for a number.

If a proportional relationship is described by the set of ordered pairs  $(x, y)$  that satisfies the equation  $y = kx$  for some number  $k$ , then  $k$  is called the *constant of proportionality*. It is the number that describes the multiplicative relationship between measures,  $x$  and  $y$ , of two types of quantities. The  $(x, y)$  pairs represent all the pairs of numbers that make the equation true.

**Note:** In a given situation, it would be reasonable to assign any variable as a placeholder for the given measures. For example, a set of ordered pairs  $(t, d)$  would be all the points that satisfy the equation  $d = rt$ , where  $r$  is the constant of proportionality. This value for  $r$  specifies a number for the given situation.

Remind students that in the example with the deer population, we are looking for the number of deer per square mile, so the number of square miles could be defined as  $x$ , and the number of deer could be defined as  $y$ . The unit rate of deer per square mile is  $\frac{144}{16}$ , or 9. The constant of proportionality,  $k$ , is 9. The meaning in the context of Example 1 is as follows: There are 9 deer for every 1 square mile of forest.

Discuss the following question with students:

- How are the constant of proportionality and the unit rate of  $\frac{y}{x}$  alike?
  - They both represent the value of the ratio of  $y$  to  $x$ .

### Example 2 (9 minutes): You Need WHAT?

While working on Example 2, encourage students to make a chart to organize the data from the problem.

#### Example 2: You Need WHAT?

Brandon came home from school and informed his mother that he had volunteered to make cookies for his entire grade level. He needs 3 cookies for each of the 96 students in seventh grade. Unfortunately, he needs the cookies the very next day! Brandon and his mother determined that they can fit 36 cookies on two cookie sheets.

- a. Is the number of cookies proportional to the number of cookie sheets used in baking? Create a table that shows data for the number of sheets needed for the total number of cookies baked.

Table:

Number of Cookie Sheets	Number of Cookies Baked	
2	36	$\frac{36}{2} = 18$
4	72	$\frac{72}{4} = 18$
10	180	$\frac{180}{10} = 18$
16	288	$\frac{288}{16} = 18$

The unit rate of  $\frac{y}{x}$  is 18.

Constant of Proportionality:  $k = 18$

Explain the meaning of the constant of proportionality in this problem: *There are 18 cookies per 1 cookie sheet.*

#### Scaffolding:

For students who need more challenge, have them create a problem in which the constant rate is a fraction.

- b. It takes 2 hours to bake 8 sheets of cookies. If Brandon and his mother begin baking at 4:00 p.m., when will they finish baking the cookies?

$$96 \text{ students (3 cookies per student)} = 288 \text{ cookies}$$

$$\frac{288 \text{ cookies}}{18 \text{ cookies per sheet}} = 16 \text{ sheets of cookies}$$

*If it takes 2 hours to bake 8 sheets, it will take 4 hours to bake 16 sheets of cookies. They will finish baking at 8:00 p.m.*

### Example 3 (9 minutes): French Class Cooking

#### Example 3: French Class Cooking

Suzette and Margo want to prepare crêpes for all of the students in their French class. A recipe makes 20 crêpes with a certain amount of flour, milk, and 2 eggs. The girls already know that they have plenty of flour and milk to make 50 crêpes, but they need to determine the number of eggs they will need for the recipe because they are not sure they have enough.

- a. Considering the amount of eggs necessary to make the crêpes, what is the constant of proportionality?

$$\frac{20}{2} = 10$$

*The constant of proportionality is 10.*

- b. What does the constant or proportionality mean in the context of this problem?

*One egg is needed to make 10 crêpes.*

- c. How many eggs are needed to make 50 crêpes?

$$50 \left( \frac{1}{10} \right) = 5$$

*Five eggs are needed to make 50 crêpes.*

### Closing (2 minutes)

- What is another name for the constant that relates the measures of two quantities?
  - *Another name for the constant is the constant of proportionality.*
- How is the constant of proportionality related to the unit rate of  $\frac{y}{x}$ ?
  - *They represent the value of the ratio  $y : x$ .*

#### Lesson Summary

If a proportional relationship is described by the set of ordered pairs  $(x, y)$  that satisfies the equation  $y = kx$  for some number  $k$ , then  $k$  is called the *constant of proportionality*.

### Exit Ticket (5 minutes)

Name \_\_\_\_\_

Date \_\_\_\_\_

## Lesson 7: Unit Rate as the Constant of Proportionality

### Exit Ticket

Susan and John are buying cold drinks for a neighborhood picnic. Each person is expected to drink one can of soda. Susan says that if you multiply the unit price for a can of soda by the number of people attending the picnic, you will be able to determine the total cost of the soda. John says that if you divide the cost of a 12-pack of soda by the number of sodas, you will determine the total cost of the sodas. Who is right, and why?

## Exit Ticket Sample Solutions

Susan and John are buying cold drinks for a neighborhood picnic. Each person is expected to drink one can of soda. Susan says that if you multiply the unit price for a can of soda by the number of people attending the picnic, you will be able to determine the total cost of the soda. John says that if you divide the cost of a 12-pack of soda by the number of sodas, you will determine the total cost of the sodas. Who is right, and why?

*Susan is correct. The table below shows that if you multiply the unit price, say 0.50, by the number of people, say 12, you will determine the total cost of the soda. I created a table to model the proportional relationship. I used a unit price of 0.50 to make the comparison.*

*Susan*

<i>Number of People</i>	2	3	4	12
<i>Total Cost of Soda (in dollars)</i>	1	1.50	2	6

*I used the same values to compare to John.  $\frac{\text{total cost}}{12 \text{ people}} = ?$*

*The total cost is \$6, and there 12 people.  $\frac{6}{12} = \frac{1}{2}$ , which is \$0.50 or the unit price, not the total cost.*

## Problem Set Sample Solutions

For each of the following problems, define the constant of proportionality to answer the follow-up question.

1. Bananas are \$0.59/pound.

- a. What is the constant of proportionality, or  $k$ ?

*The constant of proportionality,  $k$ , is 0.59.*

- b. How much will 25 pounds of bananas cost?

*25 lb. (\$0.59/lb.) = \$14.75*

2. The dry cleaning fee for 3 pairs of pants is \$18.

- a. What is the constant of proportionality?

*$\frac{18}{3} = 6$ , so  $k$  is 6.*

- b. How much will the dry cleaner charge for 11 pairs of pants?

*6(11) = 66*

*The dry cleaner would charge \$66.*

3. For every \$5 that Micah saves, his parents give him \$10.

- a. What is the constant of proportionality?

*$\frac{10}{5} = 2$ , so  $k$  is 2.*

- b. If Micah saves \$150, how much money will his parents give him?

$$2(\$150) = \$300$$

4. Each school year, the seventh graders who study Life Science participate in a special field trip to the city zoo. In 2010, the school paid \$1,260 for 84 students to enter the zoo. In 2011, the school paid \$1,050 for 70 students to enter the zoo. In 2012, the school paid \$1,395 for 93 students to enter the zoo.

- a. Is the price the school pays each year in entrance fees proportional to the number of students entering the zoo?

<i>Number of Students</i>	<i>Price (\$)</i>	
84	1,260	$\frac{1260}{84} = 15$
70	1,050	$\frac{1050}{70} = 15$
93	1,395	$\frac{1395}{93} = 15$

} YES

- b. Explain why or why not.

*The price is proportional to the number of students because the ratio of the entrance fee paid per student was the same.*

$$\frac{1260}{84} = 15$$

- c. Identify the constant of proportionality and explain what it means in the context of this situation.

*The constant of proportionality (k) is 15. This represents the price per student.*

- d. What would the school pay if 120 students entered the zoo?

$$120 \text{ students } (\$15 \text{ per student}) = \$1800$$

- e. How many students would enter the zoo if the school paid \$1,425?

$$\frac{1425}{15} = 95 \text{ students}$$





## Lesson 8: Representing Proportional Relationships with Equations

### Student Outcomes

- Students use the constant of proportionality to represent proportional relationships by equations in real-world contexts as they relate the equations to a corresponding ratio table or graphical representation.

### Classwork

#### Discussion (5 minutes)

##### Points to remember:

- Proportional relationships have a constant ratio, or unit rate.
- The constant ratio, or unit rate of  $\frac{y}{x}$ , can also be called the constant of proportionality.

##### Discussion Notes

How could we use what we know about the constant of proportionality to write an equation?

Discuss important facts.

Encourage students to begin thinking about how we can model a proportional relationship using an equation by asking the following probing questions:

- If we know that the constant of proportionality,  $k$ , is equal to  $\frac{y}{x}$  for a given set of ordered pairs,  $x$  and  $y$ , then we can write  $k = \frac{y}{x}$ . How else could we write this equation? What if we know the  $x$ -values and the constant of proportionality, but do not know the  $y$ -values? Could we rewrite this equation to solve for  $y$ ?

Elicit ideas from students. Apply their ideas in the examples below. Provide the context of the examples below to encourage students to test their thinking.

Students should note the following in their student materials:  $k = \frac{y}{x}$  and eventually  $y = kx$ . (This second equation may be needed after Example 1).

## Examples 1–2 (33 minutes)

Write an equation that will model the real-world situation.

**Example 1: Do We Have Enough Gas to Make It to the Gas Station?**

Your mother has accelerated onto the interstate beginning a long road trip, and you notice that the low fuel light is on, indicating that there is a half a gallon left in the gas tank. The nearest gas station is 26 miles away. Your mother keeps a log where she records the mileage and the number of gallons purchased each time she fills up the tank. Use the information in the table below to determine whether you will make it to the gas station before the gas runs out. You know that if you can determine the amount of gas that her car consumes in a particular number of miles, then you can determine whether or not you can make it to the next gas station.

Mother's Gas Record

Gallons	Miles Driven
8	224
10	280
4	112

- a. Find the constant of proportionality, and explain what it represents in this situation.

Gallons	Miles Driven	
8	224	$\frac{224}{8} = 28$
10	280	$\frac{280}{10} = 28$
4	112	$\frac{112}{4} = 28$

*The constant of proportionality,  $k$ , is 28. The car travels 28 miles for every one gallon of gas.*

- b. Write equation(s) that will relate the miles driven to the number of gallons of gas.

$$y = 28x \text{ or } m = 28g$$

- c. Knowing that there is a half gallon left in the gas tank when the light comes on, will she make it to the nearest gas station? Explain why or why not.

*No, she will not make it because she gets 28 miles to one gallon. Since she has  $\frac{1}{2}$  gallon remaining in the gas tank, she can travel 14 miles. Since the nearest gas station is 26 miles away, she will not have enough gas.*

- d. Using the equation found in part (b), determine how far your mother can travel on 18 gallons of gas. Solve the problem in two ways: once using the constant of proportionality and once using an equation.

*Using arithmetic:  $28(18) = 504$*

*Using an equation:  $m = 28g$  – Use substitution to replace the  $g$  (gallons of gas) with 18.*

*$m = 28(18)$  – This is the same as multiplying by the constant of proportionality.*

*$m = 504$*

*Your mother can travel 504 miles on 18 gallons of gas.*

- e. Using the constant of proportionality, and then the equation found in part (b), determine how many gallons of gas would be needed to travel 750 miles.

Using arithmetic:  $\frac{750}{28} = 26.8$

Using algebra:

$$\begin{aligned} m &= 28g \\ 750 &= 28g \\ \left(\frac{1}{28}\right)750 &= \left(\frac{1}{28}\right)28g \\ 26.8 &= 1g \end{aligned}$$

– Use substitution to replace the  $m$  (miles driven) with 750.

– This equation demonstrates dividing by the constant of proportionality or using the multiplicative inverse to solve the equation.

26.8 (rounded to the nearest tenth) gallons would be needed to drive 750 miles.

Have students write the pairs of numbers in the chart as ordered pairs. Explain that in this example,  $x$  represents the number of gallons of gas, and  $y$  represents the number of miles driven. Remind students to think of the constant of proportionality as  $k = \frac{y}{x}$ . In this case, the constant of proportionality is a certain number of miles divided by a certain number of gallons of gas. This constant is the same as the unit rate of miles per gallon of gas. Remind students that you will use the constant of proportionality (or unit rate) as a multiplier in your equation.

- Write equation(s) that will relate the miles driven to the number of gallons of gas.

In order to write the equation to represent this situation, direct students to think of the independent and dependent variables that are implied in this problem.

- Which part depends on the other for its outcome?
  - *The number of miles driven depends on the number of gallons of gas that are in the gas tank.*
- Which is the dependent variable: the number of gallons of gas or the amount of miles driven?
  - *The number of miles driven is the dependent variable, and the number of gallons of gas is the independent variable.*

Tell students that  $x$  is usually known as the independent variable, and  $y$  is known as the dependent variable.

Remind students that the constant of proportionality can also be expressed as  $\frac{y}{x}$  from an ordered pair. It is the value of the ratio of the dependent variable to the independent variable.

- When  $x$  and  $y$  are graphed on a coordinate plane, which axis would show the values of the dependent variable?
  - *y-axis*
- The independent variable?
  - *x-axis*

Tell students that any variable may be used to represent the situation as long as it is known that in showing a proportional relationship in an equation that the constant of proportionality is multiplied by the independent variable. In this problem, students can write  $y = 28x$ , or  $m = 28g$ . We are substituting  $k$  with 28 in the equation  $y = kx$ , or  $m = kg$ .

Tell students that this equation models the situation and provides them with a way to determine either variable when the other is known. If the equation is written so a variable can be substituted with the known information, then students can use algebra to solve the equation.

**Example 2: Andrea's Portraits**

Andrea is a street artist in New Orleans. She draws caricatures (cartoon-like portraits) of tourists. People have their portrait drawn and then come back later to pick it up from her. The graph below shows the relationship between the number of portraits she draws and the amount of time in hours she needs to draw the portraits.

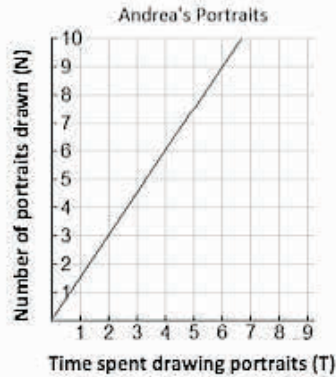

- a. Write several ordered pairs from the graph, and explain what each ordered pair means in the context of this graph.

$(4, 6)$  means that in 4 hours, she can draw 6 portraits.

$(6, 9)$  means that in 6 hours, she can draw 9 portraits.

$(2, 3)$  means that in 2 hours, she can draw 3 portraits.

$(1, 1\frac{1}{2})$  means that in 1 hour, she can draw  $1\frac{1}{2}$  portraits.

- b. Write several equations that would relate the number of portraits drawn to the time spent drawing the portraits.

$$\left. \begin{array}{l} N = \frac{3}{2}T \\ N = \frac{6}{4}T \\ N = \frac{9}{6}T \end{array} \right\} \boxed{\frac{3}{2} = \frac{6}{4} = \frac{9}{6} = 1\frac{1}{2}}$$

- c. Determine the constant of proportionality, and explain what it means in this situation.

The constant of proportionality is  $\frac{3}{2}$ , which means that Andrea can draw 3 portraits in 2 hours or can complete  $1\frac{1}{2}$  portraits in 1 hour.

Tell students that these ordered pairs can be used to generate the constant of proportionality, and write the equation for this situation. Remember that  $k = \frac{y}{x}$ .

**Closing (2 minutes)**

- How can unit rate be used to write an equation relating two variables that are proportional?
  - *The unit rate of  $\frac{y}{x}$  is the constant of proportionality,  $k$ . After computing the value for  $k$ , it may be substituted in place of  $k$  in the equation  $y = kx$ . The constant of proportionality can be multiplied by the independent variable to find the dependent variable, and the dependent variable can be divided by the constant of proportionality to find the independent variables.*

**Lesson Summary**

If a proportional relationship is described by the set of ordered pairs that satisfies the equation  $y = kx$ , where  $k$  is a positive constant, then  $k$  is called the *constant of proportionality*. The constant of proportionality expresses the multiplicative relationship between each  $x$ -value and its corresponding  $y$ -value.

**Exit Ticket (5 minutes)**

Name \_\_\_\_\_

Date \_\_\_\_\_

## Lesson 8: Representing Proportional Relationships with Equations

### Equations

#### Exit Ticket

John and Amber work at an ice cream shop. The hours worked and wages earned are given for each person.

John's Wages	
Time (in hours)	Wages (in dollars)
2	18
3	27
4	36

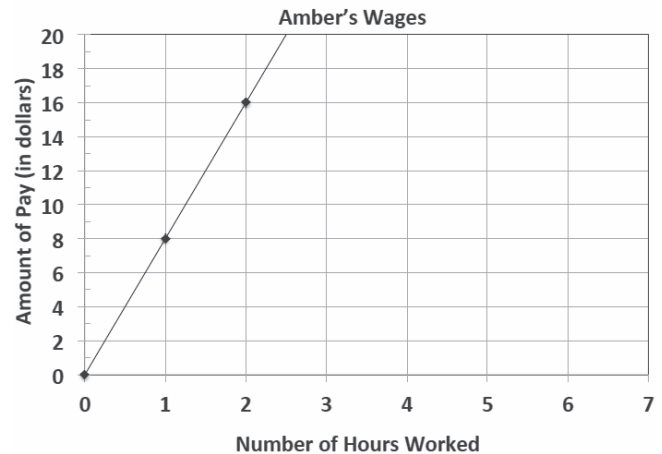

- Determine if John's wages are proportional to time. If they are, determine the unit rate of  $\frac{y}{x}$ . If not, explain why they are not.



## Exit Ticket Sample Solutions

John and Amber work at an ice cream shop. The hours worked and wages earned are given for each person.

John's Wages		
Time (in hours)	Wages (in dollars)	
2	18	$\frac{18}{2} = 9$
3	27	$\frac{27}{3} = 9$
4	36	$\frac{36}{4} = 9$

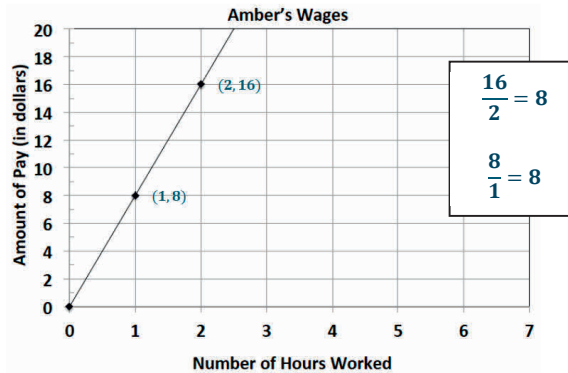

- Determine if John's wages are proportional to time. If they are, determine the unit rate of  $\frac{y}{x}$ . If not, explain why they are not.  
*Yes, the unit rate is 9. The collection of ratios is equivalent.*

- Determine if Amber's wages are proportional to time. If they are, determine the unit rate of  $\frac{y}{x}$ . If not, explain why they are not.  
*Yes, the unit rate is 8. The collection of ratios is equivalent.*

- Write an equation for both John and Amber that models the relationship between their wage and the time they worked. Identify the constant of proportionality for each. Explain what it means in the context of the situation.

*John:  $w = 9h$ ; the constant of proportionality is 9; John earns \$9 for every hour he works.*

*Amber:  $w = 8h$ ; the constant of proportionality is 8; Amber earns \$8 for every hour she works.*

- How much would each worker make after working 10 hours? Who will earn more money?

*After 10 hours, John will earn \$90 because 10 hours is the value of the independent variable, which should be multiplied by  $k$ , the constant of proportionality.  $w = 9h$ ;  $w = 9(10)$ ;  $w = 90$ . After 10 hours, Amber will earn \$80 because her equation is  $w = 8h$ ;  $w = 8(10)$ ;  $w = 80$ . John will earn more money than Amber in the same amount of time.*

- How long will it take each worker to earn \$50?

*To determine how long it will take John to earn \$50, the dependent value will be divided by 9, the constant of proportionality. Algebraically, this can be shown as a one-step equation:  $50 = 9h$ ;  $(\frac{1}{9}) 50 = (\frac{1}{9}) 9h$ ;  $\frac{50}{9} = 1h$ ;  $5.56 = h$  (round to the nearest hundredth). It will take John nearly 6 hours to earn \$50. To find how long it will take Amber to earn \$50, divide by 8, the constant of proportionality.  $50 = 8h$ ;  $(\frac{1}{8}) 50 = (\frac{1}{8}) 8h$ ;  $\frac{50}{8} = 1h$ ;  $6.25 = h$ . It will take Amber 6.25 hours to earn \$50.*



## Problem Set Sample Solutions

Write an equation that will model the proportional relationship given in each real-world situation.

1. There are 3 cans that store 9 tennis balls. Consider the number of balls per can.

- a. Find the constant of proportionality for this situation.

$$\frac{9 \text{ balls } (B)}{3 \text{ cans } (C)} = 3 \frac{\text{balls}}{\text{can}}$$

*The constant of proportionality is 3.*

- b. Write an equation to represent the relationship.

$$B = 3C$$

2. In 25 minutes, Li can run 10 laps around the track. Determine the number of laps she can run per minute.

- a. Find the constant of proportionality in this situation.

$$\frac{10 \text{ laps } (L)}{25 \text{ minutes } (M)} = \frac{2 \text{ laps}}{5 \text{ minute}}$$

*The constant of proportionality is  $\frac{2}{5}$ .*

- b. Write an equation to represent the relationship.

$$L = \frac{2}{5}M$$

3. Jennifer is shopping with her mother. They pay \$2 per pound for tomatoes at the vegetable stand.

- a. Find the constant of proportionality in this situation.

$$\frac{2 \text{ dollars } (D)}{1 \text{ pound } (P)} = 2 \frac{\text{dollars}}{\text{pound}}$$

*The constant of proportionality is 2.*

- b. Write an equation to represent the relationship.

$$D = 2P$$

4. It costs \$15 to send 3 packages through a certain shipping company. Consider the number of packages per dollar.

- a. Find the constant of proportionality for this situation.

$$\frac{3 \text{ packages } (P)}{15 \text{ dollars } (D)} = \frac{3 \text{ packages}}{15 \text{ dollar}}$$

*The constant of proportionality is  $\frac{1}{5}$ .*

- b. Write an equation to represent the relationship.

$$P = \frac{1}{5}D$$

5. On average, Susan downloads 60 songs per month. An online music vendor sells package prices for songs that can be downloaded onto personal digital devices. The graph below shows the package prices for the most popular promotions. Susan wants to know if she should buy her music from this company or pay a flat fee of \$58.00 per month offered by another company. Which is the better buy?

Number of Songs Purchased ( <i>S</i> )	Total Cost ( <i>C</i> )	Constant of Proportionality
40	36	$\frac{36}{40} = \frac{9}{10} = 0.9$
20	18	$\frac{18}{20} = \frac{9}{10} = 0.9$
12	10.80	$\frac{10.80}{12} = \frac{9}{10} = 0.9$
5	4.50	$\frac{4.50}{5} = \frac{9}{10} = 0.9$

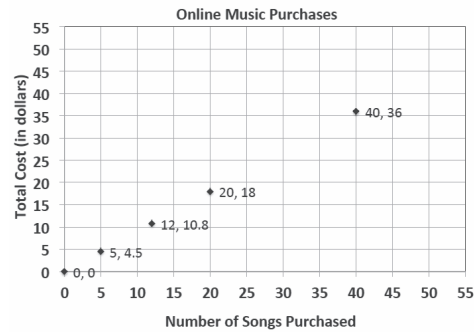

- a. Find the constant of proportionality for this situation.

*The constant of proportionality,  $k$ , is 0.9.*

- b. Write an equation to represent the relationship.

$$C = 0.9S$$

- c. Use your equation to find the answer to Susan’s question above. Justify your answer with mathematical evidence and a written explanation.

*Compare the flat fee of \$58 per month to \$0.90 per song. If  $C = 0.9S$  and we substitute  $S$  with 60 (the number of songs), then the result is  $C = 0.9(60) = 54$ . She would spend \$54 on songs if she bought 60 songs. If she maintains the same number of songs, the charge of \$0.90 per song would be cheaper than the flat fee of \$58 per month.*

6. Allison’s middle school team has designed t-shirts containing their team name and color. Allison and her friend Nicole have volunteered to call local stores to get an estimate on the total cost of purchasing t-shirts. Print-o-Rama charges a set-up fee, as well as a fixed amount for each shirt ordered. The total cost is shown below for the given number of shirts. Value T’s and More charges \$8 per shirt. Which company should they use?

Print-o-Rama

Number of Shirts ( <i>S</i> )	Total Cost ( <i>C</i> )
10	95
25	
50	375
75	
100	

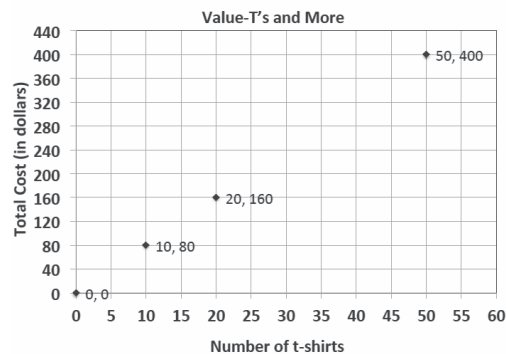

- a. Does either pricing model represent a proportional relationship between the quantity of t-shirts and the total cost? Explain.

*The unit rate of  $\frac{y}{x}$  for Print-o-Rama is not constant. The graph for Value T's and More is proportional since the ratios are equivalent (8) and the graph shows a line through the origin.*

- b. Write an equation relating cost and shirts for Value T's and More.

*$C = 8S$  for Value T's and More*

- c. What is the constant of proportionality of Value T's and More? What does it represent?

*8; the cost of one shirt is \$8.*

- d. How much is Print-o-Rama's set-up fee?

*The set-up fee is \$25.*

- e. If you need to purchase 90 shirts, write a proposal to your teacher indicating which company the team should use. Be sure to support your choice. Determine the number of shirts that you need for your team.

*Since we plan on a purchase of 90 shirts, we should choose Print-o-Rama.*

*Print-o-Rama:  $C = 7S + 25$ ;  $C = 7(90) + 25$ ;  $C = 655$*

*Value T's and More:  $C = 8S$ ;  $C = 8(90)$ ;  $C = 720$*



## Lesson 9: Representing Proportional Relationships with Equations

### Student Outcomes

- Students use the constant of proportionality to represent proportional relationships by equations in real-world contexts as they relate the equations to a corresponding ratio table or graphical representation.

### Classwork

Students begin to write equations in two variables. They analyze data that helps them understand the constant of proportionality and write the equation with two variables. The teacher may need to explicitly connect the graphical and tabular representations by modeling them side by side.

#### Example 1 (18 minutes): Jackson's Birdhouses

##### Example 1: Jackson's Birdhouses

Jackson and his grandfather constructed a model for a birdhouse. Many of their neighbors offered to buy the birdhouses. Jackson decided that building birdhouses could help him earn money for his summer camp, but he is not sure how long it will take him to finish all of the requests for birdhouses. If Jackson can build 7 birdhouses in 5 hours, write an equation that will allow Jackson to calculate the time it will take him to build any given number of birdhouses, assuming he works at a constant rate.

- Write an equation that you could use to find out how long it will take him to build any number of birdhouses.

$$H = \frac{5}{7}B$$

Define the variables.  $B$  represents the number of birdhouses, and  $H$  represents the number of hours (time constructing birdhouses).

- Does it matter which of these variables is independent or dependent?
  - No. The number of birdhouses made could depend on how much time Jackson can work, or the amount of time he works could depend on how many birdhouses he needs to make.
- If it is important to determine the number of birdhouses that can be built in one hour, what is the constant of proportionality?
  - $\frac{\text{number of birdhouses}}{\text{number of hours}}$  is  $\frac{7}{5}$ , or 1.4.
- What does that mean in the context of this situation?
  - It means that Jackson can build 1.4 birdhouses in one hour or one entire birdhouse and part of a second birdhouse in one hour.

- If it is important to determine the number of hours it takes to build one birdhouse, what is the constant of proportionality?
  - $\frac{\text{number of hours}}{\text{number of birdhouses}}$  is  $\frac{5}{7}$  or 0.71, which means that it takes him  $\frac{5}{7}$  of an hour to build one birdhouse or  $\left(\frac{5}{7}\right)(60) = 43$  minutes to build one birdhouse.
- This part of the problem asks you to write an equation that will let Jackson determine how long it will take him to build any number of birdhouses, so we want to know the value of  $H$ . This forces  $H$  to be the dependent variable and  $B$  to be the independent variable. Our constant of proportionality will be  $\frac{\text{dependent}}{\text{independent}}$ , which is  $\frac{H}{B}$  or  $\frac{y}{x}$ .  $\frac{y}{x}$  is  $\frac{5}{7}$ , so we will use the equation  $H = \frac{5}{7}B$ .

Use the equation above to determine the following:

- b. How many birdhouses can Jackson build in 40 hours?

*If  $H = \frac{5}{7}B$  and  $H = 40$ , then substitute 40 in the equation for  $H$  and solve for  $B$  since the question asks for the number of birdhouses.*

$$\begin{aligned} 40 &= \left(\frac{5}{7}\right)B \\ \left(\frac{7}{5}\right)40 &= \left(\frac{7}{5}\right)\left(\frac{5}{7}\right)B \\ 56 &= B \end{aligned}$$

*Jackson can build 56 birdhouses in 40 hours.*

- c. How long will it take Jackson to build 35 birdhouses? Use the equation from part (a) to solve the problem.

*If  $H = \frac{5}{7}B$  and  $B = 35$ , then substitute 35 into the equation for  $B$ ;  $H = \left(\frac{5}{7}\right)(35)$ ;  $H = 25$ . It will take Jackson 25 hours to build 35 birdhouses.*

- d. How long will it take to build 71 birdhouses? Use the equation from part (a) to solve the problem.

*If  $H = \frac{5}{7}B$  and  $B = 71$ , then substitute 71 for  $B$  into the equation;  $H = \left(\frac{5}{7}\right)(71)$ ;  $H = 50.7$  (rounded to the nearest tenth). It will take Jackson 50 hours and 42 minutes ( $60(0.7)$ ) to build 71 birdhouses.*

Remind students that while one may work for a fractional part of an hour, a customer will not want to buy a partially built birdhouse. Tell students that some numbers can be left as non-integer answers (e.g., parts of an hour that can be written as minutes), but others must be rounded to whole numbers (e.g., the number of birdhouses completed or sold). All of this depends on the context. We must consider the real-life context before we determine if and how we round.

### Example 2 (17 minutes): Al's Produce Stand

Let students select any two pairs of numbers from either Al's Produce Stand or Barbara's Produce Stand to calculate the constant of proportionality ( $k = \text{dependent/independent}$ ). In order to determine the unit price, students need to divide the cost (dependent variable) by the number of ears of corn (independent variable). Lead them through the following questions to organize their thinking.

- Which makes more sense: a rate whose unit is “ears per dollar” or a rate whose unit is “dollars per ear”?
  - *Dollars per ear of corn makes more sense because corn is sold as an entire ear of corn, not part of an ear of corn.*
- Based on the previous question, which will be the independent variable?
  - *The independent variable will be the number of ears of corn.*
- Which will be the dependent variable, and why?
  - *The cost will be the dependent variable because the cost depends on the number of ears of corn purchased.*

Have students volunteer to share the pair of numbers they used to determine the unit rate, or constant of proportionality, and compare the values for Al’s Produce Stand and for Barbara’s Produce Stand.

- *Al’s Produce Stand: 0.25 and Barbara’s Produce Stand: 0.24*
- How do you write an equation for a proportional relationship?
  - $y = kx$
- Write the equation for Al’s Produce Stand:
  - $y = 0.25x$
- Write the equation for Barbara’s Produce Stand:
  - $y = 0.24x$

**Example 2: Al’s Produce Stand**

Al’s Produce Stand sells 6 ears of corn for \$1.50. Barbara’s Produce Stand sells 13 ears of corn for \$3.12. Write two equations, one for each produce stand, that model the relationship between the number of ears of corn sold and the cost. Then, use each equation to help complete the tables below.

*Al’s Produce Stand:  $y = 0.25x$ ; where  $x$  represents the number of ears of corn, and  $y$  represents the cost*

*Barbara’s Produce Stand:  $y = 0.24x$ ; where  $x$  represents the number of ears of corn, and  $y$  represents the cost*

Al’s Produce Stand					Barbara’s Produce Stand				
Ears	6	14	21	200	Ears	13	14	21	208
Cost	\$1.50	\$3.50	\$5.25	\$50.00	Cost	\$3.12	\$3.36	\$5.04	\$49.92

- If you use  $E$  to represent the number of ears of corn and  $C$  to represent the cost for the variables instead of  $x$  and  $y$ , how would you write the equations?
  - $C = 0.25E$  and  $C = 0.24E$

**Closing (5 minutes)**

- What type of relationship can be modeled using an equation in the form  $y = kx$ , and what do you need to know to write an equation in this form?
  - *A proportional relationship can be modeled using an equation in the form  $y = kx$ . You need to know the constant of proportionality, which is represented by  $k$  in the equation.*

- Give an example of a real-world relationship that can be modeled using this type of equation, and explain why.
  - *Distance equals rate multiplied by time. If the rate of a vehicle is going at an unchanging speed (constant), then the distance will depend on time elapsed.*
- Give an example of a real-world relationship that cannot be modeled using this type of equation, and explain why.
  - *Distance is a dependent variable, and time is an independent variable because time is being multiplied by the rate.*

**Lesson Summary**

How do you find the constant of proportionality? Divide to find the unit rate,  $\frac{y}{x} = k$ .

How do you write an equation for a proportional relationship?  $y = kx$ , substituting the value of the constant of proportionality in place of  $k$ .

What is the structure of proportional relationship equations, and how do we use them?  $x$  and  $y$  values are always left as variables, and when one of them is known, they are substituted into  $y = kx$  to find the unknown using algebra.

**Exit Ticket (5 minutes)**

Name \_\_\_\_\_

Date \_\_\_\_\_

## Lesson 9: Representing Proportional Relationships with Equations

### Exit Ticket

Oscar and Maria each wrote an equation that they felt represented the proportional relationship between distance in kilometers and distance in miles. One entry in the table paired 152 km with 95 miles. If  $k$  represents the number of kilometers and  $m$  represents the number of miles, who wrote the correct equation that would relate kilometers to miles? Explain why.

Oscar wrote the equation  $k = 1.6m$ , and he said that the unit rate  $\frac{1.6}{1}$  represents kilometers per mile.

Maria wrote the equation  $k = 0.625m$  as her equation, and she said that 0.625 represents kilometers per mile.



## Exit Ticket Sample Solutions

Oscar and Maria each wrote an equation that they felt represented the proportional relationship between distance in kilometers and distance in miles. One entry in the table paired 152 km with 95 miles. If  $k$  represents the number of kilometers and  $m$  represents the number of miles, who wrote the correct equation that would relate kilometers to miles? Explain why.

Oscar wrote the equation  $k = 1.6m$ , and he said that the unit rate  $\frac{1.6}{1}$  represents kilometers per mile.

Maria wrote the equation  $k = 0.625m$  as her equation, and she said that 0.625 represents kilometers per mile.

*Oscar is correct. Oscar found the unit rate to be 1.6 by dividing kilometers by miles. The unit rate that Oscar used represents the number of kilometers per the number of miles. However, it should be noted that the variables were not well defined. Since we do not know which values are independent or dependent, each equation should include a definition of each variable. For example, Oscar should have defined his variables so that  $k$  represented the number of kilometers and  $m$  represented the number of miles. For Maria's equation to be correct, she should have stated that  $k$  represents the number of miles and  $m$  represents the number of kilometers.*

## Problem Set Sample Solutions

1. A person who weighs 100 pounds on Earth weighs 16.6 lb. on the moon.

- a. Which variable is the independent variable? Explain why.

*Weight on Earth is the independent variable because most people do not fly to the moon to weigh themselves first. The weight on the moon depends on a person's weight on Earth.*

- b. What is an equation that relates weight on Earth to weight on the moon?

$$M = \left(\frac{16.6}{100}\right)E$$

$$M = 0.166E$$

- c. How much would a 185-pound astronaut weigh on the moon? Use an equation to explain how you know.

30.71 lb.

- d. How much would a man who weighs 50 pounds on the moon weigh on Earth?

301 lb.

2. Use this table to answer the following questions.

Number of Gallons of Gas	Number of Miles Driven
0	0
2	62
4	124
10	310

- a. Which variable is the dependent variable, and why?

*The number of miles driven is the dependent variable because the number of miles you can drive depends on the number of gallons of gas you have in your tank.*

- b. Is the number of miles driven proportionally related to the number of gallons of gas? If so, what is the equation that relates the number of miles driven to the number of gallons of gas?

*Yes, the number of miles driven is proportionally related to the number of gallons of gas because every measure of gallons of gas can be multiplied by 31 to get every corresponding measure of miles driven.*

$$M = 31G$$

- c. In any ratio relating the number of gallons of gas and the number of miles driven, will one of the values always be larger? If so, which one?

*Yes, the number of miles will be larger except for the point (0, 0). The point (0, 0) means 0 miles driven uses 0 gallons of gas.*

- d. If the number of gallons of gas is known, can you find the number of miles driven? Explain how this value would be calculated.

*Yes, multiply the constant of proportionality (31 mpg) by the number of gallons of gas.*

- e. If the number of miles driven is known, can you find the number of gallons of gas used? Explain how this value would be calculated.

*Yes, divide the number of miles driven by the constant of proportionality (31 mpg).*

- f. How many miles could be driven with 18 gallons of gas?

*558 miles*

- g. How many gallons are used when the car has been driven 18 miles?

*$\frac{18}{31}$  gallons*

- h. How many miles have been driven when half a gallon of gas is used?

*$\frac{31}{2} = 15.5$  miles*

- i. How many gallons have been used when the car has been driven for a half mile?

*$\frac{1}{62}$  gallons*

3. Suppose that the cost of renting a snowmobile is \$37.50 for 5 hours.

- a. If  $c$  represents the cost and  $h$  represents the hours, which variable is the dependent variable? Explain why.

*$c$  is the dependent variable because the cost of using the snowmobile depends on the number of hours you use it.*

$$c = 7.5h$$

- b. What would be the cost of renting 2 snowmobiles for 5 hours?

*\$75*

4. In Katya's car, the number of miles driven is proportional to the number of gallons of gas used. Find the missing value in the table.

Number of Gallons of Gas	Number of Miles Driven
0	0
4	112
6	168
8	224
10	280

- a. Write an equation that will relate the number of miles driven to the number of gallons of gas.  
 $M = 28G$ , where  $M$  is the number of miles, and  $G$  is the number of gallons of gas.
- b. What is the constant of proportionality?  
28
- c. How many miles could Katya go if she filled her 22-gallon tank?  
616 miles
- d. If Katya takes a trip of 600 miles, how many gallons of gas would be needed to make the trip?  
 $21\frac{3}{7}$  gallons
- e. If Katya drives 224 miles during one week of commuting to school and work, how many gallons of gas would she use?  
8 gallons



## Lesson 10: Interpreting Graphs of Proportional Relationships

### Student Outcomes

- Students consolidate their understanding of equations representing proportional relationships as they interpret what points on the graph of a proportional relationship mean in terms of the situation or context of the problem, including the point  $(0, 0)$ .
- Students are able to identify and interpret in context the point  $(1, r)$  on the graph of a proportional relationship where  $r$  is the unit rate.

### Classwork

#### Examples (15 minutes)

Example 1 is a review of previously taught concepts, but the lesson is built upon this example. Pose the challenge to the students to complete the table.

Have students work individually and then compare and critique each other's work with a partner.

#### Example 1

Grandma's special chocolate chip cookie recipe, which yields 4 dozen cookies, calls for 3 cups of flour. Using this information, complete the chart:

Create a table comparing the amount of flour used to the amount of cookies.

Number of Cups of Flour	Number of Dozens of Cookies
3	4
6	8
12	16

Is the number of cookies proportional to the amount of flour used? Explain why or why not.

*Yes, because there exists a constant,  $\frac{4}{3}$  or  $1\frac{1}{3}$ , such that each measure of the cups of flour multiplied by the constant gives the corresponding measure of cookies.*

What is the unit rate of cookies to flour  $\left(\frac{y}{x}\right)$ , and what is the meaning in the context of the problem?

$1\frac{1}{3}$   
 $1\frac{1}{3}$  dozen cookies, or 16 cookies for 1 cup of flour

Model the relationship on a graph.

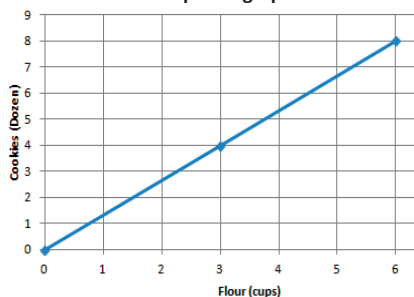

Does the graph show the two quantities being proportional to each other? Explain.

*The points appear on a line that passes through the origin  $(0, 0)$ .*

Write an equation that can be used to represent the relationship.

$D = 1\frac{1}{3}F$ ,  $D = 1.\bar{3}F$ , or  
 $D = \frac{4}{3}F$

*D represents the number of dozens of cookies.*

*F represents the number of cups of flour.*

**Example 2**

Below is a graph modeling the amount of sugar required to make Grandma's special chocolate chip cookies.

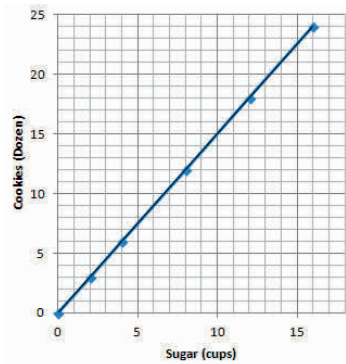

- Record the coordinates from the graph. What do these ordered pairs represent?
  - $(0, 0)$ ; 0 cups of sugar will result in 0 dozen cookies.
  - $(2, 3)$ ; 2 cups of sugar yield 3 dozen cookies.
  - $(4, 6)$ ; 4 cups of sugar yield 6 dozen cookies.
  - $(8, 12)$ ; 8 cups of sugar yield 12 dozen cookies.
  - $(12, 18)$ ; 12 cups of sugar yield 18 dozen cookies.
  - $(16, 24)$ ; 16 cups of sugar yield 24 dozen cookies.
- Grandma has 1 remaining cup of sugar. How many dozen cookies will she be able to make? Plot the point on the graph above.
  - 1.5 dozen cookies
- How many dozen cookies can Grandma make if she has no sugar? Can you graph this on the coordinate plane provided above? What do we call this point?
  - $(0, 0)$ ; 0 cups of sugar will result in 0 dozen cookies. The point is called the origin.

Generate class discussion using the following questions to lead to the conclusion that the point  $(1, r)$  must be on the graph, and discuss what it means.

- How is the unit rate of  $\frac{y}{x}$ , or in this case  $\frac{B}{A}$ , related to the graph?
  - The unit rate must be the value of the y-coordinate of the point on the graph, which has an x-coordinate of one.
- What quantity is measured along the horizontal axis?
  - The number of cups of sugar.
- When you plot the ordered pair  $(A, B)$ , what does  $A$  represent?
  - The amount of sugar, in cups, that is needed to make  $B$  dozen cookies.
- What quantity is measured along the vertical axis?
  - The amount of cookies (number of dozens).

- When you plot the point  $(A, B)$ , what does  $B$  represent?
  - *The total amount of cookies, in dozens, that can be made with  $A$  cups of sugar.*
- What is the unit rate for this proportional relationship?
  - 1.5
- Starting at the origin, if you move one unit along the horizontal axis, how far would you have to move vertically to reach the line you graphed?
  - 1.5 units
- Continue moving one unit at a time along the horizontal axis. What distance, vertically, did you move?
  - 1.5 units
- Why are we always moving 1.5 units vertically?
  - *The rate is 1.5 dozen/cup, that is, 1.5 dozen cookies for every 1 cup of sugar. The rate represents the proportional relationship  $y = (1.5)x$ , where the unit rate is 1.5. Thus, for any two points in the proportional relationship, if their  $x$ -values differ by 1 unit, then their  $y$ -values will differ by 1.5.*
- Do you think the vertical move will always be equal to the rate when moving 1 unit horizontally whenever two quantities that are proportional are graphed?
  - *Yes, the vertical distance will always be equal to the unit rate when moving one unit horizontally on the axis.*

### Exercises (20 minutes)

#### Exercises

1. The graph below shows the amount of time a person can shower with a certain amount of water.

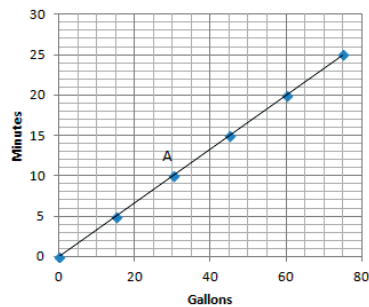

- a. Can you determine by looking at the graph whether the length of the shower is proportional to the number of gallons of water? Explain how you know.
- Yes, the quantities are proportional to each other since all points lie on a line that passes through the origin  $(0, 0)$ .*
- b. How long can a person shower with 15 gallons of water? How long can a person shower with 60 gallons of water?
- 5 minutes; 20 minutes*
- c. What are the coordinates of point  $A$ ? Describe point  $A$  in the context of the problem.
- $(30, 10)$ . If there are 30 gallons of water, then a person can shower for 10 minutes.*

- d. Can you use the graph to identify the unit rate?

*Since the graph is a line that passes through (0, 0) and (1, r), you can take a point on the graph, such as (15, 5) and get  $\frac{1}{3}$ .*

- e. Write the equation to represent the relationship between the number of gallons of water used and the length of a shower.

*$m = \frac{1}{3}g$ , where  $m$  represents the number of minutes, and  $g$  represents the number of gallons of water.*

2. Your friend uses the equation  $C = 50P$  to find the total cost,  $C$ , for the number of people,  $P$ , entering a local amusement park.

- a. Create a table and record the cost of entering the amusement park for several different-sized groups of people.

Number of People ( $P$ )	Total Cost (in dollars, $C$ )
0	0
1	50
2	100
3	150

- b. Is the cost of admission proportional to the amount of people entering the amusement park? Explain why or why not.

*Yes. The cost of admission is proportional to the amount of people entering the amusement park because there exists a constant (50), such that each measure of the amount of people multiplied by the constant gives the corresponding measures of cost.*

- c. What is the unit rate, and what does it represent in the context of the situation?

*50; 1 person costs \$50.*

- d. Sketch a graph to represent this relationship.

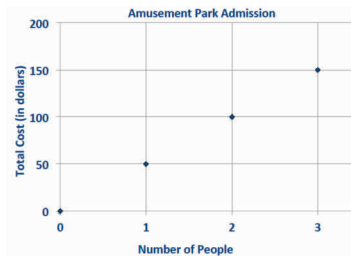

- e. What points must be on the graph of the line if the two quantities represented are proportional to each other? Explain why, and describe these points in the context of the problem.

*(0, 0) and (1, 50). If 0 people enter the park, then the cost would be \$0. If 1 person enters the park, the cost would be \$50. For every 1-unit increase along the horizontal axis, the change in the vertical distance is 50 units.*

- f. Would the point (5, 250) be on the graph? What does this point represent in the context of the situation?

*Yes, the point (5, 250) would be on the graph because  $5(50) = 250$ . The meaning is that it would cost a total of \$250 for 5 people to enter the amusement park.*

**Scaffolding:**

- Is it possible to switch the labels on the  $x$ -axis and on the  $y$ -axis?
- Can the gallons of water depend on the minutes?
- How would this change the problem?

**Closing (5 minutes)**

- What points are always on the graph of two quantities that are proportional to each other?
  - *The points  $(0,0)$  and  $(1,r)$ , where  $r$  is the unit rate, are always on the graph.*
- How can you use the unit rate of  $\frac{y}{x}$  to create a table, equation, or graph of a relationship of two quantities that are proportional to each other?
  - *In a table, you can multiply each  $x$ -value by the unit rate to obtain the corresponding  $y$ -value, or you can divide every  $y$ -value by the unit rate to obtain the corresponding  $x$ -value. You can use the equation  $y = kx$  and replace the  $k$  with the unit rate of  $\frac{y}{x}$ . In a graph, the points  $(1,r)$  and  $(0,0)$  must appear on the line of the proportional relationship.*
- How can you identify the unit rate from a table, equation, or graph?
  - *From a table, you can divide each  $y$ -value by the corresponding  $x$ -value. If the ratio  $y : x$  is equivalent for the entire table, then the value of the ratio,  $\frac{y}{x}$ , is the unit rate, and the relationship is proportional. In an equation in the form  $y = kx$ , the unit rate is the number represented by the  $k$ . If a graph of a line passes through the origin and contains the point  $(1,r)$ ,  $r$  representing the unit rate, then the relationship is proportional.*
- How do you determine the meaning of any point on a graph that represents two quantities that are proportional to each other?
  - *Any point  $(A,B)$  on a graph that represents a proportional relationship represents a number  $A$  corresponding to the  $x$ -axis or horizontal unit, and  $B$  corresponds to the  $y$ -axis or vertical unit.*

**Lesson Summary**

The points  $(0,0)$  and  $(1,r)$ , where  $r$  is the unit rate, will always appear on the line representing two quantities that are proportional to each other.

- The unit rate,  $r$ , in the point  $(1,r)$  represents the amount of vertical increase for every horizontal increase of 1 unit on the graph.
- The point  $(0,0)$  indicates that when there is zero amount of one quantity, there will also be zero amount of the second quantity.

These two points may not always be given as part of the set of data for a given real-world or mathematical situation, but they will always appear on the line that passes through the given data points.

**Exit Ticket (5 minutes)**



Name \_\_\_\_\_

Date \_\_\_\_\_

## Lesson 10: Interpreting Graphs of Proportional Relationships

### Exit Ticket

Great Rapids White Water Rafting Company rents rafts for \$125 per hour. Explain why the point  $(0, 0)$  and  $(1, 125)$  are on the graph of the relationship and what these points mean in the context of the problem.

## Exit Ticket Sample Solutions

Great Rapids White Water Rafting Company rents rafts for \$125 per hour. Explain why the point  $(0, 0)$  and  $(1, 125)$  are on the graph of the relationship and what these points mean in the context of the problem.

*Every graph of a proportional relationship must include the points  $(0, 0)$  and  $(1, r)$ . The point  $(0, 0)$  is on the graph because 0 can be multiplied by the constant to determine the corresponding value of 0. The point  $(1, 125)$  is on the graph because 125 is the unit rate. On the graph, for every 1 unit change on the horizontal axis, the vertical axis will change by 125 units. The point  $(0, 0)$  means 0 hours of renting a raft would cost \$0, and  $(1, 125)$  means 1 hour of renting the raft would cost \$125.*

## Problem Set Sample Solutions

1. The graph to the right shows the relationship of the amount of time (in seconds) to the distance (in feet) run by a jaguar.

a. What does the point  $(5, 290)$  represent in the context of the situation?

*In 5 seconds, a jaguar can run 290 feet.*

b. What does the point  $(3, 174)$  represent in the context of the situation?

*A jaguar can run 174 feet in 3 seconds.*

c. Is the distance run by the jaguar proportional to the time? Explain why or why not.

*Yes, the distance run by the jaguar is proportional to the time spent running because the graph shows a line that passes through the origin  $(0, 0)$ .*

d. Write an equation to represent the distance run by the jaguar. Explain or model your reasoning.

$$y = 58x$$

*The constant of proportionality, or unit rate of  $\frac{y}{x}$  is 58 and can be substituted into the equation  $y = kx$  in place of  $k$ .*

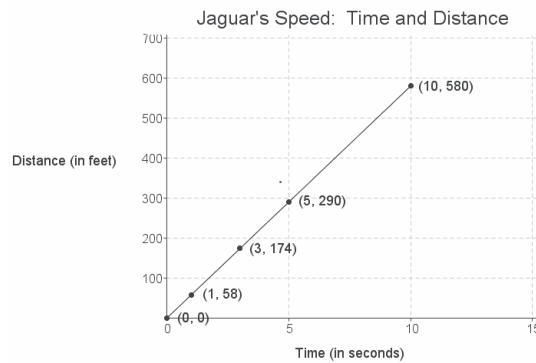

2. Championship t-shirts sell for \$22 each.

a. What point(s) must be on the graph for the quantities to be proportional to each other?

*$(0, 0)$ ,  $(1, 22)$*

b. What does the ordered pair  $(5, 110)$  represent in the context of this problem?

*5 t-shirts will cost \$110.*

- c. How many t-shirts were sold if you spent a total of \$88?

$$4; \frac{88}{22} = 4$$

3. The graph represents the total cost of renting a car. The cost of renting a car is a fixed amount each day, regardless of how many miles the car is driven.

- a. What does the ordered pair (4, 250) represent?

*It would cost \$250 to rent a car for 4 days.*

- b. What would be the cost to rent the car for a week? Explain or model your reasoning.

*Since the unit rate is 62.5, the cost for a week would be  $62.5(7) = \$437.50$ .*

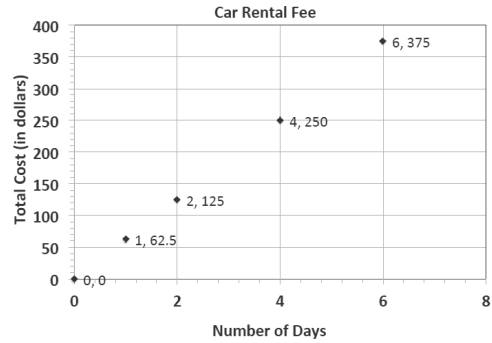

4. Jackie is making a snack mix for a party. She is using cashews and peanuts. The table below shows the relationship of the number of packages of cashews she needs to the number of cans of peanuts she needs to make the mix.

Packages of Cashews	Cans of Peanuts
0	0
1	2
2	4
3	6
4	8

- a. Write an equation to represent this relationship.

*$y = 2x$ , where  $x$  represents the number of packages of cashews, and  $y$  represents the number of cans of peanuts.*

- b. Describe the ordered pair (12, 24) in the context of the problem.

*In the mixture, you will need 12 packages of cashews and 24 cans of peanuts.*

5. The following table shows the amount of candy and price paid.

Amount of Candy (in pounds)	2	3	5
Cost (in dollars)	5	7.5	12.5

- a. Is the cost of the candy proportional to the amount of candy?

*Yes, because there exists a constant, 2.5, such that each measure of the amount of candy multiplied by the constant gives the corresponding measure of cost.*

- b. Write an equation to illustrate the relationship between the amount of candy and the cost.

$$y = 2.5x$$

- c. Using the equation, predict how much it will cost for 12 pounds of candy.

$$2.5(12) = \$30$$

- d. What is the maximum amount of candy you can buy with \$60?

$$\frac{60}{2.5} = 24 \text{ pounds}$$

- e. Graph the relationship

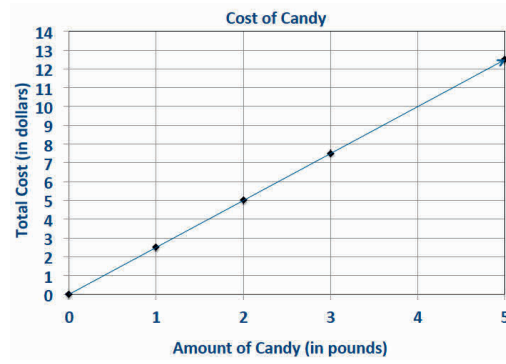



3. When a song is sold by an online music store, the store takes some of the money, and the singer gets the rest. The graph below shows how much money a pop singer makes given the total amount of money brought in by one popular online music store from sales of the song.

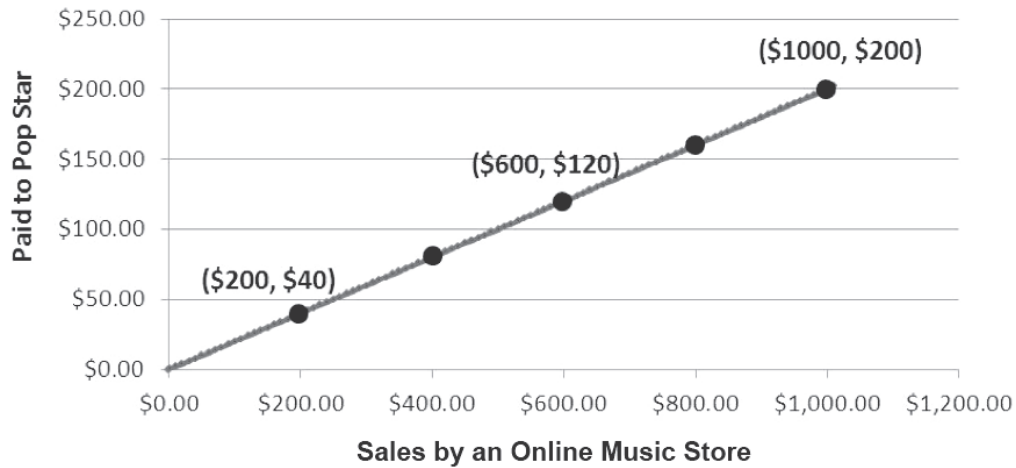

- a. Identify the constant of proportionality between dollars earned by the pop singer and dollars brought in by sales of the song.
- b. Write an equation relating dollars earned by the pop singer,  $y$ , to dollars brought in by sales of the song,  $x$ .

- c. According to the proportional relationship, how much money did the song bring in from sales in the first week if the pop star earned \$800 that week?
- d. Describe what the point  $(0,0)$  on the graph represents in terms of the situation being described by the graph.
- e. Which point on the graph represents the amount of money the pop singer gets for \$1 in money brought in from sales of the song by the store?

A Progression Toward Mastery				
Assessment Task Item	STEP 1 Missing or incorrect answer and little evidence of reasoning or application of mathematics to solve the problem.	STEP 2 Missing or incorrect answer but evidence of some reasoning or application of mathematics to solve the problem.	STEP 3 A correct answer with some evidence of reasoning or application of mathematics to solve the problem, <u>OR</u> an incorrect answer with substantial evidence of solid reasoning or application of mathematics to solve the problem.	STEP 4 A correct answer supported by substantial evidence of solid reasoning or application of mathematics to solve the problem.
1	Student answers incorrectly. Student is unable to complete at least two correct pairs of values in the table. Student is unable to respond or reason out the answer.	Student may or may not answer that the relationship is not proportional. Student is able to complete at least two correct pairs of values in the table. Student provides a limited expression of reasoning.	Student correctly answers that the relationship is not proportional. The table is correctly set up with at least two correct entries. Student's reasoning may contain a minor error.	Student correctly answers that the relationship is not proportional. Student provides correct setup and values on the table with two or more correct entries. Student reasons and demonstrates that there is no constant of proportionality or that the constant of proportionality changes for each pair of values.
2	Student answers incorrectly. Student is unable to give a complete graph or is unable to relate the proportional relationship to the graph.	Student may or may not answer that the relationship is proportional. Student provides a graph with mistakes (unlabeled axis, incorrect points). Student provides a limited expression of reasoning.	Student correctly answers that the relationship is proportional. Student labels the axes and plots points with minor errors. Student explanation is slightly incomplete.	Student correctly answers that the relationship is proportional. Student correctly labels the axes and plots the graph on the coordinate plane. Student explains that the proportional relationship is confirmed by the fact that the graph is a straight line going through the origin.



<b>3</b>	<b>a</b>	Student is unable to answer $k = \frac{1}{5}$ , and no work is shown.	Student is unable to answer $k = \frac{1}{5}$ . Concept of constant of proportionality is used incorrectly.	Student correctly answers $k = \frac{1}{5}$ but provides no work to support answer.	Student correctly answers $k = \frac{1}{5}$ . Student provides error-free work to support answer.
	<b>b</b>	Student is unable to write an equation or writes an equation that is not in the form $y = kx$ or even $x = ky$ for any value $k$ .	Student writes an incorrect equation, such as $y = 5x$ or $x = \frac{1}{5}y$ , or uses an incorrect value of $k$ from part (a) to write the equation in the form $y = kx$ .	Student creates an equation using the constant of proportionality but writes the equation in the form $x = 5y$ or some other equivalent equation.	Student correctly answers $y = \frac{1}{5}x$ .
	<b>c</b>	Student answers incorrectly and shows no or little understanding of analyzing graphs.	Student answers incorrectly but shows some understanding of analyzing graphs and solving equations.	Student answers \$4,000 in sales, but the student's work is incomplete. OR Student correctly demonstrates the steps taken to solve the equation from part (b) but makes a computational error.	Student answers \$4,000 in sales and makes no errors in the steps taken to arrive at the answer.
	<b>d</b>	Student is unable to describe the situation correctly.	Student is able to explain that the zero is the dollar amount to either the singers' earnings or sales but is unable to describe the relationship.	Student describes the situation correctly but with a minor error.	Student correctly explains that (0,0) represents the situation that zero sales leads to zero earnings for the singer.
	<b>e</b>	Student is unable to identify the $x$ - or $y$ -coordinates of the point.	Student identifies only one of the ordered pair values correctly.	Student correctly identifies the $x$ -coordinate as 1 and the $y$ -coordinate as $\frac{1}{5}$ but does not put it in an ordered pair form.	Student correctly answers $(1, \frac{1}{5})$ .

Name \_\_\_\_\_

Date \_\_\_\_\_

1. Josiah and Tillery have new jobs at Yum Yum's Ice Cream Parlor. Josiah is Tillery's manager. In their first year, Josiah will be paid \$14 per hour, and Tillery will be paid \$7 per hour. They have been told that after every year with the company, they will each be given a raise of \$2 per hour. Is the relationship between Josiah's pay and Tillery's pay rate proportional? Explain your reasoning using a table.

Year	J	T
1	14	7
2	16	9
3	18	11
4	20	13
5	22	15

NO, the relationship between Josiah's pay rate and Tillery's pay rate is not proportional because the constant of proportionality changes for each pair of numbers.

2. A recent study claimed in any given month, for every 5 text messages a boy sent or received, a girl sent or received 7 text messages. Is the relationship between the number of text messages sent or received by boys proportional to the number of text messages sent or received by girls? Explain your reasoning using a graph on the coordinate plane.

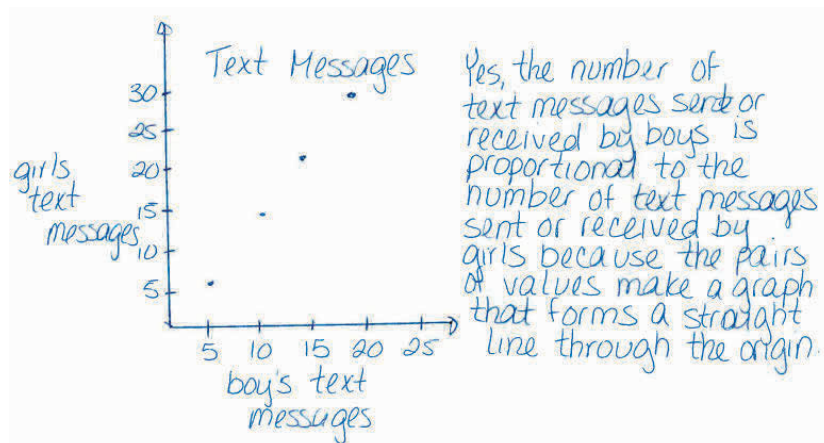

3. When a song is sold by an online music store, the store takes some of the money, and the singer gets the rest. The graph below shows how much money a pop singer makes given the total amount of money brought in by one popular online music store from sales of the song.

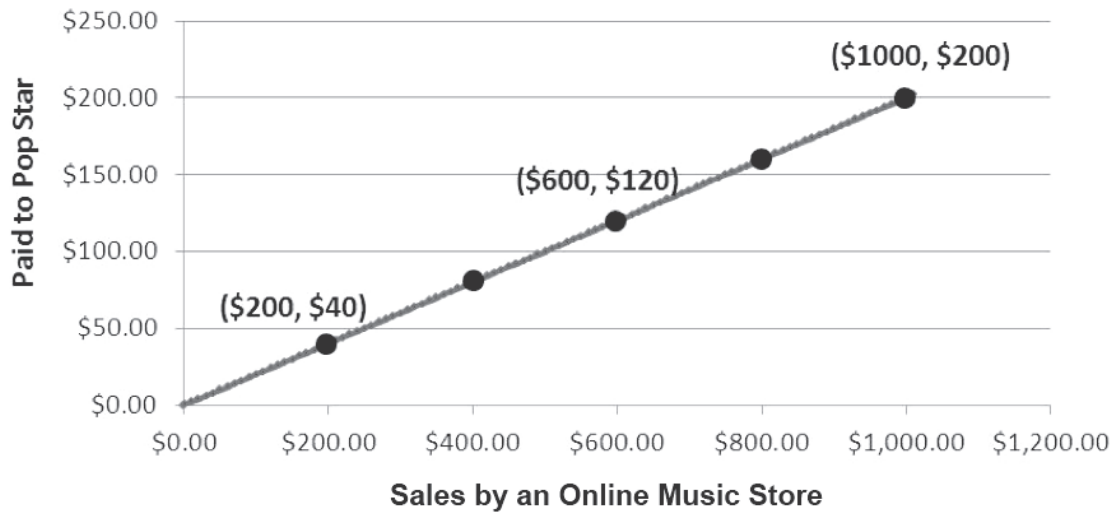

- a. Identify the constant of the proportionality between dollars earned by the pop singers and dollars brought in by sales of the song.

$$\begin{aligned} 40 &= k \\ \frac{40}{200} &= k \\ \frac{1}{5} &= k \end{aligned}$$

- b. Write an equation relating dollars earned by the pop singers,  $y$ , to dollars brought in by the sales of the song,  $x$ .

$$y = \frac{1}{5}x$$

- c. According to the proportional relationship, how much money did the song bring in from sales in the first week if the pop star earned \$800 that week?

$$\begin{array}{l} 800 = \frac{1}{5}x \\ \times \frac{5}{1} \quad \times \frac{5}{1} \\ \hline 800 \times \frac{5}{1} = x \\ 4,000 = x \end{array}$$

The sales for that week were \$4,000

- d. Describe what the point (0,0) on the graph represents in terms of the situation being described by the graph.

When the sales of the song brings in zero dollars,  
then the singer earns zero dollars.

- e. Which point on the graph represents the amount of money the pop singer gets for \$1 in money brought in from sales of the song by the store?

$$\left(1, \frac{1}{5}\right)$$



## Topic C

## Ratios and Rates Involving Fractions

- Focus Standards:**
- Compute unit rates associated with ratios of fractions, including ratios of lengths, areas and other quantities measured in like or different units. *For example, if a person walks  $\frac{1}{2}$  mile in each  $\frac{1}{4}$  hour, compute the unit rate as the complex fraction  $\frac{1/2}{1/4}$  miles per hour, equivalently 2 miles per hour.*
  - Use proportional relationships to solve multistep ratio and percent problems. *Examples: simple interest, tax, markups and markdowns, gratuities and commissions, fees, percent increase and decrease, percent error.*
  - Use variables to represent quantities in a real-world or mathematical problem, and construct simple equations and inequalities to solve problems by reasoning about the quantities.
    - Solve word problems leading to equations of the form  $px + q = r$  and  $p(x + q) = r$ , where  $p$ ,  $q$ , and  $r$  are specific rational numbers. Solve equations of these forms fluently. Compare an algebraic solution to an arithmetic solution, identifying the sequence of the operations used in each approach. For example, the perimeter of a rectangle is 54 cm. Its length is 6 cm. What is its width?

**Instructional Days:** 5

**Lessons 11–12:** Ratios of Fractions and Their Unit Rates (P, P)<sup>1</sup>

**Lesson 13:** Finding Equivalent Ratios Given the Total Quantity (P)

**Lesson 14:** Multi-Step Ratio Problems (P)

**Lesson 15:** Equations and Graphs of Proportional Relationships Involving Fractions (P)

<sup>1</sup>Lesson Structure Key: **P**-Problem Set Lesson, **M**-Modeling Cycle Lesson, **E**-Exploration Lesson, **S**-Socratic Lesson

In the first two lessons of Topic C, students' knowledge of unit rates for ratios and rates is extended by considering applications involving fractions, such as a speed of  $\frac{1}{2}$  mile per  $\frac{1}{4}$  hour. Students continue to use the structure of ratio tables to reason through and validate their computations of rate. In Lesson 13, students continue to work with ratios involving fractions as they solve problems where a ratio of two parts is given along with a desired total quantity. Students can choose a representation that most suits the problem and their comfort levels, such as tape diagrams, ratio tables, or possibly equations and graphs, as they solve these problems, reinforcing their work with rational numbers. In Lesson 14, students solve multi-step ratio problems, which include fractional markdowns, markups, commissions, and fees. In the final lesson of the topic, students focus their attention on using equations and graphs to represent proportional relationships involving fractions, reinforcing the process of interpreting the meaning of points on a graph in terms of the situation or context of the problem.



## Lesson 11: Ratios of Fractions and Their Unit Rates

### Student Outcomes

- Students use ratio tables and ratio reasoning to compute unit rates associated with ratios of fractions in the context of measured quantities such as recipes, lengths, areas, and speed.
- Students work collaboratively to solve a problem while sharing their thinking processes, strategies, and solutions with the class.

### Lesson Notes

This lesson and some future lessons require a lot of knowledge of operations with fractions and mixed numbers. During the first year of implementation, it is suggested to review both multiplication and division of fractions and mixed numbers before this lesson. Fluencies from Grade 6 can be completed before this lesson in order to review these two topics and prepare students to complete this lesson with success.

### Classwork

#### Example 1 (20 minutes): Who is Faster?

Introduce the problem statement. Allow students to use any approach to find the solution. If one (or more) of the approaches was not used, or if a student took a different approach, go through all the possible ways this problem can be solved as a class. Possible approaches are shown below, including bar models, equations, number lines, and clocks. Each approach reviews and teaches different concepts that are needed for the big picture. Starting with tables not only reinforces all of the previous material, but also reviews and addresses concepts required for the other possible approaches.

Note: Time can be represented in either hours or minutes; the solutions show both.

#### Example 1: Who is Faster?

During their last workout, Izzy ran  $2\frac{1}{4}$  miles in 15 minutes, and her friend Julia ran  $3\frac{3}{4}$  miles in 25 minutes. Each girl thought she was the faster runner. Based on their last run, which girl is correct? Use any approach to find the solution.

#### Scaffolding:

- It may be helpful to draw a clock or continually refer to a clock. Many students have difficulty telling time with the new technology available to them.
- Also, it may be helpful to do an example similar to the first example using whole numbers.

Tables:

IZZY			JULIA		
Time (minutes)	Time (hours)	Distance (miles)	Time (minutes)	Time (hours)	Distance (miles)
15	$\frac{15}{60} = \frac{1}{4}$	$2\frac{1}{4}$	25	$\frac{25}{60} = \frac{5}{12}$	$3\frac{3}{4}$
30	$\frac{30}{60} = \frac{1}{2}$	$4\frac{1}{2}$	50	$\frac{50}{60} = \frac{5}{6}$	$7\frac{1}{2}$
45	$\frac{45}{60} = \frac{3}{4}$	$6\frac{3}{4}$	75	$\frac{75}{60} = 1\frac{1}{4}$	$11\frac{1}{4}$
60	$\frac{60}{60} = 1$	9	100	$\frac{100}{60} = 1\frac{2}{3}$	15
75	$\frac{75}{60} = 1\frac{1}{4}$	$11\frac{1}{4}$			

- When looking at and comparing the tables, it appears that Julia went farther, so this would mean she ran faster. Is that assumption correct? Explain your reasoning.
  - *By creating a table of equivalent ratios for each runner showing the elapsed time and corresponding distance ran, it may be possible to find a time or a distance that is common to both tables. It can then be determined if one girl had a greater distance for a given time or if one girl had less time for a given distance. In this case, at 75 minutes, both girls ran  $11\frac{1}{4}$  miles, assuming they both ran at a constant speed.*
- How can we use the tables to determine the unit rate?
  - *Since we assumed distance is proportional to time, the unit rate or constant of proportionality can be determined by dividing the distance by the time. When the time is in hours, then the unit rate is calculated in miles per hour, which is 9. If the time is in minutes, then the unit rate is calculated in miles per minute, which is  $\frac{3}{20}$ .*
- Discuss: Some students may have chosen to calculate the unit rates for each of the girls. To calculate the unit rate for Izzy, students divided the distance ran,  $2\frac{1}{4}$ , by the elapsed time,  $\frac{15}{60}$ , which has a unit rate of 9. To find the unit rate for Julia, students divided  $3\frac{3}{4}$  by  $\frac{25}{60}$  and arrived at a unit rate of 9, as well, leading students to conclude that neither girl was faster.

Scaffolding:

Review how to divide fractions using a bar model.

- How can you divide fractions with a picture, using a bar model?
  - *Make 2 whole units and a third whole unit broken into fourths. Then, divide the whole units into fourths and count how many fourths there are in the original  $2\frac{1}{4}$  units. The answer would be 9.*

Example 1:

$$2\frac{1}{4} \div \frac{1}{4}$$

1. Green shading represents the original  $2\frac{1}{4}$  units (1<sup>st</sup> diagram).
2. Divide the whole units into  $\frac{1}{4}$  units (2<sup>nd</sup> diagram).
3. How many  $\frac{1}{4}$  units are there? 9



Example 2:

More practice with bar models, if needed:

$$1\frac{3}{4} \div \frac{1}{2}$$

1. Represent  $1\frac{3}{4}$  units (represented, here, by green shading).
2. Divide the units into groups of  $\frac{1}{2}$ .
3. The number of  $\frac{1}{2}$  units that are shaded are  $3\frac{1}{2}$ .

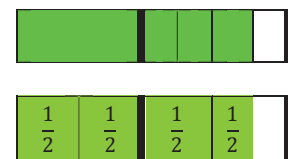



- We all agree that the girls ran at the same rate; however, some members of the class identified the unit rate as 9 while others gave a unit rate of  $\frac{3}{20}$ . How can both groups of students be correct?
  - *Time can be represented in minutes; however, in real-world contexts, most people are comfortable with distance measured by hours. It is easier for a person to visualize 9 miles per hour compared to  $\frac{3}{20}$  miles per minute, although it is an acceptable answer.*

Equations:

Izzy

$$d = rt$$

$$2\frac{1}{4} = r \cdot \frac{1}{4}$$

$$\frac{4}{1} \left[ 2\frac{1}{4} \right] = \left[ r \cdot \frac{1}{4} \right] \frac{4}{1}$$

$$9 = r$$

9 miles/hour

Julia

$$d = rt$$

$$3\frac{3}{4} = r \cdot \frac{25}{60}$$

$$\frac{60}{25} \left[ 3\frac{3}{4} \right] = \left[ r \cdot \frac{25}{60} \right] \frac{60}{25}$$

$$9 = r$$

9 miles/hour

- What assumptions are made when using the formula  $d = rt$  in this problem?
  - *We are assuming the distance is proportional to time, and that Izzy and Julia ran at a constant rate. This means they ran the same speed the entire time not slower at one point or faster at another.*

Picture:

- Some students may decide to draw a clock.
  - *Possible student explanation:*

*For Izzy, every 15 minutes of running results in a distance of  $2\frac{1}{4}$  miles. Since the clock is divided into 15-minute intervals, I added the distance for each 15-minute interval until I reached 60 minutes. Julia's rate is  $3\frac{3}{4}$  miles in 25 minutes, so I divided the clock into 25-minute intervals. Each of those 25-minute intervals represents  $3\frac{3}{4}$  miles. At 50 minutes, the distance represented is two times  $3\frac{3}{4}$  or  $7\frac{1}{2}$  miles. To determine the distance ran in the last ten minutes, I needed to determine the distance for 5 minutes:  $3\frac{3}{4} \div 5 = \frac{3}{4}$ . Therefore,  $3\frac{3}{4} + 3\frac{3}{4} + \frac{3}{4} + \frac{3}{4} = 9$ , or 9 miles per hour.*

Scaffolding:Example 3:

$$2\frac{1}{3} \div \frac{1}{6}$$

4. Represent  $2\frac{1}{3}$  units.
5. Divide into groups of  $\frac{1}{6}$ .
6. The number of  $\frac{1}{6}$  units that are shaded is 14.

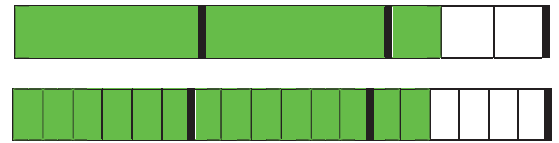

Total Distance for 1 hour

Izzy:  $2\frac{1}{4} + 2\frac{1}{4} + 2\frac{1}{4} + 2\frac{1}{4} = 9$ , 9 miles per hour

Julia:  $3\frac{3}{4} + 3\frac{3}{4} + \frac{3}{4} + \frac{3}{4} = 9$ , 9 miles per hour

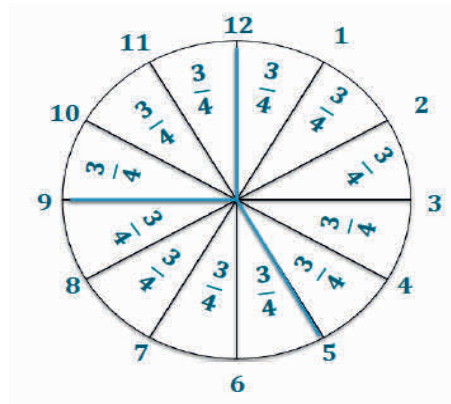
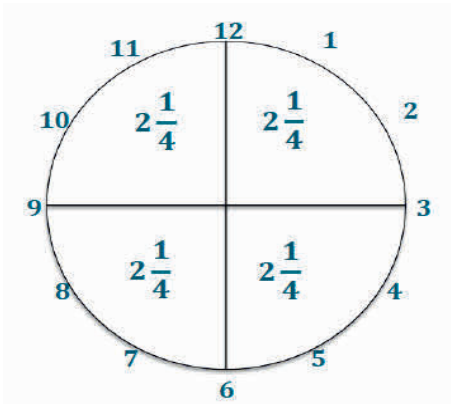

- How do you find the value of a 5-minute time increment? What are you really finding?
  - To find the value of a 5-minute increment, you need to divide  $3\frac{3}{4}$  by 5 since 25 minutes is five 5-minute increments. This is finding the unit rate for a 5-minute increment.
- Why were 5-minute time increments chosen?
  - 5-minute time increments were chosen for a few reasons. First, a clock can be separated into 5-minute intervals, so it may be easier to visualize what fractional part of an hour one has when given a 5-minute interval. Also, 5 is the greatest common factor of the two given times.
- What if the times had been 24 and 32 minutes or 18 and 22 minutes? How would this affect the time increments?
  - If the times were 24 and 32 minutes, then the time increment would be 8-minute intervals. This is because 8 is the greatest common factor of 24 and 32.
  - If the times were 18 and 22 minutes, then the comparison should be broken into 2-minute intervals since the greatest common factor of 18 and 22 is 2.

Double Number Line Approach:

Izzy

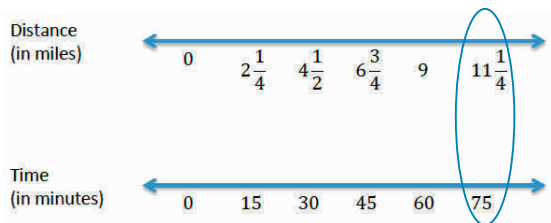

Julia

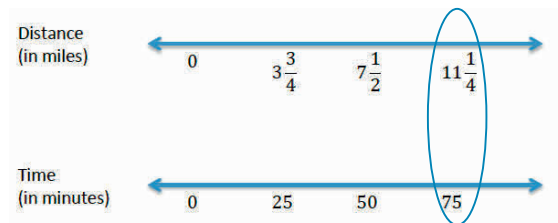

Discuss with students the double number line approach.

- Starting with Izzy, we know for every 15 minutes she runs  $2\frac{1}{4}$  miles. Therefore, we set up a number line to represent time and a second number line with the corresponding distance. The number line representing time is broken into 15-minute intervals. The distance number line is broken into intervals representing the distance at the corresponding time. For example, at 15 minutes, the distance ran is  $2\frac{1}{4}$  miles. At 30 minutes, the distance ran is  $4\frac{1}{2}$  miles. Continue to complete both number lines for Izzy.
- Following the same procedure as we did for Izzy, set up a double number line for Julia. What is different for Julia?
  - *She travels in 25-minute intervals, and for each 25-minute interval, she runs  $3\frac{3}{4}$  miles.*
- After both number lines are drawn for each runner, compare the number lines and determine the time at which the distance ran by each runner is the same.
  - *75 minutes*
- What if they did not run the same distance? How can we use the number lines to determine who is the faster runner?
  - *The faster runner will run farther in the same amount of time. Therefore, you can compare the distance ran by each runner at a common time interval.*
- For this specific example, how do we know they ran the same speed?
  - *Looking at the number lines representing time, we can see both runners distance at a common time of 75 minutes. At 75 minutes, we compare each runner's distance ran and see they both ran  $11\frac{1}{4}$  miles. Since the assumption is made that they both ran at a constant, steady rate the entire time, then we can conclude they both ran 9 miles per hour by finding the unit rate.*

### Example 2 (5 minutes): Is Meredith Correct?

This is students' first experience evaluating complex fractions. Be sure to relate the process of evaluating complex fractions to division of fractions. Please note that the solutions shown are not the only ways to solve these problems. Accept all valid solutions.

- The next example asks Meredith to determine the unit rate, expressed in miles per hour, when a turtle walks  $\frac{7}{8}$  of a mile in 50 minutes. In order to determine the unit rate, we will again divide the distance by the amount of time. We see that Meredith represented her calculation with the fraction  $\frac{\frac{7}{8}}{\frac{5}{6}}$ . This is called a complex fraction.
- A complex fraction is simply a fraction whose numerator or denominator (or both) are fractions. Who can recall what operation the fraction bar separating the numerator and denominator represents?
  - *Division*
- Therefore, Meredith is actually dividing  $\frac{7}{8}$ , the distance the turtle walked in miles, by  $\frac{5}{6}$ , the amount of time. The complex fraction represents the division problem using fewer symbols, but the operation always remains division.

**Example 2: Is Meredith Correct?**

A turtle walks  $\frac{7}{8}$  of a mile in 50 minutes. What is the unit rate when the turtle's speed is expressed in miles per hour?

- a. To find the turtle's unit rate, Meredith wrote the following complex fraction. Explain how the fraction  $\frac{5}{6}$  was obtained.

$$\frac{\left(\frac{7}{8}\right)}{\left(\frac{5}{6}\right)}$$

*To determine the unit rate, Meredith divided the distance walked by the amount of time it took the turtle. Since the unit rate is expressed in miles per hour, 50 minutes needs to be converted to hours. Since 60 minutes is equal to 1 hour, 50 minutes can be written as  $\frac{50}{60}$  hours, or  $\frac{5}{6}$  hours.*

- How can we determine the unit rate? We need a denominator of 1 hour. Right now, the denominator is  $\frac{5}{6}$  hours.
  - We can multiply  $\frac{5}{6}$  by its multiplicative inverse  $\frac{6}{5}$  to determine a denominator of 1 hour.
- Using this information, determine the unit rate in miles per hour.

- b. Determine the unit rate when the turtle's speed is expressed in miles per hour.

$$\frac{\frac{7}{8}}{\frac{5}{6}} \cdot \frac{6}{5} = \frac{42}{40} = \frac{42}{40} = \frac{21}{20}$$

The unit rate is  $\frac{21}{20}$ . The turtle's speed is  $\frac{21}{20}$  mph.

**Exercises (10 minutes)****Exercises**

1. For Anthony's birthday, his mother is making cupcakes for his 12 friends at his daycare. The recipe calls for  $3\frac{1}{3}$  cups of flour. This recipe makes  $2\frac{1}{2}$  dozen cupcakes. Anthony's mother has only 1 cup of flour. Is there enough flour for each of his friends to get a cupcake? Explain and show your work.

$$\frac{\frac{\text{cups}}{\text{dozen}}}{2\frac{1}{2}} = \frac{3\frac{1}{3}}{2\frac{1}{2}} = \frac{\frac{10}{3} \times \frac{2}{5}}{\frac{5}{2} \times \frac{2}{5}} = \frac{20}{15} = 1\frac{5}{15} = 1\frac{1}{3}$$

*No, since Anthony has 12 friends, he would need 1 dozen cupcakes. This means you need to find the unit rate. Finding the unit rate tells us how much flour his mother needs for 1 dozen cupcakes. Upon finding the unit rate, Anthony's mother would need  $1\frac{1}{3}$  cups of flour; therefore, she does not have enough flour to make cupcakes for all of his friends.*

**Scaffolding:**

For advanced learners:

Ask students to calculate the number of cupcakes his mother would be able to make with 1 cup of flour. Remind students that there are 12 items in a dozen.

2. Sally is making a painting for which she is mixing red paint and blue paint. The table below shows the different mixtures being used.

Red Paint (Quarts)	Blue Paint (Quarts)
$1\frac{1}{2}$	$2\frac{1}{2}$
$2\frac{2}{5}$	4
$3\frac{3}{4}$	$6\frac{1}{4}$
4	$6\frac{2}{3}$
1.2	2
1.8	3

- a. What is the unit rate for the values of the amount of blue paint to the amount of red paint?

$$\frac{5}{3} = 1\frac{2}{3}$$

- b. Is the amount of blue paint proportional to the amount of red paint?

*Yes. Blue paint is proportional to red paint because there exists a constant,  $\frac{5}{3} = 1\frac{2}{3}$ , such that when each amount of red paint is multiplied by the constant, the corresponding amount of blue paint is obtained.*

- c. Describe, in words, what the unit rate means in the context of this problem.

*For every  $1\frac{2}{3}$  quarts of blue paint, Sally must use 1 quart of red paint.*

### Closing (5 minutes)

- Give an example of when you might have to use a complex fraction?
- How is the unit rate calculated? Can we calculate unit rates when both values in the ratio are fractions?
- How is finding the unit rate useful?

#### Lesson Summary

A number written in fraction form whose numerator or denominator is itself a fraction is called a *complex fraction*.

If a proportional relationship is given by a description such as, "A person walks  $2\frac{1}{2}$  miles in  $1\frac{1}{4}$  hours at a constant speed," then the unit rate is

$$\frac{2\frac{1}{2}}{1\frac{1}{4}} = \frac{\frac{5}{2}}{\frac{5}{4}} = \frac{5}{2} \cdot \frac{4}{5} = 2. \text{ The person walks 2 mph.}$$

### Exit Ticket (5 minutes)

Name \_\_\_\_\_

Date \_\_\_\_\_

## Lesson 11: Ratios of Fractions and Their Unit Rates

### Exit Ticket

Which is the better buy? Show your work and explain your reasoning.

$3\frac{1}{3}$  lb. of turkey for \$10.50

$2\frac{1}{2}$  lb. of turkey for \$6.25

## Exit Ticket Sample Solutions

Which is the better buy? Show your work and explain your reasoning.

$$3\frac{1}{3} \text{ lb. of turkey for } \$10.50$$

$$2\frac{1}{2} \text{ lb. of turkey for } \$6.25$$

$$10\frac{1}{2} \div 3\frac{1}{3} = 3.15$$

$$6\frac{1}{4} \div 2\frac{1}{2} = 2.50$$

$2\frac{1}{2}$  lb. is the better buy because the price per pound is cheaper.

## Problem Set Sample Solutions

1. Determine the quotient:  $2\frac{4}{7} \div 1\frac{3}{6}$ .

$$1\frac{5}{7}$$

2. One lap around a dirt track is  $\frac{1}{3}$  mile. It takes Bryce  $\frac{1}{9}$  hour to ride one lap. What is Bryce's unit rate, in miles, around the track?

$$3$$

3. Mr. Gengel wants to make a shelf with boards that are  $1\frac{1}{3}$  feet long. If he has an 18-foot board, how many pieces can he cut from the big board?

$$13\frac{1}{2} \text{ boards}$$

4. The local bakery uses 1.75 cups of flour in each batch of cookies. The bakery used 5.25 cups of flour this morning.

- a. How many batches of cookies did the bakery make?

$$3 \text{ batches}$$

- b. If there are 5 dozen cookies in each batch, how many cookies did the bakery make?

$$5(12) = 60$$

*There are 60 cookies per batch.*

$$60(3) = 180$$

*So, the bakery made 180 cookies.*

5. Jason eats 10 ounces of candy in 5 days.

- a. How many pounds does he eat per day? (Recall: 16 ounces = 1 pound)

$$\frac{1}{8} \text{ lb. each day}$$

- b. How long will it take Jason to eat 1 pound of candy?

$$8 \text{ days}$$



## Lesson 12: Ratios of Fractions and Their Unit Rates

### Student Outcomes

- Students use ratio tables and ratio reasoning to compute unit rates associated with ratios of fractions in the context of measured quantities, such as recipes, lengths, areas, and speed.
- Students use unit rates to solve problems and analyze unit rates in the context of the problem.

### Classwork

During this lesson, you are remodeling a room at your house and need to figure out if you have enough money. You will work individually and with a partner to make a plan of what is needed to solve the problem. After your plan is complete, then you will solve the problem by determining if you have enough money.

#### Example 1 (25 minutes): Time to Remodel

Students are given the task of determining the cost of tiling a rectangular room. The students are given the dimensions of the room, the area in square feet of one tile, and the cost of one tile.

If students are unfamiliar with completing a chart like this one, guide them in completing the first row.

#### Example 1: Time to Remodel

You have decided to remodel your bathroom and install a tile floor. The bathroom is in the shape of a rectangle, and the floor measures 14 feet, 8 inches long by 5 feet, 6 inches wide. The tiles you want to use cost \$5 each, and each tile covers  $4\frac{2}{3}$  square feet. If you have \$100 to spend, do you have enough money to complete the project?

**Make a Plan:** Complete the chart to identify the necessary steps in the plan and find a solution.

What I Know	What I Want to Find	How to Find it
<i>dimensions of the floor</i>	<i>area</i>	<i>Convert inches to feet as a fraction with a denominator 12. Area = lw</i>
<i>square footage of 1 tile</i>	<i>number of tiles needed</i>	<i>total area divided by the area of 1 tile</i>
<i>cost of 1 tile</i>	<i>total cost of all tiles</i>	<i>If the total money needed is more than \$100, then I won't have enough money to do the remodel.</i>

Compare your plan with a partner. Using your plans, work together to determine how much money you will need to complete the project and if you have enough money.

**Dimensions:**      5 ft., 6 in. =  $5\frac{1}{2}$  ft.

14 ft., 8 in. =  $14\frac{2}{3}$  ft.

#### Scaffolding:

- Review that 12 inches = 1 foot and how to represent feet and inches as mixed fractions.
- Review the concept of area and the formula for finding the area of a rectangle.
- Review how to multiply mixed numbers.
- How can estimation be used to answer this problem?



**Area (square feet):**

$$A = lw$$

$$A = \left(5\frac{1}{2}\text{ ft.}\right)\left(14\frac{2}{3}\text{ ft.}\right)$$

$$A = \left(\frac{11}{2}\text{ ft.}\right)\left(\frac{44}{3}\text{ ft.}\right)$$

$$A = \frac{242}{3} = 80\frac{2}{3}\text{ ft}^2$$

**Number of Tiles:**

$$\frac{80\frac{2}{3}}{4\frac{2}{3}} = \frac{\frac{242}{3}}{\frac{14}{3}} = \frac{242}{14} = 17\frac{2}{7}$$

**I cannot buy part of a tile, so I will need to purchase 18 tiles.**

**Total Cost:**  $18(5) = \$90$

**Do I have enough money?**

**Yes. Since the total is less than \$100, I have enough money.**

Generate discussion about completing the plan and finding the solution. If needed, pose the following questions:

- Why was the mathematical concept of area, and not perimeter or volume, used?
  - *Area was used because we were “covering” the rectangular floor. Area is 2 dimensional, and we were given two dimensions, length and width of the room, to calculate the area of the floor. If we were just looking to put trim around the outside, then we would use perimeter. If we were looking to fill the room from floor to ceiling, then we would use volume.*
- Why would 5.6 inches and 14.8 inches be incorrect representations for 5 feet, 6 inches and 14 feet, 8 inches?
  - *The relationship between feet and inches is 12 inches for every 1 foot. To convert to feet, you need to figure out what fractional part 6 inches is of a foot, or 12 inches. If you just wrote 5.6, then you would be basing the inches out of 10 inches, not 12 inches. The same holds true for 14 feet, 8 inches.*
- How is the unit rate useful?
  - *The unit rate for a tile is given as  $4\frac{2}{3}$ . We can find the total number of tiles needed by dividing the area (total square footage) by the unit rate.*
- Can I buy  $17\frac{2}{7}$  tiles?
  - *No, you have to buy whole tiles and cut what you may need.*
- How would rounding to 17 tiles instead of rounding to 18 tiles affect the job?
  - *Even though the rules of rounding would say round down to 17 tiles, we would not in this problem. If we round down, then the entire floor would not be covered, and we would be short. If we round up to 18 tiles, the entire floor would be covered with a little extra.*

**Exercise (10 minutes)****Exercise**

Which car can travel farther on 1 gallon of gas?

Blue Car: travels  $18\frac{2}{5}$  miles using 0.8 gallons of gas

Red Car: travels  $17\frac{2}{5}$  miles using 0.75 gallons of gas

**Finding the Unit Rate:****Blue Car:**

$$\frac{18\frac{2}{5}}{\frac{4}{5}} = \frac{92}{5} \div \frac{4}{5} = 23$$

**Rate:**

23 miles/gallon

**Red Car:**

$$\frac{17\frac{2}{5}}{\frac{3}{4}} = \frac{87}{5} \div \frac{3}{4} = 23\frac{1}{5}$$

23 $\frac{1}{5}$  miles/gallon

The red car traveled  $\frac{1}{5}$  mile farther on one gallon of gas.

**Scaffolding:**

Since the students are at a young age, they may not be familiar with cars, distance, and miles per gallon relationships. Students may select the car with a lower unit rate because they may be confused with the better buy and lower unit prices. Further clarification may be needed to explain how a higher miles per gallon value is more favorable.

**Closing (5 minutes)**

- How can unit rates with fractions be applied in the real world?

**Exit Ticket (5 minutes)**

Name \_\_\_\_\_

Date \_\_\_\_\_

## Lesson 12: Ratios of Fractions and Their Unit Rates

### Exit Ticket

If  $3\frac{3}{4}$  lb. of candy cost \$20.25, how much would 1 lb. of candy cost?

## Exit Ticket Sample Solutions

If  $3\frac{3}{4}$  lb. of candy cost \$20.25, how much would 1 lb. of candy cost?

$$5\frac{2}{5} = 5.4$$

One pound of candy would cost \$5.40.

Students may find the unit rate by first converting \$20.25 to  $\frac{81}{4}$  and then dividing by  $\frac{15}{4}$ .

## Problem Set Sample Solutions

1. You are getting ready for a family vacation. You decide to download as many movies as possible before leaving for the road trip. If each movie takes  $1\frac{2}{5}$  hours to download, and you downloaded for  $5\frac{1}{4}$  hours, how many movies did you download?

$3\frac{3}{4}$  movies; however, since you cannot download  $\frac{3}{4}$  of a movie, then you downloaded 3 movies.

2. The area of a blackboard is  $1\frac{1}{3}$  square yards. A poster's area is  $\frac{8}{9}$  square yards. Find the unit rate and explain, in words, what the unit rate means in the context of this problem. Is there more than one unit rate that can be calculated? How do you know?

$1\frac{1}{2}$ . The area of the blackboard is  $1\frac{1}{2}$  times the area of the poster.

Yes. There is another possible unit rate:  $\frac{2}{3}$ . The area of the poster is  $\frac{2}{3}$  the area of the blackboard.

3. A toy jeep is  $12\frac{1}{2}$  inches long, while an actual jeep measures  $18\frac{3}{4}$  feet long. What is the value of the ratio of the length of the toy jeep to the length of the actual jeep? What does the ratio mean in this situation?

$$\frac{12\frac{1}{2}}{18\frac{3}{4}} = \frac{\frac{25}{2}}{\frac{75}{4}} = \frac{2}{3}$$

Every 2 inches in length on the toy jeep corresponds to 3 feet in length on the actual jeep.

4. To make 5 dinner rolls,  $\frac{1}{3}$  cup of flour is used.
- a. How much flour is needed to make one dinner roll?

$$\frac{1}{15} \text{ cup}$$

- b. How many cups of flour are needed to make 3 dozen dinner rolls?

$$2\frac{2}{5} \text{ cups}$$

- c. How many rolls can you make with  $5\frac{2}{3}$  cups of flour?

85 rolls



## Lesson 13: Finding Equivalent Ratios Given the Total

### Quantity

#### Student Outcomes

- Students use tables to find an equivalent ratio of two partial quantities given a part-to-part ratio and the total of those quantities, in the third column, including problems with ratios of fractions.

#### Classwork

##### Example 1 (12 minutes)

Have students work in pairs to complete the chart below. The teacher may allow students to utilize a calculator to assist in the multiplication step of converting mixed numbers to improper fractions.

*Scaffolding:*

Review 16 oz. = 1 lb.

##### Example 1

A group of 6 hikers are preparing for a one-week trip. All of the group's supplies will be carried by the hikers in backpacks. The leader decides that each hiker will carry a backpack that is the same fraction of weight to all of the other hikers' weights. This means that the heaviest hiker would carry the heaviest load. The table below shows the weight of each hiker and the weight of the backpack.

Complete the table. Find the missing amounts of weight by applying the same value of the ratio as the first two rows.

Hiker's Weight	Backpack Weight	Total Weight (lb.)
152 lb. 4 oz. $152\frac{1}{4}$	14 lb. 8 oz. $14\frac{1}{2}$	$166\frac{3}{4}$
107 lb. 10 oz. $107\frac{5}{8}$	10 lb. 4 oz. $10\frac{1}{4}$	$117\frac{7}{8}$
129 lb. 15 oz. $129\frac{15}{16}$	$12\frac{3}{8}$	$142\frac{5}{16}$
68 lb. 4 oz. $68\frac{1}{4}$	$6\frac{1}{2}$	$74\frac{3}{4}$
$91\frac{7}{8}$	8 lb. 12 oz. $8\frac{3}{4}$	$100\frac{5}{8}$
105	10 lb.	115

*Scaffolding:*

Review the abbreviations for pound (lb.) and ounce (oz.) if necessary.

Value of the ratio of backpack weight to hiker weight:

$$\frac{14\frac{1}{2}}{152\frac{1}{4}} = \frac{\frac{29}{2} \times 4}{\frac{609}{4} \times 4} = \frac{58}{609} = \frac{2}{21}$$

Equations:

Backpack weight (pounds):  $B$

Hiker's weight (pounds):  $H$

$$B = \frac{2}{21}H$$

$$B = \frac{2}{21} \left( 129\frac{15}{16} \right)$$

$$B = 12\frac{3}{8}$$

- What challenges did you encounter when calculating the missing values?
  - *Remembering the conversions of ounces to pounds and dividing fractions.*
- How is the third column representing the total quantity found, and how is it useful?
  - *To find the third column, you need to add the total weight of both the hiker and the backpack. The third column giving the total allows one to compare the overall quantities. Also, if the total and ratio are known, then you can find the weight of the backpack and the hiker.*
- How can you calculate the values that are placed in the third column?
  - *In order to find the third column, you need the first two columns or the ratio of the first two columns. Because the third column is the total, add the values in the first two columns.*
- If a value is missing from the first or second column, how can you calculate the value?
  - *If a value is missing from one of the first two columns, you need to look at the rest of the table to determine the constant rate or ratio. You can write an equation of the relationship and then substitute in or write an equivalent ratio of the unknown to the constant of proportionality.*
- Based on the given values and found values, is the backpack weight proportional to the hiker's weight? How do you know?
  - *The table shows the backpack weight is proportional to the hiker's weight because there exists a constant,  $\frac{2}{21}$ , that when each hiker's weight is multiplied by the constant, it results in the corresponding weight of the backpack.*
- Would these two quantities always be proportional to each other?
  - *Not necessarily. The relationship between the backpack weight and the hiker's weight will not always be in the ratio  $\frac{2}{21}$ , but for these 6 hikers it was proportional.*
- Describe how to use different approaches to find the missing values of either quantity.
  - *Writing equations or writing equivalent ratios can be used.*
- Describe the process of writing and using equations to find the missing values of a quantity.
  - *First, find the constant of proportionality or unit rate of  $\frac{y}{x}$ .*
  - *Once that is found, write an equation in the form  $y = kx$ , replacing  $k$  with the constant of proportionality.*
  - *Substitute the known value in for the variable, and solve for the unknown.*

- When writing equations to find the missing value(s) of a quantity, are we restricted to using the variables  $x$  and  $y$ ? Explain.
  - *No, any variable can be used. Often, using a variable to represent the context of the problem makes it easier to know which variable to replace with the known value. For instance, if the two quantities are hours and pay, one may use the variable  $p$  to represent pay instead of  $y$  and  $h$  to represent hours instead of  $x$ .*
- Describe the process of writing equivalent ratios to find the missing value(s) of a quantity. How is this method similar and different to writing proportions?
  - *Start with the unit rate or constant of proportionality. Determine what variable is known, and determine what you must multiply by to obtain the known value. Multiply the remaining part of the unit rate by the same number to get the value of the unknown value.*
- What must be known in order to find the missing value(s) of a quantity regardless of what method is used?
  - *The ratio of the two quantities must be known.*
- If the ratio of the two quantities and the total amount are given, can you find the remaining parts of the table?
  - *Yes, once the ratio is determined or given, find an equivalent ratio to the given ratio that also represents the total amount.*

*Scaffolding:*

May need to review solving a one-step equation using the multiplicative inverse to solve.

### Example 2 (13 minutes)

#### Example 2

When a business buys a fast food franchise, it is buying the recipes used at every restaurant with the same name. For example, all Pizzeria Specialty House Restaurants have different owners, but they must all use the same recipes for their pizza, sauce, bread, etc. You are now working at your local Pizzeria Specialty House Restaurant, and listed below are the amounts of meat used on one meat-lovers pizza.

$\frac{1}{4}$  cup of sausage

$\frac{1}{3}$  cup of pepperoni

$\frac{1}{6}$  cup of bacon

$\frac{1}{8}$  cup of ham

$\frac{1}{8}$  cup of beef

What is the total amount of toppings used on a meat-lovers pizza? 1 cup(s)

The meat must be mixed using this ratio to ensure that customers receive the same great tasting meat-lovers pizza from every Pizzeria Specialty House Restaurant nationwide. The table below shows 3 different orders for meat-lovers pizzas on the night of the professional football championship game. Using the amounts and total for one pizza given above, fill in every row and column of the table so the mixture tastes the same.

	Order 1	Order 2	Order 3
Sausage (cups)	1	$1\frac{1}{2}$	$2\frac{1}{4}$
Pepperoni (cups)	$1\frac{1}{3}$	2	3
Bacon (cups)	$\frac{2}{3}$	1	$1\frac{1}{2}$
Ham (cups)	$\frac{1}{2}$	$\frac{3}{4}$	$1\frac{1}{8}$
Beef (cups)	$\frac{1}{2}$	$\frac{3}{4}$	$1\frac{1}{8}$
<b>TOTAL (cups)</b>	<b>4</b>	<b>6</b>	<b>9</b>

- What must you calculate or know to complete this table?
  - *You need to know the amount of each kind of meat in the original recipe and then keep each type of meat in the same ratio for each order using the given information.*
- How many pizzas were made for Order 1? Explain how you obtained and used your answer.
  - *There were 4 pizzas ordered. The amount of sausage increased from  $\frac{1}{4}$  cup to 1 cup, which is 4 times as much. Knowing this, the amount of each ingredient can now be multiplied by 4 to determine how much of each ingredient is needed for Order 1.*

A bar model can be utilized as well:

- *The amount of sausage is represented by the green portion in the bar model. This represents  $\frac{1}{4}$  of a cup.*

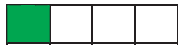

*If the amount of sausage becomes 1 cup, then the model should represent 1 whole (new green).*

*The number of  $\frac{1}{4}$ 's in one whole is 4.*

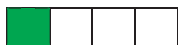

- How many pizzas were made for Order 2? Explain how you obtained and used your answer.
  - *There were 6 pizzas ordered. The amount of bacon increased from  $\frac{1}{6}$  to 1, which is 6 times as much. Each ingredient can then be multiplied by 6.*

*Bar Model:*

*The amount of bacon,  $\frac{1}{6}$ , is represented by the green portion in the model.*

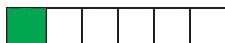



The amount of bacon became 1 cup, so the model should represent 1 whole (new green.)

The number of  $\frac{1}{6}$ 's in one whole is 6.



- How many pizzas were made for Order 3? Explain how you obtained and used your answer.
  - There were 9 pizzas ordered. The amount of pepperoni increased from  $\frac{1}{3}$  to 3, which is 9 times as much. The other ingredients can then be multiplied by 9.

Bar Model:

The number of pepperoni,  $\frac{1}{3}$ , is represented by the green portion in the model.



The amount of pepperoni becomes 3 or 3 wholes, so we need to draw 3 whole models broken in thirds. The amount of thirds in the total models is 9.

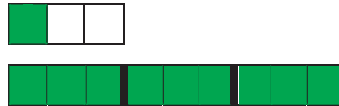

- Is it possible to order  $1\frac{1}{2}$  or  $2\frac{1}{2}$  pizzas? If so, describe the steps to determine the amount of each ingredient necessary.
  - Yes, pizzas can be sold by the half. This may not be typical, but it is possible. Most pizza places can put the ingredients on only half of a pizza. To determine the amount of each ingredient necessary, multiply the ingredient's original amount by the number of pizzas ordered.

### Exercise (12 minutes)

#### Exercise

The table below shows 6 different-sized pans that could be used to make macaroni and cheese. If the ratio of ingredients stays the same, how might the recipe be altered to account for the different-sized pans?

Noodles (cups)	Cheese (cups)	Pan Size(cups)
4	1	5
3	$\frac{3}{4}$	$3\frac{3}{4}$
1	$\frac{1}{4}$	$1\frac{1}{4}$
$\frac{2}{3}$	$\frac{1}{6}$	$\frac{5}{6}$
$5\frac{1}{3}$	$1\frac{1}{3}$	$6\frac{2}{3}$
$4\frac{1}{2}$	$1\frac{1}{8}$	$5\frac{5}{8}$

**Method 1: Equations**

Find the constant rate. To do this, use the row that gives both quantities, not the total. To find the unit rate:

$$\frac{\frac{3}{4}}{\frac{3}{3}} = \frac{3}{4} \cdot \frac{1}{3} = \frac{1}{4}$$

Write the equation of the relationship.  $c = \frac{1}{4}n$ , where  $c$  represents the cups of cheese and  $n$  represents the cups of noodles.

$$c = \frac{1}{4}n$$

$$\frac{1}{4} = \frac{1}{4}n$$

$$1 = n$$

$$c = \frac{1}{4}n$$

$$c = \frac{1}{4} \cdot \frac{2}{3}$$

$$c = \frac{1}{6}$$

$$c = \frac{1}{4}n$$

$$c = \frac{1}{4} \left( 5 \frac{1}{3} \right)$$

$$c = \frac{1}{4} \left( \frac{16}{3} \right)$$

$$c = \frac{4}{3} = 1 \frac{1}{3}$$

**Method 2: Proportions**

Find the constant rate as described in Method 1.

Set up proportions.

$y$  represents the number of cups of cheese, and  $x$  represents the number of cups of noodles.

$$\frac{\frac{1}{4}}{x} = \frac{1}{4}$$

$$x = 1$$

$$\frac{y}{\frac{2}{3}} = \frac{1}{4}$$

$$4y = \frac{2}{3}$$

$$y = \frac{\frac{2}{3}}{4}$$

$$y = \frac{2}{3} \cdot \frac{1}{4}$$

$$y = \frac{2}{12} = \frac{1}{6}$$

$$\frac{y}{5 \frac{1}{3}} = \frac{1}{4}$$

$$4y = 5 \frac{1}{3}$$

$$y = \frac{5 \frac{1}{3}}{4} = \frac{16}{3} \cdot \frac{1}{4} = \frac{4}{3}$$

**Closing (3 minutes)**

- Describe how you can calculate the missing information in a table that includes the total quantity.

**Lesson Summary**

To find missing quantities in a ratio table where a total is given, determine the unit rate from the ratio of two given quantities and use it to find the missing quantities in each equivalent ratio.

**Exit Ticket (5 minutes)**

Name \_\_\_\_\_

Date \_\_\_\_\_

## Lesson 13: Finding Equivalent Ratios Given the Total Quantity

### Exit Ticket

The table below shows the combination of a dry prepackaged mix and water to make concrete. The mix says for every 1 gallon of water stir 60 pounds of dry mix. We know that 1 gallon of water is equal to 8 pounds of water. Using the information provided in the table, complete the remaining parts of the table.

Dry Mix (pounds)	Water (pounds)	Total (pounds)
	8	
75	10	
		$14\frac{1}{6}$
$4\frac{1}{2}$		

## Exit Ticket Sample Solutions

The table below shows the combination of a dry prepackaged mix and water to make concrete. The mix says for every 1 gallon of water stir 60 pounds of dry mix. We know that 1 gallon of water is equal to 8 pounds of water. Using the information given in the table, complete the remaining parts of the table.

Dry Mix (pounds)	Water (pounds)	Total (pounds)
60	8	68
75	10	85
$12\frac{1}{2}$	$1\frac{2}{3}$	$14\frac{1}{6}$
$4\frac{1}{2}$	$\frac{3}{5}$	$5\frac{1}{10}$

## Problem Set Sample Solutions

1. Students in 6 classes, displayed below, ate the same ratio of cheese pizza slices to pepperoni pizza slices. Complete the following table, which represents the number of slices of pizza students in each class ate.

Slices of Cheese Pizza	Slices of Pepperoni Pizza	Total Slices of Pizza
2	5	7
6	15	21
8	20	28
$5\frac{1}{2}$	$13\frac{3}{4}$	$19\frac{1}{4}$
$3\frac{1}{3}$	$8\frac{1}{3}$	$11\frac{2}{3}$
$\frac{3}{5}$	$1\frac{1}{2}$	$2\frac{1}{10}$

2. To make green paint, students mixed yellow paint with blue paint. The table below shows how many yellow and blue drops from a dropper several students used to make the same shade of green paint.
- a. Complete the table.

Yellow ( $Y$ ) (mL)	Blue ( $B$ ) (mL)	Total (mL)
$3\frac{1}{2}$	$5\frac{1}{4}$	$8\frac{3}{4}$
2	3	5
$4\frac{1}{2}$	$6\frac{3}{4}$	$11\frac{1}{4}$
$6\frac{1}{2}$	$9\frac{3}{4}$	$16\frac{1}{4}$

- b. Write an equation to represent the relationship between the amount of yellow paint and blue paint.

$$B = 1.5Y$$

3. The ratio of the number of miles run to the number of miles biked is equivalent for each row in the table.
- a. Complete the table.

Distance Run (miles)	Distance Biked (miles)	Total Amount of Exercise (miles)
2	4	6
$3\frac{1}{2}$	7	$10\frac{1}{2}$
$2\frac{3}{4}$	$5\frac{1}{2}$	$8\frac{1}{4}$
$2\frac{1}{8}$	$4\frac{1}{4}$	$6\frac{3}{8}$
$1\frac{2}{3}$	$3\frac{1}{3}$	5

- b. What is the relationship between distances biked and distances run?

*The distances biked were twice as far as the distances run.*

4. The following table shows the number of cups of milk and flour that are needed to make biscuits. Complete the table.

Milk (cups)	Flour (cups)	Total (cups)
7.5	9	16.5
$8\frac{3}{4}$	10.5	$19\frac{1}{4}$
12.5	15	27.5
5	6	11



## Lesson 14: Multi-Step Ratio Problems

### Student Outcomes

- Students solve multi-step ratio problems including fractional markdowns, markups, commissions, and fees.

### Lesson Notes

In this lesson, students solve multi-step ratio problems including fractional markdowns, fractional commissions, fees, and discounts. Problems with similar context that apply percent concepts are introduced in Modules 2 and 4.

Tape diagrams are a concept that have been introduced throughout earlier grades and are used throughout Grade 7 to introduce important algebraic concepts. Although it is not required that students know how to solve each of these problems using tape diagrams, the visual modeling may help. Also, during the first year of implementation, this may be a good time to introduce tape diagrams since they can be completed side by side with algebraic thinking, and then students can use this type of model for future lessons.

### Classwork

#### Example 1 (13 minutes): Bargains

Begin this lesson by discussing advertising. Share with students that businesses create advertisements to encourage consumers to come to their businesses in order to purchase their products. Many businesses subscribe to the idea that if a consumer thinks that he or she is saving money, then the consumer is more motivated to purchase the product.

Have students verbalize how they would determine the sale prices with a discount rate of  $\frac{1}{2}$  off the original price of the shirt,  $\frac{1}{3}$  off the original price of the pants, and  $\frac{1}{4}$  off the original price of the shoes.

Students should provide an idea that is similar to this:  
discount price = original price – rate times the original price.

#### Scaffolding:

- A *consumer* is a person who buys an item.
- Remind students that *of* in mathematics is an operational word for multiply.
- Note that students may find the amount of the discount and forget to subtract it from the original price.

**Example 1: Bargains**

Peter's Pants Palace advertises the following sale: Shirts are  $\frac{1}{2}$  off the original price; pants are  $\frac{1}{3}$  off the original price; and shoes are  $\frac{1}{4}$  off the original price.

- a. If a pair of shoes costs \$40, what is the sales price?

**Method 1: Tape Diagram**



After  $\frac{1}{4}$  of the price is taken off the original price, the discounted price is \$30.

**Method 2: Subtracting  $\frac{1}{4}$  of the price from the original price**

$$\begin{aligned} 40 - \frac{1}{4}(40) \\ 40 - 10 \\ \$30 \end{aligned}$$

**Method 3: Finding the fractional part of the price being paid by subtracting  $\frac{1}{4}$  of the price from 1 whole**

$$\begin{aligned} \left(1 - \frac{1}{4}\right) 40 \\ \left(\frac{3}{4}\right) 40 \\ \$30 \end{aligned}$$

- b. At Peter's Pants Palace, a pair of pants usually sells for \$33.00. What is the sales price of Peter's pants?

**Method 1: Tape Diagram**



$$\begin{aligned} \$33 \div 3 = \$11 \\ 2(\$11) = \$22 \end{aligned}$$

**Method 2: Use the given rate of discount, multiply by the price, and then subtract from the original price.**

$$33 - \frac{1}{3}(33) = 33 - 11 = \$22$$

**Method 3: Subtract the rate from 1 whole, and then multiply that rate by the original price.**

$$\begin{aligned} 1 - \frac{1}{3} = \frac{2}{3} \\ \frac{2}{3}(33) = \$22.00 \end{aligned}$$

Use questioning to guide students to develop the methods above. Students do not need to use all three methods, but should have a working understanding of how and why they work in this problem.

**Example 2 (4 minutes): Big Al's Used Cars**

Have students generate an equation that would find the commission for the salesperson.

**Example 2: Big Al's Used Cars**

A used car salesperson receives a commission of  $\frac{1}{12}$  of the sales price of the car for each car he sells. What would the sales commission be on a car that sold for \$21,999?

$$\text{Commission} = \$21,999 \left(\frac{1}{12}\right) = \$1,833.25$$

The sales commission would be \$1,833.25 for a car sold for \$21,999.

**Example 3 (9 minutes): Tax Time****Example 3: Tax Time**

As part of a marketing plan, some businesses mark up their prices before they advertise a sales event. Some companies use this practice as a way to entice customers into the store without sacrificing their profits.

A furniture store wants to host a sales event to improve its profit margin and to reduce its tax liability before its inventory is taxed at the end of the year.

How much profit will the business make on the sale of a couch that is marked up by  $\frac{1}{3}$  and then sold at a  $\frac{1}{5}$  off discount if the original price is \$2,400?

$$\text{Markup: } \$2400 + \$2400 \left(\frac{1}{3}\right) = \$3200 \text{ or } \$2400 \left(1\frac{1}{3}\right) = \$3200$$

$$\text{Markdown: } \$3200 - \$3200 \left(\frac{1}{5}\right) = \$2560 \text{ or } \$3200 \left(\frac{4}{5}\right) = \$2560$$

$$\text{Profit} = \text{sales price} - \text{original price} = \$2560 - \$2400 = \$160.00$$

**Example 4 (9 minutes): Born to Ride**

Explain that a whole plus the fractional increase gives  $1 + \frac{1}{5} = \frac{6}{5}$  of the original price.

**Example 4: Born to Ride**

A motorcycle dealer paid a certain price for a motorcycle and marked it up by  $\frac{1}{5}$  of the price he paid. Later, he sold it for \$14,000. What is the original price?

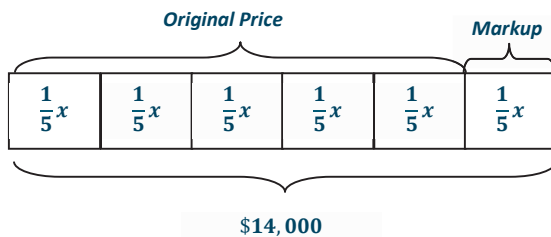

Let  $x =$  the original price

$$x + \frac{1}{5}x = 14000$$

$$\frac{6}{5}x = 14000$$

$$\left(\frac{5}{6}\right)\frac{6}{5}x = \left(\frac{5}{6}\right)14000$$

$$x = 11666.67$$

$$\begin{aligned} \frac{6}{5}x &= 14000 \\ \left(\frac{5}{6}\right)\left(\frac{6}{5}x\right) &= (14000)\left(\frac{5}{6}\right) \\ x &= 14000\left(\frac{5}{6}\right) \\ x &= 11666.67 \end{aligned}$$

The original price of the car is \$11,666.67.



**Closing (5 minutes)**

- Name at least two methods used to find the solution to a fractional markdown problem.
  - *Find the fractional part of the markdown, and subtract it from the original price.*
  - *Use a tape diagram to determine the value each part represents, and then subtract the fractional part from the whole.*
- Compare and contrast a commission and a discount price.
  - *The commission and the discount price are both fractional parts of the whole. The difference between them is that commission is found by multiplying the commission rate times the sale, while the discount is the difference between 1 and the fractional discount multiplied by the original price.*

**Exit Ticket (5 minutes)**

Name \_\_\_\_\_

Date \_\_\_\_\_

## Lesson 14: Multi-Step Ratio Problems

### Exit Ticket

- A bicycle shop advertised all mountain bikes priced at a  $\frac{1}{3}$  discount.
  - What is the amount of the discount if the bicycle originally costs \$327?
  - What is the discount price of the bicycle?
  - Explain how you found your solution to part (b).
- A hand-held digital music player was marked down by  $\frac{1}{4}$  of the original price.
  - If the sales price is \$128.00, what is the original price?
  - If the item was marked up by  $\frac{1}{2}$  before it was placed on the sales floor, what was the price that the store paid for the digital player?
  - What is the difference between the discount price and the price that the store paid for the digital player?

## Exit Ticket Sample Solutions

1. A bicycle shop advertised all mountain bikes priced at a  $\frac{1}{3}$  discount.
- a. What is the amount of the discount if the bicycle originally costs \$327?
- $$\frac{1}{3}(\$327) = \$109 \text{ discount}$$
- b. What is the discount price of the bicycle?
- $$\frac{2}{3}(\$327) = \$218 \text{ discount price. Methods will vary.}$$
- c. Explain how you found your solution to part (b).
- Answers will vary.*
2. A hand-held digital music player was marked down by  $\frac{1}{4}$  of the original price.
- a. If the sales price is \$128.00, what is the original price?
- $$x - \frac{1}{4}x = 128$$
- $$\frac{3}{4}x = 128$$
- $$x = 170.67$$
- The original price is \$170.67.*
- b. If the item was marked up by  $\frac{1}{2}$  before it was placed on the sales floor, what was the price that the store paid for the digital player?
- $$x + \frac{1}{2}x = 170.67$$
- $$\frac{3}{2}x = 170.67$$
- $$x = 113.78$$
- The price that the store paid for the digital player was \$113.78.*
- c. What is the difference between the discount price and the price that the store paid for the digital player?
- $$\$128 - \$113.78 = \$14.22$$

## Problem Set Sample Solutions

1. A salesperson will earn a commission equal to  $\frac{1}{32}$  of the total sales. What is the commission earned on sales totaling \$24,000?
- $$\left(\frac{1}{32}\right)\$24000 = \$750$$

2. DeMarkus says that a store overcharged him on the price of the video game he bought. He thought that the price was marked  $\frac{1}{4}$  of the original price, but it was really  $\frac{1}{4}$  off the original price. He misread the advertisement. If the original price of the game was \$48, what is the difference between the price that DeMarkus thought he should pay and the price that the store charged him?

$$\frac{1}{4} \text{ of } \$48 = \$12 \text{ (the price DeMarkus thought he should pay); } \frac{1}{4} \text{ off } \$48 = \$36; \text{ Difference between prices: } \\ \$36 - \$12 = \$24$$

3. What is the cost of a \$1,200 washing machine after a discount of  $\frac{1}{5}$  the original price?

$$\left(1 - \frac{1}{5}\right) \$1200 = \$960 \text{ or } \$1200 - \frac{1}{5}(\$1200) = \$960$$

4. If a store advertised a sale that gave customers a  $\frac{1}{4}$  discount, what is the fractional part of the original price that the customer will pay?

$$1 - \frac{1}{4} = \frac{3}{4} \text{ of original price}$$

5. Mark bought an electronic tablet on sale for  $\frac{1}{4}$  off the original price of \$825.00. He also wanted to use a coupon for  $\frac{1}{5}$  off the sales price. How much did Mark pay for the tablet?

$$\$825 \left(\frac{3}{4}\right) = \$618.75, \text{ then } \$618.75 \left(\frac{4}{5}\right) = \$495$$

6. A car dealer paid a certain price for a car and marked it up by  $\frac{7}{5}$  of the price he paid. Later, he sold it for \$24,000. What is the original price?

$$\begin{aligned} x + \frac{7}{5}x &= 24000 \\ \frac{12}{5}x &= 24000 \\ x &= 10000 \end{aligned}$$

The original price was \$10,000.

7. Joanna ran a mile in physical education class. After resting for one hour, her heart rate was 60 beats per minute. If her heart rate decreased by  $\frac{2}{5}$ , what was her heart rate immediately after she ran the mile?

$$\begin{aligned} x - \frac{2}{5}x &= 60 \\ \frac{3}{5}x &= 60 \\ x &= 100 \end{aligned}$$

Her heart rate was 100 beats per minute.



## Lesson 15: Equations of Graphs of Proportional Relationships Involving Fractions

### Student Outcomes

- Students use equations and graphs to represent proportional relationships arising from ratios and rates involving fractions.
- Students interpret what points on the graph of the relationship mean in terms of the situation or context of the problem.

### Classwork

Review with students the meaning of unit rate, the meaning of an ordered pair in the proportional relationship context, the meaning of  $(0, 0)$ , and the meaning of  $(1, r)$  from Lesson 10. The goal here is to help students see the relationship between the unit rate and the changes in  $x$  and  $y$ .

#### Example 1 (15 minutes): Mother's 10K Race

Use the table to determine the constant of proportionality and remind students how this was done in earlier lessons. Help students to understand what the constant of proportionality means in the context of this problem.

Discuss and model with students how to graph fractional coordinates so that the ordered pairs are as accurate as possible.

##### Example 1: Mother's 10K Race

Sam's mother has entered a 10K race. Sam and his family want to show their support for their mother, but they need to figure out where they should go along the race course. They also need to determine how long it will take her to run the race so that they will know when to meet her at the finish line. Previously, his mother ran a 5K race with a time of  $1\frac{1}{2}$  hours. Assume Sam's mother will run the same rate as the previous race in order to complete the chart.

- Discuss with your partner: Can you find Sam's mother's average rate for the entire race based on her previous race time?
  - $3\frac{1}{3}$  km/h, or  $\frac{10}{3}$  km/h

##### Scaffolding:

- A 10K race has a length of 10 kilometers (approximately 6.2 miles).
- Help students find ordered pairs from graphs that fall on coordinates that are easy to see.
- Have students use the coordinates to determine the constant of proportionality (unit rate).

Create a table that shows how far Sam's mother has run after each half hour from the start of the race, and graph it on the coordinate plane to the right.

Time ( $H$ , in hours)	Distance Run ( $D$ , in km)
$\frac{1}{2}$	$\frac{10}{3} \left(\frac{1}{2}\right) = \frac{5}{3} = 1\frac{2}{3}$
1	$\frac{10}{3}(1) = \frac{10}{3} = 3\frac{1}{3}$
$1\frac{1}{2}$	$\frac{10}{3} \left(\frac{3}{2}\right) = 5$
2	$\frac{10}{3}(2) = \frac{20}{3} = 6\frac{2}{3}$
$2\frac{1}{2}$	$\frac{10}{3} \left(\frac{5}{2}\right) = \frac{25}{3} = 8\frac{1}{3}$
3	$\frac{10}{3}(3) = 10$

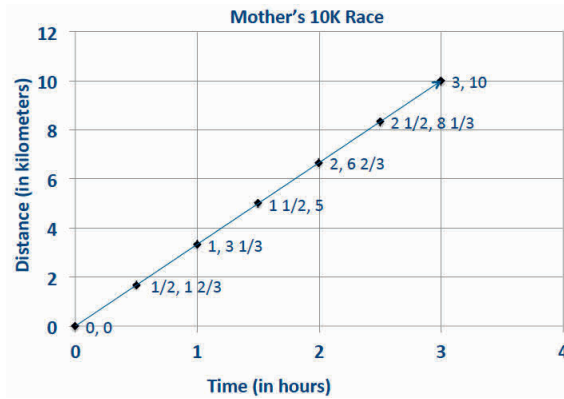

- a. What are some specific things you notice about this graph?

*It forms a line through the origin; it relates time (in hours) to the distance run (in kilometers); the line through the origin means that the values are proportional.*

- b. What is the connection between the table and the graph?

*The time (in hours) is on the horizontal axis, and the distance run (in kilometers) is on the vertical axis; the coordinates of the points on the line are the same as the pairs of numbers in the table.*

- c. What does the point  $(2, 6\frac{2}{3})$  represent in the context of this problem?

*After 2 hours, she has run  $6\frac{2}{3}$  km.*

Discuss the responses with the class and draw a conclusion.

- Write an equation that models the data in the chart. Record the student responses so that they can see all of the responses.
  - $D = 3\frac{1}{3}H$ , where  $D$  represents the distance, and  $H$  represents the hours (or  $D = \frac{10}{3}H$ ).

**Example 2 (16 minutes): Gourmet Cooking**

Students should write the equation from the data given and complete the ordered pairs in the table. Pose the questions to students as a whole group, one question at a time:

**Example 2: Gourmet Cooking**

After taking a cooking class, you decide to try out your new cooking skills by preparing a meal for your family. You have chosen a recipe that uses gourmet mushrooms as the main ingredient. Using the graph below, complete the table of values and answer the following questions.

Weight (in pounds)	Cost (in dollars)
0	0
$\frac{1}{2}$	4
1	8
$1\frac{1}{2}$	12
2	16
$2\frac{1}{4}$	18

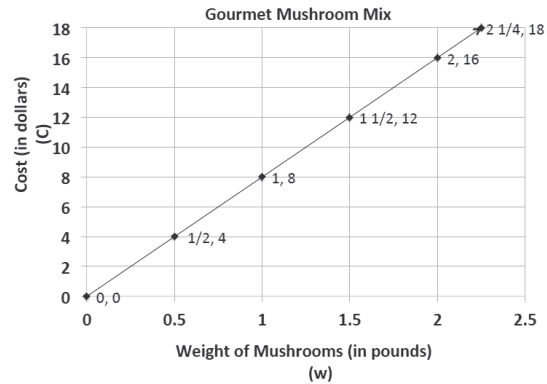

- a. Is this relationship proportional? How do you know from examining the graph?

*Yes, the relationship is proportional because the graph is a line that passes through the origin.*

- b. What is the unit rate for cost per pound?

$$k = \frac{16}{2} = 8. \text{ The unit rate is } 8.$$

- c. Write an equation to model this data.

$$C = 8w$$

- d. What ordered pair represents the unit rate, and what does it mean?

*(1, 8) The unit rate is 8, which means that one pound of mushrooms costs \$8.00.*

- e. What does the ordered pair (2, 16) mean in the context of this problem?

*(2, 16) This means 2 pounds of mushrooms cost \$16.00.*

- f. If you could spend \$10.00 on mushrooms, how many pounds could you buy?

$$C = 8w; C = 10; \left(\frac{1}{8}\right)10 = \left(\frac{1}{8}\right)8w; 1\frac{1}{4} = w. \text{ You can buy } 1.25 \text{ pounds of mushrooms with } \$10.00.$$

- g. What would be the cost of 30 pounds of mushrooms?

$$C = 8w; w = 30; C = 8(30); C = \$240$$

Have students share how they would find the cost for 3 lb., 4 oz. of mushrooms. Students convert 3 lb., 4 oz. to  $3\frac{1}{4}$  lb., and then multiply the weight by 8 to determine the cost of \$26.

Discuss the usefulness of equations as models and how they help to determine very large or very small values that are difficult or impossible to see on a graph.

Students should complete these problems in cooperative groups and then be assigned one problem per group to present in a gallery walk. As groups of students walk around the room to view the work, have them write feedback on sticky notes about presentations, clarity of explanations, etc. Students should compare their answers and have a class discussion after the walk about any solutions in which groups disagreed or found incomplete.

### Closing (7 minutes)

After the gallery walk, refer back to the graphs and charts that students presented.

- Are all graphs lines through the origin?
- Did each group write the equation that models the situation in their problem?
- Did each group find the correct constant of proportionality (unit rate) for their problem and describe its meaning in the context of the problem using appropriate units?

#### Lesson Summary

Proportional relationships can be represented through the use of graphs, tables, equations, diagrams, and verbal descriptions.

In a proportional relationship arising from ratios and rates involving fractions, *the graph* gives a visual display of *all values* of the proportional relationship, especially the quantities that fall between integer values.

### Exit Ticket (7 minutes)



Name \_\_\_\_\_

Date \_\_\_\_\_

## Lesson 15: Equations of Graphs of Proportional Relationships Involving Fractions

### Exit Ticket

Using the graph and its title:

1. Describe the relationship that the graph depicts.
2. Identify two points on the line, and explain what they mean in the context of the problem.
3. What is the unit rate?
4. What point represents the unit rate?

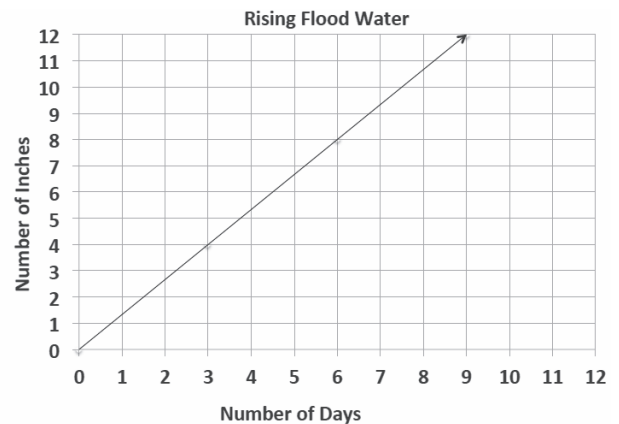

## Exit Ticket Sample Solutions

1. Describe the relationship that the graph depicts.

The graph shows that in 3 days the water rose to 4 inches. The water has risen at a constant rate. Therefore, the water has risen  $1\frac{1}{3}$  inches per day.

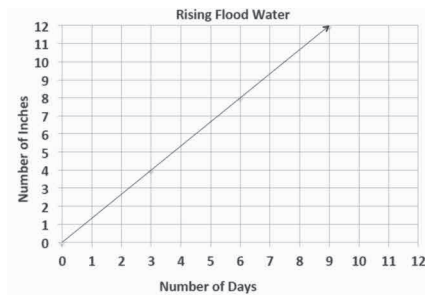

2. Identify two points on the line, and explain what they mean in the context of the problem.

$(6, 8)$  means that by the 6<sup>th</sup> day, the water rose 8 inches;  $(9, 12)$  means that by the 9<sup>th</sup> day, the water rose 12 inches.

3. What is the unit rate?

The unit rate in inches per day is  $\frac{4}{3}$ .

4. What point represents the unit rate?

The point that shows the unit rate is  $(1, 1\frac{1}{3})$ .

## Problem Set Sample Solutions

1. Students are responsible for providing snacks and drinks for the Junior Beta Club Induction Reception. Susan and Myra were asked to provide the punch for the 100 students and family members who will attend the event. The chart below will help Susan and Myra determine the proportion of cranberry juice to sparkling water needed to make the punch. Complete the chart, graph the data, and write the equation that models this proportional relationship.

Sparkling Water (S, in cups)	Cranberry Juice (C, in cups)
1	$\frac{4}{5}$
5	4
8	$6\frac{2}{5}$
12	$9\frac{3}{5}$
50	40
100	80

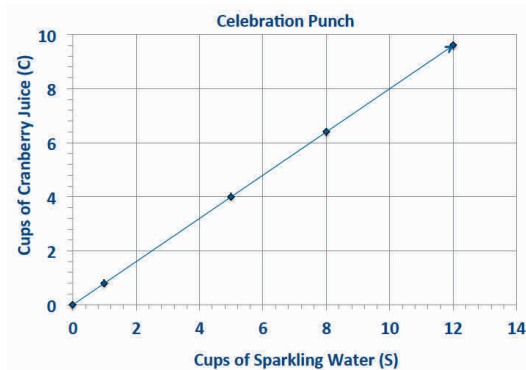

$C = \frac{4}{5}S$ , where  $C$  represents the number of cups of cranberry juice, and  $S$  represents the number of cups of sparkling water.

2. Jenny is a member of a summer swim team.

- a. Using the graph, determine how many calories she burns in one minute.

*Jenny burns 100 calories every 15 minutes, so she burns  $6\frac{2}{3}$  calories each minute.*

- b. Use the graph to determine the equation that models the number of calories Jenny burns within a certain number of minutes.

*$C = 6\frac{2}{3}t$ , where  $C$  represents the number of calories burned, and  $t$  represents the time she swims in minutes.*

- c. How long will it take her to burn off a 480-calorie smoothie that she had for breakfast?

*It will take Jenny 72 minutes of swimming to burn off the smoothie she had for breakfast.*

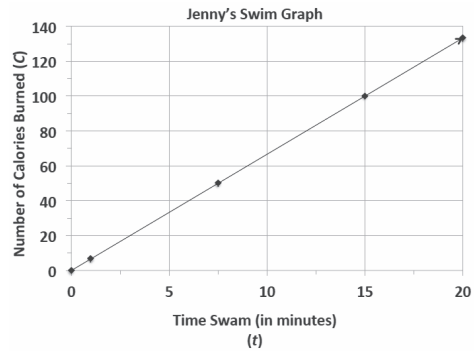

3. Students in a world geography class want to determine the distances between cities in Europe. The map gives all distances in kilometers. The students want to determine the number of miles between towns so they can compare distances with a unit of measure with which they are already familiar. The graph below shows the relationship between a given number of kilometers and the corresponding number of miles.

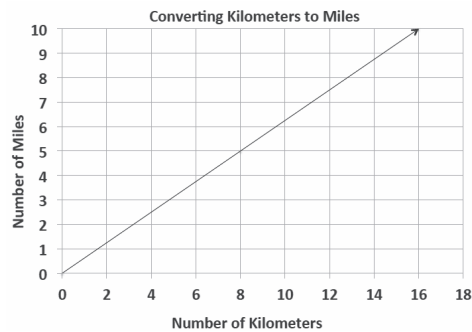

- a. Find the constant of proportionality, or the rate of miles per kilometer, for this problem, and write the equation that models this relationship.

*The constant of proportionality is  $\frac{5}{8}$ .*

*The equation that models this situation is  $M = \frac{5}{8}K$ , where  $M$  represents the number of miles, and  $K$  represents the number of kilometers.*

- b. What is the distance in kilometers between towns that are 5 miles apart?

*The distance between towns that are 5 miles apart is 8 km.*

- c. Describe the steps you would take to determine the distance in miles between two towns that are 200 kilometers apart?

*Solve the equation  $M = \frac{5}{8}(200)$ . To find the number of miles for 200 km, multiply 200 by  $\frac{5}{8}$ .*

*$200\left(\frac{5}{8}\right) = 125$ . The two towns are 125 miles apart.*

4. During summer vacation, Lydie spent time with her grandmother picking blackberries. They decided to make blackberry jam for their family. Her grandmother said that you must cook the berries until they become juice and then combine the juice with the other ingredients to make the jam.

- a. Use the table below to determine the constant of proportionality of cups of juice to cups of blackberries.

Cups of Blackberries	Cups of Juice
0	0
4	$1\frac{1}{3}$
8	$2\frac{2}{3}$
12	4
24	8

$$k = \frac{1}{3}$$

- b. Write an equation that models the relationship between the number of cups of blackberries and the number of cups of juice.

$$j = \frac{1}{3}b, \text{ where } j \text{ represents the number of cups of juice, and } b \text{ represents the number of cups of blackberries.}$$

- c. How many cups of juice were made from 12 cups of berries? How many cups of berries are needed to make 8 cups of juice?

*4 cups of juice are made from 12 cups of berries.*

*24 cups of berries are needed to make 8 cups of juice.*



## Topic D

## Ratios of Scale Drawings

- Focus Standards:**
- Recognize and represent proportional relationships between quantities.
    - Identify the constant of proportionality (unit rate) in tables, graphs, equations, diagrams, and verbal descriptions of proportional relationships.
  - Solve problems involving scale drawings of geometric figures, including computing actual lengths and areas from a scale drawing and reproducing a scale drawing at a different scale.

**Instructional Days:** 7

**Lesson 16:** Relating Scale Drawings to Ratios and Rates (E)<sup>1</sup>

**Lesson 17:** The Unit Rate as the Scale Factor (P)

**Lesson 18:** Computing Actual Lengths from a Scale Drawing (P)

**Lesson 19:** Computing Actual Areas from a Scale Drawing (P)

**Lesson 20:** An Exercise in Creating a Scale Drawing (E)

**Lessons 21–22:** An Exercise in Changing Scales (E, E)

In the first lesson of Topic D, students are introduced to scale drawings; they determine if the drawing is a reduction or enlargement of a two-dimensional picture. Pairs of figures are presented for students to match corresponding points. In Lesson 17, students learn the term *scale factor* and recognize it as the constant of proportionality. With a given scale factor, students make scale drawings of pictures or diagrams. In Lessons 18 and 19, students compute the actual dimensions of objects shown in pictures given the scale factor. They recognize that areas scale by the square of the scale factor that relates lengths. In the final lessons, students engage in their own scale factor projects—first, to produce a scale drawing of the top-view of a furnished room or building, and second, given one scale drawing, to produce a new scale drawing using a different scale factor.

---

<sup>1</sup>Lesson Structure Key: **P**-Problem Set Less, **M**-Modeling Cycle Lesson, **E**-Exploration Lesson, **S**-Socratic Lesson



## Lesson 16: Relating Scale Drawings to Ratios and Rates

### Student Outcomes

- Students understand that a scale drawing is either the reduction or the enlargement of a two-dimensional picture.
- Students compare the scale drawing picture with the original picture and determine if the scale drawing is a reduction or an enlargement.
- Students match points and figures in one picture with points and figures in the other picture.

### Classwork

#### Opening Exercise (3 minutes): Can You Guess the Image?

Project the Opening Exercise pages at the end of the lesson to show students a series of images. Determine if they can guess what is pictured and then identify whether the picture is a reduction or an enlargement of the original image. The purpose of this activity is for students to understand the terms *reduction* and *enlargement*. The scale drawings produced in Grade 7 focus on creating a scale drawing from a two-dimensional picture. Teachers can also post alternate images of choice on a projector or interactive whiteboard where only one portion is revealed. Students guess the object and determine if the picture is a reduction or an enlargement of the actual object.

Give students two minutes to guess each image in the student materials and share responses. Then show the full-size images, and have students decide whether the images in the student materials are reductions or enlargements, compared to what is now being shown.

Responses for attached images and points for discussion follow.

- This is a picture of a subway map. Was the cropped photo that was just seen a reduction or an enlargement of the original picture below? How do you know?
  - *It is a reduction since it is a scaled down picture of a map of a subway. If you compare the length from one end of a track to the other end, you can see that the cropped photo has a shorter length as compared to the original photo. Any corresponding length could be compared.*
- This is a fingerprint. Was the cropped photo that was just seen a reduction or an enlargement of the original picture below? How do you know?
  - *It is an enlargement since it was from a picture of a fingerprint. If you compare the length of one of the swirls to the actual fingerprint picture, you can see that the cropped photo has a longer length compared to the original fingerprint picture.*

#### Scaffolding:

In each Opening Exercise problem, the image can be resized on a digital display for students to see the enlarged version of the original picture.

**Opening Exercise: Can You Guess the Image?**

1. 

*This is a reduction of a subway map.*

2. 

*This is an enlarged picture of a fingerprint.*

**Example 1 (3 minutes)**



For each scale drawing, have students identify if it is a reduction or an enlargement of the actual object in real life or of the given original picture.

- What are possible uses for enlarged drawings/pictures?
  - *Enlarged drawings allow us to observe details such as textures and parts that are hard to see to the naked eye. In art, enlargements are used in murals or portraits.*
- What are the possible purposes of reduced drawings/pictures?
  - *Reductions allow us to get a general idea of a picture/object. These scale drawings can fit in folders, books, wallets, etc.*



Introduce the term *scale drawing*. Emphasize the importance of scale drawings being reductions or enlargements of two-dimensional drawings, not of actual objects.

**Example 1**

For the following problems, (a) is the actual picture, and (b) is the scale drawing. Is the scale drawing an enlargement or a reduction of the actual picture?

1. a.  b. 

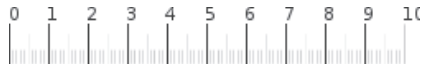
*Enlargement*

2. a.  b. 

*Reduction*

**SCALE DRAWING:** A reduced or enlarged two-dimensional drawing of an original two-dimensional drawing.

**Example 2 (7 minutes)**

Complete this activity together as a class.

- Why doesn't point  $V$  correspond with point  $R$ ?
  - *Although both points are on the bottom right hand corner, they are positioned on two different ends of the path. Point  $V$  only corresponds to Point  $W$ .*
- What must we consider before identifying corresponding points?
  - *We have to make sure we are looking at the maps in the same direction. Then we can see that this is a one-to-one correspondence because they are scale drawings of each other, and each point corresponds to one specific point on the other map.*

**Example 2**

Derek's family took a day trip to a modern public garden. Derek looked at his map of the park that was a reduction of the map located at the garden entrance. The dots represent the placement of rare plants. The diagram below is the top-view as Derek held his map while looking at the posted map.

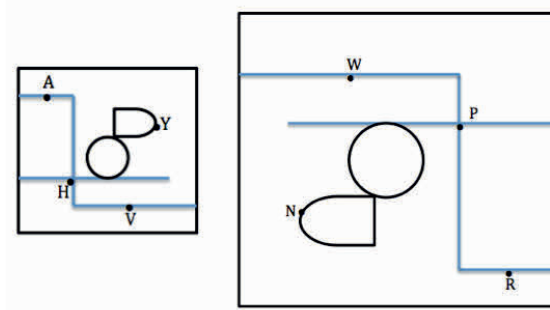

What are the corresponding points of the scale drawings of the maps?

Point  $A$  to Point  $R$  Point  $V$  to Point  $W$  Point  $H$  to Point  $P$  Point  $Y$  to Point  $N$

**Exploratory Challenge (10 minutes)**

In this exercise, the sizes of the units on the grid are enlarged, and then reduced to produce two different scale drawings with lengths that are proportional to one another. Guide students to notice that the number of units of length is staying the same, but the size of each unit changes from one drawing to another due to the shrinking and enlarging of the grid. This allows for students to create a scale drawing without having to complete the computation required in finding equivalent ratios (which is done later in Topic D).

- How will we make the enlarged robot? Will we need to adjust the number of units?
  - *No, since the grid is enlarged (thus changing the size of each unit), we can draw the new robot using the same number of units for each given length.*
- What is the importance of matching corresponding points and figures from the actual picture to the scale drawing?
  - *If there is no correspondence between points from the actual picture to the scale drawing, the scale drawing will not be proportional, and the picture will be distorted.*
- How can you check the accuracy of the proportions?
  - *You can count the squares and check that the points match.*



**Exploratory Challenge**

Create scale drawings of your own modern nesting robots using the grids provided.

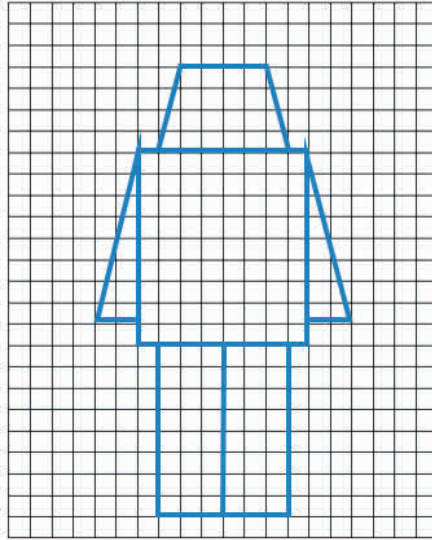
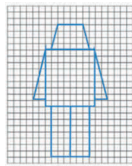
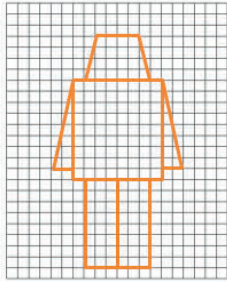
**Example 3 (7 minutes)**

Work on the problem as a class and fill in the table together. Discuss as students record important points in the “Notes” section:

- Is the second image a reduction or an enlargement of the first image? How do you know?
  - *It is a reduction because the second image is smaller than the first original image.*
- What do you notice about the information on the table?
  - *The pairs of corresponding lengths are all proportional.*
- Does a constant of proportionality exist? How do you know?
  - *Yes, it does because there is a constant value to get from each length to its corresponding length.*
- What is the constant of proportionality, and why is it important in scale drawings?
  - *The constant of proportionality is  $\frac{1}{2}$ , and it needs to exist for images to be considered scale drawings. If not, then there would be a lack of proportionality, and the images would not be a scaled up or down version of the original image.*

**Example 3**

Celeste drew an outline of a building for a diagram she was making and then drew a second one mimicking her original drawing. State the coordinates of the vertices and fill in the table.

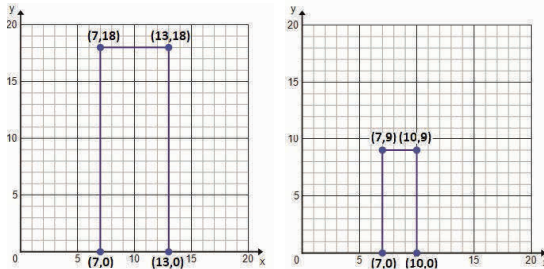

	Height	Length
Original Drawing	18 units	6 units
Second Drawing	9 units	3 units

Notes:

**Exercise (7 minutes)**

Have students work in pairs to fill out the table and answer the questions. Direct students to the vertical and horizontal lengths of the legs. Reconvene as a class to discuss answers to the given questions and the following:

- Why is it difficult to determine if the second image is a reduction or an enlargement of the first image?
  - *The second image is not a scale drawing of the first image. Although the second image is bigger, it is not a true reduction or enlargement of the first image.*
- What must one check before determining if one image is a scale drawing of another?
  - *The corresponding lengths must all be proportional to each other. If only one pair is proportional and another is not, then the images cannot be identified as scale drawings of one another.*

**Exercise**

Luca drew and cut out a small right triangle for a mosaic piece he was creating for art class. His mother liked the mosaic piece and asked if he could create a larger one for their living room. Luca made a second template for his triangle pieces.

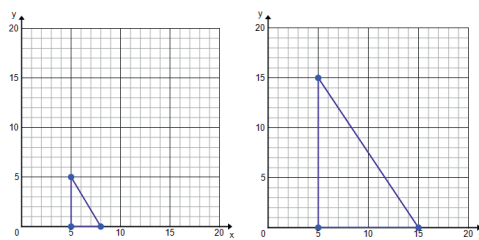

	Height	Width
Original Image	5 units	3 units
Second Image	15 units	10 units

- a. Does a constant of proportionality exist? If so, what is it? If not, explain.  
*No, because the ratios of corresponding side lengths are not equal or proportional to each other.*
- b. Is Luca's enlarged mosaic a scale drawing of the first image? Explain why or why not.  
*No, the enlarged mosaic image is not a scale drawing of the first image. We know this because the images do not have all side lengths proportional to each other; there is no constant of proportionality.*

**Closing (3 minutes)**

- What is a scale drawing?
  - *It is a drawing that is a reduction or an enlargement of an actual picture.*
- What is an enlargement? What is a reduction?
  - *An enlargement is a drawing that is larger in scale than its original picture. A reduction is a drawing that is smaller in scale than its original picture.*
- What is the importance of matching points and figures from one picture or drawing to the next?
  - *The corresponding lines, points, and figures need to match because otherwise the scale drawing will be distorted and not proportional throughout.*
- How do scale drawings relate to rates and ratios?
  - *The corresponding lengths between scale drawings and original images are equivalent ratios.*

**Lesson Summary**

**SCALE DRAWING AND SCALE FACTOR (description):** For two figures in the plane,  $S$  and  $S'$ ,  $S'$  is said to be a *scale drawing* of  $S$  with *scale factor*  $r$  if there is a one-to-one correspondence between  $S$  and  $S'$  so that, under the pairing of this one-to-one correspondence, the distance  $|PQ|$  between any two points  $P$  and  $Q$  of  $S$  is related to the distance  $|P'Q'|$  between corresponding points  $P'$  and  $Q'$  of  $S'$  by  $|P'Q'| = r|PQ|$ .

A scale drawing is an *enlargement* or *magnification* of another figure if the scale drawing is larger than the original drawing, that is, if  $r > 1$ .

A scale drawing is a *reduction* of another figure if the scale drawing is smaller than the original drawing, that is, if  $0 < r < 1$ .

**Exit Ticket (5 minutes)**

Name \_\_\_\_\_

Date \_\_\_\_\_

## Lesson 16: Relating Scale Drawings to Ratios and Rates

### Exit Ticket

Use the following figure on the graph for Problems 1 and 2.

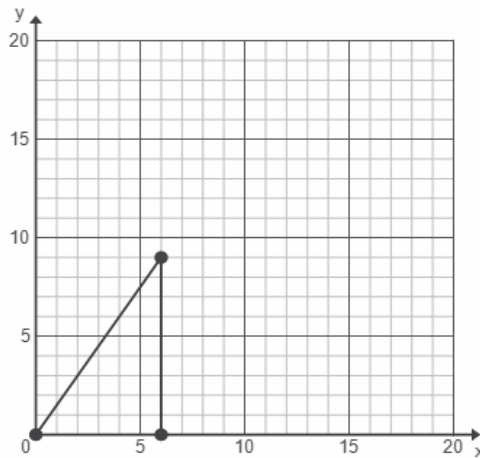

1.
  - a. If the original lengths are multiplied by 2, what are the new coordinates?
  - b. Use the table to organize lengths (the vertical and horizontal legs).

	Width	Height
<b>Actual Picture (in units)</b>		
<b>New Picture (in units)</b>		

- c. Is the new picture a reduction or an enlargement?
- d. What is the constant of proportionality?

2.

a. If the original lengths are multiplied by  $\frac{1}{3}$ , what are the new coordinates?

b. Use the table to organize lengths (the vertical and horizontal legs).

	Width	Height
Actual Picture (in units)		
New Picture (in units)		

c. Is the new picture a reduction or an enlargement?

d. What is the constant of proportionality?

## Exit Ticket Sample Solutions

Use the following figure on the graph for Problems 1 and 2.

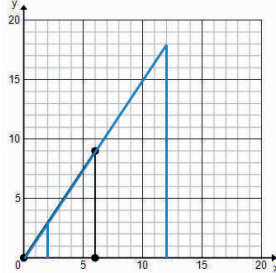

1.

- a. If the original lengths are multiplied by 2, what are the new coordinates?

$(0, 0)$ ,  $(12, 18)$ ,  $(12, 0)$

- b. Use the table to organize lengths (the vertical and horizontal legs).

	Width	Height
Actual Picture (in units)	6 units	9 units
New Picture (in units)	12 units	18 units

- c. Is the new drawing a reduction or an enlargement?

*Enlargement*

- d. What is the constant of proportionality?

2

2.

- a. If the original lengths are multiplied by  $\frac{1}{3}$ , what are the new coordinates?

$(0, 0)$ ,  $(2, 3)$ ,  $(2, 0)$

- b. Use the table to organize lengths (the vertical and horizontal legs).

	Width	Height
Actual Picture (in units)	6 units	9 units
New Picture (in units)	2 units	3 units

- c. Is the new drawing a reduction or an enlargement?

*Reduction*

- d. What is the constant of proportionality?

$\frac{1}{3}$

## Problem Set Sample Solutions

For Problems 1–3, identify if the scale drawing is a reduction or an enlargement of the actual picture.

1. Enlargement

a. Actual Picture



b. Scale Drawing

2. Reduction

a. Actual Picture

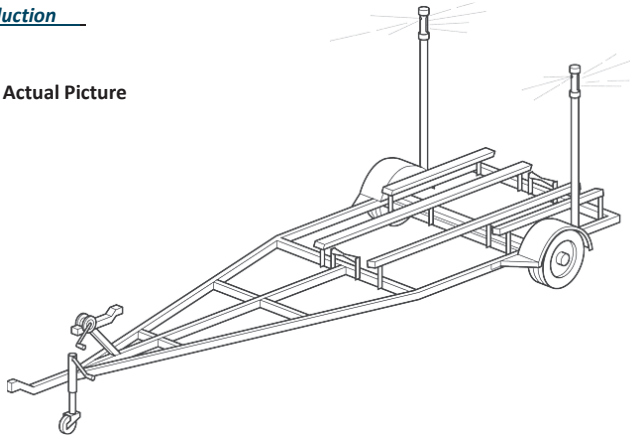

b. Scale Drawing

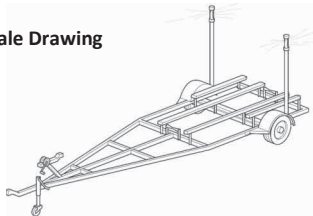
3. Enlargement

a. Actual Picture



b. Scale Drawing



4. Using the grid and the abstract picture of a face, answer the following questions:

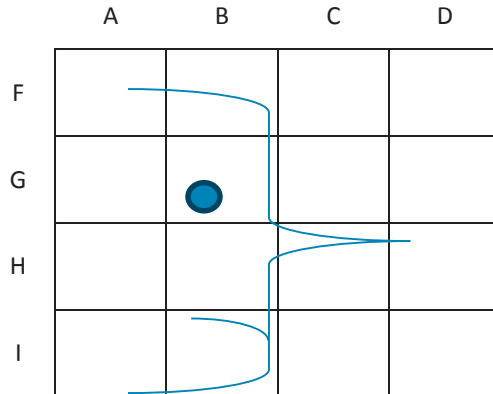

- a. On the grid, where is the eye?  
*Intersection BG*
- b. What is located in *DH*?  
*Tip of the nose*
- c. In what part of the square *BI* is the chin located?  
*Bottom right corner*

5. Use the blank graph provided to plot the points and decide if the rectangular cakes are scale drawings of each other.

Cake 1: (5, 3), (5, 5), (11, 3), (11, 5)

Cake 2: (1, 6), (1, 12), (13, 12), (13, 6)

How do you know?

*These images are not scale drawings of each other because the short length of Cake 2 is three times longer than Cake 1, but the longer length of Cake 2 is only twice as long as Cake 1. Both should either be twice as long or three times as long to have one-to-one correspondence and to be scale drawings of each other.*

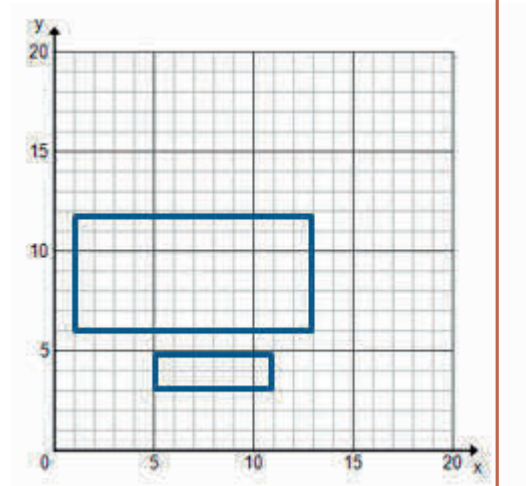



**Opening Exercise**

Can you guess the image? In each problem, the first image is from the student materials, and the second image is the actual picture.

1.



2.





## Lesson 17: The Unit Rate as the Scale Factor

### Student Outcomes

- Students recognize that the enlarged or reduced distances in a scale drawing are proportional to the corresponding distances in the original picture.
- Students recognize the scale factor to be the constant of proportionality.
- Given a picture or description of geometric figures, students make a scale drawing with a given scale factor.

### Classwork

#### Example 1 (7 minutes): Jake's Icon

After reading the prompt with the class, discuss the following questions:

- What type of scale drawing is the sticker?
  - It is an enlargement or a magnification of the original sketch.*
- What is the importance of proportionality for Jake?
  - If the image is not proportional, it looks less professional. The image on the sticker will be distorted.*
- How could we go about checking for proportionality of these two images? (Have students record steps in their student materials.)
  - Measure corresponding lengths and check to see if they all have the same constant of proportionality.*

#### Scaffolding:

- Give the measurements of the original image lengths for the table prior to beginning Example 1.
- Challenge students by giving problems that use different units of measurement and have them compare the scale factors.

As a class, label points correspondingly on the original sketch, and then on the sticker sketch. Use inches to measure the distance between the points and record on a table.

#### Example 1: Jake's Icon

Jake created a simple game on his computer and shared it with his friends to play. They were instantly hooked, and the popularity of his game spread so quickly that Jake wanted to create a distinctive icon so that players could easily identify his game. He drew a simple sketch. From the sketch, he created stickers to promote his game, but Jake wasn't quite sure if the stickers were proportional to his original sketch.

#### Original Sketch:

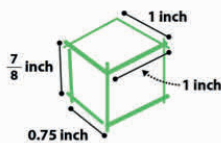

#### Sticker:

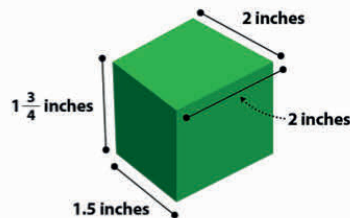

Original	Sticker
1 in.	2 in.
$\frac{3}{4}$ in.	$1\frac{1}{2}$ in.
1 in.	2 in.
$\frac{7}{8}$ in.	$1\frac{3}{4}$ in.

Steps to check for proportionality for scale drawing and original object or picture:

1. *Record the lengths of the scale drawing on the table.*
2. *Record the corresponding lengths on the actual object or picture on the table.*
3. *Check for the constant of proportionality.*

Key Idea:

The *scale factor* can be calculated from the ratio of any length in the scale drawing to its corresponding length in the actual picture. The scale factor corresponds to the unit rate and the constant of proportionality.

Scaling by factors *greater than 1* enlarges the segment, and scaling by factors *less than 1* reduces the segment.

- What relationship do you see between the measurements?
  - *The corresponding lengths are proportional.*
- Is the sticker proportional to the original sketch?
  - *Yes, the sticker lengths are twice as long as the lengths in the original sketch.*
- How do you know?
  - *The unit rate, 2, is the same for the corresponding measurements.*
- What is this called?
  - *Constant of proportionality*

Introduce the term *scale factor* and review the key idea box with students.

- Is the new figure larger or smaller than the original?
  - *Larger*
- What is the scale factor for the sticker? How do you know?
  - *The scale factor is two because the scale factor is the same as the constant of proportionality. It is the ratio of a length in the scale drawing to the corresponding length in the actual picture, which is 2 to 1. The enlargement is represented by a number greater than 1.*
- Each of the corresponding lengths is how many times larger?
  - *Two times*
- What can you predict about an image that has a scale factor of 3?
  - *The lengths of the scaled image will be three times as long as the lengths of the original image.*

### Exercise 1 (5 minutes): App Icon

Give students time to work with partners to record the lengths (in inches) of the app icon that correspond to the lengths in Example 1 on tables.

- What was the relationship between the sticker and the original sketch?
  - *The sticker is larger than the original.*

- What was the constant of proportionality, or scale factor, for this relationship?
  - 2
- What is the relationship between the icon and the original sketch?
  - *The icon is smaller than the original sketch.*
- What was the constant of proportionality, or scale factor, for this relationship?
  - $\frac{1}{2}$
- How do we determine the scale factor?
  - *Measure the lengths of the app icon and the corresponding lengths of the original sketch and record the data. Using the data, determine the constant of proportionality.*
- What does the scale factor indicate?
  - *A scale factor less than 1 indicates a reduction from the original picture, and a scale factor greater than 1 indicates a magnification or enlargement from the original picture.*

**Exercise 1: App Icon**

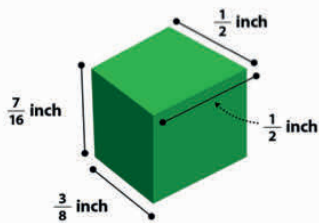

Original	App Icon
1 in.	$\frac{1}{2}$ in.
$\frac{3}{4}$ in.	$\frac{3}{8}$ in.
1 in.	$\frac{1}{2}$ in.
$\frac{7}{8}$ in.	$\frac{7}{16}$ in.

### Example 2 (7 minutes)

Begin this example by giving the scale factor, 3. Demonstrate how to make a scale drawing using the scale factor. Use a table or an equation to show how you computed your actual lengths. Note that the original image of the flag should be 1 inch by  $1\frac{1}{2}$  inches.

- Is this a reduction or an enlargement?
  - *An enlargement*
- How could you determine that it was an enlargement even before seeing the drawing?
  - *A scale factor greater than one represents an enlargement.*
- Can you predict what the lengths of the scale drawing will be?
  - *Yes, they will be 3 times as large as the actual picture.*
- What steps were used to create this scale drawing?
  - *Measure lengths of the original drawing and record onto a table. Multiply by 3 to compute the scale drawing lengths. Record and draw.*
- How can you double check your work?
  - *Divide the scale lengths by 3 to see if they match actual lengths.*

**Example 2**

Use a scale factor of 3 to create a scale drawing of the picture below.

Picture of the flag of Colombia:

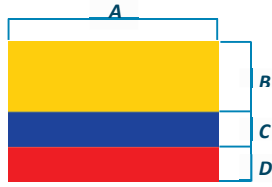

A.  $1\frac{1}{2}\text{ in.} \times 3 = 4\frac{1}{2}\text{ in.}$

B.  $\frac{1}{2}\text{ in.} \times 3 = 1\frac{1}{2}\text{ in.}$

C.  $\frac{1}{4}\text{ in.} \times 3 = \frac{3}{4}\text{ in.}$

D.  $\frac{1}{4}\text{ in.} \times 3 = \frac{3}{4}\text{ in.}$

**Exercise 2 (6 minutes)**

Have students work with partners to create a scale drawing of the original picture of the flag from Example 2 but now applying a scale factor of  $\frac{1}{2}$ .

- Is this a reduction or an enlargement?
  - *This is a reduction because the scale factor is less than one.*
- What steps were used to create this scale drawing?
  - *Compute the scale drawing lengths by multiplying by  $\frac{1}{2}$  or dividing by 2. Record. Measure the new segments with a ruler and draw.*

**Exercise 2**

Scale Factor =  $\frac{1}{2}$

Picture of the flag of Colombia:



Sketch and notes:

A.  $1\frac{1}{2}\text{ in.} \times \frac{1}{2} = \frac{3}{4}\text{ in.}$

B.  $\frac{1}{2}\text{ in.} \times \frac{1}{2} = \frac{1}{4}\text{ in.}$

C.  $\frac{1}{4}\text{ in.} \times \frac{1}{2} = \frac{1}{8}\text{ in.}$

D.  $\frac{1}{4}\text{ in.} \times \frac{1}{2} = \frac{1}{8}\text{ in.}$



**Example 3 (5 minutes)**

After reading the prompt with the class, discuss the following questions:

- What is the shape of the portrait?
  - *Square*
- Will the resulting picture be a reduction or a magnification?
  - *It will be a reduction because the phone picture is smaller than the original portrait. Also, the scale factor is less than one, so this indicates a reduction.*
- One student calculated the length to be 2 inches, while another student's response was  $\frac{1}{6}$  of a foot. Which answer is more reasonable?
  - *Although both students are correct, 2 inches is more reasonable for the purpose of measuring and drawing.*
- What will the scale drawing look like?
  - *The scale drawing should be a square measuring 2 inches by 2 inches.*

**Example 3**

Your family recently had a family portrait taken. Your aunt asks you to take a picture of the portrait using your phone and send it to her. If the original portrait is 3 feet by 3 feet, and the scale factor is  $\frac{1}{18}$ , draw the scale drawing that would be the size of the portrait on your phone.

Sketch and notes:

$$3 \times 12 \text{ in.} = 36 \text{ in.}$$

$$36 \text{ in.} \times \frac{1}{18} = 2 \text{ in.}$$

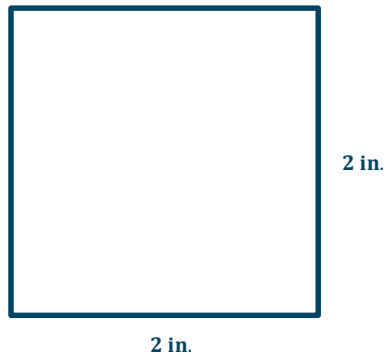
**Exercise 3 (5 minutes)**

Read the problem aloud, and ask students to solve the problem with another student.

- What is the diameter of the window in the sketch of the model house?
  - *2 inches*

**Exercise 3**

John is building his daughter a doll house that is a miniature model of their house. The front of their house has a circular window with a diameter of 5 feet. If the scale factor for the model house is  $\frac{1}{30}$ , make a sketch of the circular doll house window.

$$5 \times 12 \text{ in.} = 60 \text{ in.}$$

$$60 \text{ in.} \times \frac{1}{30} = 2 \text{ in.}$$

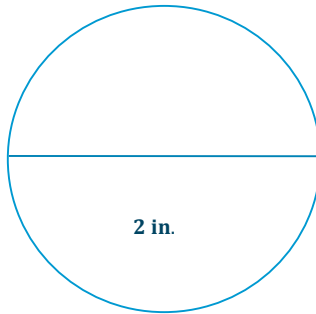
**Closing (5 minutes)**

- How is the constant of proportionality represented in scale drawings?
  - *Scale factor*
- Explain how to calculate scale factor.
  - *Measure the actual picture lengths and the scale drawing lengths. Write the values as a ratio of the length of the scale drawing length to the length of the actual picture.*
- What operation(s) is (are) used to create scale drawings?
  - *After the lengths of the actual picture are measured and recorded, multiply each length by the scale factor to find the corresponding scale drawing lengths. Measure and draw.*

**Exit Ticket (5 minutes)**



Name \_\_\_\_\_

Date \_\_\_\_\_

## Lesson 17: The Unit Rate as the Scale Factor

### Exit Ticket

A rectangular pool in your friend's yard is 150 ft.  $\times$  400 ft. Create a scale drawing with a scale factor of  $\frac{1}{600}$ . Use a table or an equation to show how you computed the scale drawing lengths.

## Exit Ticket Sample Solutions

A rectangular pool in your friend's yard is 150 ft.  $\times$  400 ft. Create a scale drawing with a scale factor of  $\frac{1}{600}$ . Use a table or an equation to show how you computed the scale drawing lengths.

Actual Length	Scale Length
150 ft.	150 ft. multiplied by $\frac{1}{600} = \frac{1}{4}$ ft., or 3 in.
400 ft.	400 ft. multiplied by $\frac{1}{600} = \frac{2}{3}$ ft., or 8 in.

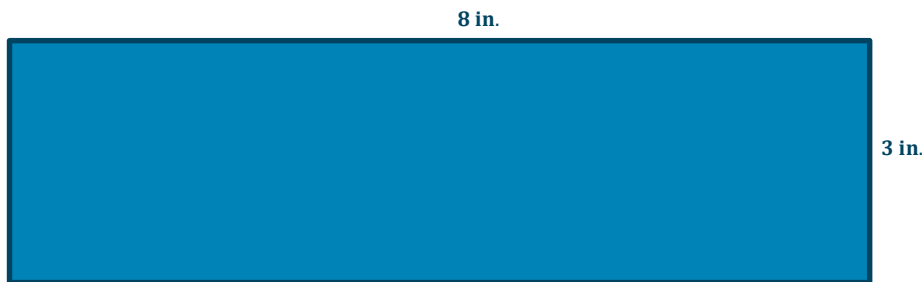

## Problem Set Sample Solutions

1. Giovanni went to Los Angeles, California, for the summer to visit his cousins. He used a map of bus routes to get from the airport to his cousin's house. The distance from the airport to his cousin's house is 56 km. On his map, the distance was 4 cm. What is the scale factor?

*The scale factor is  $\frac{1}{1,400,000}$ . I had to change kilometers to centimeters or centimeters to kilometers or both to meters in order to determine the scale factor.*

2. Nicole is running for school president. Her best friend designed her campaign poster, which measured 3 feet by 2 feet. Nicole liked the poster so much, she reproduced the artwork on rectangular buttons that measured 2 inches by  $1\frac{1}{3}$  inches. What is the scale factor?

*The scale factor is  $\frac{1}{18}$ .*

3. Find the scale factor using the given scale drawings and measurements below.

Scale Factor:  $\frac{5}{3}$

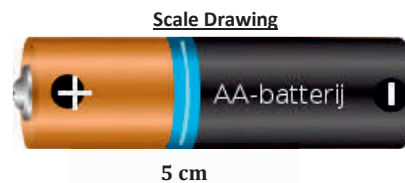
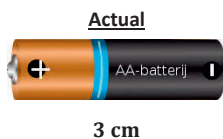

4. Find the scale factor using the given scale drawings and measurements below.

Scale Factor:  $\frac{1}{2}$  **\*\*Compare diameter to diameter or radius to radius.**

Actual Picture

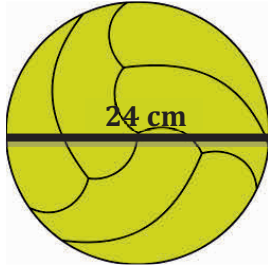

Scale Drawing

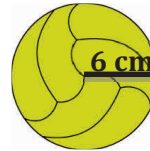

5. Using the given scale factor, create a scale drawing from the actual pictures in centimeters:

- a. Scale factor: 3

*Small Picture* : 1 in.

*Large Picture*: 3 in.



1 in.



3 in.

- b. Scale factor:  $\frac{3}{4}$



*Actual Drawing Measures: 4 in.*

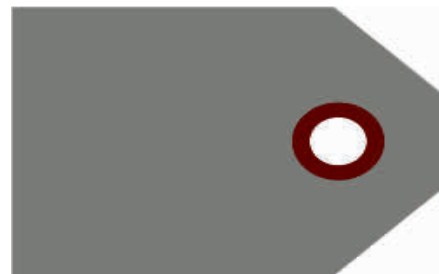

*Scale Drawing Measures: 3 in.*

6. Hayden likes building radio-controlled sailboats with her father. One of the sails, shaped like a right triangle, has side lengths measuring 6 inches, 8 inches, and 10 inches. To log her activity, Hayden creates and collects drawings of all the boats she and her father built together. Using the scale factor of  $\frac{1}{4}$ , create a scale drawing of the sail.

*A triangle with sides 1.5 inches, 2 inches, and 2.5 inches is drawn.*

*Scaffolding:*

Extension: Students can enlarge an image they want to draw or paint by drawing a grid using a ruler over their reference picture and drawing a grid of equal ratio on their work surface. Direct students to focus on one square at a time until the image is complete. Have students compute the scale factor for the drawing.



## Lesson 18: Computing Actual Lengths from a Scale Drawing

### Student Outcomes

- Given a scale drawing, students compute the lengths in the actual picture using the scale. Students identify the scale factor in order to make intuitive comparisons of size and then devise a strategy for efficiently finding actual lengths using the scale.

### Classwork

#### Example 1 (14 minutes): Basketball at Recess?

The first example has students building upon the previous lesson by applying the scale factor to find missing dimensions. This leads into a discussion of whether this method is the most efficient and whether they could find another approach that would be simpler, as demonstrated in Example 2. Guide students to record responses and additional work in their student materials.

#### Scaffolding:

A reduction has a scale factor less than 1, and an enlargement has a scale factor greater than 1.

- How can we use the scale factor to determine the actual measurements?
  - Divide each drawing length by the scale factor to find the actual measurement.

See table below.

- How can we use the scale factor to write an equation relating the scale drawing lengths to the actual lengths?
  - The scale factor is the constant of proportionality or the  $k$  in the equation  $y = kx$  or  $x = \frac{y}{k}$  or even  $= \frac{y}{x}$ . It is the ratio of drawing length to actual length.

#### Example 1: Basketball at Recess?

Vincent proposes an idea to the Student Government to install a basketball hoop along with a court marked with all the shooting lines and boundary lines at his school for students to use at recess. He presents a plan to install a half-court design as shown below. After checking with the school administration, he is told it will be approved if it fits on the empty lot that measures 25 feet by 75 feet on the school property. Will the lot be big enough for the court he planned? Explain.

Scale Drawing: 1 inch on the drawing corresponds to 15 feet of actual length.

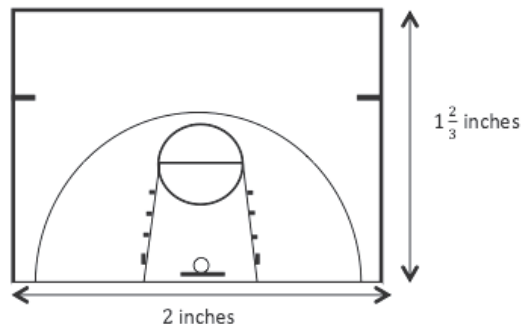

Scale Drawing Lengths	1 in.	2 in.	$1\frac{2}{3}$ in.
Actual Court Lengths	15 ft.	30 ft.	25 ft.

**Scale Factor:** 1 inch corresponds to  $(15 \cdot 12)$  inches, or 180 inches, so the scale factor is 180. Let  $k = 180$ ,  $x$  represent the scale drawing lengths in inches, and  $y$  represent the actual court lengths in inches. The  $y$ -values must be converted from feet to inches.

To find actual length:

$$y = 180x$$

$$y = 180(2)$$

$$y = 360 \text{ inches, or } 30 \text{ feet}$$

To find actual width:

$$y = 180x$$

$$y = 180\left(1\frac{2}{3}\right)$$

$$y = \frac{180}{1} \cdot \frac{5}{3}$$

$$y = 300 \text{ inches, or } 25 \text{ feet}$$

The actual court measures 25 feet by 30 feet. Yes, the lot is big enough for the court Vincent planned. The court will take up the entire width of the lot.

### Example 2 (5 minutes)

Guide the whole class through the completion of the examples below while encouraging student participation through questioning. Students should record the information in their student materials.

Hold a discussion with students regarding the use of the word *scale*.

- Where have you seen this term used?
  - Bottom of a map, blueprint, etc.
- The word scale refers to a type of ratio. 1 cm represents 20 m is an example of a ratio relationship, and the ratio 1:20 is sometimes called a scale ratio or a scale. Why isn't this called the scale factor?
  - The scale factor in a scaled drawing is always a scalar between distances measured in the same units.
- Do we always need to use the scale factor in order to find actual measurements from a scale drawing, or could we just use the given scale ratio (or scale)? (See below.)
- Take a few minutes to try to find the actual length of the garden. Give your answer in meters. Be prepared to explain how you found your answer.

Allow students to share approaches with the class. Students could calculate the scale factor and follow the steps from Example 1, or they may realize that it is not necessary to find the scale factor. They may apply the scale ratio and work the problem using the ratio 1:20, perhaps setting up the proportional relationship  $y = 20x$ , where  $x$  represents the drawing measurement, and  $y$  represents the actual length.

- So then, what two quantities does the constant of proportionality,  $k$ , relate?
  - The constant of proportionality relates the drawing length to the actual length, when converted to the same units if a scale factor is being used. If just the scale ratio is used, then the quantities do not need to be converted to the same units.
- What method was more efficient? Explain why.
  - If we apply the scale ratio, it requires fewer steps.

- Then why would we consider the scale factor?
  - *The scale factor gives us a sense of the comparison. In this example, the scale factor is 2,000, so the scale drawing lengths are  $\frac{1}{2,000}$  of the actual lengths. It is not always easy to see that comparison when you are basing your calculations on the scale. The scale factor helps us reason through the problem and make sense of our results.*
- Now, go back and find the actual width of the garden using the scale ratio.

Elicit responses from students, including an explanation of how they arrived at their answers. Record results on the board for students to see, and be sure students have recorded correct responses in their student materials.

### Example 2

The diagram shown represents a garden. The scale is 1 centimeter for every 20 meters. Each square in the drawing measures 1 cm by 1 cm. Find the actual length and width of the garden based upon the given drawing.

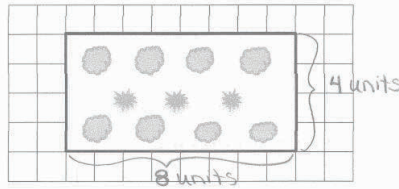

	Scale	Length	Width
Drawing, $x$	1 cm	8 cm	4 cm
Actual, $y$	20 m (or 2,000 cm)	160 m (or 16,000 cm)	80 m (or 8,000 cm)

#### Method 1:

Using the given scale: 1 cm of scale drawing length corresponds to 20 m of actual length.

$$k = 0 \quad \text{Drawing length to actual length}$$

To find the actual length:  $y = 20x$       Where  $x$  represents the the scale drawing measurements in centimeters, and  $y$  represents the actual measurement in meters.

$$y = 20(8) \quad \text{Substitute the scale drawing length in place of } x.$$

$$y = 160$$

The actual length is 80 m.

To find actual width: Divide the actual length by 2 since its drawing width is half the length.

The actual width is 80 m.

#### Method 2:

Use the scale factor: 1 cm of scale drawing length corresponds to 2000 cm of actual length.

$$k = 2000 \quad \text{Drawing length to actual length (in same units)}$$

To find actual length:  $y = 2000x$       Where  $x$  represents the drawing measurement in centimeters, and  $y$  represents the actual measurement in centimeters.

$$y = 2000(8) \quad \text{Substitute the scale drawing length in place of } x.$$

$$y = 16000$$

The actual length is 16,000 cm, or 160 m.

To find actual width:  $y = 2000x$   
 $y = 2000(4)$       *Substitute the scale drawing width in place of  $x$ .*  
 $y = 8000$   
*The actual width is 8,000 cm, or 80 m.*

### Example 3 (10 minutes)

#### Example 3

A graphic designer is creating an advertisement for a tablet. She needs to enlarge the picture given here so that 0.25 inches on the scale picture corresponds to 1 inch on the actual advertisement. What will be the length and width of the tablet on the advertisement?

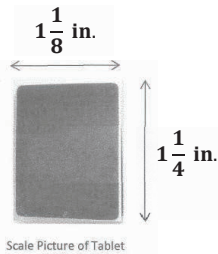

Using a Table:

	Scale	Length	Width
Picture, $x$	0.25 in.	$1\frac{1}{4}$ in.	$1\frac{1}{8}$ in.
Actual Advertisement, $y$	1 in.	5 in.	$4\frac{1}{2}$ in.

Using an Equation:

Find the constant of proportionality,  $k$ :  $k = 4$

$k = 4$  (Scale factor since units of measure are the same; it is an enlargement.)

To find Actual Length:

$y = 4x$       *Where  $x$  represents the picture measurement, and  $y$  represents the actual advertisement measurement.*

$y = 4\left(1\frac{1}{4}\right)$       *Substitute the picture length in place of  $x$ .*

$y = 5$

To find Actual Width:

$y = 4x$

$y = 4\left(1\frac{1}{8}\right)$       *Substitute the picture width in place of  $y$ .*

$y = 4\frac{1}{2}$

*The tablet will be 5 inches by  $4\frac{1}{2}$  inches on the actual advertisement.*

- Is it always necessary to write and solve an equation  $y = kx$  to find actual measurements?
  - *Guide students to conclude that the actual measurement can be found by applying any of the three relationships:  $y = kx$ ,  $x = \frac{y}{k}$  or even  $k = \frac{y}{x}$ . Encourage students to try any of these approaches in the next exercise.*



**Exercise (10 minutes)**

Hold a brief discussion of the problem as a class, and identify how to find the answer. Guide students to identify the following big ideas to address as they solve the problem:

- We need to find the relationship between the lengths in the scale drawing and the corresponding actual lengths.
- Use this relationship to calculate the width of the actual mall entrance.
- Compare this with the width of the panels.

Allow time for students to measure and complete the problem (see the measurement on the diagram below). Encourage students to check with a partner to ensure that their measurements match each other's.

Sample responses shown below include work for two different approaches. Students do not need to apply both and will receive credit for using either method.

*Scaffolding:*

- The map distance of the mall entrance could be noted so that students would not need to measure.
- When determining what unit to use when measuring, look at the given scale.

**Exercise**

Students from the high school are going to perform one of the acts from their upcoming musical at the atrium in the mall. The students want to bring some of the set with them so that the audience can get a better feel for the whole production. The backdrop that they want to bring has panels that measure 10 feet by 10 feet. The students are not sure if they will be able to fit these panels through the entrance of the mall since the panels need to be transported flat (horizontal). They obtain a copy of the mall floor plan, shown below, from the city planning office. Use this diagram to decide if the panels will fit through the entrance.

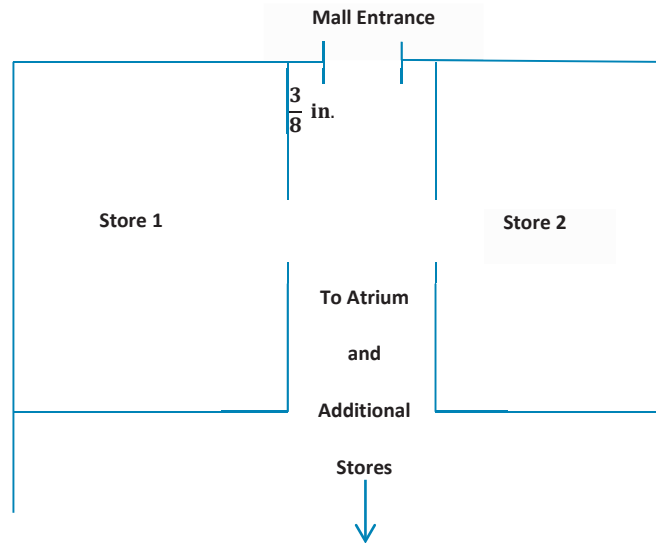
**Scale:**

$\frac{1}{8}$  inch on the drawing represents  $4\frac{1}{2}$  feet of actual length.

Answer the following questions.

- a. Find the actual distance of the mall entrance, and determine whether the set panels will fit.

*Step 1: Relationship between lengths in drawing and lengths in actual*

Scale:  $\frac{4\frac{1}{2} \text{ ft.}}{\frac{1}{8} \text{ in.}}$ , or the value of the ratio  $\frac{36}{1}$  feet to inches

$$\begin{aligned} \text{Scale factor calculations: } & \frac{54}{\frac{1}{8}} \text{ inches to inches} \\ & = \frac{(54) \cdot 8}{\left(\frac{1}{8}\right) \cdot 8} \\ & = 432, \text{ an enlargement} \end{aligned}$$

*Step 2: Find the actual distance of the entrance.*

$$\text{Using the given scale: } \frac{3}{8} \cdot \frac{36}{1} = 13\frac{1}{2}$$

*The actual distance of the entrance is  $13\frac{1}{2}$  feet wide.*

OR

$$\text{Using the scale factor: } \frac{3}{8} \cdot \frac{432}{1} = 162$$

*The actual distance of the entrance is 162 inches, or  $13\frac{1}{2}$  feet, wide.*

*Yes, the set panels, which are 10 ft.  $\times$  10 ft., will fit (lying flat) through the mall entrance.*

- b. What is the scale factor? What does it tell us?

*The scale factor is 432. Each length on the scale drawing is  $\frac{1}{432}$  of the actual length. The actual lengths are 432 times larger than the lengths in the scale drawing.*

### Closing (1 minute)

- What does the scale factor tell us about the relationship between the actual picture and the scale drawing?
  - *It gives us an understanding of how much larger or smaller the scale drawing is compared to the actual picture.*
- How does a scale drawing differ from other drawings?
  - *In a scale drawing, there exists a constant ratio of scale drawing length to actual length, whereas other drawings may not have a constant scale ratio between all corresponding lengths of the drawing and the actual picture or object.*

### Exit Ticket (5 minutes)

Name \_\_\_\_\_

Date \_\_\_\_\_

## Lesson 18: Computing Actual Lengths from a Scale Drawing

### Exit Ticket

A drawing of a surfboard in a catalog shows its length as  $8\frac{4}{9}$  inches. Find the actual length of the surfboard if  $\frac{1}{2}$  inch length on the drawing corresponds to  $\frac{3}{8}$  foot of actual length.

## Exit Ticket Sample Solutions

A drawing of a surfboard in a catalog shows its length as  $8\frac{4}{9}$  inches. Find the actual length of the surfboard if  $\frac{1}{2}$  inch length on the drawing corresponds to  $\frac{3}{8}$  foot of actual length.

	Scale	Equivalent Scale Ratio	Surfboard
Scale Drawing Length, $x$	$\frac{1}{2}$ inch	1 inch	$8\frac{4}{9}$ inches
Actual Length, $y$	$\frac{3}{8}$ foot	$\frac{6}{8}$ ft. or $\frac{3}{4}$ ft.	?

$$\begin{aligned}
 y &= kx \\
 y &= \frac{3}{4}x \\
 &= 8\frac{4}{9} \cdot \frac{3}{4} \\
 &= \frac{76}{9} \cdot \frac{3}{4} \\
 &= \frac{19}{3} \cdot \frac{1}{1}
 \end{aligned}$$

The actual surfboard measures  $6\frac{1}{3}$  feet long.

Note: Students could also use an equation where  $y$  represents the scale drawing, and  $x$  represents the actual measurement, in which case,  $k$  would equal  $\frac{4}{3}$ .

## Problem Set Sample Solutions

1. A toy company is redesigning its packaging for model cars. The graphic design team needs to take the old image shown below and resize it so that  $\frac{1}{2}$  inch on the old packaging represents  $\frac{1}{3}$  inch on the new package. Find the length of the image on the new package.

Car image length on old packaging measures 2 inches.



$\frac{4}{3}$  inches; the scale  $\frac{1}{2}$  to  $\frac{1}{3}$  and the length of the original figure is 2, which is 4 halves, so in the scale drawing the length will be 4 thirds.

2. The city of St. Louis is creating a welcome sign on a billboard for visitors to see as they enter the city. The following picture needs to be enlarged so that  $\frac{1}{2}$  inch represents 7 feet on the actual billboard. Will it fit on a billboard that measures 14 feet in height?



*Yes, the drawing measures 1 inch in height, which corresponds to 14 feet on the actual billboard.*

3. Your mom is repainting your younger brother's room. She is going to project the image shown below onto his wall so that she can paint an enlarged version as a mural. Use a ruler to determine the length of the image of the train. Then determine how long the mural will be if the projector uses a scale where 1 inch of the image represents  $2\frac{1}{2}$  feet on the wall.

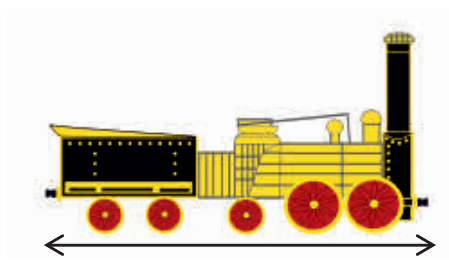

*The scale drawing measures 2 inches, so the image will measure  $2 \times 2.5$ , or 5 feet long, on the wall.*

4. A model of a skyscraper is made so that 1 inch represents 75 feet. What is the height of the actual building if the height of the model is  $18\frac{3}{5}$  inches?  
**1,395 feet**
5. The portrait company that takes little league baseball team photos is offering an option where a portrait of your baseball pose can be enlarged to be used as a wall decal (sticker). Your height in the portrait measures  $3\frac{1}{2}$  inches. If the company uses a scale where 1 inch on the portrait represents 20 inches on the wall decal, find the height on the wall decal. Your actual height is 55 inches. If you stand next to the wall decal, will it be larger or smaller than you?  
*Your height on the wall decal is 70 inches. The wall decal will be larger than your actual height (when you stand next to it).*
6. The sponsor of a 5K run/walk for charity wishes to create a stamp of its billboard to commemorate the event. If the sponsor uses a scale where 1 inch represents 4 feet, and the billboard is a rectangle with a width of 14 feet and a length of 48 feet, what will be the shape and size of the stamp?  
*The stamp will be a rectangle measuring  $3\frac{1}{2}$  inches by 12 inches.*
7. Danielle is creating a scale drawing of her room. The rectangular room measures  $20\frac{1}{2}$  ft. by 25 ft. If her drawing uses the scale where 1 inch represents 2 feet of the actual room, will her drawing fit on an  $8\frac{1}{2}$  in. by 11 in. piece of paper?  
*No, the drawing would be  $10\frac{1}{4}$  inches by  $12\frac{1}{2}$  inches, which is larger than the piece of paper.*

8. A model of an apartment is shown below where  $\frac{1}{4}$  inch represents 4 feet in the actual apartment. Use a ruler to measure the drawing and find the actual length and width of the bedroom.

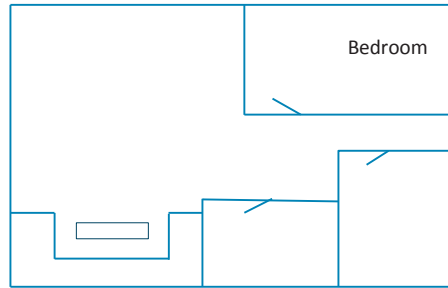

*Ruler measurements:  $1\frac{1}{8}$  inches by  $\frac{9}{16}$  inches.*

*The actual length would be 18 feet, and the actual width would be 9 feet.*



## Lesson 19: Computing Actual Areas from a Scale Drawing

### Student Outcomes

- Students identify the scale factor.
- Given a scale drawing, students compute the area in the actual picture.

### Classwork

#### Examples 1–3 (13 minutes): Exploring Area Relationships

In this series of examples, students identify the scale factor. Students can find the areas of the two figures and calculate the ratio of the areas. As students complete a few more examples, they can be guided to the understanding that the ratio of areas is the square of the scale factor.

#### Examples 1–3: Exploring Area Relationships

Use the diagrams below to find the scale factor and then find the area of each figure.

##### Example 1

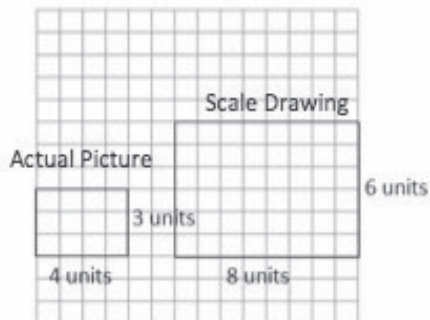

Scale factor: 2

Actual Area = 12 square units

Scale Drawing Area = 48 square units

Value of the Ratio of the Scale Drawing Area to the Actual Area:

$$\frac{48}{12} = 4$$

##### Example 2

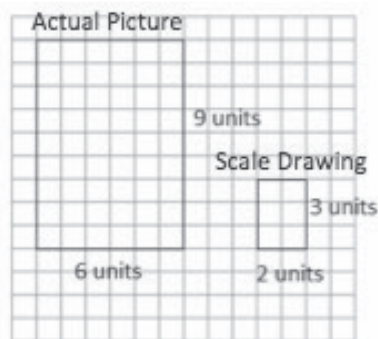

Scale factor:  $\frac{1}{3}$

Actual Area = 54 square units

Scale Drawing Area = 6 square units

Value of the Ratio of the Scale Drawing Area to the Actual Area:

$$\frac{6}{54} = \frac{1}{9}$$

## Example 3

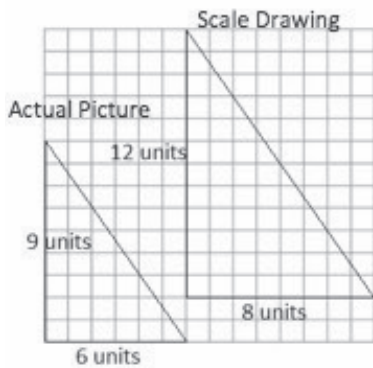

$$\text{Scale factor: } \frac{4}{3}$$

$$\text{Actual Area} = 27 \text{ square units}$$

$$\text{Scale Drawing Area} = 48 \text{ square units}$$

Value of the Ratio of Scale Drawing Area to Actual Area:

$$\frac{48}{27} = \frac{16}{9}$$

Guide students through completing the results statements on the student materials.

**Results:** What do you notice about the ratio of the areas in Examples 1–3? Complete the statements below.

When the scale factor of the sides was 2, then the value of the ratio of the areas was 4.

When the scale factor of the sides was  $\frac{1}{3}$ , then the value of the ratio of the areas was  $\frac{1}{9}$ .

When the scale factor of the sides was  $\frac{4}{3}$ , then the value of the ratio of the areas was  $\frac{16}{9}$ .

Based on these observations, what conclusion can you draw about scale factor and area?

*The ratio of the areas is the scale factor multiplied by itself or squared.*

If the scale factor is  $r$ , then the ratio of the areas is  $r^2$  to 1.

- Why do you think this is? Why do you think it is squared (opposed to cubed or something else)?
  - *When you are comparing areas, you are dealing with two dimensions instead of comparing one linear measurement to another.*
- How might you use this information in working with scale drawings?
  - *In working with scale drawings, you could take the scale factor,  $r$ , and calculate  $r^2$  to determine the relationship between the area of the scale drawing and the area of the actual picture. Given a blueprint for a room, the scale drawing dimensions could be used to find the scale drawing area and could then be applied to determine the actual area. The actual dimensions would not be needed.*
- Suppose a rectangle has an area of 12 square meters. If the rectangle is enlarged by a scale factor of three, what is the area of the enlarged rectangle based on Examples 1–3? Look and think carefully!
  - *If the scale factor is 3, then the ratio of scale drawing area to actual area is  $3^2$  to  $1^2$ , or 9 to 1. So, if its area is 12 square meters before it is enlarged to scale, then the enlarged rectangle will have an area of  $12 \cdot \left(\frac{9}{1}\right)$ , or  $12 \cdot 9$ , resulting in an area of 108 square meters.*



**Example 4 (10 minutes): They Said Yes!**

Complete Example 4 as a class, asking the guiding questions below. Have students use the space in their student materials to record calculations and work.

Give students time to answer the question, possibly choosing to apply what was discovered in Examples 1–3. Allow for discussion of approaches described below and for students to decide what method they prefer.

**Example 4: They Said Yes!**

The Student Government liked your half-court basketball plan. They have asked you to calculate the actual area of the court so that they can estimate the cost of the project.

Based on the drawing below, what will the area of the planned half-court be?

Scale Drawing: 1 inch on the drawing corresponds to 15 feet of actual length.

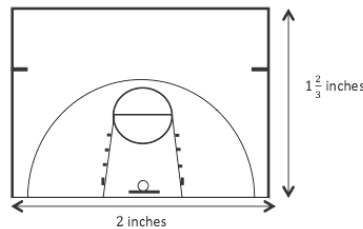

**Method 1:** Use the measurements we found in yesterday's lesson to calculate the area of the half-court.

**Actual area** = 25 feet  $\times$  30 feet = 750 square feet

**Method 2:** Apply the newly discovered Ratio of Area relationship.

Note to teachers: This can be applied to the given scale with no unit conversions (shown on left) or to the scale factor (shown on right). Both options are included here as possible student work and would provide for a rich discussion of why they both work and what method is preferred. See guiding questions below.

**Using Scale:**

The Value of the Ratio of Areas:  $\left(\frac{15}{1}\right)^2 = 225$

Scale Drawing Area = 2 in.  $\times$   $1\frac{2}{3}$  in.  
=  $\frac{10}{3}$  square inches

Let  $x$  = scale drawing area, and let  $y$  = actual area.

$$\begin{aligned} y &= kx \\ y &= 225 \left(\frac{10}{3}\right) \\ y &= \frac{225}{1} \cdot \frac{10}{3} \\ y &= 750 \end{aligned}$$

The actual area using the given scale is 750 square feet.

**Using Scale Factor:**

The Value of the Ratio of Areas  $\left(\frac{180}{1}\right)^2 = 32400$

Scale Drawing Area = 2 in.  $\times$   $1\frac{2}{3}$  in.  
=  $\frac{10}{3}$  square inches

Let  $x$  = scale drawing area, and let  $y$  = actual area.

$$\begin{aligned} y &= kx \\ y &= 32400 \left(\frac{10}{3}\right) \\ y &= \frac{324000}{3} \\ y &= 108000 \end{aligned}$$

The actual area is 108,000 square inches, or  $108000 \text{ square inches} \times \frac{1 \text{ square foot}}{144 \text{ square inches}} = 750 \text{ square feet}$ .

Ask students to share how they found their answer. Use guiding questions to find all three options as noted above.

- What method do you prefer?
- Is there a time you would choose one method over the other?
  - *If we do not already know the actual dimensions, it might be faster to use Method 1 (ratio of areas). If we are re-carpeting a room based upon a scale drawing, we could just take the dimensions from the scale drawing, calculate area, and then apply the ratio of areas to find the actual amount of carpet we need to buy.*

Guide students to complete the follow-up question in their student materials.

Does the actual area you found reflect the results we found from Examples 1–3? Explain how you know.

*Yes, the scale of 1 inch to 15 feet has a scale factor of 180, so the ratio of area should be  $(180)^2$ , or 32,400.*

*The drawing area is  $(2) \left(1\frac{2}{3}\right)$ , or  $\frac{10}{3}$  square inches.*

*The actual area is 25 feet by 30 feet, or 750 square feet, or 108,000 square inches.*

*The value of the ratio of the areas is  $\frac{108,000}{\frac{10}{3}}$ , or  $\frac{324,000}{10}$ , or 32,400.*

It would be more efficient to apply this understanding to the scale, eliminating the need to convert units.

If we use the scale of  $\frac{15}{1}$ , then the ratio of area is  $\frac{225}{1}$ .

The drawing area is  $(2) \left(1\frac{2}{3}\right)$ , or  $\frac{10}{3}$  square inches.

The actual area is 25 feet by 30 feet, or 750 square feet.

The ratio of area is  $\frac{750}{\frac{10}{3}}$ ,  $\frac{2250}{10}$ , or  $\frac{225}{1}$ .

*Scaffolding:*

What do you think the relationship is when considering three dimensions? For example, if the scale factor comparing length on a pair of cubes is  $\frac{1}{3}$ , what is the ratio of volumes for the same cubes?

### Exercises (15 minutes)

Allow time for students to answer independently and then share results.

#### Exercises

1. The triangle depicted by the drawing has an actual area of 36 square units. What is the scale of the drawing? (Note: Each square on the grid has a length of 1 unit.)

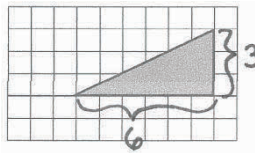

*Scale Drawing Area:*  $\frac{1}{2} \cdot 6 \cdot 3 = 9$  square units. *Ratio of Scale Drawing Area to Actual Area:*  $\frac{9}{36} = r^2$

*Therefore,  $r$  (scale factor) =  $\frac{3}{6}$  since  $\frac{3}{6} \cdot \frac{3}{6} = \frac{9}{36}$ . The scale factor is  $\frac{1}{2}$ . The scale is 1 unit of drawing length represents 2 units of actual length.*

For Exercise 2, allow students time to measure the drawings of the apartments using a ruler and then compare measurements with a partner. Students then continue to complete parts (a)–(f) with a partner. Allow students time to share responses. Sample answers to questions are given below.

**Scaffolding:**  
Guide students to choose measuring units based upon how the scale is stated. For example, since 1 inch represents 12 feet, it would make sense to measure the drawing in inches.

2. Use the scale drawings of two different apartments to answer the questions. Use a ruler to measure.

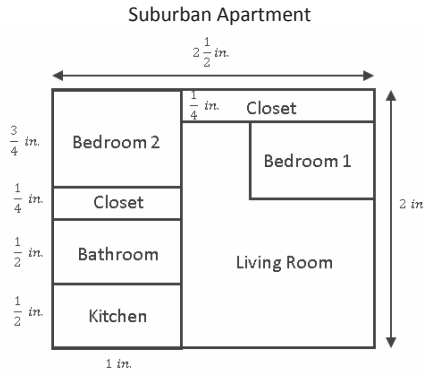

**Scale:** 1 inch on a scale drawing corresponds to 12 feet in the actual apartment.

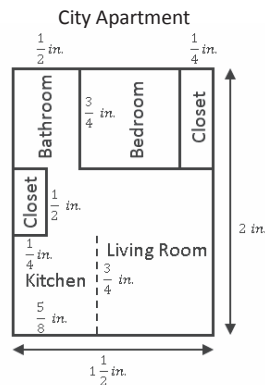

**Scale:** 1 inch on a scale drawing corresponds to 16 feet in the actual apartment.

**Scaffolding:**  
Since the given scale is different for each drawing, it is necessary that students compute the actual areas before comparing the areas in Exercise 2 parts (a)–(c).

a. Find the scale drawing area for both apartments, and then use it to find the actual area of both apartments.

	Suburban	City
Scale Drawing Area (square inches)	$(2\frac{1}{2})(2) = 5$	$(2)(1\frac{1}{2}) = 3$
Actual Area (square feet)	$5(12^2) = 5(144) = 720$	$3(16^2) = 3(256) = 768$

b. Which apartment has closets with more square footage? Justify your thinking.

	Suburban	City
Scale Drawing Area (square inches)	$(1 \cdot \frac{1}{4}) + (1 \cdot \frac{1}{2} \cdot \frac{1}{4}) = \frac{1}{4} + \frac{3}{8} = \frac{5}{8}$	$(\frac{1}{4} \cdot \frac{3}{4}) + (\frac{1}{2} \cdot \frac{1}{4}) = \frac{3}{16} + \frac{1}{8} = \frac{5}{16}$
Actual Area (square feet)	$(\frac{5}{8})(144) = 90$	$(\frac{5}{16})(256) = 80$

The suburban apartment has greater square footage in the closet floors.

- c. Which apartment has the largest bathroom? Justify your thinking.

	Suburban	City
Scale Drawing Area (square inches)	$\left(1 \cdot \frac{1}{2}\right) = \frac{1}{2}$	$\left(\frac{3}{4} \cdot \frac{1}{2}\right) = \frac{3}{8}$
Actual Area (square feet)	$\left(\frac{1}{2}\right)(144) = 72$	$\left(\frac{3}{8}\right)(256) = 96$

*The city apartment has the largest bathroom.*

- d. A one-year lease for the suburban apartment costs \$750 per month. A one-year lease for the city apartment costs \$925. Which apartment offers the greater value in terms of the cost per square foot?

*The suburban cost per square foot is  $\frac{750}{720}$ , or approximately \$1.04 per square foot. The city cost per square foot is  $\frac{925}{768}$ , or approximately \$1.20 per square foot. The suburban apartment offers a greater value (cheaper cost per square foot), \$1.04 versus \$1.20.*

### Closing (2 minutes)

- When given a scale drawing, how do we go about finding the area of the actual object?
  - Method 1: Compute each actual length based upon the given scale, and then use the actual dimensions to compute the actual area.
  - Method 2: Compute the area based upon the given scale drawing dimensions, and then use the square of the scale to find actual area.
- Describe a situation where you might need to know the area of an object given a scale drawing or scale model.
  - A time where you might need to purchase materials that are priced per area, something that has a limited amount of floor space to take up, or when comparing two different blueprints

#### Lesson Summary

Given the scale factor,  $r$ , representing the relationship between scale drawing length and actual length, the square of this scale factor,  $r^2$ , represents the relationship between the scale drawing area and the actual area.

For example, if 1 inch on the scale drawing represents 4 inches of actual length, then the scale factor,  $r$ , is  $\frac{1}{4}$ . On this same drawing, 1 square inch of scale drawing area would represent 16 square inches of actual area since  $r^2$  is  $\frac{1}{16}$ .

### Exit Ticket (5 minutes)

Name \_\_\_\_\_

Date \_\_\_\_\_

## Lesson 19: Computing Actual Areas from a Scale Drawing

### Exit Ticket

A 1-inch length in the scale drawing below corresponds to a length of 12 feet in the actual room.

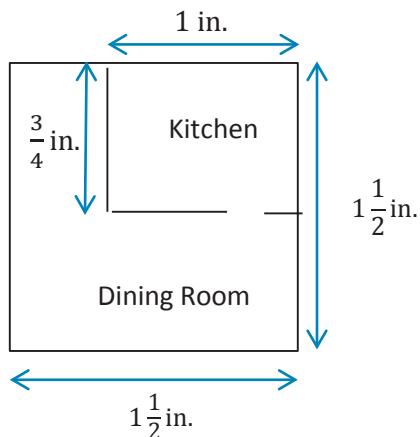

1. Describe how the scale or the scale factor can be used to determine the area of the actual dining room.
2. Find the actual area of the dining room.
3. Can a rectangular table that is 7 ft. long and 4 ft. wide fit into the narrower section of the dining room? Explain your answer.

## Exit Ticket Sample Solutions

A 1-inch length in the scale drawing below corresponds to a length of 12 feet in the actual room.

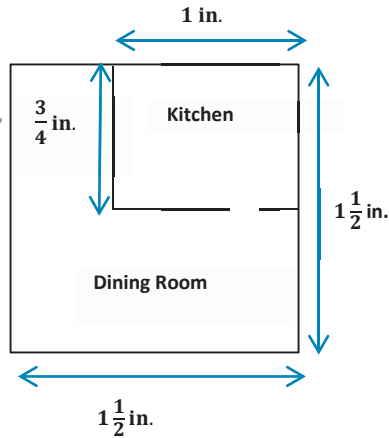
*Scaffolding:*

Extension to Exit Ticket: Ask students to show multiple methods for finding the area of the dining room.

- Describe how the scale or the scale factor can be used to determine the area of the actual dining room.

*The scale drawing will need to be enlarged to get the area or dimensions of the actual dining room. Calculate the area of the scale drawing, and then multiply by the square of the scale (or scale factor) to determine the actual area.*

- Find the actual area of the dining room.

$$\text{Scale drawing area of dining room: } \left(1\frac{1}{2} \text{ in.} \times \frac{3}{4} \text{ in.}\right) + \left(\frac{3}{4} \text{ in.} \times \frac{1}{2} \text{ in.}\right) = \frac{12}{8} \text{ in}^2 \text{ or } 1\frac{1}{2} \text{ in}^2$$

$$\text{Actual area of the dining room: } \frac{12}{8} \text{ ft.} \times 144 \text{ ft.} = 216 \text{ ft}^2$$

*Or similar work completing conversions and using scale factor*

- Can a rectangular table that is 7 ft. long and 4 ft. wide fit into the narrower section of the dining room? Explain your answer.

*The narrower section of the dining room measures  $\frac{3}{4}$  by  $\frac{1}{2}$  in the drawing, or 9 feet by 6 feet in the actual room. Yes, the table will fit; however, it will only allow for 1 additional foot around all sides of the table for movement or chairs.*

## Problem Set Sample Solutions

1. The shaded rectangle shown below is a scale drawing of a rectangle whose area is 288 square feet. What is the scale factor of the drawing? (Note: Each square on the grid has a length of 1 unit.)

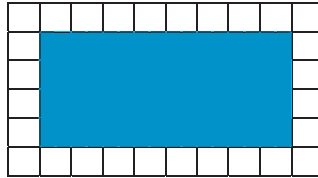

The scale factor is  $\frac{1}{3}$ .

2. A floor plan for a home is shown below where  $\frac{1}{2}$  inch corresponds to 6 feet of the actual home. Bedroom 2 belongs to 13-year-old Kassie, and Bedroom 3 belongs to 9-year-old Alexis. Kassie claims that her younger sister, Alexis, got the bigger bedroom. Is she right? Explain.

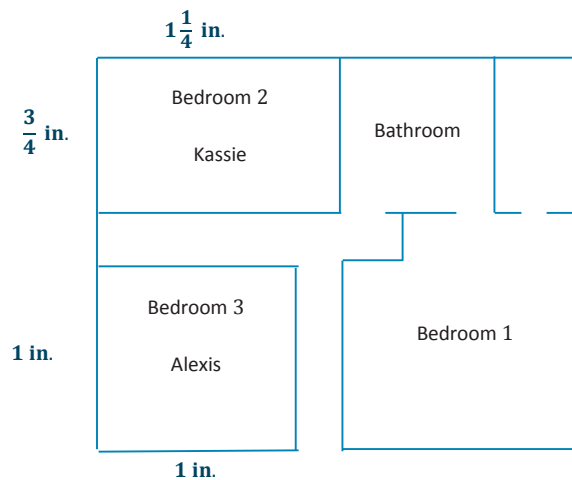

Bedroom 2 (Kassie) has an area of 135 sq. ft., and Bedroom 3 (Alexis) has an area of 144 sq. ft. Therefore, the older sister is correct. Alexis got the bigger bedroom by a difference of 9 square feet.

3. On the mall floor plan,  $\frac{1}{4}$  inch represents 3 feet in the actual store.

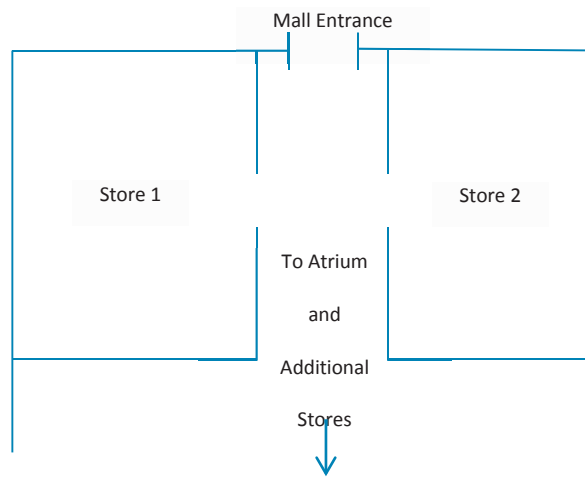

- a. Find the actual area of Store 1 and Store 2.

*The dimensions of Store 1 measure  $1\frac{7}{16}$  inches by  $1\frac{13}{16}$  inches. The actual measurements would be  $17\frac{1}{4}$  feet by  $21\frac{3}{4}$  feet. Store 1 has an area of  $375\frac{3}{16}$  square feet. The dimensions of Store 2 measure  $1\frac{3}{16}$  inches by  $1\frac{13}{16}$  inches. The actual measurements would be  $14\frac{1}{4}$  feet by  $21\frac{3}{4}$  feet. Store 2 has an area of  $309\frac{15}{16}$  square feet.*

- b. In the center of the atrium, there is a large circular water feature that has an area of  $(\frac{9}{64})\pi$  square inches on the drawing. Find the actual area in square feet.

*The water feature has an area of  $(\frac{9}{64})\pi \cdot 144$ , or  $(\frac{81}{4})\pi$  square feet, approximately 63.6 square feet.*

4. The greenhouse club is purchasing seed for the lawn in the school courtyard. The club needs to determine how much to buy. Unfortunately, the club meets after school, and students are unable to find a custodian to unlock the door. Anthony suggests they just use his school map to calculate the area that will need to be covered in seed. He measures the rectangular area on the map and finds the length to be 10 inches and the width to be 6 inches. The map notes the scale of 1 inch representing 7 feet in the actual courtyard. What is the actual area in square feet?

$$70 \times 42 = 2940 \text{ sq. ft.}$$

5. The company installing the new in-ground pool in your backyard has provided you with the scale drawing shown below. If the drawing uses a scale of 1 inch to  $1\frac{3}{4}$  feet, calculate the total amount of two-dimensional space needed for the pool and its surrounding patio.

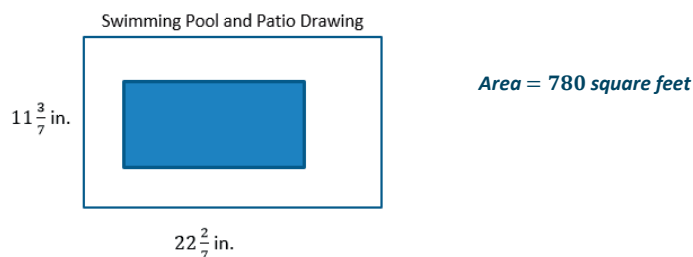





## Lesson 20: An Exercise in Creating a Scale Drawing

### Student Outcomes

- Students create their own scale drawings of the top-view of a furnished room or building.

### Classwork

Preparation (Before Instructional Time): Prepare sheets of grid paper ( $8.5 \times 11$  inches), rulers, and furniture catalogs for student use. Measure the perimeter of the room to give to students beforehand.

Today you will be applying your knowledge from working with scale drawings to create a floor plan for your idea of the dream classroom.

### Exploratory Challenge (37 minutes): Your Dream Classroom

Inform students they will be working in pairs to create their dream classroom. The principal is looking for ideas to create spaces conducive to enjoyable and increased learning. Be as creative as you can be! Didn't you always think there should be nap time? Now, you can create an area for it!

Allow each student to work at his or her own pace. Guidelines are provided in the Student Pages.

#### Exploratory Challenge: Your Dream Classroom

##### Guidelines

**Take measurements:** All students should work with the perimeter of the classroom as well as the doors and windows. Give students the dimensions of the room. Have students use the table provided to record the measurements.

**Create your dream classroom, and use the furniture catalog to pick out your furniture:** Students should discuss what their ideal classroom should look like with their partners and pick out furniture from the catalog. Students should record the actual measurements on the given table.

**Determine the scale and calculate scale drawing lengths and widths:** Each pair of students should determine its own scale. The calculation of the scale drawing lengths, widths, and areas is to be included.

**Scale Drawing:** Using a ruler and referring back to the calculated scale length, students should draw the scale drawing including the doors, windows, and furniture.

##### Scaffolding:

- Have some students measure the perimeter of the classroom for the class beforehand.
- For struggling students: Model the measuring and recording of the perimeter of the classroom.
- Extension: Have students choose flooring and record the costs. Including the furniture, students can calculate the cost of the designed room.

Measurements

	Classroom Perimeter	Windows	Door	Additional Furniture Chairs	Rug	Storage	Bean Bags	Independent Work Tables (× 4)	Board
Actual Length:	40 ft.	5 ft.	3 ft.	1 ft.	$13\frac{1}{3}$ ft.	15 ft.	2 ft.	10 ft.	6 ft.
Width:	30 ft.	/	/	1 ft.	10 ft.	2.5 ft.	2 ft.	3 ft.	/
Scale Drawing Length:	4 in.	$\frac{60}{120}$ $\frac{1}{2}$ in.	$\frac{36}{120}$ $\frac{3}{10}$ in.	$\frac{12}{120}$ $\frac{1}{10}$ in.	$\frac{160}{120}$ $1\frac{1}{3}$ in.	$\frac{180}{120}$ $1\frac{1}{2}$ in.	$\frac{24}{120}$ $\frac{1}{5}$ in.	$\frac{120}{120}$ 1 in.	$\frac{72}{120}$ $\frac{3}{5}$ in.
Width:	3 in.	/	/	$\frac{1}{10}$ in.	$\frac{120}{120}$ 1 in.	$\frac{30}{120}$ $\frac{1}{4}$ in.	$\frac{1}{5}$ in.	$\frac{36}{120}$ $\frac{3}{10}$ in.	/

Scale:  $\frac{1}{120}$

Initial Sketch: Use this space to sketch the classroom perimeter, draw out your ideas, and play with the placement of the furniture.



Scale Drawing: Use a ruler and refer back to the calculated scale length, draw the scale drawing including the doors, windows, and furniture.

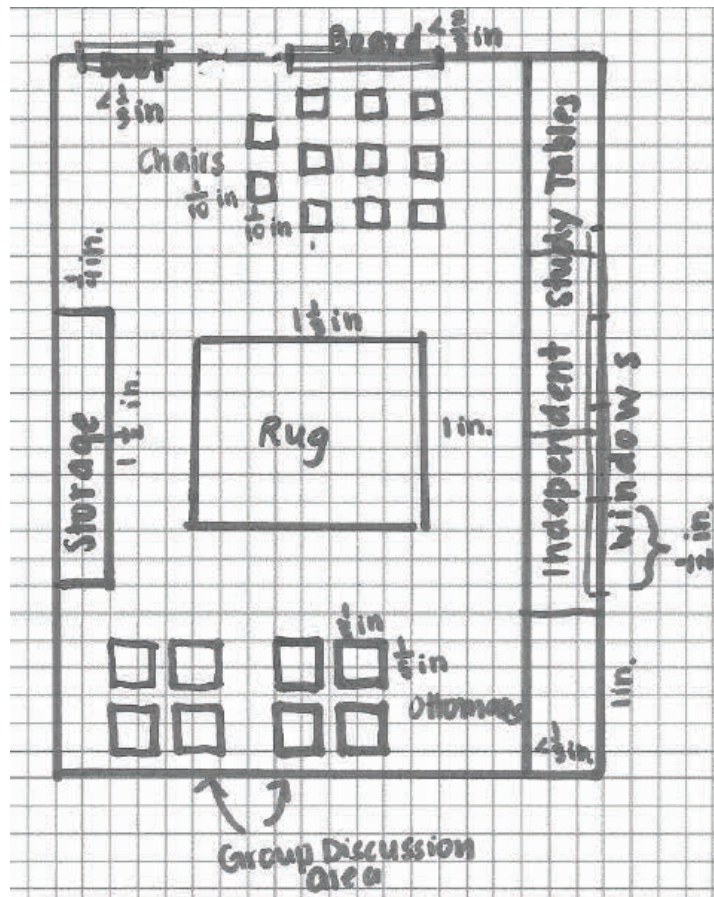

Area

	Classroom	Chairs	Rug	Storage	Bean Bags	Independent Work Tables
Actual Area (ft <sup>2</sup> ):	$40 \times 30$ $= 1200$	$1 \times 1 = 1$	$13\frac{1}{3} \times 10$ $= 133\frac{1}{3}$	$15 \times 2.5$ $= 37.5$	$2 \times 2 = 4$	$10 \times 3 = 30$
Scale Drawing Area (in <sup>2</sup> ):	$4 \times 3 = 12$	$\frac{1}{10} \times \frac{1}{10}$ $= \frac{1}{100}$	$1 \times 1\frac{1}{3}$ $= 1\frac{1}{3}$	$1\frac{1}{2} \times \frac{1}{4}$ $= \frac{3}{2} \times \frac{1}{4} = \frac{3}{8}$	$\frac{1}{5} \times \frac{1}{5} = \frac{1}{25}$	$1 \times \frac{3}{10} = \frac{3}{10}$

**Closing (3 minutes)**

- Why are scale drawings used in construction and design projects?
  - *Scale drawings can be used to rearrange furniture, find appropriate sizes for new items, and reconfigure room size and building size without having to refer back to the actual room or building being worked on.*
- How can we double check our area calculations?
  - *We can check to see if our calculations for area are equal to the number of boxes for each object on the graph paper.*
- What were the biggest challenges you faced when creating your floor plan? How did you overcome these challenges?
  - *It was challenging to select furniture and arrange it in a way that would fit the space.*

**Lesson Summary****Scale Drawing Process:**

1. Measure lengths and widths carefully with a ruler or tape measure. Record measurements in an organized table.
2. Calculate the scale drawing lengths, widths, and areas using what was learned in previous lessons.
3. Calculate the actual areas.
4. Begin by drawing the perimeter, windows, and doorways.
5. Continue to draw the pieces of furniture making note of placement of objects (distance from nearest wall).
6. Check for reasonableness of measurements and calculations.

**Exit Ticket (5 minutes)**

Name \_\_\_\_\_

Date \_\_\_\_\_

## Lesson 20: An Exercise in Creating a Scale Drawing

### Exit Ticket

1. Your sister has just moved into a loft-style apartment in Manhattan and has asked you to be her designer. Indicate the placement of the following objects on the floorplan using the appropriate scale: queen-size bed (60 in. by 80 in.), sofa (36 in. by 64 in.), and dining table (48 in. by 48 in.) In the following scale drawing, 1 cm represents 2 ft. Each square on the grid is  $1 \text{ cm}^2$ .

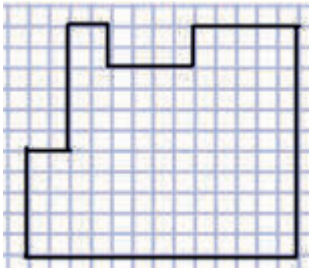

2. Choose one object and explain the procedure to find the scale lengths.

## Exit Ticket Sample Solutions

1. Your sister has just moved into a loft-style apartment in Manhattan and has asked you to be her designer. Indicate the placement of the following objects on the floorplan using the appropriate scale: queen-size bed (60 in. by 80 in.), sofa (36 in. by 64 in.), and dining table (48 in. by 48 in.) In the following scale drawing, 1 cm represents 2 ft. Each square on the grid is  $1 \text{ cm}^2$ .

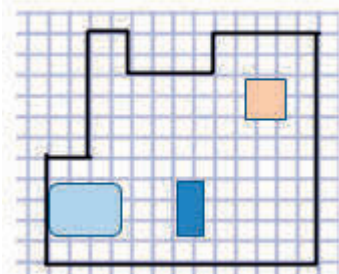

$$\text{Queen Bed: } 60 \div 12 = 5, 5 \div 2 = 2\frac{1}{2}$$

$$80 \div 12 = 6\frac{2}{3}, 6\frac{2}{3} \div 2 = 3\frac{1}{3}$$

The queen bed is  $2\frac{1}{2}$  cm by  $3\frac{1}{3}$  cm in the scale drawing.

$$\text{Sofa: } 36 \div 12 = 3, 3 \div 2 = 1\frac{1}{2}$$

$$64 \div 12 = 5\frac{1}{3}, 5\frac{1}{3} \div 2 = 2\frac{2}{3}$$

The sofa is  $1\frac{1}{2}$  cm by  $2\frac{2}{3}$  cm in the scale drawing.

$$\text{Dining Table: } 48 \div 12 = 4, 4 \div 2 = 2$$

The dining table is 2 cm by 2 cm in the scale drawing.

2. Choose one object and explain the procedure to find the scale lengths.

*Take the actual measurements in inches and divide by 12 inches to express the value in feet. Then divide the actual length in feet by 2 since 2 feet represents 1 centimeter. The resulting quotient is the scale length.*

## Problem Set Sample Solutions

Interior Designer:

You won a spot on a famous interior designing TV show! The designers will work with you and your existing furniture to redesign a room of your choice. Your job is to create a top-view scale drawing of your room and the furniture within it.

- With the scale factor being  $\frac{1}{24}$ , create a scale drawing of your room or other favorite room in your home on a sheet of  $8.5 \times 11$ -inch graph paper.
- Include the perimeter of the room, windows, doorways, and three or more furniture pieces (such as tables, desks, dressers, chairs, bed, sofa, and ottoman).
- Use the table to record lengths and include calculations of areas.
- Make your furniture “moveable” by duplicating your scale drawing and cutting out the furniture.
- Create a “before” and “after” to help you decide how to rearrange your furniture. Take a photo of your “before.”
- What changed in your furniture plans?
- Why do you like the “after” better than the “before”?

*Answers will vary.*

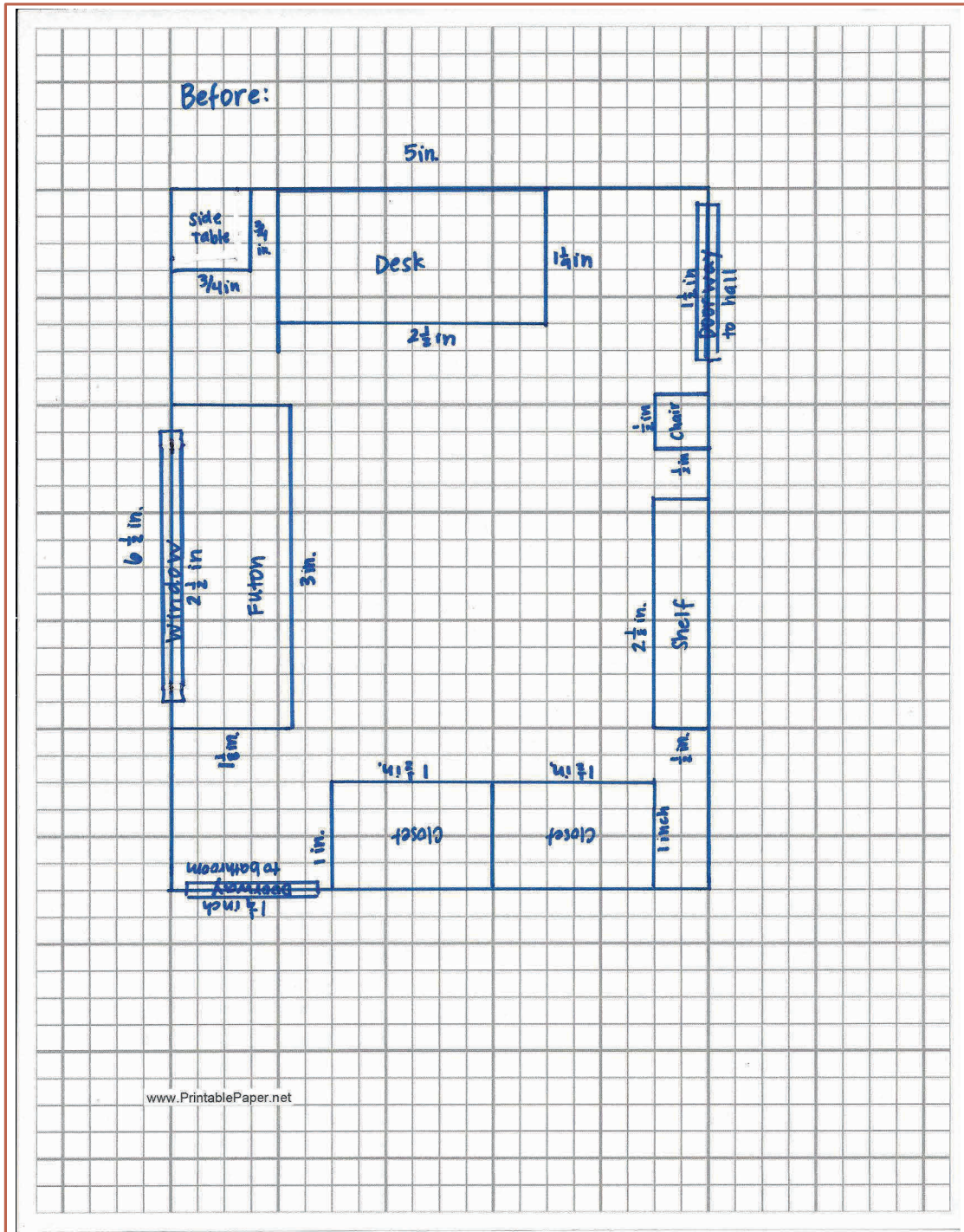

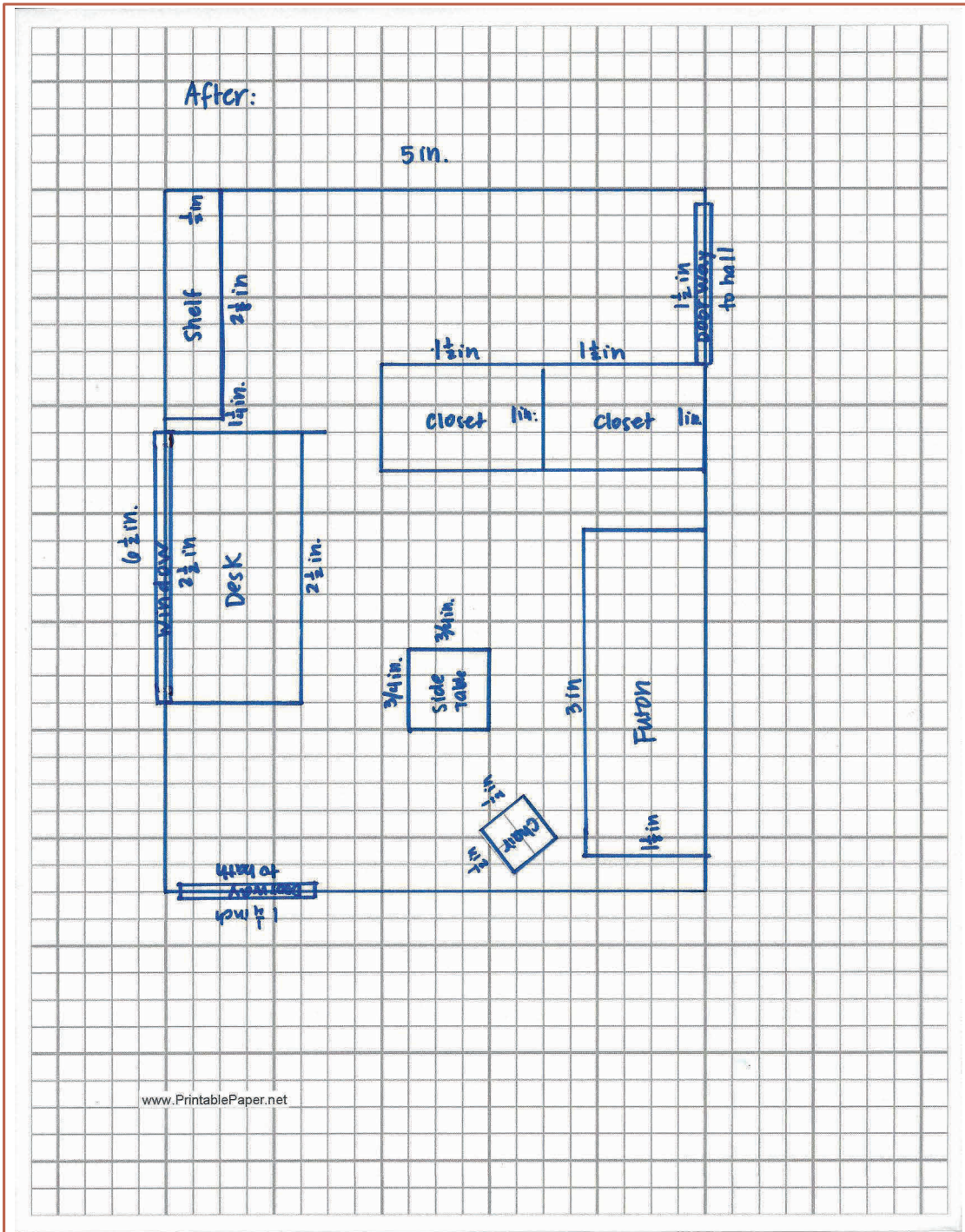



	Entire Room	Windows	Doors	Desk/Tables	Seating	Storage	Bed	Shelf	Side Table
Actual Length:	10 ft.	5 ft.	3 ft.	5 ft.	1 ft.	3 ft.	6 ft.	$5\frac{1}{4}$ ft.	$1\frac{1}{2}$ ft.
Actual Width:	13 ft.	/	/	$2\frac{5}{12}$ ft.	1 ft.	2 ft.	$2\frac{1}{4}$ ft.	1 ft.	$1\frac{1}{2}$ ft.
Scale Drawing Length:	5 in.	$2\frac{1}{2}$ in.	$1\frac{1}{2}$ in.	$2\frac{1}{2}$ in.	$\frac{1}{2}$ in.	$1\frac{1}{2}$ in.	3 in.	$2\frac{5}{8}$ in.	$\frac{3}{4}$ in.
Scale Drawing Width:	$6\frac{1}{2}$ in.	/	/	approx. $1\frac{1}{4}$ in.	$\frac{1}{2}$ in.	1 in.	$1\frac{1}{8}$ in.	$\frac{1}{2}$ in.	$\frac{3}{4}$ in.

	Entire Room Length	Desk/Tables	Seating	Storage	Bed	Shelf	Side Table
Actual Area (ft <sup>2</sup> ):	$10 \times 13 = 130$	$5 \times 2\frac{5}{12} = 5 \times \frac{29}{12} = \frac{145}{12} = 12\frac{1}{12}$	$1 \times 1 = 1$	$3 \times 2 = 6$	$6 \times 2\frac{1}{4} = 6 \times \frac{9}{4} = \frac{27}{2} = 13\frac{1}{2}$	$5\frac{1}{4} \times 1 = 5\frac{1}{4}$	$1\frac{1}{2} \times 1\frac{1}{2} = \frac{3}{2} \times \frac{3}{2} = \frac{9}{4} = 2\frac{1}{4}$
Scale Drawing Area (in <sup>2</sup> ):	$5 \times 6\frac{1}{2} = 5 \times \frac{13}{2} = \frac{65}{2} = 32\frac{1}{2}$	$2\frac{1}{2} \times 1\frac{1}{4} = \frac{5}{2} \times \frac{5}{4} = \frac{25}{8} = 3\frac{1}{8}$	$\frac{1}{2} \times \frac{1}{2} = \frac{1}{4}$	$1\frac{1}{2} \times 1 = 1\frac{1}{2}$	$3 \times 1\frac{1}{8} = 3 \times \frac{9}{8} = \frac{27}{8} = 3\frac{3}{8}$	$2\frac{5}{8} \times \frac{1}{2} = \frac{21}{8} \times \frac{1}{2} = 1\frac{5}{16}$	$\frac{3}{4} \times \frac{3}{4} = \frac{9}{16}$



## Lesson 21: An Exercise in Changing Scales

### Student Outcomes

- Given a scale drawing, students produce a scale drawing of a different scale.
- Students recognize that the scale drawing of a different scale is a scale drawing of the original scale drawing.
- For the scale drawing of a different scale, students compute the scale factor for the original scale drawing.

### Classwork

How does your scale drawing change when a new scale factor is presented?

### Exploratory Challenge (20 minutes): A New Scale Factor

#### Exploratory Challenge: A New Scale Factor

The school plans to publish your work on the dream classroom in the next newsletter. Unfortunately, in order to fit the drawing on the page in the magazine, it must be  $\frac{1}{4}$  its current length. Create a new drawing ( $SD2$ ) in which all of the lengths are  $\frac{1}{4}$  those in the original scale drawing ( $SD1$ ) from Lesson 20.

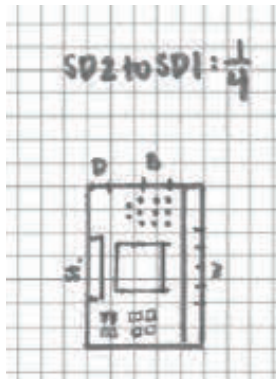

An example is included for students unable to create  $SD1$  at the end of Lesson 20. Pose the following questions:

- Would the new scale create a larger or smaller scale drawing as compared to the original drawing?
  - It would be smaller because  $\frac{1}{4}$  is smaller than one.*
- How would you use the scale factor between  $SD1$  to  $SD2$  to calculate the new scale drawing lengths without having to get the actual measurement first?
  - Take the original scale drawing lengths and multiply them by  $\frac{1}{4}$  to find the new scale lengths.*

Once students have finished creating  $SD2$ , ask students to prove to the architect that  $SD2$  is actually a scale drawing of the original room.

- How can we go about proving that the new scale drawing ( $SD2$ ) is actually a scale drawing of the original room?
  - *The scale lengths of  $SD2$  have to be proportional to the actual lengths. We need to find the constant of proportionality, the scale factor.*
- How do we find the new scale factor?
  - *Divide one of the new scale lengths by its corresponding actual length.*
- If the actual measurement was not known, how could we find it?
  - *Calculate the actual length by using the scale factor on the original drawing. Multiply the scale length of the original drawing by the original scale factor.*

### Exercise (20 minutes)

Write different scale factors on cards from which students can choose:  $\frac{1}{4}$ ,  $\frac{1}{2}$ ,  $\frac{3}{4}$ ,  $1$ ,  $\frac{3}{2}$ ,  $2$ ,  $3$ ,  $4$ . They then create a new scale drawing and calculate the scale factor between their drawing and the original trapezoid in the student material.

After completing parts (a)–(c) independently, have all of the students who were working with enlargements move to the right side of the room and those with reductions to the left. Have students first discuss in smaller groups on their side of the room and then come together as a class to discuss the following:

- Compare your answers to part (a). What can you conclude?
  - *All of the enlargements had a scale factor that was greater than 1. The reductions have a scale factor between zero and 1.*
- What methods did you use to answer part (c)?
  - *The scale factor between  $SD2$  (student-drawn trapezoid) and the original figure can be determined by multiplying the scale factor of  $SD1$  (scale drawing given in the materials) to the original figure by the scale factor of  $SD2$  to  $SD1$ .*

#### Exercise

The picture shows an enlargement or reduction of a scale drawing of a trapezoid.

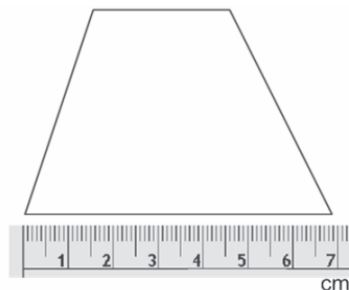

Using the scale factor written on the card you chose, draw your new scale drawing with correctly calculated measurements.

*Answers may vary depending on the card. One sample response could be, 1 cm,  $1\frac{5}{6}$  cm,  $2\frac{1}{3}$  cm,  $1\frac{2}{3}$  cm.*

- a. What is the scale factor between the original scale drawing and the one you drew?

$$\frac{1}{3}$$

- b. The longest base length of the actual trapezoid is 10 cm. What is the scale factor between the original scale drawing and the actual trapezoid?

$$\frac{7}{10}$$

- c. What is the scale factor between the new scale drawing you drew and the actual trapezoid?

$$\frac{2\frac{1}{3}}{10} = \frac{\frac{7}{3}}{10} = \frac{7}{3} \times \frac{1}{10} = \frac{7}{30}$$

#### Changing Scale Factors:

- To produce a scale drawing at a different scale, you must determine the new scale factor. The new scale factor is found by dividing the different (new drawing) scale factor by the original scale factor.
- To find each new length, you can multiply each length in the original scale drawing by this new scale factor.

#### Steps:

- Find each scale factor.
- Divide the new scale factor by the original scale factor.
- Divide the given length by the new scale factor (the quotient from the prior step).

### Closing (5 minutes)

- Why might you want to produce a scale drawing of a different scale?
  - *To produce multiple formats of a drawing (e.g., different-sized papers for a blueprint)*
- How do you produce another scale drawing given the original scale drawing and a different scale?
  - *Take the lengths of the original scale drawing and multiply by the different scale. Measure and draw out the new scale drawing.*
- How can you tell if a new scale drawing is a scale drawing of the original figure?
  - *If the new scale drawing (SD2) is a scale drawing of SD1, then it is a scale drawing of the original figure with a different scale.*
- How can the scale factor of the new drawing to the original figure be determined?
  - *Take the scale length of the new scale drawing and divide it by the actual length of the original figure.*

## Lesson Summary

Variations of Scale Drawings with different scale factors are scale drawings of an original scale drawing.

From a scale drawing at a different scale, the scale factor for the original scale drawing can be computed without information of the actual object, figure, or picture.

- For example, if *scale drawing one* has a scale factor of  $\frac{1}{24}$  and *scale drawing two* has a scale factor of  $\frac{1}{72}$ , then the scale factor relating *scale drawing two* to *scale drawing one* is

$$\frac{1}{72} \text{ to } \frac{1}{24} = \frac{\frac{1}{72}}{\frac{1}{24}} = \frac{1}{72} \cdot \frac{24}{1} = \frac{1}{3}.$$

*Scale drawing two* has lengths that are  $\frac{1}{3}$  the size of the lengths of *scale drawing one*.

## Problem Set Sample Solutions

- Jake reads the following problem: If the original scale factor for a scale drawing of a square swimming pool is  $\frac{1}{90}$ , and the length of the original drawing measured to be 8 inches, what is the length on the new scale drawing if the scale factor of the new scale drawing length to actual length is  $\frac{1}{144}$ ?

He works out the problem:

$$8 \text{ inches} \div \frac{1}{90} = 720 \text{ inches}$$

$$720 \text{ inches} \times \frac{1}{144} = 5 \text{ inches}$$

Is he correct? Explain why or why not.

*Jake is correct. He took the original scale drawing length and divided by the original scale factor to get the actual length, 720 inches. To get the new scale drawing length, he takes the actual length, 720, and multiplies by the new scale factor,  $\frac{1}{144}$ , to get 5 inches.*

- What is the scale factor of the new scale drawing to the original scale drawing (SD2 to SD1)?

$$\frac{\frac{1}{144}}{\frac{1}{90}} = \frac{5}{8}$$

- Using the scale, if the length of the pool measures 10 cm on the new scale drawing:

- Using the scale factor from Problem 1,  $\frac{1}{144}$ , find the actual length of the pool in meters.

14.40 m

- What is the surface area of the floor of the actual pool? Rounded to the nearest tenth.

14.4 m  $\times$  14.4 m

207.36 m<sup>2</sup>  $\approx$  207.4 m<sup>2</sup>

- c. If the pool has a constant depth of 1.5 meters, what is the volume of the pool? Rounded to the nearest tenth.

$$14.4 \text{ m} \times 14.4 \text{ m} \times 1.5 \text{ m}$$

$$311.04 \text{ m}^3 \approx 311.0 \text{ m}^3$$

- d. If 1 cubic meter of water is equal to 264.2 gallons, how much water will the pool contain when completely filled? Rounded to the nearest unit.

$$311.0 \text{ m}^3 \times \frac{264.2 \text{ gallons}}{1 \text{ m}^3}$$

$$82,166.2 \text{ gallons}$$

4. Complete a new scale drawing of your dream room from the Problem Set in Lesson 20 by either reducing by  $\frac{1}{4}$  or enlarging it by 4.

Scale drawings will vary.

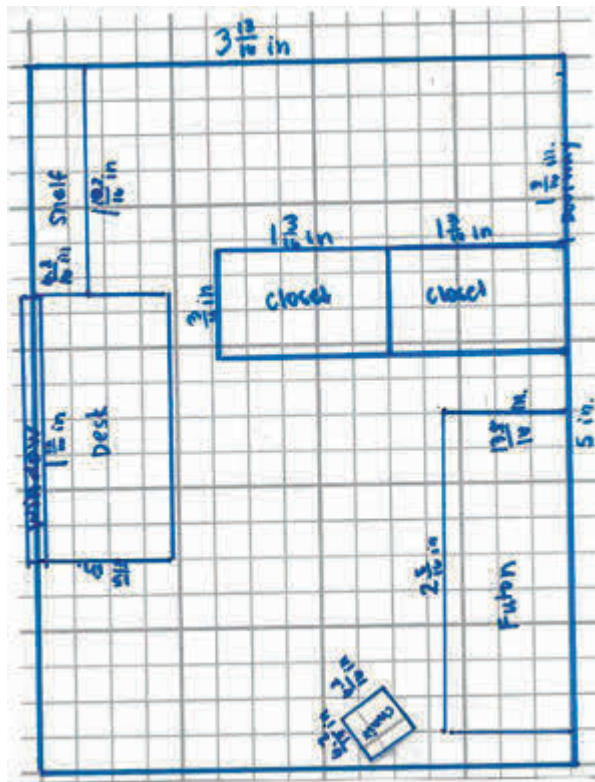

Equivalent Fraction Computations

$\frac{1}{13} \approx \frac{1}{16}$	$\frac{2}{13} \approx \frac{3}{16}$	$\frac{3}{13} \approx \frac{4}{16}$	$\frac{4}{13} \approx \frac{5}{16}$	$\frac{5}{13} \approx \frac{6}{16}$	$\frac{6}{13} \approx \frac{7}{16}$	$\frac{7}{13} \approx \frac{9}{16}$	$\frac{8}{13} \approx \frac{10}{16}$	$\frac{9}{13} \approx \frac{11}{16}$	$\frac{10}{13} \approx \frac{12}{16}$	$\frac{11}{13} \approx \frac{14}{16}$	$\frac{12}{13} \approx \frac{15}{16}$
$16 \times \frac{1}{13}$ = $\frac{16}{13}$ $\approx 1.2$	$16 \times \frac{2}{13}$ = $\frac{32}{13}$ $\approx 2.5$	$16 \times \frac{3}{13}$ = $\frac{48}{13}$ $\approx 3.7$	$16 \times \frac{4}{13}$ = $\frac{64}{13}$ $\approx 4.9$	$16 \times \frac{5}{13}$ = $\frac{80}{13}$ $\approx 6.2$	$16 \times \frac{6}{13}$ = $\frac{96}{13}$ $\approx 7.4$	$16 \times \frac{7}{13}$ = $\frac{112}{13}$ $\approx 8.6$	$16 \times \frac{8}{13}$ = $\frac{128}{13}$ $\approx 9.8$	$16 \times \frac{9}{13}$ = $\frac{144}{13}$ $\approx 11.0$	$16 \times \frac{10}{13}$ = $\frac{160}{13}$ $\approx 12.3$	$16 \times \frac{11}{13}$ = $\frac{176}{13}$ $\approx 13.5$	$16 \times \frac{12}{13}$ = $\frac{192}{13}$ $\approx 14.8$

Conversions (inches)

	Entire Room	Windows	Doors	Desk	Seating	Storage	Bed	Shelf	Side Table
Scale Drawing Length	See above	$2\frac{1}{2} \times \frac{10}{13}$ = $\frac{5}{2} \times \frac{10}{13}$ = $\frac{50}{26}$ = $1\frac{12}{13}$ $\approx 1\frac{15}{16}$	$1\frac{1}{2} \times \frac{10}{13}$ = $\frac{3}{2} \times \frac{10}{13}$ = $\frac{15}{13}$ = $1\frac{2}{13}$ $\approx 1\frac{3}{16}$	Same as window measurement $\approx 1\frac{15}{16}$	$\frac{1}{2} \times \frac{10}{13}$ = $\frac{10}{26}$ = $\frac{5}{13}$ $\approx \frac{6}{16}$	Same as door measurement $\approx 1\frac{3}{16}$	$3 \times \frac{10}{13}$ = $\frac{30}{13}$ = $2\frac{4}{13}$ $\approx 2\frac{5}{16}$	$2\frac{1}{8} \times \frac{10}{13}$ = $\frac{17}{8} \times \frac{10}{13}$ = $\frac{170}{104}$ = $1\frac{66}{104}$ $\approx 1\frac{10}{16}$	$\frac{3}{4} \times \frac{10}{13}$ = $\frac{30}{52}$ = $\frac{15}{26}$ $\approx \frac{9}{16}$
Scale Drawing Width	$5 \times \frac{10}{13}$ = $\frac{50}{13}$ = $3\frac{11}{13}$ $\approx 3\frac{14}{16}$	/	/	$1\frac{1}{4} \times \frac{10}{13}$ = $\frac{5}{4} \times \frac{10}{13}$ = $\frac{50}{52}$ = $\frac{25}{26}$ $\approx \frac{15}{16}$	See above $\approx 6/16$	$1 \times \frac{10}{13}$ = $\frac{10}{13}$ $\approx \frac{12}{16}$	$1\frac{1}{8} \times \frac{10}{13}$ = $\frac{9}{8} \times \frac{10}{13}$ = $\frac{90}{104}$ $\approx 14.16$	See seating measurement $\approx \frac{6}{16}$	See above $\approx \frac{6}{16}$

SD1 Example for students who were unable to create their own from Lesson 20

SCALE FACTOR:  $\frac{1}{120}$

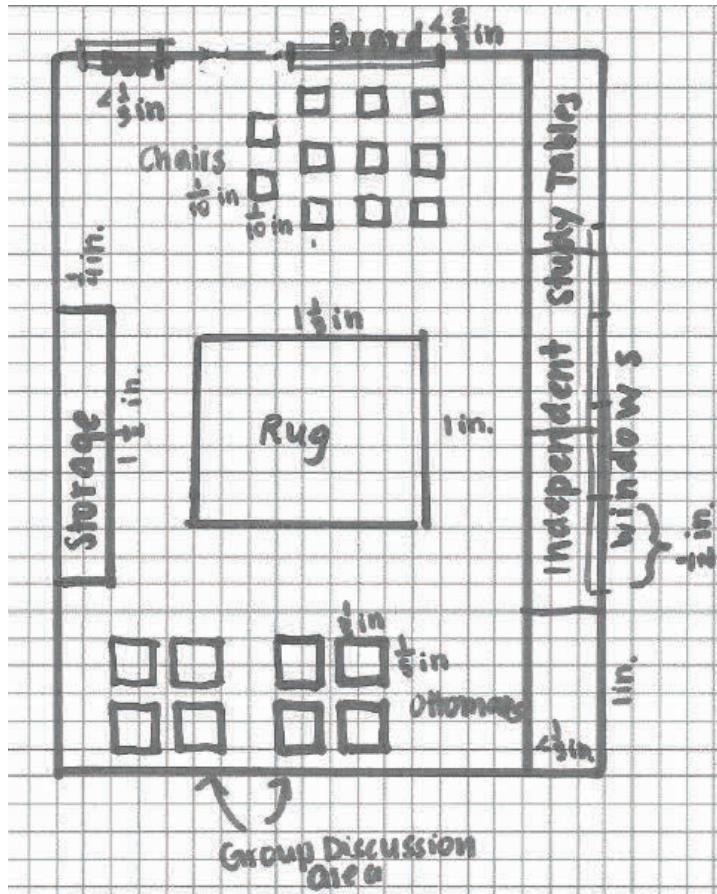





## Lesson 22: An Exercise in Changing Scales

### Student Outcomes

- Given a scale drawing, students produce a scale drawing of a different scale.
- Students recognize that the scale drawing of a different scale is a scale drawing of the original scale drawing.
- For the scale drawing of a different scale, students compute the scale factor for the original scale drawing.

### Classwork

#### Exploratory Challenge (12 minutes): Reflection on Scale Drawings

Ask students to take out the original scale drawing and new scale drawing of their dream rooms they completed as part of the Problem Sets from Lessons 20 and 21. Have students discuss their answers with a partner. Discuss as a class:

- How are the two drawings alike?
- How are the two drawings different?
- What is the scale factor of the new scale drawing to the original scale drawing?

Direct students to fill in the blanks with the two different scale factors. Allow pairs of students to discuss the posed question, “What is the relationship?” for 3 minutes and share responses for 4 minutes. Summarize the Key Idea with students.

Using the new scale drawing of your dream room, list the similarities and differences between this drawing and the original drawing completed for Lesson 20.

#### Similarities

- Same room shape
- Placement of furniture
- Space between furniture
- Drawing of the original room
- Proportional

#### Differences

- One is bigger than the other
- Different scale factors

Original Scale Factor:  $\frac{1}{20}$       New Scale Factor:  $\frac{1}{30}$

What is the relationship between these scale factors?  $\frac{1}{4}$

#### Key Idea:

Two different scale drawings of the same top-view of a room are also scale drawings of each other. In other words, a scale drawing of a different scale can also be considered a scale drawing of the original scale drawing.

**Example 1 (9 minutes): Building a Bench**

Students are given the following information: the scale factor of Taylor’s scale drawing to the actual bench is  $\frac{1}{12}$ , Taylor’s scale drawing, and the measurements of the corresponding lengths (2 in. and 6 in. as shown). Ask the students the following questions:

- What information is important in the diagram?
  - *The scale factor of Taylor’s reproduction.*
- What information can be accessed from the given scale factor?
  - *The actual length of the bench can be computed from the scale length of Taylor’s drawing.*
- What is the process used to find the original scale factor to the actual bench?
  - *Take the length of the new scale drawing, 6 inches, and divide by the scale factor,  $\frac{1}{12}$ , to get the actual length of the bench, 72 inches. The original scale factor,  $\frac{1}{36}$ , can be computed by dividing the original scale length, 2 inches, by the actual length, 72 inches.*
- What is the relationship of Taylor’s drawing to the original drawing?
  - *Taylor’s drawing is 3 times as big as her father’s original drawing. The lengths corresponding to the actual length, which is 72 inches, are 6 inches from Taylor’s drawing and 2 inches from the original drawing.  $\frac{6}{2}$  is 3; therefore, the scale factor is 3.*

**Example 1: Building a Bench**

To surprise her mother, Taylor helped her father build a bench for the front porch. Taylor’s father had the instructions with drawings, but Taylor wanted to have her own copy. She enlarged her copy to make it easier to read. Using the following diagram, fill in the missing information. To complete the first row of the table, write the scale factor of the bench to the bench, the bench to the original diagram, and the bench to Taylor’s diagram. Complete the remaining rows similarly.

The pictures below show the diagram of the bench shown on the original instructions and the diagram of the bench shown on Taylor’s enlarged copy of the instruction.

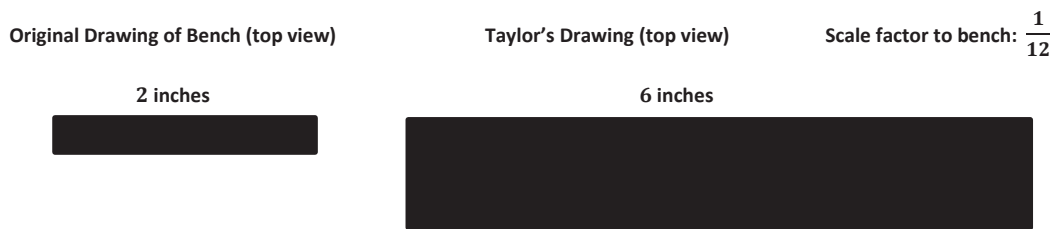

Scale Factors

	Bench	Original Diagram	Taylor’s Diagram
Bench	1	36	12
Original Diagram	$\frac{1}{36}$	1	$\frac{1}{3}$
Taylor’s Diagram	$\frac{1}{12}$	3	1

**Exercise 1 (5 minutes)**

Allow students to work on the problem with partners for 3 minutes. Discuss for 2 minutes:

- How did you find the original scale factor?
  - Divide Carmen's map distance, 4 cm, by the scale factor,  $\frac{1}{563,270}$ , to get the actual distance, 2,253,080 cm. Take the distance from Jackie's map, 26 cm, and divide by the actual distance to get the original scale factor,  $\frac{1}{86,657}$ .
- What are the steps to find the scale of new to original scale drawing?
  - Divide the new scale distance, 4 cm, by the corresponding original scale distance, 26 cm, to get  $\frac{2}{13}$ .
- What is the actual distance in miles?
  - 2,253,080 cm divided by 2.54 cm gives 887,039.37 inches. Divide 887,039.37 by 12 to get 73,919.95 feet. Then, divide 73,919.95 by 5280 to get around 14 miles.
- Would it make more sense to answer in centimeters or miles?
  - Although both are valid units, miles would be a more useful unit to describe the distance driven in a car.

**Exercise 1**

Carmen and Jackie were driving separately to a concert. Jackie printed a map of the directions on a piece of paper before the drive, and Carmen took a picture of Jackie's map on her phone. Carmen's map had a scale factor of  $\frac{1}{563,270}$ . Using the pictures, what is the scale of Carmen's map to Jackie's map? What was the scale factor of Jackie's printed map to the actual distance?

Jackie's Map



$$\text{Scale Factor of SD2 to SD1: } \frac{4}{26} = \frac{2}{13}$$

Carmen's Map

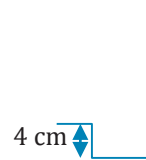

$$\begin{aligned} \text{Scale Factor of SD1 to actual distance: } \frac{\frac{1}{563,270}}{\frac{2}{13}} &= \frac{1}{563,270} \times \frac{13}{2} \\ &= \frac{13}{1,126,540} \end{aligned}$$

**Exercise 2 (9 minutes)**

Allow students to work in pairs to find the solutions.

- What is another way to find the scale factor of the toy set to the actual boxcar?
  - *Take the length of the toy set and divide it by the actual length.*
- What is the purpose of the question in part (c)?
  - *To take notice of the relationships between all the scale factors.*

**Exercise 2**

Ronald received a special toy train set for his birthday. In the picture of the train on the package, the boxcar has the following dimensions: length is  $4\frac{5}{16}$  inches; width is  $1\frac{1}{8}$  inches; height is  $1\frac{5}{8}$  inches. The toy boxcar that Ronald received has dimensions  $l$  is 17.25 inches;  $w$  is 4.5 inches;  $h$  is 6.5 inches. If the actual boxcar is 50 feet long:

- a. Find the scale factor of the picture on the package to the toy set.

$$\frac{4\frac{5}{16}}{17\frac{1}{4}} = 4\frac{5}{16} \div 17\frac{1}{4} = \frac{69}{16} \times \frac{4}{69} = \frac{1}{4}$$

- b. Find the scale factor of the picture on the package to the actual boxcar.

$$\frac{4\frac{5}{16}}{50 \times 12} = \frac{4\frac{5}{16}}{600} = \frac{69}{16} \times \frac{1}{600} = \frac{23}{3200}$$

- c. Use these two scale factors to find the scale factor between the toy set and the actual boxcar.

$$\frac{4\frac{5}{16}}{600} \div \frac{4\frac{5}{16}}{17\frac{1}{4}} = \frac{23}{3200} \div \frac{1}{4} = \frac{23}{3200} \times 4 = \frac{23}{800}$$

- d. What is the width and height of the actual boxcar?

$$w: 4\frac{1}{2} \text{ in.} \div \frac{23}{800} = \frac{9}{2} \text{ in.} \times \frac{800}{23} = 156\frac{12}{23} \text{ in.}$$

$$h: 6\frac{1}{2} \text{ in.} \div \frac{23}{800} = \frac{13}{2} \text{ in.} \times \frac{800}{23} = 226\frac{2}{23} \text{ in.}$$

**Closing (5 minutes)**

- What is the relationship between the scale drawing of a different scale to the original scale drawing?
  - *The scale drawing of a different scale is a scale drawing of the original scale drawing. If the scale factor of one of the drawings is known, the other scale factor can be computed.*
- Describe the process of computing the scale factor for the original scale drawing from the scale drawing at a different scale.
  - *Find corresponding known lengths and compute the actual length from the given scale factor using the new scale drawing. To find the scale factor for the original drawing, write a ratio to compare a drawing length from the original drawing to its corresponding actual length from the second scale drawing.*

**Lesson Summary**

The scale drawing of a different scale is a scale drawing of the original scale drawing.

To find the scale factor for the original drawing, write a ratio to compare a drawing length from the original drawing to its corresponding actual length from the second scale drawing.

Refer to the example below where we compare the drawing length from the Original Scale drawing to its corresponding actual length from the New Scale drawing:

6 inches represents 12 feet or 0.5 feet represents 12 feet

This gives an equivalent ratio of  $\frac{1}{24}$  for the scale factor of the original drawing.

Original Scale drawing:

(unknown SF)



Length is 6 inches on drawing

New Scale drawing (different scale):

1 inch represents 6 feet



Length is 2 inches on drawing, or 12 feet actual length using given scale

**Exit Ticket (5 minute)**

Name \_\_\_\_\_

Date \_\_\_\_\_

## Lesson 22: An Exercise in Changing Scales

### Exit Ticket

The school is building a new wheelchair ramp for one of the remodeled bathrooms. The original drawing was created by the contractor, but the principal drew another scale drawing to see the size of the ramp relative to the walkways surrounding it. Find the missing values on the table.

Original Scale Drawing



12 in.

Principal's Scale Drawing



3 in.

New Scale Factor of *SD2* to the actual ramp:  $\frac{1}{700}$

	Actual Ramp	Original Scale Drawing	Principal's Scale Drawing
Actual Ramp	1		
Original Scale Drawing		1	4
Principal's Scale Drawing			

Exit Ticket Sample Solutions

The school is building a new wheelchair ramp for one of the remodeled bathrooms. The original drawing was created by the contractor, but the principal drew another scale drawing to see the size of the ramp relative to the walkways surrounding it. Find the missing values on the table.

Original Scale Drawing



12 in.

Principal's Scale Drawing



3 in.

New Scale Factor of SD2 to the actual ramp:  $\frac{1}{700}$

Scale Factor Table

	Actual Ramp	Original Scale Drawing	Principal's Scale Drawing
Actual Ramp	1	175	700
Original Scale Drawing	$\frac{1}{175}$	1	4
Principal's Scale Drawing	$\frac{1}{700}$	$\frac{1}{4}$	1

Problem Set Sample Solutions

- For the scale drawing, the actual lengths are labeled onto the scale drawing. Measure the lengths, in centimeters, of the scale drawing with a ruler, and draw a new scale drawing with a scale factor (SD2 to SD1) of  $\frac{1}{2}$ .

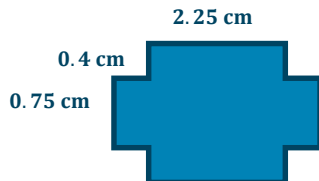
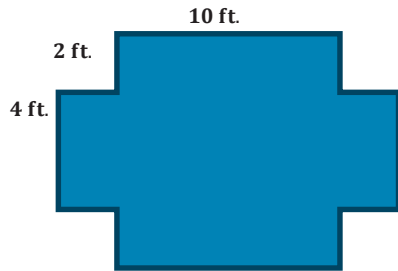

2. Compute the scale factor of the new scale drawing (SD2) to the first scale drawing (SD1) using the information from the given scale drawings.

a. Original Scale Factor:  $\frac{6}{35}$

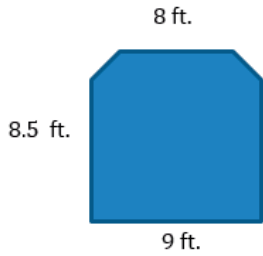

Scale Factor:  $\frac{1}{48}$

New Scale Factor:  $\frac{1}{280}$

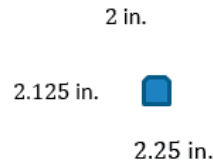

b. Original Scale Factor:  $\frac{1}{12}$

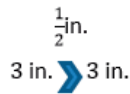

Scale Factor:  $36$

New Scale Factor: 3

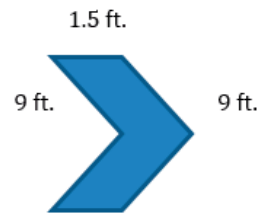

c. Original Scale Factor: 20

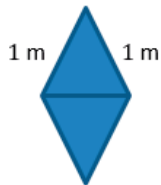

Scale Factor:  $\frac{5}{4}$

New Scale Factor: 25

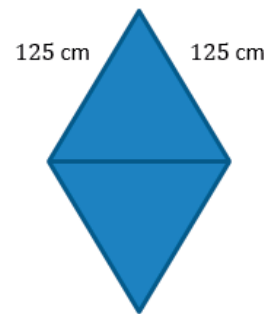





2. Farmers often plant crops in circular areas because one of the most efficient watering systems for crops provides water in a circular area. Passengers in airplanes often notice the distinct circular patterns as they fly over land used for farming. A photographer takes an aerial photo of a field on which a circular crop area has been planted. He prints the photo out and notes that 2 centimeters of length in the photo corresponds to 100 meters in actual length.



- a. What is the scale factor of the actual farm to the photo?
- b. If the dimensions of the entire photo are 25 cm by 20 cm, what are the actual dimensions of the rectangular land area in meters captured by the photo?
- c. If the area of the rectangular photo is  $5 \text{ cm}^2$ , what is the actual area of the rectangular area in square meters?

3. A store is having a sale to celebrate President's Day. Every item in the store is advertised as one-fifth off the original price. If an item is marked with a sale price of \$140, what was its original price? Show your work.
4. Over the break, your uncle and aunt ask you to help them cement the foundation of their newly purchased land and give you a top-view blueprint of the area and proposed layout. A small legend on the corner states that 4 inches of the length corresponds to an actual length of 52 feet.

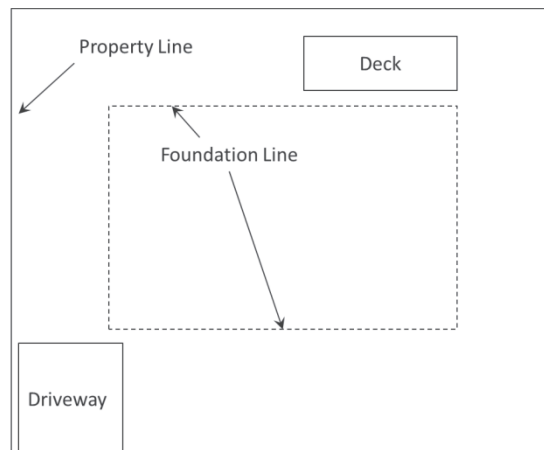

- a. What is the scale factor of the actual foundation to the blueprint?

- b. If the dimensions of the foundation on the blueprint are 11 inches by 13 inches, what are the actual dimensions in feet?
- c. You are asked to go buy bags of dry cement and know that one bag covers 350 square feet. How many bags do you need to buy to finish this project?
- d. After the first 15 minutes of laying down the cement, you have used  $\frac{1}{5}$  of the bag. What is the rate you are laying cement in bags per hour? What is the unit rate?

- e. Write an equation that represents the relationship between the number of bags used,  $y$ , in  $x$  hours.
- f. Your uncle is able to work faster than you. He uses 3 bags for every 2 bags you use. Is the relationship proportional? Explain your reasoning using a graph on a coordinate plane.
- g. What does  $(0,0)$  represent in terms of the situation being described by the graph created in part (f)?
- h. Using a graph, show how many bags you would use if your uncle uses 18 bags.

## A Progression Toward Mastery

Assessment Task Item	STEP 1 Missing or incorrect answer and little evidence of reasoning or application of mathematics to solve the problem.	STEP 2 Missing or incorrect answer but evidence of some reasoning or application of mathematics to solve the problem.	STEP 3 A correct answer with some evidence of reasoning or application of mathematics to solve the problem, <u>OR</u> an incorrect answer with substantial evidence of solid reasoning or application of mathematics to solve the problem.	STEP 4 A correct answer supported by substantial evidence of solid reasoning or application of mathematics to solve the problem.	
1	a	Student answers rate incorrectly and shows no or very limited calculations.	Student sets the problem up incorrectly, resulting in an incorrect rate.	Student sets the problem up correctly but makes minor mistakes in the calculation.	Student correctly sets up the problem and calculates the rate as $\frac{2}{5}$ buckets per hour.
	b	Student is unable to write an equation or writes an equation that is not in the form $y = kx$ or even $x = ky$ for any value $k$ .	Student writes an incorrect equation, such as $y = \frac{5}{2}x$ or $x = \frac{2}{5}y$ , and/or uses an incorrect value of unit rate from part (a) to write the equation in the form $y = kx$ .	Student creates an equation using the constant of proportionality but writes the equation in the form $x = \frac{5}{2}y$ or some other equivalent equation.	Student correctly answers $y = \frac{2}{5}x$ .
	c	Student answer is incorrect. Little or no evidence of reasoning is given.	Student answer is incorrect but shows some evidence of reasoning and usage of an equation for the proportional relationship (though the equation itself may be incorrect).	Student correctly answers 2.5 hours but with minor errors in the use of and calculations based on the equation $y = \frac{2}{5}x$ .	Student correctly answers 2.5 hours with correct work, and the calculations were based on the equation $y = \frac{2}{5}x$ .
2	a	Student is unable to answer, or the answer gives no evidence of understanding the fundamental concept of scale factor as a ratio comparison of corresponding lengths between the image and the actual object.	Student incorrectly calculates the scale factor to be $2 : 100$ , $1 : 150$ , or $\frac{1}{50}$ . The answer expresses scale factor as a comparison of corresponding lengths but does not show evidence of choosing the same measurement unit to make the comparison.	Student correctly calculates the scale factor to be $1 : 5000$ or $\frac{1}{5000}$ but has a minor error in calculations or notation. For example, student writes $\frac{1}{5000}$ cm.	Student correctly calculates the scale factor to be $1 : 5000$ or $\frac{1}{5000}$ with correct calculations and notation.

	<b>b</b>	Student answers incorrectly and gives little or no evidence of understanding scale factor.	Student shows some evidence of reasoning but makes one or more calculation errors, thereby providing an incorrect answer.	Student correctly answers the actual dimensions as $1,250 \text{ m} \times 1,000 \text{ m}$ but does not show work to support the answer.	Student correctly answers the actual dimensions as $1,250 \text{ m} \times 1,000 \text{ m}$ with correct calculations.
	<b>c</b>	Student answers incorrectly and gives little or no evidence of understanding scale factor.	Student shows some evidence of reasoning but makes one or more calculation errors, thereby providing an incorrect answer.	Student correctly answers the actual area as $1,250,000 \text{ m}^2$ but does not show work to support the answer.	Student correctly answers the actual area as $1,250,000 \text{ m}^2$ with correct calculations.
<b>3</b>		Student answer is missing or incorrect. Student shows little or no evidence of reasoning.	Student answers the original price incorrectly but only provides some evidence of reasoning.	Student shows solid evidence of reasoning but makes minor errors in calculations or representations. The answer may or may not be accurate.	Student correctly answers the original price as \$175; student's work demonstrates solid reasoning, and calculations are made without error.
<b>4</b>	<b>a</b>	Student answers incorrectly. No or little evidence of understanding scale factor is shown.	Student incorrectly answers the scale factor to be $\frac{4}{52}$ or another incorrect response. Limited calculations are shown.	Student incorrectly answers the scale factor to be $\frac{1}{13}$ or makes one other minor error in calculations.	Student correctly answers the scale factor to be $\frac{1}{156}$ with correct calculations.
	<b>b</b>	Student answers both of the actual dimensions incorrectly. No or little evidence of understanding scale factor is shown.	Student correctly answers at least one of the dimensions correctly with errors in calculations.	Student correctly answers the actual dimensions as $143 \text{ feet} \times 169 \text{ feet}$ with one or two minor errors in calculations.	Student correctly answers the actual dimensions as $143 \text{ feet} \times 169 \text{ feet}$ with correct calculations.
	<b>c</b>	Student answers incorrectly with no or little evidence of understanding scale factor shown.	Student answers incorrectly but shows some understanding of scale factor in calculations.	Student incorrectly answers 69 bags. OR Student correctly answers 70 bags with one or two minor errors in calculations.	Student correctly answers 70 bags with correct calculations.
	<b>d</b>	Student answers rate incorrectly and shows no or very limited calculations.	Student sets the problem up incorrectly, resulting in an incorrect rate.	Student sets the problem up correctly but makes minor mistakes in the calculation.	Student correctly states the rate as $\frac{4}{5}$ bags per hour and identifies the unit rate as $\frac{4}{5}$ with correct problem setup and calculations.

<b>e</b>	Student is unable to write an equation or writes an equation that is not in the form $y = kx$ or even $x = ky$ for any value $k$ .	Student writes an incorrect equation, such as $y = \frac{5}{4}x$ , or $x = \frac{4}{5}y$ , and/or uses an incorrect value of unit rate from part (d) to write the equation in the form $y = kx$ .	Student creates an equation using the constant of proportionality but writes the equation in the form $x = \frac{5}{4}y$ or some other equivalent equation.	Student correctly answers $y = \frac{4}{5}x$ .
<b>f</b>	Student may or may not answer that the relationship is proportional. Student is unable to provide a complete graph. Student is unable to relate the proportional relationship to the graph.	Student may or may not answer that the relationship is proportional. Student provides a graph with mistakes (i.e., unlabeled axes, incorrect points). Student provides a limited expression of reasoning.	Student correctly answers that the relationship is proportional. Student labels the axes but plots points with minor error. Student explanation is slightly incomplete.	Student correctly answers that the relationship is proportional. Student correctly labels the axes and plots the graph on the coordinate plane. Student reasons that the proportional relationship is due to the graph being straight and going through the origin.
<b>g</b>	Student is unable to describe the situation correctly.	Student is able to explain that the zero is the amount of bags used by either him or the uncle but unable to describe the relationship.	Student describes the relationship correctly but with minor error.	Student correctly explains that $(0,0)$ represents that when he used zero bags, the uncle did not use any bags.
<b>h</b>	Student answers incorrectly and shows no or little understanding of analyzing graphs.	Student answers incorrectly but shows some understanding of analyzing graphs.	Student correctly answers 12 bags but does not identify the point on the graph clearly.	Student correctly answers 12 bags by identifying the point on the graph.



Name \_\_\_\_\_

Date \_\_\_\_\_

1. It is a Saturday morning, and Jeremy has discovered he has a leak coming from the water heater in his attic. Since plumbers charge extra to come out on weekends, Jeremy is planning to use buckets to catch the dripping water. He places a bucket under the drip and steps outside to walk the dog. In half an hour, the bucket is  $\frac{1}{5}$  of the way full.

- a. What is the rate at which the water is leaking per hour?

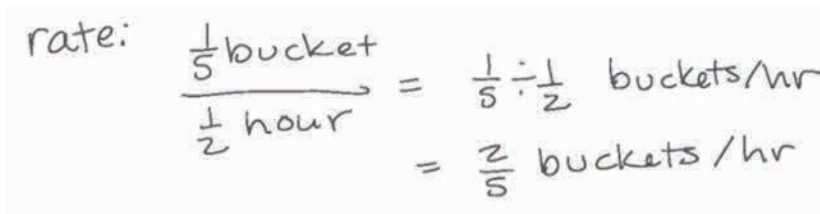

rate:  $\frac{\frac{1}{5} \text{ bucket}}{\frac{1}{2} \text{ hour}} = \frac{1}{5} \div \frac{1}{2} \text{ buckets/hr}$   
 $= \frac{2}{5} \text{ buckets/hr}$

- b. Write an equation that represents the relationship between the number of buckets filled,  $y$ , in  $x$  hours.

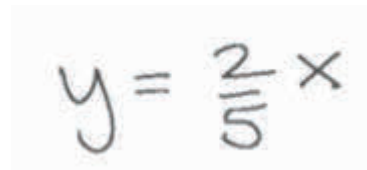
$$y = \frac{2}{5}x$$

- c. What is the longest that Jeremy can be away from the house before the bucket will overflow?

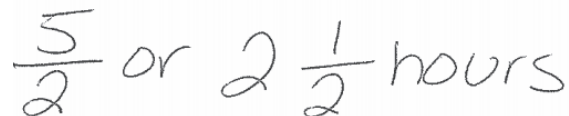
$$\frac{5}{2} \text{ or } 2 \frac{1}{2} \text{ hours}$$

2. Farmers often plant crops in circular areas because one of the most efficient watering systems for crops provides water in a circular area. Passengers in airplanes often notice the distinct circular patterns as they fly over land used for farming. A photographer takes an aerial photo of a field on which a circular crop area has been planted. He prints the photo out and notes that 2 centimeters of length in the photo corresponds to 100 meters in actual length.



- a. What is the scale factor of the actual farm to the photo?

$$\begin{array}{l} 2\text{cm to } 100\text{m} \\ 1\text{cm to } 50\text{m} \\ 1\text{cm to } 5000\text{cm} \end{array} \quad \begin{array}{l} 1:5000 \\ \text{or } \frac{1}{5000} \end{array}$$

- b. If the dimensions of the entire photo are 25 cm by 20 cm, what are the actual dimensions of the rectangular land area in meters captured by the photo?

$$\begin{array}{l} 25\text{cm} \times 50 \frac{\text{m}}{\text{cm}} = 1250 \text{ meters} \\ \text{by } 20\text{cm} \times 50 \frac{\text{m}}{\text{cm}} = 1000 \text{ meters} \\ 1250 \text{ m by } 1000 \text{ m} \end{array}$$

- c. If the area of the rectangular photo is  $5 \text{ cm}^2$ , what is the actual area of the rectangular area in square meters?

Method 1

$$\begin{array}{l} \text{Scale Factor} = \frac{1}{5000} \\ \text{Area of Scale Drawing} = 5\text{cm}^2 = 0.005\text{m}^2 \\ \text{Area of Scale Drawing} = \left(\frac{\text{scale}}{\text{factor}}\right)^2 (\text{actual area}) \\ 0.005 = \left(\frac{1}{5000}\right)^2 (\text{actual area}) \\ 0.005(5000)^2 = \text{actual area} \\ 12,500 = \text{actual area} \\ \text{The actual area is } 12,500\text{m}^2 \end{array}$$

Method 2

use part (b)

$$\begin{array}{l} 1250(1000) \\ 1,250,000 \end{array}$$

The actual area is  $1,250,000\text{m}^2$

3. A store is having a sale to celebrate President's Day. Every item in the store is advertised as one-fifth off the original price. If an item is marked with a sale price of \$140, what was its original price? Show your work.

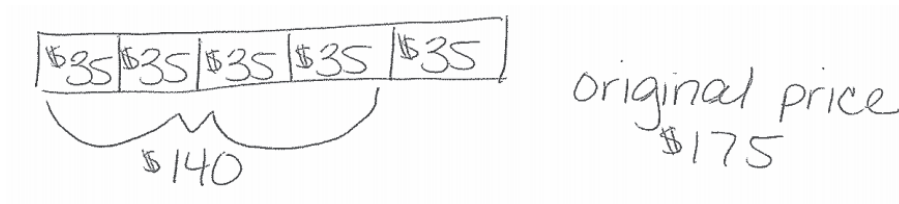

4. Over the break, your uncle and aunt ask you to help them cement the foundation of their newly purchased land and give you a top-view blueprint of the area and proposed layout. A small legend on the corner states that 4 inches of the length corresponds to an actual length of 52 feet.

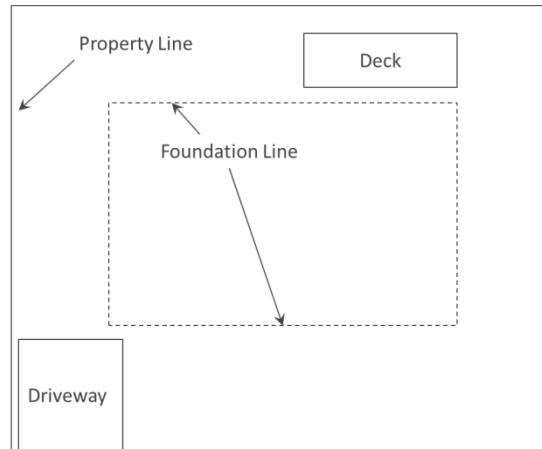

- a. What is the scale factor of the actual foundation to the blueprint?

4 in. to 52 ft.  
1 in. to 13 ft.  
1 in. to 156 in.

$13 \text{ ft.} \times \frac{12 \text{ in.}}{1 \text{ ft.}} = 156 \text{ in.}$

The scale factor is  $\frac{1}{156}$

- b. If the dimensions of the foundation on the blueprint are 11 inches by 13 inches, what are the actual dimensions?

$$11 \text{ in} \times \frac{13 \text{ ft}}{1 \text{ in}} = 143 \text{ ft}$$

$$13 \text{ in} \times \frac{13 \text{ ft}}{1 \text{ in}} = 169 \text{ ft}$$

143 ft by 169 ft

- c. You are asked to go buy bags of dry cement and know that one bag covers 350 square feet. How many bags do you need to buy to finish this project?

Area:

$$\begin{array}{r} 143 \\ \times 169 \\ \hline 1287 \\ 8580 \\ 14300 \\ \hline 24167 \end{array}$$

1 bag	350 ft <sup>2</sup>
10 bags	3500 ft <sup>2</sup>
50 bags	17500
60 bags	21,000 ft <sup>2</sup>
70 bags	24,500

70 bags

- d. After the first 15 minutes of laying down the cement, you have used  $\frac{1}{5}$  of the bag. What is the rate you are laying cement in bags per hour? What is the unit rate?

$$\frac{\frac{1}{5} \text{ bag}}{\frac{1}{4} \text{ hour}} = \frac{1}{5} \cdot \frac{4}{1} \text{ bags/hr} = \frac{4}{5} \frac{\text{bags}}{\text{hr}}$$

unit rate =  $\frac{4}{5}$

- e. Write an equation that represents the relationship between the number of bags,  $y$ , in  $x$  hours.

$$y = \frac{4}{5}x$$

- f. Your uncle is able to work faster than you. He uses 3 bags for every 2 bags you use. Is the relationship proportional? Explain your reasoning using a graph on a coordinate plane.

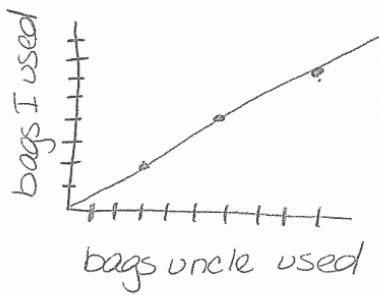

yes, the relationship is proportional, the graph is a straight line through the point  $(0,0)$

- g. What does  $(0,0)$  represent in terms of the situation being described by the graph created in part (f)?

If my uncle uses 0 bags, I also use 0 bags.

- h. Using a graph, show how many bags you would use if your uncle uses 18 bags.

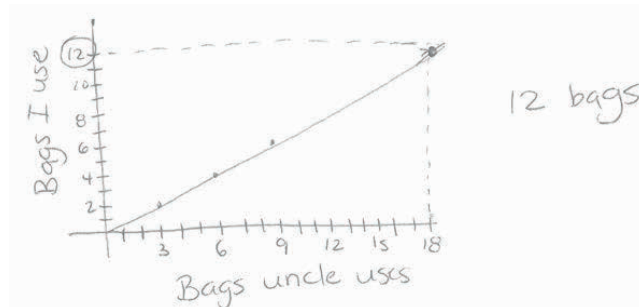

**This page intentionally left blank**

## Credits

Great Minds® has made every effort to obtain permission for the reprinting of all copyrighted material. If any owner of copyrighted material is not acknowledged herein, please contact Great Minds for proper acknowledgment in all future editions and reprints of this module.

- All material from the *Common Core State Standards for Mathematics* © Copyright 2010 National Governors Association Center for Best Practices and Council of Chief State School Officers. All rights reserved.

**This page intentionally left blank**