

Technical Information – Jumpers, Connectors and Memory TKL8255 (8255-xxx) Single-Processor, PICMG 1.3 System Host Board

Layout Diagram – Top

TKL8255 - Layout Diagram (Top)

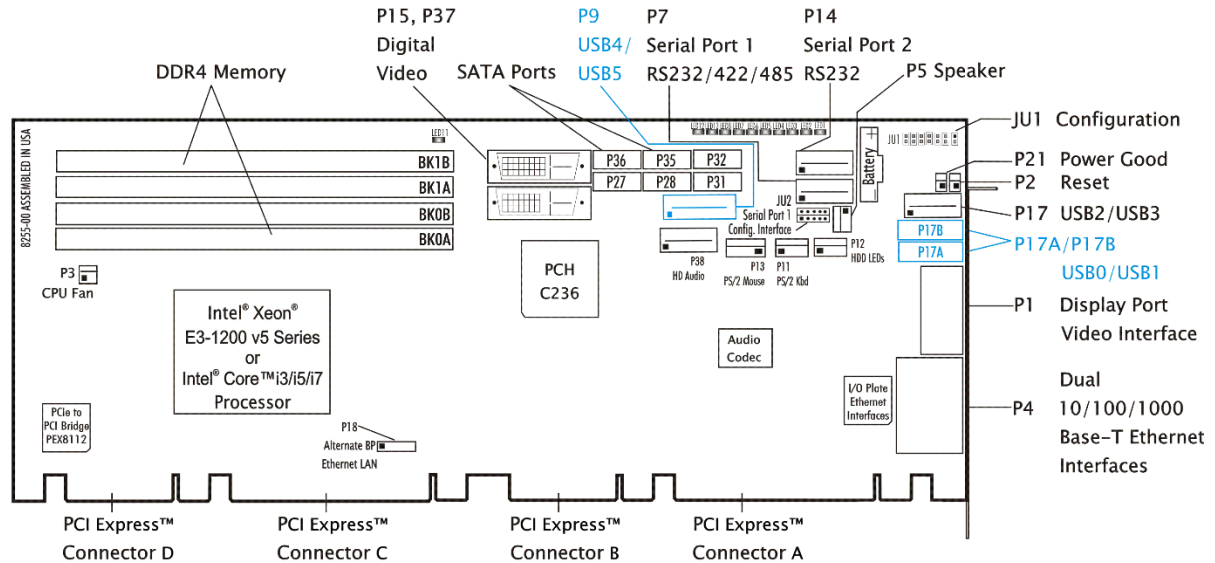

Layout Diagram – Bottom

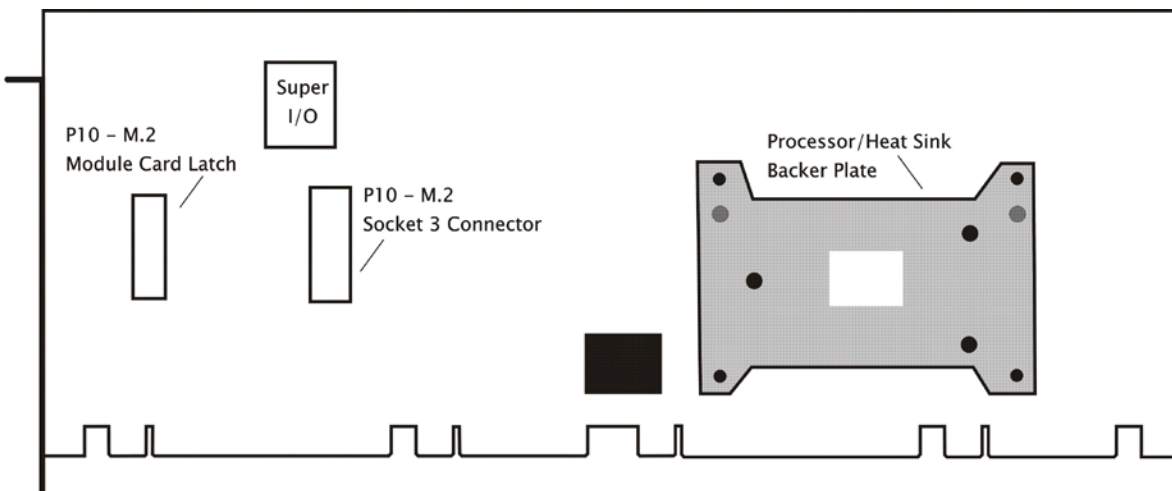

Jumpers

The setup of the configuration jumpers on the SHB is described below. An asterisk (*) indicates the default value of each jumper.

NOTE: Jumper JU1 is a dual-row, 14-pin jumper. Each position controls the operation of a specific SHB implementation

NOTE: For the three-position JU12 jumper, "RIGHT" is toward the I/O bracket side of the board; "LEFT" is toward the header connector P14.

JU1 Pins CMOS Clear
1-2 and Install on pins 1 and 2 to operate *
3-4 Install on pins 3 and 4 to clear.

Note: To clear the CMOS, power down the system and install the JU1 jumper on pins 3 and 4. Wait for at least two seconds, move the jumper back to pins 1 and 2 and turn the power on. Clearing CMOS on the TKL8255 will not result in a checksum error on the following boot. If you want to change a BIOS setting, you must press *DEL* or the *F2* key during POST to enter BIOS setup after clearing CMOS.

JU1 Pins Flash Descriptor Security Override
5-6 No jumper installed on pins 5 and 6 is the normal SHB operating mode.*
Install jumper on pins 5 and 6 at power-on to override SPI-based write policies to unconditionally allow SPI updates.

JU1 Pins Clear Password
7-8 No jumper installed on pins 7 and 8 is the normal SHB operating mode.*
Install jumper on pins 7 and 8 for one power-up cycle to reset the password to the default (null password).

JU1 Pins Management Engine (ME) Recovery
11-12 No jumper installed on pins 11 and 12 is the normal SHB operating mode.*
Install a jumper on pins 11 and 12 at power-on to initiate ME recovery.

JU1 Pins XDP VCCST Override
13-14 No jumper installed on pins 13 and 14 is the normal SHB operating mode.*
Installing a jumper on pins 13 and 14 supports XDP debugging in PCH Sleep States

JU2 Serial Port 1 Interface Configuration
JU2 uses five jumpers to allow serial port one to be configured as either a RS232 or a RS422/RS485 electrical interface. The jumper tables below illustrate the possible interface configurations for serial port one.

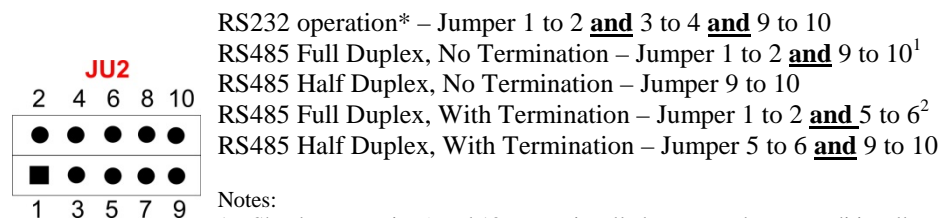

RS232 operation* – Jumper 1 to 2 **and** 3 to 4 **and** 9 to 10
 RS485 Full Duplex, No Termination – Jumper 1 to 2 **and** 9 to 10¹
 RS485 Half Duplex, No Termination – Jumper 9 to 10
 RS485 Full Duplex, With Termination – Jumper 1 to 2 **and** 5 to 6²
 RS485 Half Duplex, With Termination – Jumper 5 to 6 **and** 9 to 10

Notes:
 1 – Shut between pins 9 and 10 can optionally be removed to unconditionally enable the Tx driver
 2 – Shut between pins 9 and 10 can optionally be installed to unconditionally enable the Tx driver

Status LEDs

POST Code LEDs 1 - 8

As the POST (Power On Self-Test) routines are performed during boot-up, test codes are displayed on Port 80 POST Code LEDs 0, 1, 2, 3, 4, 5, 6 and 7. These LEDs are located on the top of the SHB, just above the board's SATA connectors and slightly toward the right. The POST Code LEDs are numbered from right (position 1 = LED1) to left (position 8 = LED8). Refer to the board layout diagram for the exact location of the POST code LEDs.

These POST codes may be helpful as a diagnostic tool. Specific test codes are listed in Appendix A - BIOS Messages section of the TKL8255 Technical Reference Manual. After a normal POST sequence, the LEDs are off (00h) indicating that the SHB's BIOS has passed control over to the operating system loader typically at interrupt INT19h. The chart is from Appendix A and can be used to interpret the LEDs into hexadecimal format during POST.

Upper Nibble (UN)				
Hex. Value	LED8	LED7	LED6	LED5
0	Off	Off	Off	Off
1	Off	Off	Off	On
2	Off	Off	On	Off
3	Off	Off	On	On
4	Off	On	Off	Off
5	Off	On	Off	On
6	Off	On	On	Off
7	Off	On	On	On
8	On	Off	Off	Off
9	On	Off	Off	On
A	On	Off	On	Off
B	On	Off	On	On
C	On	On	Off	Off
D	On	On	Off	On
E	On	On	On	Off
F	On	On	On	On

Lower Nibble (LN)				
Hex. Value	LED4	LED3	LED2	LED1
0	Off	Off	Off	Off
1	Off	Off	Off	On
2	Off	Off	On	Off
3	Off	Off	On	On
4	Off	On	Off	Off
5	Off	On	Off	On
6	Off	On	On	Off
7	Off	On	On	On
8	On	Off	Off	Off
9	On	Off	Off	On
A	On	Off	On	Off
B	On	Off	On	On
C	On	On	Off	Off
D	On	On	Off	On
E	On	On	On	Off
F	On	On	On	On

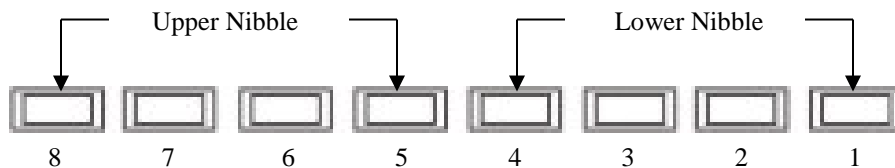

TKL8255 POST Code LEDs

P4A/P4B Ethernet LEDs

The I/O bracket houses the two RJ-45 network connectors for Ethernet LAN1 and LAN2. Each LAN interface connector has two LEDs that indicate activity status and Ethernet connection speed. Listed below are the possible LED conditions and status indications for each LAN connector:

LED/Connector	Description
----------------------	--------------------

Activity LED	This LED identifies the validity of a link on the specific interface. This is the upper LED on the LAN connector (i.e., toward the upper memory sockets).
Off	No valid link exists on this interface.
On (flashing)	Indicates network transmit or receive activity.
On (solid)	Indicates a valid link with no transmit or receive activity.
Speed LED	This multi-color LED identifies the connection speed of the SHB's P4A (LAN2) and P4B (LAN1) Ethernet interfaces. These are the lower LEDs on the dual LAN connector (i.e., toward the edge connectors).
Green	Indicates a valid link at 1000-Mb/s or 1Gb/s
Orange	Indicates a valid link at 100-Mb/s.
Off	Indicates a valid link at 10-Mb/s
RJ-45 Network Connectors	The RJ-45 network connector requires a Connectors category 5 (CAT5) unshielded twisted-pair (UTP) 2-pair cable for a 100-Mb/s network connection or a category 3 (CAT3) or higher UTP 2-pair cable for a 10-Mb/s network connection. A category 5e (CAT5e) or higher UTP 2-pair cable is recommended for a 1000-Mb/s (Gigabit) network connection.

LED11 - Backplane LAN LED

LED11 is located just above the right side of memory DIMM connector BK1B. A flashing LED11 indicates that network transmit and receive activity is occurring on the Ethernet LAN routed to the board's edge connector C / cable connector P18. This LAN provides a network interface for use on a compatible PICMG 1.3 backplane or over a cable.

LED13 – M.2 Activity LED

LED13 is located on the rear of the SHB, near the M.2 slot. A flashing LED13 indicates that I/O activity is occurring on the M.2 bus.

Connectors

NOTE:

A connector's square solder pad located on the bottom side of the PCB indicates pin 1.

P1 –DisplayPort Connector

20-pin digital A/V interface,
Molex #105020-001

PIN	SIGNAL	PIN	SIGNAL
1	TXP0	13	GND
2	GND	14	GND
3	TXN0	15	AUX_P
4	TXP1	16	GND
5	GND	17	AUX_N
6	TXN1	18	HPDET
7	TXP2	19	GND
8	GND	20	VCC3 DP
9	TXN2	21	SGGND1
10	TXP3	22	SGGND2
11	GND	23	SGGND3
12	TXN3	24	SGGND4

P2 - Reset Connector

2 pin single row header, Amp #640456-2

PIN SIGNAL

- 1 Gnd
- 2 Reset In

P3 – CPU Fan Power Connector

4 pin single row MTA, Molex #47053-1000

PIN SIGNAL

- 1 Gnd
- 2 +12V
- 3 Fan Tach
- 4 PWM Control Signal

P4A/P4B – Dual 10/100/1000Base-T Ethernet Connector - LAN1 and LAN2

RJ-45/Dual connector, Pulse #JG0-0024NL

Each individual RJ-45 connector is defined as follows:

PIN	SIGNAL	PIN	SIGNAL
1A	L2_MDI0n	1B	L1_MDI0n
2A	L2_MDI0p	2B	L1_MDI0p
3A	L2_MDI1n	3B	L1_MDI1n
4A	L2_MDI1p	4B	L1_MDI1p
5A	L2_MDI2n	5B	L1_MDI2n
6A	L2_MDI2p	6B	L1_MDI2p
7A	L2_MDI3n	7B	L1_MDI3n
8A	L2_MDI3p	8B	L1_MDI3p
9A	VCC_1.8V	9B	VCC_1.8V
10A	GND_A	10B	GND_b

Notes:

- 1 – LAN ports support standard CAT5 Ethernet cables
- 2 – P4A is LAN2 and P4B is LAN1

P5 - Speaker Port Connector

4 pin single row header, Amp #640456-4

PIN SIGNAL

- 1 Speaker Data
- 2 NC
- 3 Gnd
- 4 +5V

Connectors (continued)

P7 – Serial Port 1 Connector – RS422/RS485 Full Duplex Connections

10 pin dual row header, Amp #5103308-1

PIN	SIGNAL	PIN	SIGNAL
1	Carrier Detect	2	Data Set Ready-I
3	Receive Data-I	4	Request to Send-O
5	Transmit Data-O	6	Clear to Send
7	Data Terminal Ready-O	8	Ring Indicator-I
9	Gnd	10	NC

Note: See JU2 pin-puts listed in the Jumpers & LEDs section on this document to enable serial port 1 signal connections.

P9 – Dual Universal Serial Bus (USB) 3.0 Connector

19 pin dual row header, Lotes ABA-USB-152-K04 (+5V fused with self-resetting fuse)

PIN	USB4 SIGNAL	PIN	USB5 SIGNAL
1	+5V-USB4	11	USBP5P
2	USB3_RX5AN	12	USBP5N
3	USB3_RX5AP	13	GND
4	GND	14	USB3_TX6BP
5	USB3_TX5BN	15	USB3_TX6BN
6	USB3_TX5BP	16	GND
7	GND	17	USB3_RX6AP
8	USBP4N	18	USB_RX6AN
9	USBP4P	19	+5V-USB5
10	ID		

P10 – M.2 M-Key Slot (SHB bottom side)

74 pin, JAE Electronic SM3ZS067U410AMR1000

PIN	SIGNAL	PIN	SIGNAL
1	GND	2	3.3V
3	GND	4	3.3V
5	M2_PE_RXN3	6	NC
7	M2_PE_RXP3	8	NC
9	GND	10	SSD LED#
11	M2_PE_TXN3	12	GND
13	M2_PE_TXP3	14	GND
15	GND	16	GND
17	M2_PE_RXN2	18	GND
19	M2_PE_RXP2	20	NC
21	GND	22	NC
23	M2_PE_TXN2	24	NC
25	M2_PE_TXP2	26	NC
27	GND	28	NC
29	M2_PE_RXN1	30	NC
31	M2_PE_RXP1	32	NC
33	GND	34	NC
35	M2_PE_TXN1	36	NC
37	M2_PE_TXP1	38	M2_DEVSLP
39	GND	40	NC
41	M2_PE_RXP0	42	NC
43	M2_PE_RXN0	44	NC
45	GND	46	NC
47	M2_PE_TXN0	48	NC
49	M2_PE_TXP0	50	IO_RESET#
51	GND	52	M2SSD_CLKREQ
53	M2_CLK100N	54	PCH WAKE#
55	M2_CLK100P	56	NC
57	GND	58	NC
67	NC	68	PCH_SUSCLK
69	M2_PEDET	70	3.3V
71	GND	72	3.3V
73	GND	74	3.3V
75	GND		

Connectors (continued)

P11 – PS/2 Keyboard Header

5 pin single row header, Amp #640456-5

PIN	SIGNAL
1	Kbd Clock
2	Kbd Data
3	NC
4	Kbd Gnd
5	Kbd Power (+5V fused) with self resetting fuse

P12 – Hard Drive LED Connector

4 pin single row header, Amp #640456-4

PIN	SIGNAL
1	LED +
2	LED -
3	LED -
4	LED +

P13 – PS/2 Mouse Header

6 pin single row header, Amp #640456-6

PIN	SIGNAL
1	Ms Data
2	NC
3	Gnd
4	Ms Power (+5V fused) with self resetting fuse
5	Ms Clock
6	NC

P14 – Serial Port 2 Connector – RS232 Connections

10 pin dual row header, Amp #5103308-1

PIN	SIGNAL	PIN	SIGNAL
1	Carrier Detect	2	Data Set Ready-I
3	Receive Data-I	4	Request to Send-O
5	Transmit Data-O	6	Clear to Send
7	Data Terminal Ready-O	8	Ring Indicator-I
9	Gnd	10	NC

Contact Trenton Systems support for specific application information on Serial Port 2 (P14).

P15, P37 – Digital Video Connector (DVI-D)

24-socket digital video connector, Molex #0743205004

PIN	SIGNAL	PIN	SIGNAL	PIN	SIGNAL
1	DVI_TX2N	9	DVI_TX1N	17	DVI_TX0N
2	DVI_TX2P	10	DVI_TX1P	18	DVI_TX0P
3	Gnd	11	Gnd	19	Gnd
4	NC	12	NC	20	NC
5	NC	13	NC	21	NC
6	DVI_SCLK	14	5V	22	Gnd
7	DVI_SDAT	15	Gnd	23	DVI_TXCP
8	NC	16	DVI_HPD	24	DVI_TXCN

Note: Video connector supports standard DVI-D digital video cables

P17A, P17B – Universal Serial Bus (USB) 3.0 Connectors (I/O Bracket)

USB vertical connectors, Molex #48404-0003 (+5V fused with self-resetting fuse)

PIN	P17A SIGNAL	PIN	P17B SIGNAL
1	+5V-USB0	1	+5V-USB1
2	USB0-	2	USB1-
3	USB0+	3	USB1+
4	GND	4	GND
5	USB3_RX1AN	5	USB3_RX2AN
6	USB3_RX1AP	6	USB3_RX2AP
7	GND	7	GND
8	USB3_TX1BN	8	USB3_TX2BN
9	USB3_TX1BP	9	USB3_TX2BP

Note: P17A is USB0 and P17B is USB1

Connectors (continued)

P18 - 10/100/1000Base-T Ethernet Connector – Alternate Backplane LAN Over Cable

8 pin single row connector, Molex #0554500859

PIN	SIGNAL
1	A_MDI2N
2	A_MDI2P
3	A_MDI3N
4	A_MDI3P
5	A_MDI1N
6	A_MDI1P
7	A_MDI0N
8	A_MDI0P

BP LAN Cable Option
You may elect to create your own backplane LAN cable using the mating Molex connector information below. However, Trenton does offer a pre-made alternate backplane LAN cable with the mating Molex connector on one end and an RJ45 connector mounted into an I/O bracket on the other end. The Trenton part number for the alternate backplane LAN cable is: **193500001150-00**.
Note: Using the alternate backplane LAN cable effectively disconnects the LAN routing down to SHB edge connector C.

Note:

The mating Molex connector to use when making this alternative Ethernet cable has a Molex part number of 0513360810.

P38 –HD Audio Connector – Audio Connections

10 pin dual row header, Amp #5103308-1

PIN	SIGNAL	PIN	SIGNAL
1	Line In L	2	Line In R
3	GND	4	GND
5	Mic L	6	Mic R
7	GND	8	Sense_A
9	Line Out L	10	Line Out R

Notes:

1 – For applications requiring external 1/8" audio jacks, use Trenton part # 92-00677700. This board provides Line In, Line Out and Microphone connections from the onboard audio codec to an I/O plate.

P21 – Power Good LED

2 pin single row header, Amp #640456-2

PIN	SIGNAL
1	LED -
2	LED +

P27, P28, P31, P32, P35, P36 – SATA III 600 Ports

7 pin vertical locking connector, Molex #67800-8005

PIN	SIGNAL	PIN	SIGNAL
1	Gnd	5	RX-
2	TX+	6	RX+
3	TX-	7	Gnd
4	Gnd		

Notes:

- 1 – P27 = SATA0 interface, P28 = SATA1 interface,
- P31 = SATA2 interface, P32 = SATA3 interface,
- P35 = SATA4 interface, P36 = SATA5 interface,
- 2 – SATA connectors support standard SATA interface cables
- 3 – All SATA ports support SATA 3.0, SATA 2.0 and SATA 1.0 devices
- 4 – SATA 3.0 = 600MB/s data transfers, SATA 2.0 = 300MB/s data transfers and SATA 1.0 = 150MB/s data transfers

Memory

DDR4-2133 MEMORY

Trenton recommends unbuffered ECC PC4-17000 memory modules for use on the TKL8255. These unbuffered ECC registered (64-bit) DDR4 DIMMs must be PC4-17000 compliant. Unbuffered non-ECC DDR4 DIMMs are also supported on the TKL8255 SHB, but you cannot mix the two different memory types on the same board. The TKL8255 supports DDR4-1866 (PC4-14900) but optimal performance will not be achieved when these modules are utilized.

NOTES:

- To maximize memory interface speed, populate each memory channel with DDR4 DIMMs having the same interface speed. The SHB will support DIMMs with different speeds, but the memory channel interface will operate speed of the slowest DIMM.
- All memory modules must have gold contacts.
- All memory modules must have a 288-pin edge connector
- The SHB supports the following memory module memory latency timings:
 - 16-16-16 for 2133MHz DDR4 DIMMs
- Populate the memory sockets starting with memory channel A and begin by using the DIMM socket closest to the CPU first. Refer to the TKL8255 board layout drawing and populate the memory sockets using the population order illustrated in the chart below:

Population order[#]	CPU1
1	BK0A
2	BK1A
3	BK0B
4	BK1B

[#]Using a balanced memory population approach ensures maximum memory interface performance. A “balanced approach” means using an even number of DIMMs on the TKL8255 SHB whenever possible.

The memory DIMMs on the SHB connect directly to the CPU and at least one memory module must be installed on the board.

[TKL8255 Product Detail](#)