

DUAL-PROCESSOR MicroATX (uATX) EMBEDDED MOTHERBOARD

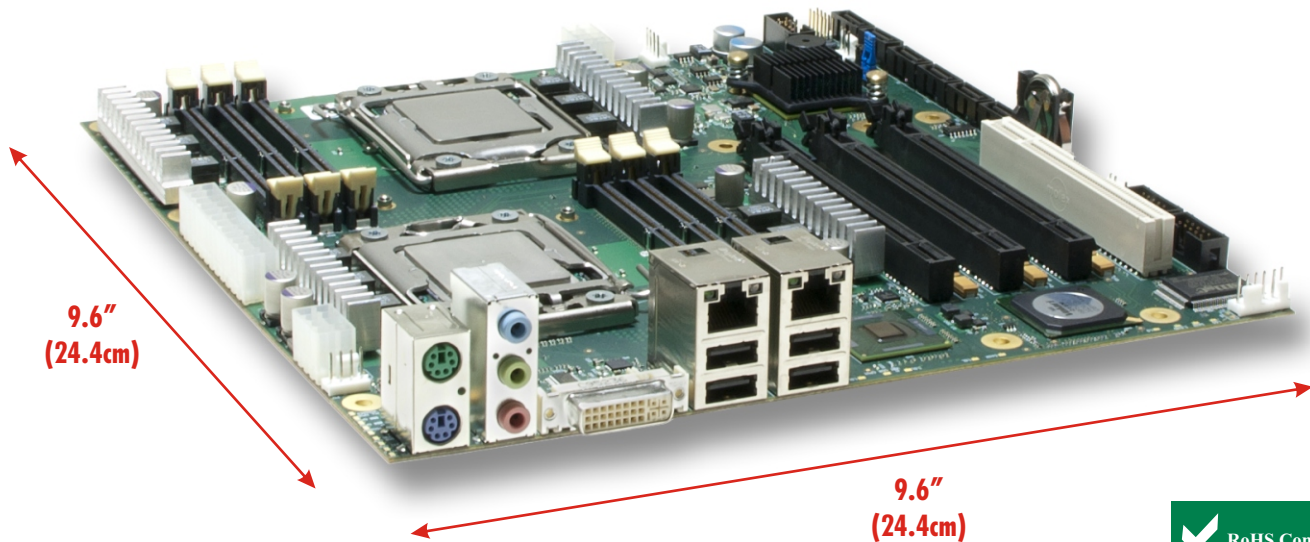

Delivers superior processing performance in an efficient MicroATX (uATX) motherboard form factor using two, quad-core Intel® Xeon® C5500 processors. Trenton's JXM7031 embedded motherboard features:

- System performance boost via advanced CPU micro-architecture
- 9.6" x 9.6" uATX form factor enhances system design flexibility
- x16 PCI Express 2.0 and 1.1 Option Card Support
- Enables compact system designs with multiple CPUs
- Direct DDR3-to-CPU memory performance increases
- 5-year product warranty maximizes system ROI

PROCESSORS & MicroATX FORM FACTOR:

Quad-Core Intel® Xeon® C5500 Processors, 1.73GHz - 2.53GHz*
Processor Package: LGA1366

*Dual-core processor options available

Trenton's JXM7031 packs the enhanced capabilities of two, quad-core CPUs in a small 9.6" x 9.6" uATX motherboard. The processor micro-architecture used in the CPUs feature DDR3 integrated memory controllers and built-in PCIe links to:

- Save power via improved component thermal designs
- Double CPU processing capabilities with the quad-core micro-architecture and Intel® Hyper-Threading (EC5549)
- Enhance system flexibility with Intel® VT-x2 & VT-d2
- Enable compact system designs with long-term availability, technical superiority and improved ROIs

PLATFORM CONTROLLER HUB (PCH):

The Intel® 3420 is a Platform Controller Hub or PCH that saves system power by replacing the typical multi-component chipset with one component. The PCH design approach provides enhanced I/O and additional system interface capabilities.

DUAL ETHERNET INTERFACES - 10/100/1000BASE-T:

The JXM7031 motherboard supports two Gigabit Ethernet ports on the board's I/O panel. The board's Ethernet controller chip is driven with a x4 PCI Express link to ensure fast and reliable network communications.

OPTION CARD SLOTS:

The card slots on the Trenton JXM7031 MicroATX motherboard are configured to support a wide variety of option cards in many different system applications. For example a x16 PCIe mechanical slot is driven with a x16 PCIe 2.0/1.1 electrical link to support high-end video and graphics cards common in machine vision, medical diagnostics and military surveillance applications. Two x8 PCI Express® links drive the remaining two x16 PCIe mechanical slots. All three PCI Express slots support either PCIe 2.0 or 1.1 option cards and automatic link training to support cards with x16, x8, x4 or x1 PCI Express electrical interfaces. The 32-bit/33MHz PCI slot is ideal for supporting system designs with a mix of option card technology.

DDR3-1333 MEMORY INTERFACE:

The DDR3-1333 memory interface is a six-channel interface with three channels on each Intel® Xeon® EC5500 Series Processor. The motherboard uses ECC registered, PC3-8500 or PC3-10600 DDR3 Mini-DIMMs. A maximum memory capacity of 48GB is supported when using 8GB DDR3 Mini-DIMMs and 24GB with 4GB Mini-DIMMs. The JXM7031 can support a maximum memory capacity of 192GB. The peak memory interface bandwidth per channel is 32GB/s when using the PC3-10600 Mini-DIMMs. [Memory population rules](#) are available in the downloads area of the JXM7031 product detail web page.

SERIAL ATA/300 PORTS:

An integrated Serial ATA (SATA) controller in the Intel® 3420 provides six SATA ports with data transfer rates up to 300MB/s. Independent SATA drive operation and RAID drive array configurations are supported on the motherboard.

TPM 1.2 & TRUSTED COMPUTING APPLICATIONS:

The JXM7031 is compliant with version 1.2 of the Trusted Computing Group specification for Trusted Platform Modules via the use of the Atmel® ATC97SC3203 TPM. The card's TPM maximizes the system access security and integrity of any embedded computer design using a Trenton JXM7031 uATX motherboard.

DVI-I VIDEO INTERFACE & AUDIO:

Trenton's JXM7031 motherboard features a Graphics Processing Unit (GPU) driven with a x1 PCIe link from the PCH of the board. The GPU has 8MB of on-board video memory to support pixel resolutions up to 1920 x 1200 (WUXGA) with a 64K color depth. The board's versatile DVI-I video interface connector supports both digital and analog video monitor interfaces. The board may be ordered with a vertical DVI-I connector to support applications where the board is mounted inside a monitor enclosure or in a machine with an internal monitor. Audio ports are available on the motherboard's I/O plate to support a variety of system needs including HD Audio.



TRENTON
Dependable, always.

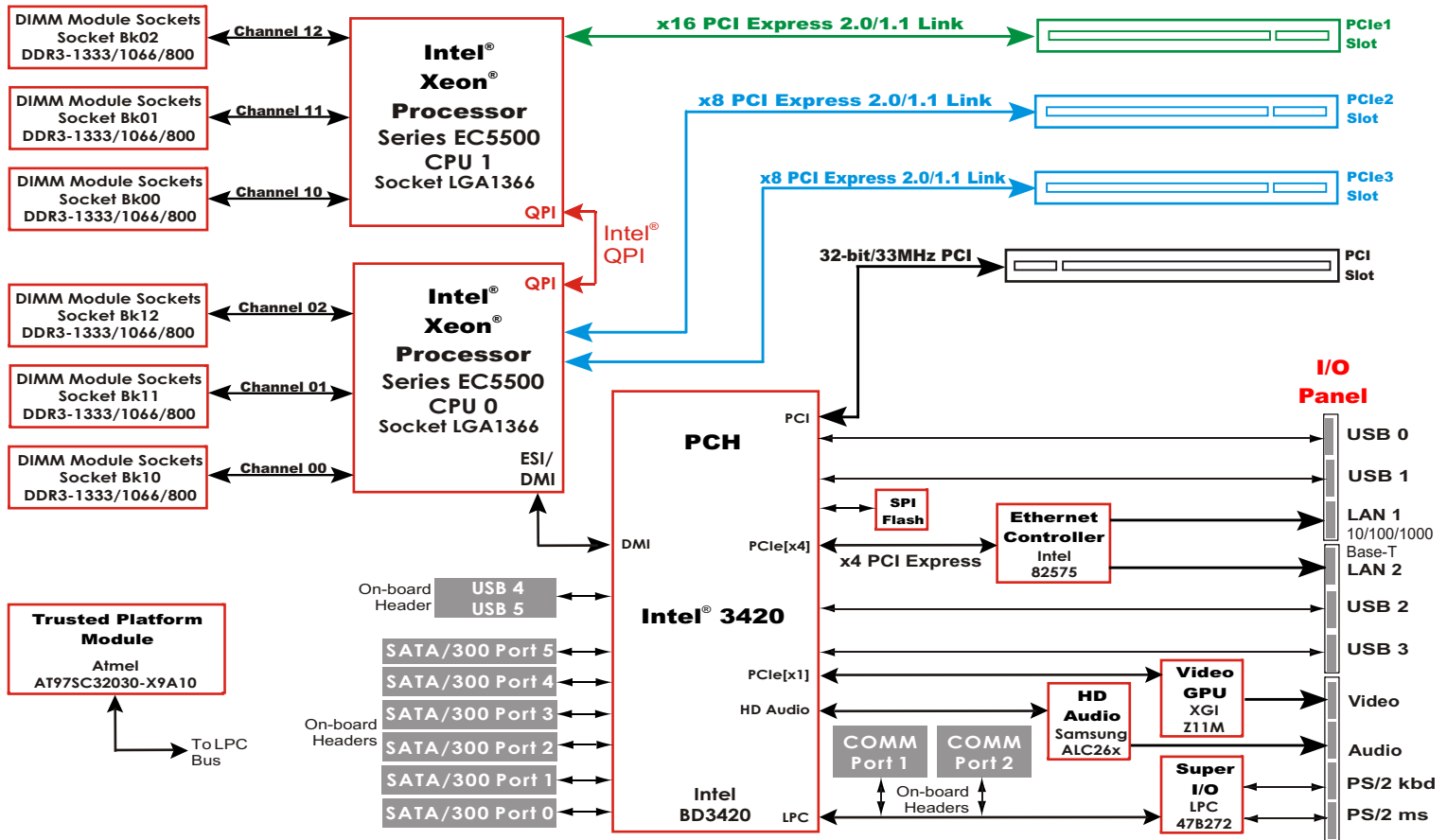

UNIVERSAL SERIAL BUS INTERFACES (USB 2.0):

There are six USB 2.0 interfaces on the JXM7031 motherboard. USB ports 0 through 3 are located on the I/O plate and one on-board header contains USB ports 4 and 5.

RS-232 COMMUNICATION PORTS:

Trenton's JXM7031 motherboard supports two serial COMM parts. The board features two RS-232 serial communication port headers for use in system set-up, system monitoring and data transfer applications.

BIOS (FLASH):

JXM7031 board use Aptio[®] 4.x BIOS from American Megatrends, Inc. (AMI). The JXM7031's BIOS resides in the motherboard's SPI Flash device to simplify field upgrades and BIOS customization.

STANDARDS:

- PCI Express[®] Base Specifications 2.0 and 1.1
- MicroATX Motherboard Specification 1.2
- IEEE P996, Personal Computer Bus Standard

AGENCY APPROVALS:

UL60950, CAN/CSA C22.2 No. 60950-00, EN55022:1998 Class B, EN61000-4-2:1995, EN61000-4-3:1997, EN61000-4-4:1995, EN61000-4-5:1995, EN61000-4-6:1996, EN61000-4-11:1994

APPLICATION CONSIDERATIONS:

Power Requirements:

Typical Values - Static Desktop (Idle) with 6GB of system memory

CPU	Intel [®] No.	+5V	+12V	+3.3V
2.53GHz	EC5549	0.92A	6.75A	2.54A
2.27GHz	EC5539 ^o	1.10A	7.17A	2.63A
2.06GHz	EC5509	0.92A	6.55A	2.44A
2.13GHz	LC5528	0.65A	5.67A	2.59A

Typical Values - 100% Stress State with 6GB of system memory

CPU	Intel [®] No.	+5V	+12V	+3.3V
2.53GHz	EC5549	0.92A	15.35A	2.56A
2.27GHz	EC5539 ^o	1.10A	12.21A	2.63A
2.06GHz	EC5509	0.92A	11.21A	2.44A
2.13GHz	LC5528	0.66A	12.64A	2.71A

D = Dual-core CPU

Note: Power numbers shown for dual-processor model: JXM7031

Temperature/Environment:

Operating Temperature: 0^o to 50^o C.
 Air Flow Requirement: 350LFM continuous airflow
 Storage Temperature: -20^o to 70^o C.
 Humidity: 5% to 90% non-condensing

Mechanical:

The form factor of the JXM7031 complies with the MicroATX Motherboard Specification 1.2 that defines industry standard mounting hole placements and overall board dimensions of 9.6" (24.4cm) x 9.6" (24.4cm). The standard height cooling solution is designed for 2U and greater chassis heights. Contact Trenton if your system design requires a lower profile cooling solution for a 1U chassis design.

ORDERING INFORMATION:

Model No.	CPU Speed	Intel [®] No.*
507031-225-xG	2.53GHz	EC5549
507031-525-xG	2.27GHz	EC5539 ^o
507031-153-xG	2.06GHz	EC5509 ^o
507031-324-xG	2.13GHz	LC5528

(xG = Memory)

* = All CPU options are embedded CPUs, # = CPU options without Hyper-Threading
 NOTE: Model numbers reflect side-mounted CPU cooling fans

The stated processing, memory and communication interface speeds and bandwidths are component maximums; actual system performance may vary.

Intel, Intel Xeon, Intel Virtualization Technology, Intel Hyper-Threading, Intel VT-x2 and Intel VT-d2 are trademarks or registered trademarks of Intel Corporation.

All other product names are trademarks of their respective owners.

Copyright ©2012 by TRENTON Technology Inc. All rights reserved



Dependable, always.